

Heating
Duck Vap Radiant Heating Panels
Vacuum Steam Heating System



ISO 9001 - Cert. n° 0545/2
Unit heaters
Radiant panels
Fan coils
Air handling units
Flues



SABIANA
ENVIRONMENTAL COMFORT

CONTENTS

• Vacuum steam systems	3
• System layout	4
• Advantages of the system	5
- Savings	5
- Flexibility	5
- Reliability	5
- Comfort	6
- Safety	6
• System components:	
Sabiana VAS series steam generators by Comitec	7
- Safety devices	9
• System components: Duck Vap series radiant heating panels	10
- Outline of the heating panel components	10
- Modular widths	12
- Modular lengths	12
- Heat output of the heating panels	13
- Manifolds and fittings	13
- Unit weights	13
• System components:	
Sabiana ASA air venting device by Comitec	14
• System components: control panel	15
• Sizing the installation	16
- Calculating heat loss	16
- Lengths of the heating panels	16
- Choice of model	17
- Steam pipes	18
- Condensation pipes	19
- Selecting the steam generator	19
• Technical tips	20
- Positioning the generator	20
- Steam and condensation lines	21
- Positioning the ASA air venting device	23
- Electrical connections	25
- Gas pipe connections	26

The use of the Sabiana radiant heating panels, enhanced by the VAS vacuum steam generators, brings the recognised advantages of a radiant heating system with reduced installation costs, together with the possibility of installing the generators outside, therefore reducing the need for a boiler room.

The uniqueness of this system lies in their operation under vacuum, which allows the natural expansion of the steam and the return of the condensation by gravity. It is therefore a closed and sealed circuit **in which there is no consumption of steam and no need to top up the water.**

The vacuum system furthermore generates steam at a **maximum temperature of 110°C, which corresponds to a relative pressure of 0.45 bar** (1.45 bar absolute pressure) and as a consequence **the system is not pressurised under normal operating conditions.**

A SABIANA VAS steam generator by COMITEC and the system connected to it make up a sealed circuit with total recovery of the condensation.

As regards to the safety standards, these come under the definition of “Self-producing steam recipients” with an operating pressure of <0.5 bar and **may do not need to be declared to or checked by safety authorities.**

The VAS series generators do not fall within the field of application of EC Directive 97/23 on pressure equipment, as specified in art. 1 and Table 5 of Annex II, being fuel-fired pressure equipment with $P < 0.5$ bar.

The steam generators comply with the requirements described in the “EEC Gas Appliances Directive (90/396)”, (see copy of certification on page 27).

System layout

The system is made up of a boiler **A**, partially filled with water, a steam outlet pipe **B** that leaves the boiler, a condensation collection pipe **C** that returns to the boiler, and a series of radiant heating panels **D** connecting the steam pipe and the condensation pipe.

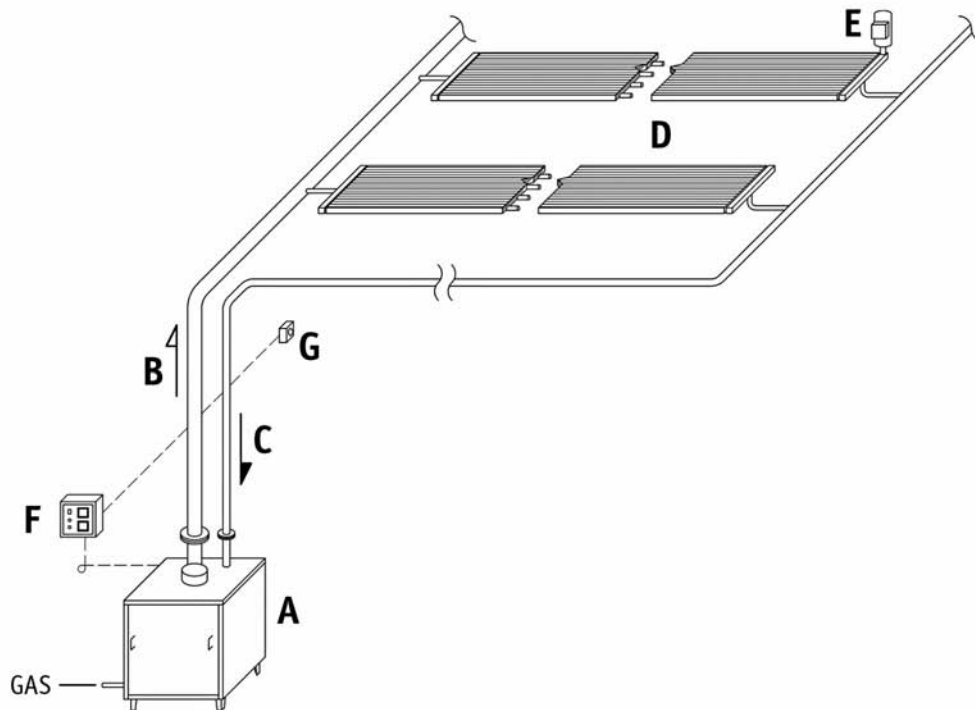

As the entire system is a closed circuit, when the air is extracted, being non-condensable, a vacuum is created.

When igniting the burner in the boiler, steam is immediately formed (in vacuum conditions, steam is formed at low temperatures), which by physical law (the balance of pressure) expands spontaneously throughout the system, irrespective of the length of the pipes and the number or surface area of the radiant heating panels.

The heating panels radiate the heat received from the steam, which in turn condenses, and returns to the boiler by gravity. It is important to highlight how the condensation process is isothermal: there is therefore no temperature drop along the heating panels. The cycle is repeated continuously while the burner is operating. The operation of the system is controlled in an extremely simple manner, using the radiation sensor **G** installed in the environment heated.

The fundamental condition for the perfect operation of the cycle is that there is no air in the circuit. This condition is ensured by the special ASA air venting device **E** that, exploiting the physical characteristics of steam and air, expels all the air from the circuit, without any steam being released.

This venting procedure is performed automatically when the system is first started, without the system is full of air and during operation to vent any infiltration.

SAVINGS

- **No heating plant required:** the VAS steam generator can be installed on the outside of the environment being heated, against a wall, and simply being protected against the weather. Otherwise, the generator can be installed inside a small heating plant, where no other accessories need to be installed (manifolds, expansion vessels, pumps, etc.).
- The average life of the Duck Vap heating panel is much longer than other types of systems.
- Only limited maintenance is required, involving the steam generators only, which are installed in easily accessible locations.
- Almost non-existent electricity consumption.
- Insurance companies apply different fees in relation to the level of risk involved with the various systems. The Duck Vap vacuum steam systems are amongst the most advantageous in these terms.

FLEXIBILITY

- Systems can be developed with generators starting from 63 kW and upwards, without any limits. High capacity systems can also be sub-divided into independent zones, thus ensuring flexibility of operation and savings in running costs.
- The low thermal inertia of the system means that heat is produced very quickly, with an immediate response to changes in the outside climatic conditions, meaning significant energy savings compared to systems with high thermal inertia (i.e. floor heating). The system is therefore especially suitable wherever sporadic and intermittent heating is required.
- If the system requires air curtains or terminals to bring in outside air to compensate for any exhaust from the inside, the solution with a Duck Vap vacuum steam system allows the heating panels to be combined with Sabiana Atlas series air heaters (contact the Sabiana TECHNICAL DEPARTMENT for more details).
- The assembly of the Duck Vap heating panel on the ceiling allows the total use of the walls and the floor area.

RELIABILITY

- The operation of the system is based on physical principles that do not change over time and, therefore, even after many years, operation remains unaffected. The absence of moving parts or mechanical accessories and the complete lack of deposits and corrosion means that the system is always maintained in the same conditions.
- There will be no problems with frost when the system is off, as the pipes are empty and the generator, with a low water content, can easily absorb without damage the increase in internal pressure. It is therefore recommended for all environments where the system may need to be left off for an extended period.
- Extremely functional and easy-to-use temperature control system.



Advantages of the system

COMFORT

- Uniform distribution of the heat, without air movement and with a uniform room temperature throughout the heated area. Other radiation systems with much higher temperatures very often require distances between the radiators that are much greater than the height of installation, with significant differences in temperature within the same environment between the zones underneath the radiators and the intermediate zones.
- The system has no moving parts nor fans, and as a consequence is absolutely silent. Only when the system starts up is there a slight ticking sound due to the expansion process of the pipes and the metal panels.
- The steam vacuum operation allows an average surface temperature of the panels of 95°C, which is optimum for heating non-delimited zones in large industrial environments.

SAFETY

- The system has no moving mechanical parts, and no electric motors and therefore there is no danger of fire.

System components: Sabiana VAS series steam generators by Comitec

MODELS	Rated flow-rate Qn Hi (kW)	Rated output (kW)	Maximum pressure (bar)	Max steam temperature (°C)
VAS 63	70	63,7	0,45	110
VAS 95	105	95,5	0,45	110
VAS 143	157,5	143,3	0,45	110

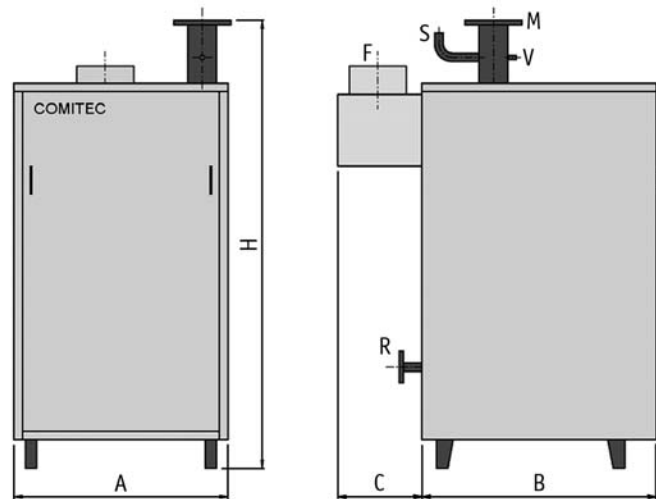

MODELS		VAS 63	VAS 95	VAS 143
Overall dimensions: A	mm	590	750	994
B	mm	820	820	820
C	mm	245	295	320
H	mm	1556	1556	1556
Steam outlet:	Ø M	DN65 PN16	DN100 PN16	DN100 PN16
Condensate return:	Ø R	DN25 PN16	DN25 PN16	DN32 PN16
Safety valve attachment:	Ø S	M 3/4" G	M 1" G	M 1 1/2" G
Vacuum valve attachment:	Ø V	F 1/4" G	F 1/4" G	F 1/4" G
Rated flue diameter:	Ø F mm	180	200	250
Gas supply attachment		F 1/2" G	F 1" G	F 1 1/4" G
Rated heat input Qn (Hi)	kW	70	105	157,5
Rated output Pn	kW	63,7	95,5	143,3
Appliance category		II _{2H3+}	II _{2H3+}	II _{2H3+}
Type of appliance		B _{11BS}	B _{11BS}	B _{11BS}
Power factor		91%	91%	91%
I _{2H} gas nozzles : no. / dia. (mm) / dia. pilot nozzle (mm)		4 / 3,7 / 0,5	6 / 3,7 / 0,5	9 / 3,7 / 0,5
I ₃₊ gas nozzles : no. / dia. (mm) / dia. pilot nozzle (mm)		4 / 2,15 / 0,25	6 / 2,15 / 0,25	9 / 2,15 / 0,25
NOx class		1	1	1
Power supply voltage	V	230	230	230
Power supply frequency	Hz	50	50	50
Power input	W	~20	~25	~30
Empty weight	kg	225	290	385
Water content	lt	115	140	180
Test pressure	bar	1,5	1,5	1,5
Max operating pressure	bar	0,45	0,45	0,45

Due to the special constructional characteristics, these steam generators can be configured as modules to achieve higher heat outputs.

System components: Sabiana VAS series steam generators by Comitec

The VAS steam generators are special, new generation high efficiency appliances designed to be used **exclusively with vacuum steam systems**.

The VAS steam generators are floor-standing appliances fitted with an open-flue atmospheric burner and featuring an on/off operation. Due to the production of steam by micronucleation in a vacuum, the generators have been designed with carbon steel exchangers and vertical flues, thus allowing, together with the use of atmospheric burners, a significant reduction in the overall dimensions compared to traditional jet burner generators. The large heat exchange surface, the special stainless steel turbulators and the effective mineral wool insulation further guarantee high efficiency. The figure below shows the main components of a generator:

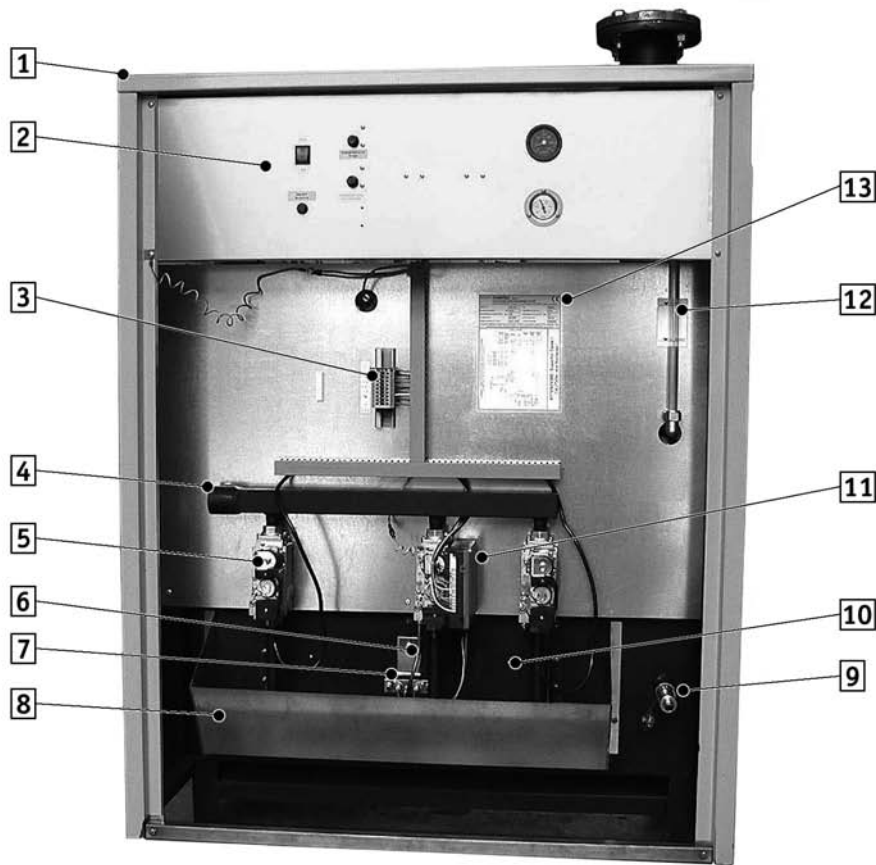

All maintenance and/or testing operations can be performed from the front of the appliance.

To open the front panel of the appliance, open the lock at the bottom with a screwdriver, then grab the two handles on the panel and lift it up (1), pull the bottom out (2) and then slide it downwards (3). To close the panel, perform the same operations in the reverse order.

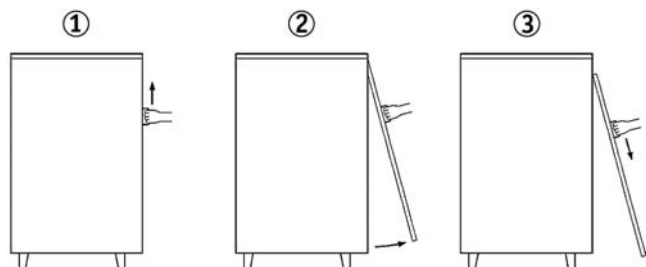

All routine maintenance operations are carried out from the front; the VAS generators can be installed against a wall or in series when the output required is higher than 143 kW. **Outdoor installation is also possible, as long as the appliances are protected against the weather.**

System components: Sabiana VAS series steam generators by Comitec

- 1) **Casing:** made from stainless steel panels with protective film to be removed when installation is complete.
- 2) **Control panel,** also made from stainless steel, including: main ON/OFF switch (A); "Reset" alarm button (B); flue gas thermostat reset button (C) with protective cover; exchanger excess temperature thermostat reset button (D) with protective cover; thermometer (E) for reading the temperature of the appliance; vacuum pressure gauge (F) for reading the pressure in the appliance. As well as these devices, the generator is fitted with an operating pressure switch located in a position that cannot be accessed by the user, as, being factory calibrated, it must not be tampered with.

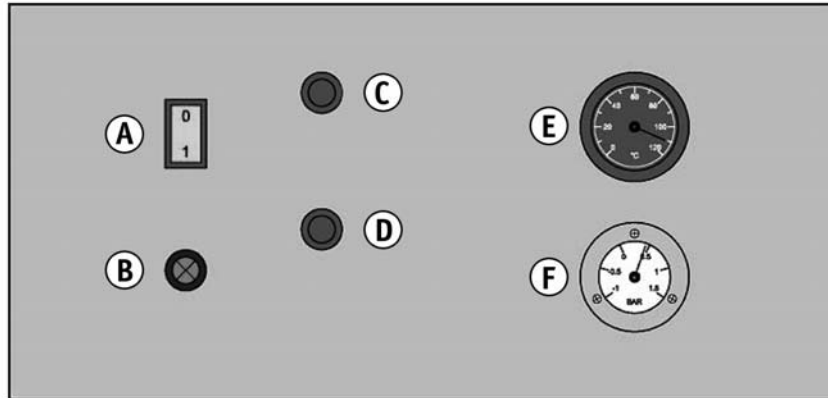

- 3) **Terminal block** for connection to the system management panel
- 4) **Gas fitting**
- 5) **Gas valve:** multifunction assembly with safety and control solenoid valve
- 6) Visual combustion **indicator**
- 7) **Pilot** with intermittent ignition
- 8) Gas nozzle manifold protective **baffle**
- 9) **Valve** for filling/emptying water from the appliance
- 10) **Burner plate** fastened to the individual tubular elements of the burner
- 11) **Ignition control device:** electronic control unit with ionisation flame control
- 12) **Level gauge:** to check the water level in the generator
- 13) **Rating plate** with the data identifying the appliance

SAFETY DEVICES

- **Against failed ignition:** the ionisation flame control shuts down the burner in the event of failed ignition; the anomaly is signalled by the button with indicator light located on the control panel.
- **Against excess pressure:** the safety valve placed on the steam outlet manifold protects the generator against excess pressure.
- **Against excess temperature:** a safety thermostat with manual reset prevents the operation of the burner in the event of excess temperature.
- **Against failed flue gas discharge:** a safety thermostat with manual reset prevents the operation of the burner in the event where the flue gas is not discharged.

System components: Duck Vap series radiant heating panels

For use with in the vacuum steam systems, the Sabiana Duck Vap heating panels have been fitted with special manifolds that allow the uniform distribution of the steam in the 1/2" diameter system pipes. In addition, the air vent and water drain fittings have been eliminated. The fastening system has been especially designed to eliminate the problems caused by the different ways the two materials expand.

OUTLINE OF THE HEATING PANEL COMPONENTS

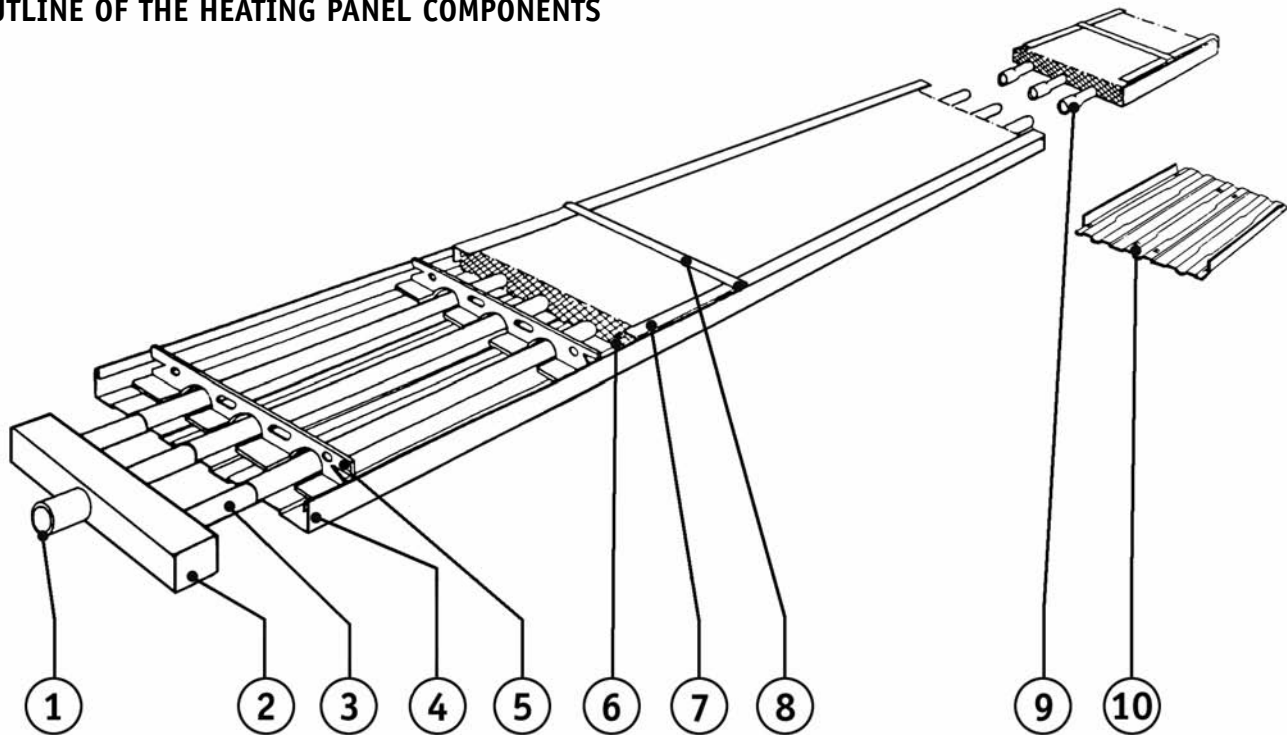

- 1 - Welded attachment (Supply dia. 1.1/4" - Return dia. 1")
- 2 - Header manifold, initial or terminal
- 3 - Steel pipe dia. 1/2"
- 4 - Steel radiant plate
- 5 - Hanging cross-beam
- 6 - Insulation
- 7 - Side edging
- 8 - Insulation fastening straps
- 9 - Pipe flaring to assist coupling
- 10 - Joint cover

System components: Duck Vap series radiant heating panels

Radiant panels made up of:

- Quality steel radiant panel, 0.8 mm thick, cold formed by mechanical forming procedure. The panels, width 300-600-900-1200 mm and length 6 and 4m (3 and 5m upon request), have semicircular self-locking sockets, spaced 100 or 150mm apart, depending on the models and used to hold the hot water pipes.
- Steel pipes pressed into and welded to the radiant panel (1.5mm thick, outside diameter 1/2") created by electric welding quality cold rolled strips and electronically tested in the ironworks. The pipes have belled ends at one side to ease the longitudinal connection of the panels with welding.
- Angle brackets for hanging the panel.
- Initial and terminal headers made by connecting the various pipes in parallel, using manifolds that are welded and factory tested. The manifolds are designed especially for operation with vacuum steam.
- Sized fibreglass insulation (thickness 50 mm) protected at the top by aluminium sheet. Other thickness or configurations upon request.
- Side edging strips made from pre-painted plate sections, to retain the edges of the insulation.
- Pre-painted retaining clips (one each metre) to hold the insulation.
- Shaped and painted make-up joints, with fastening bars, to cover the joint areas.
- Protection with special phosphate de-greasing and epoxy polyester coat, dried in a furnace at 180°C. Colour RAL 9002 (light grey) or RAL 9010 (white). Other RAL colours upon request. The treatment is not suitable for the outdoor installation of the radiant panels.

System components: Duck Vap series radiant heating panels

MODULAR WIDTHS

VAP 2 - 1/2" dia. pipes, 150mm step.

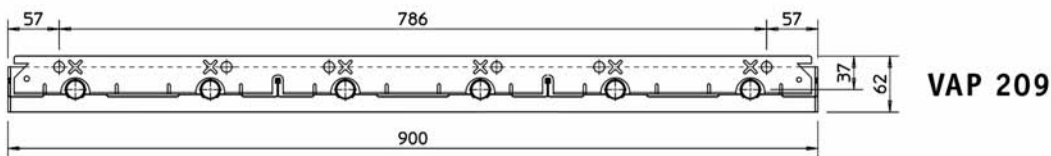
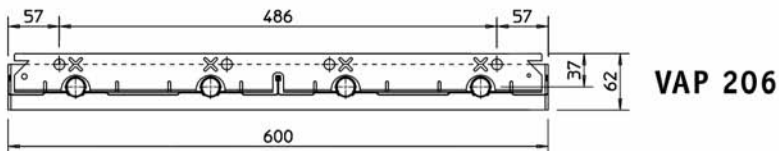
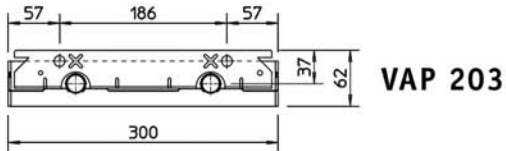

VAP 3 - 1/2" dia. pipes, 100mm step.

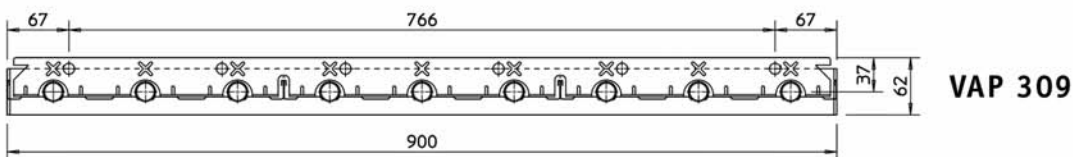
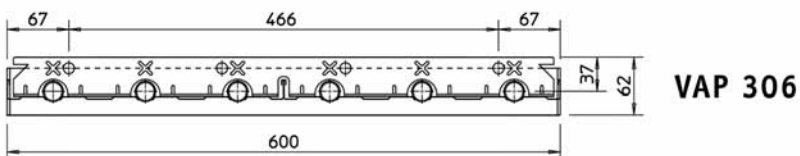
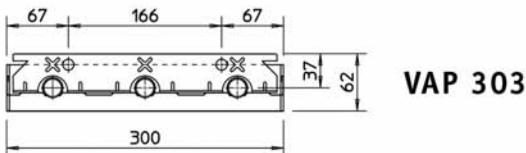

MODULAR LENGTHS

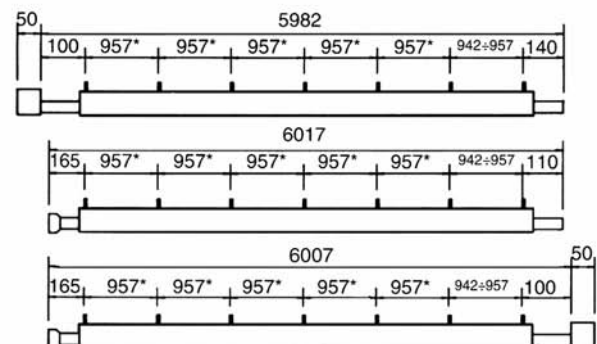
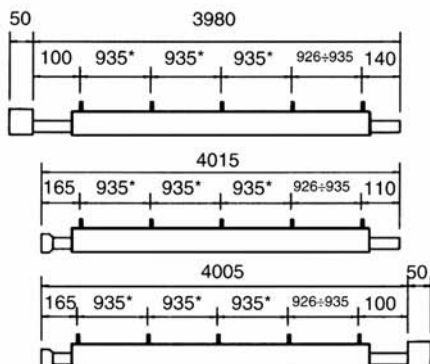

* ± 3 mm.

Upon request, elements of other lengths can also be supplied.

System components: Duck Vap series radiant heating panels

HEAT OUTPUT OF THE HEATING PANELS

Carrier fluid: steam at 110°C (P = 0.45 bar)

Model	T _{room} = 16°C	T _{room} = 18°C	T _{room} = 20°C
	W/m	W/m	W/m
VAP 203	312	304	296
VAP 206	556	543	529
VAP 209	785	766	747
VAP 303	383	374	364
VAP 306	680	664	647
VAP 309	991	966	942

MANIFOLDS AND FITTINGS

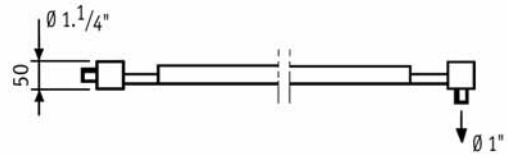
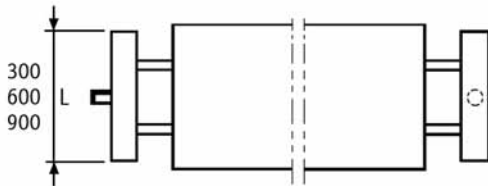

TABLE OF THE COMPOSITIONS OF THE INTERMEDIATE AND TERMINAL ELEMENTS LENGTHWISE (WITH STANDARD 4 AND 6m MODULE)

Totale length m	Composition		
	Initial element	Intermediate element	Final element
4	1 x 4 m		
6	1 x 6 m		
8	1 x 4 m		1 x 4 m
10	1 x 4 m		1 x 6 m
12	1 x 6 m		1 x 6 m
14	1 x 4 m	1 x 6 m	1 x 4 m
16	1 x 4 m	1 x 6 m	1 x 6 m
18	1 x 6 m	1 x 6 m	1 x 6 m
20	1 x 4 m	2 x 6 m	1 x 4 m
22	1 x 4 m	2 x 6 m	1 x 6 m
24	1 x 6 m	2 x 6 m	1 x 6 m

For lengths above 24m, contact the Sabiana TECHNICAL DEPARTMENT.

UNIT WEIGHTS

Model	VAP 203	VAP 206	VAP 209	VAP 303	VAP 306	VAP 309
Unit weight (kg/m)	4	8	12	6	12	18

System components: Sabiana ASA air venting device by Comitec

The natural vacuum steam circulation systems require a vacuum as the fundamental condition for their operation.

Experience has shown that the vacuum produced using vacuum pumps is physically limited by the water vapour tension at room temperature and mechanically limited by the characteristics of the pump itself. In addition, over time the quality of the vacuum may decline due to micro-porosity that is not easily detected in the systems (pores in the welding or imperfect seal of the flanged joints).

To overcome this problem, a new air venting device has been designed and built, called ASA. This device produces a good level of vacuum when first starting the system, and then improves and maintains it over time. Installed at suitable points in the system, it does not use mechanical means to remove the air from the circuit, but rather exploits the force of the steam to expel the air. Based on the internal operating logic, it is able to detect the presence of air and then vent it until the steam arrives. In this way, only the air is expelled, and the consequent vacuum created is undoubtedly better than could be achieved mechanically, as it is not limited by the water vapour tension nor by the characteristics of the vacuum pump.

The figure below shows the main components:

- 1) Level sensor;
- 2) Air vent solenoid valve;
- 3) System pressure indicator light;
- 4) Vent in progress indicator light;
- 5) Box for the control equipment;
- 6) Temperature probe;
- 7) 3/4" gas fitting.

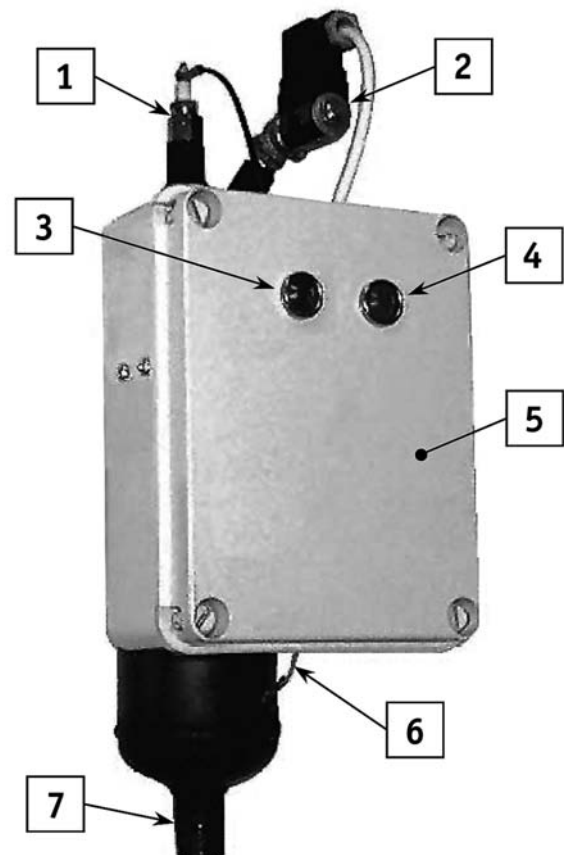

System components: control panel

Model **QP1** Control of 1 steam generator

Model **QP2** Control of 2 steam generators

The management of a radiation system requires a room probe that does not measure the air temperature as in the case of traditional systems, but radiation (emission of infrared rays). The control panel supplied by Sabiana is especially designed for radiation systems and allows the user to manage the system simply and effectively, with the possibility to program the digital clock with the weekly operating time bands for two separate temperature values, "day" and "night".

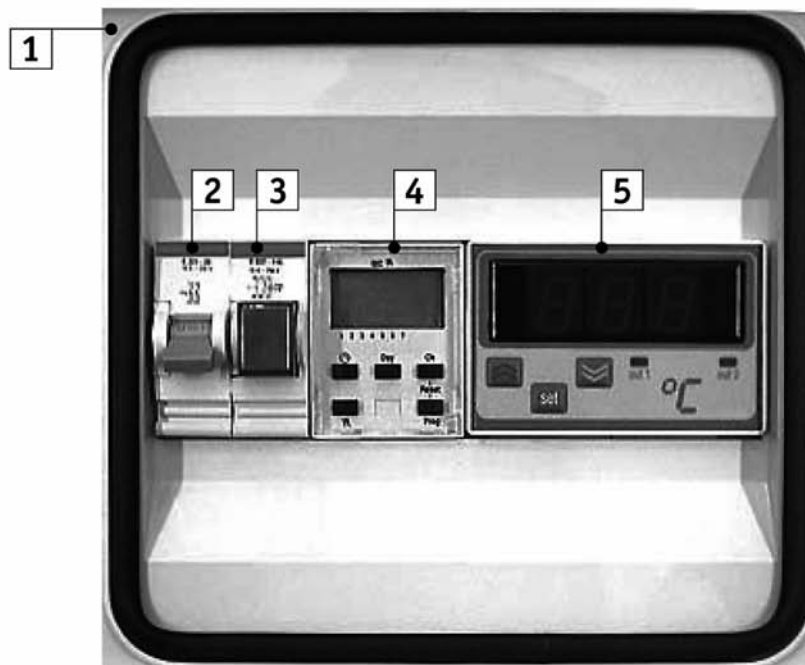

The figure shows the main components on the panel:

- 1) control unit for wall mounting, index of protection IP65;
- 2) main on/off switch;
- 3) button with indicator light to signal burner shutdown and reset;
- 4) digital weekly on/off timer for setting the operating time bands at the "day" temperature; possibility to switch from automatic to manual operation; display of the status (on/off) of the relay;
- 5) digital electronic thermostat with two temperature thresholds, "day" (comfort) and "night" (reduced); display of the status (on/off) of the two relays;

A detailed description of the programming operations is contained in the instructions provided with the panel.

In the case of systems with a series of modules installed, the panel will be much the same, yet with a number of reset buttons corresponding to the number of appliances.

The black bulb room probe is supplied with the control panel.

CALCULATING HEAT LOSS

For the calculation of the heat loss from a building, refer to the new EUROPEAN STANDARD EN 12831, published in March 2003 and translated into all European languages.

The standard requires the use of the operating or operative temperature as the temperature inside the environment (arithmetic average of the inside air temperature and the mean radiant temperature).

The heat loss must be calculated using this value.

Considering that two well-insulated buildings, one heated with radiant heating strips and an operative temperature of 15°C, the other heated with air systems and an air temperature of 18°C, give a similar feeling of comfort, thanks to the different temperature of the floor and the walls, for the correct sizing of the heat loss of the building it is fundamental to carefully define the room temperature with the final user, striving for energy savings for the same level of comfort, which may involve a temperature that is 3°C lower.

The EN 12831 standard in the English version, converted in the same way in France by the Association of Systems Designers, introduces the same concepts in Annex B.1, Table B.1, proposing for large buildings with a height of over 5m, a difference of between 15% and 30% in the calculation of the total heat loss of the building depending on whether radiant heating strips or forced air heating systems are used.

If the inside air temperature differs considerably from the mean radiant temperature (e.g. with a radiant heating strip system), the same EN 12831 standard, in Annex B.2, suggests the calculation of the part of the heat loss due to the infiltration of air, comparing the outside temperature with the inside air temperature and not with the operative temperature. In the example of an environment with an operative temperature of 15°C, mean radiant temperature of 17°C, inside air temperature of 13°C and outside air temperature of -15°C, adopting this suggestion involves a reduction of over 5% in the calculation of the heat loss due to the infiltration of outside air.

LENGTH OF RADIANT PANELS

Apart from the case in which certain structural needs (lights, dividing walls and beams etc.) or the Lay-out (shelves) must be observed, it is recommended to install radiant panels parallel to the longer side of the building to be heated.

This will allow the assembly of longer radiant panels sections therefore reducing the number of runs. This will have the consequence of less connections to the pipework which will achieve a lower installation cost. At the same time this will reduce the quantity of tubes necessary for the distribution of the heating fluid. The maximum lengths of the radiant panels are 24 m.

The radiant panel length must cover the whole area to be heated.

Free space between the radiant panels and the walls (or limit of the area to be heated) is normally between 1 and 2 metres.

CHOICE OF MODEL

After determining the length of radiant panels, it is possible to choose the suitable model. Once the running conditions (air temperature, water temperature, installation height) are known, it is possible to check the thermal output of various models on the table on page 13. Assuming that the VAP 309 model is used (that is the one with the highest thermal emission), the total thermal power to be installed is divided by the panel thermal output for each linear metre (already de-rated from any correction factor) and the number of total metres for this model found. Then by dividing this value by the maximum length of each panel the (rounded off) number of panels to be installed will be found.

$$\frac{\text{Total power}}{\text{Output} \times \text{m.}} = \text{Tot. m.} \qquad \frac{\text{Tot. m.}}{\text{Length}} = \text{N}^\circ \text{ of panels}$$

At this point, the panel emission for each linear meter must be multiplied by the number of total meters obtaining the total emission of the panels that must cover the 100% of the requested total heat losses.

The first check consists of verifying that the distance between two panels is lower than the installation height. If the distance between centres exceeds the installation height, the number of panels must be increased by using the type of radiant panel with a thermal emission immediately below the one of the previously chosen model (e.g. VAP 209 instead of VAP 309) and by repeating the above procedure.

Tests and practice have shown that an even distribution of radiant heat over a central area in a building (where the cooling effect of the walls can be considered as 0) is achieved when the distance between Duck Vap panels is the same or less than the height from the floor.

For example when Duck Vap panels are installed at a height of 5m from the floor then the distance between the panels must be 5m or less to obtain the best heating coverage.

**Correct installation
radiant panels
Duck Vap**

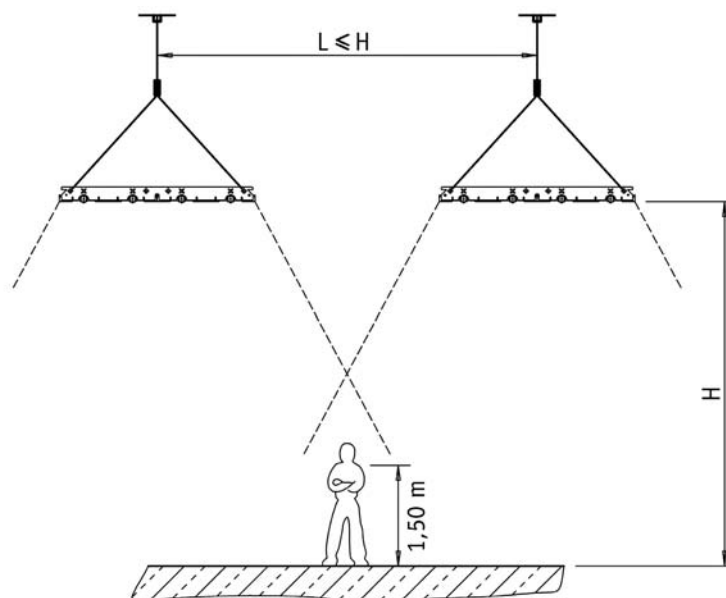

Sizing the installation

STEAM PIPES

The table below shows the flow-rates of steam in kg/h for the different diameters of pipes, for steam at the standard operating conditions of the steam systems under vacuum, that is, 109.5°C, 0.4 bar, specific volume 1.225 kg/m³, latent heat 533.3 kcal/kg, with speeds of 15, 16 and 17 m/s

**TABLE OF STEAM FLOW-RATE AT 0.4 bar - 109,55°C - 1,225 kg/m³
FLOW-RATE Q (kg/h)**

Rated diameter		15 m/s	16 m/s	17 m/s
DN 25	1"	27	29	31
DN 32	1"1/4	44	48	51
DN 40	1"1/2	61	65	69
DN 50	2"	101	108	114
DN 65	2"1/2	170	181	192
DN 80	3"	233	248	264
DN 100	4"	389	415	440
DN 125	5"	585	624	663
DN 150	6"	886	945	1004
DN 200	8"	1497	1597	1697
DN 250	10"	2339	2495	2651

In the vacuum steam systems, it is recommended to use the values shown in the following table so as to achieve optimum and silent operation:

Rated diameter		MINIMUM	MAXIMUM
		kW	kW
DN 25	1"	0	11,61
DN 32	1"1/4	11,6	18,6
DN 40	1"1/2	18,6	25,6
DN 50	2"	25,6	46,5
DN 65	2"1/2	46,5	69,8
DN 80	3"	69,8	98,8
DN 100	4"	98,8	209,3
DN 125	5"	209	348,8
DN 150	6"	349	639,5

IMPORTANT: to ensure optimum operation, it is recommended not to use diameters below 2" for the steam lines; lower diameters can only be used for the construction of the sections of steam lines running to the manifolds of the heating panels.

CONDENSATION PIPES

The condensation in vacuum steam systems is totally recovered.

Each kg of steam that condenses is transformed into one kg of water, which corresponds to one litre.

To achieve natural and trouble-free circulation, the horizontal sections must have a slope of **at least 1%**, using pipes with the diameters shown in the following table:

Rated diameter		Max flow-rate	Max heat input
		kg/h	kW
DN 20	3/4"	65	41,9
DN 25	1"	109	69,8
DN 32	1"1/4	455	209,7
DN 40	1"1/2	1.090	697,7

WARNING: the use of the 3/4" diameter is only recommended for the construction of the sections between the manifolds of the heating strips and the condensation lines.

N.B.: The steam and condensation pipes must be supported so as to allow the free expansion of the heating panels and the pipes themselves.

SELECTING THE STEAM GENERATOR

The steam generator should be selected based on the heat output of the heating panels, and not on the heating requirement; as a rule, choose **a steam generator with a rated (useful) output that is at least 10% higher than the heat output of the heating strips.**

POSITIONING THE GENERATOR

The generator, for technical reasons (return of the condensation by gravity), must be positioned at a lower level than the heating panels. For the correct operation of the system, the difference in height must not be less than 2÷2.5 m.

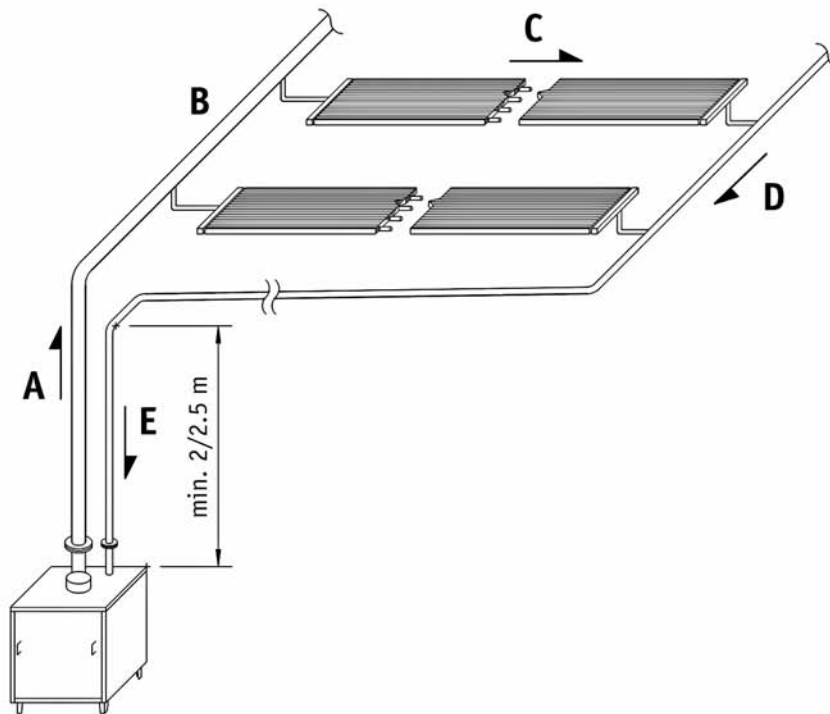

Figure 1

In the case of industrial facilities, the generator is normally positioned on the ground floor; alternatively, it may be installed on the ceilings of ground floor rooms, as long as the minimum height difference indicated is observed.

As regards the characteristics of the room where the generator is installed, the distance from the walls, the aeration openings etc. must comply with national and local legislation in force.

If there is no boiler room in the building, or it cannot be used for the installation of the generators, they can be installed outside, protected by a suitable structure (box or cabin) against the weather (rain, snow, wind etc.).

The generator is fitted with its own control and safety devices and does not require the installation of any accessories. In fact, it simply needs to be connected to the gas line and the electrical control panel. As regards these connections, the relevant standards in force must be complied with.

The system as a whole represents a closed and sealed circuit, therefore no water supply connection is required.

STEAM AND CONDENSATION LINES

Once the output and layout of the system has been defined, the flow-rates of steam and condensation can be calculated in each section and consequently, using the tables shown in the corresponding paragraphs, the diameter of the pipes.

Once having defined the diameters, the trend of the pipes in terms of height must also be established, following the **fundamental concept that there must be no pockets of stagnation of condensation in the outlet and return lines and in the heating panels themselves**. Such pockets may lead to the malfunction of the system, as well as the production of annoying noises (water hammer).

Figure 1 represents the ideal layout of a system:

- section A (steam outlet) is vertical, and therefore there is no possibility for condensation to stagnate;
- section B (steam outlet) is horizontal; there is no accumulation of condensation, as this is drained to the heating panels through the steam outlets located on the pipes. The sections from the main line B must be attached flush with the pipes to allow draining, and must penetrate inside. Any adapters used must be eccentric. If using concentric adapters, the pipes must be perfectly level or slightly inclined back towards the previous steam outlet;
- the heating panels C should be installed with a slope of at least 1%;
- section D (condensation return) should be installed with a slope of 1%; there must be no traps nor any horizontal sections;
- the vertical section E (condensation return) finally carries the condensation back to the generator, where the cycle begins again.

N.B.: the steam outlet pipes should be insulated, except for the connections to the manifolds; the condensation return pipes should only be insulated in any outdoor sections.

At times, due to architectural limits, sections of the condensate return pipes need to be buried, as shown in Figure 2. In this case, the insulation should cover the indoor section for a height of around 3m, the underground section and the final section connecting to the generator.

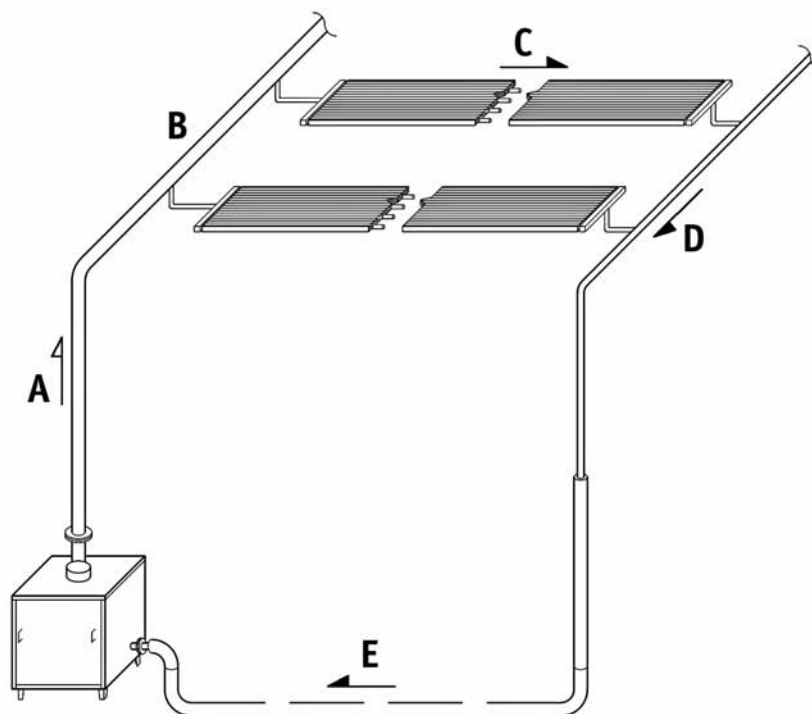

Figure 2

Technical tips

If there are no obstacles, the steam pipes "B" and condensation pipes "D" can be installed in line with the manifolds (the steam pipe on top, the condensation pipe below, as shown in Fig. 3); in this way, the steam and condensate sections can be attached using straight rather than elbow attachments. The steam pipe can be installed level, while the condensation return pipe must always have a minimum 1% slope (in this case, the outlet manifolds must be made especially with the fittings facing upwards).

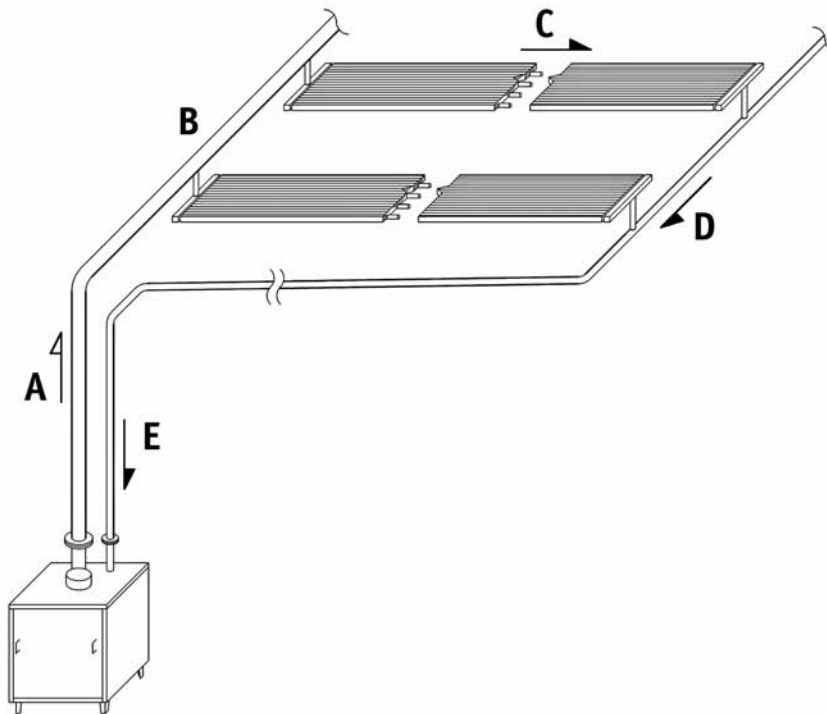

Figure 3

Figure 4 shows a system in which for technical or architectural reasons the heating panels must be located above the steam outlet pipe. In this case, section B must be installed with a back-slope of least 0.5% towards the generator, so as to drain the condensation.

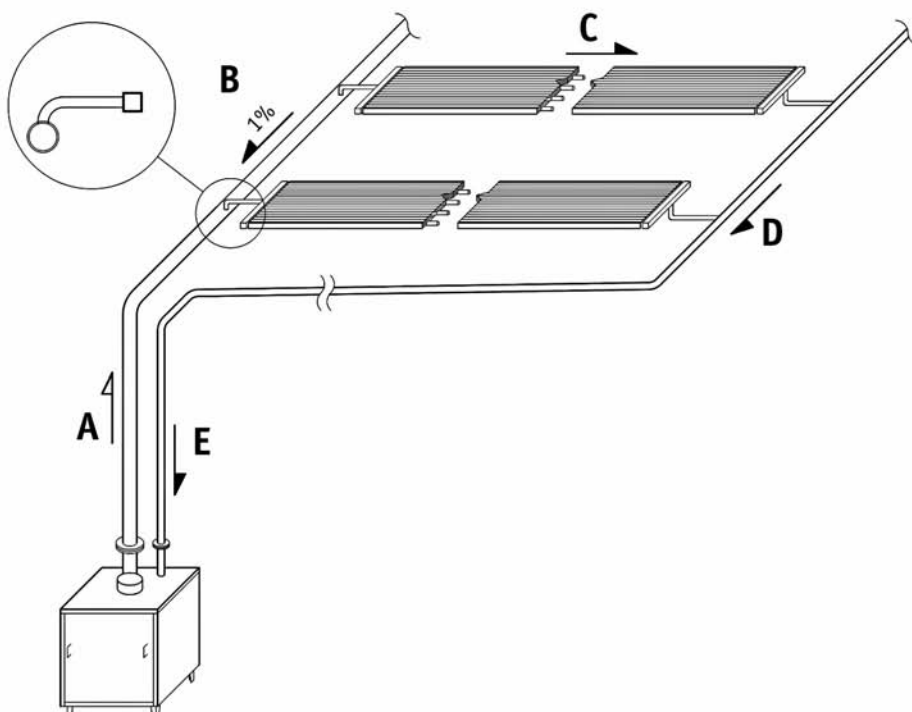

Figure 4

If a low point P (Figure 5) is required in the outlet pipe, this must be drained via a pipe, with a slope of 1%, connected to the condensation return; a drain trap must be fitted, as shown in the figure.

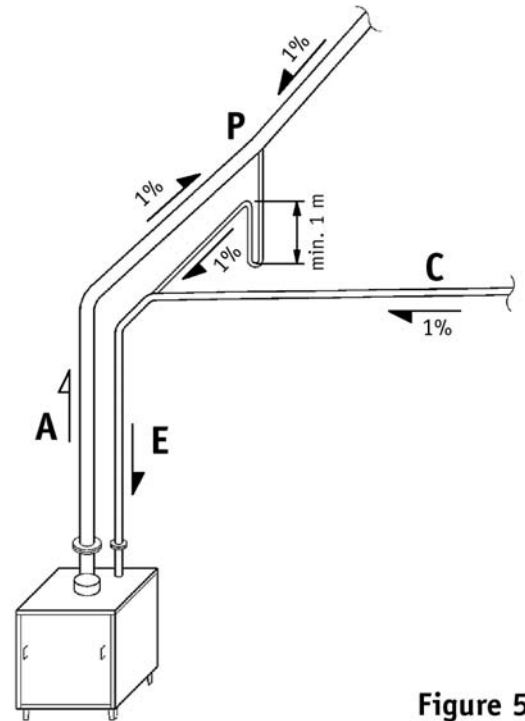
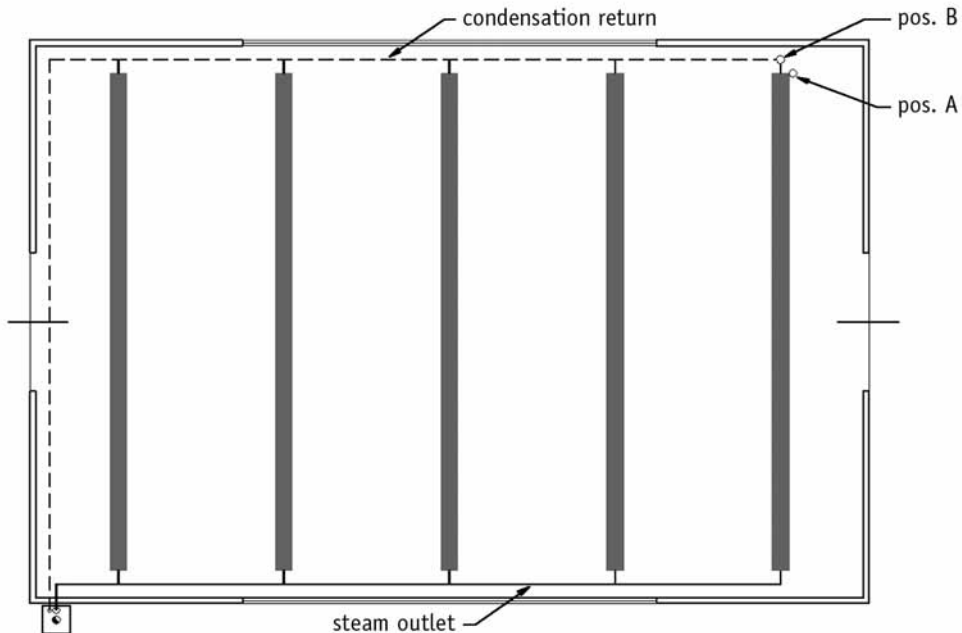

Figure 5

N.B.: To support the Duck Vap heating panels, refer to the “Duck Strip Radiant Heating Panels” catalogue.

POSITIONING THE ASA AIR VENTING DEVICE

The ASA device vents any air remaining in the system. The possible positions for the installation of the device in a typical system are shown in the figure below.



The figure indicates two alternative positions:

- in position "A", the ASA is installed above the condensate manifold of the heating panels;
- in position "B", the ASA is installed at the end of the condensation return.

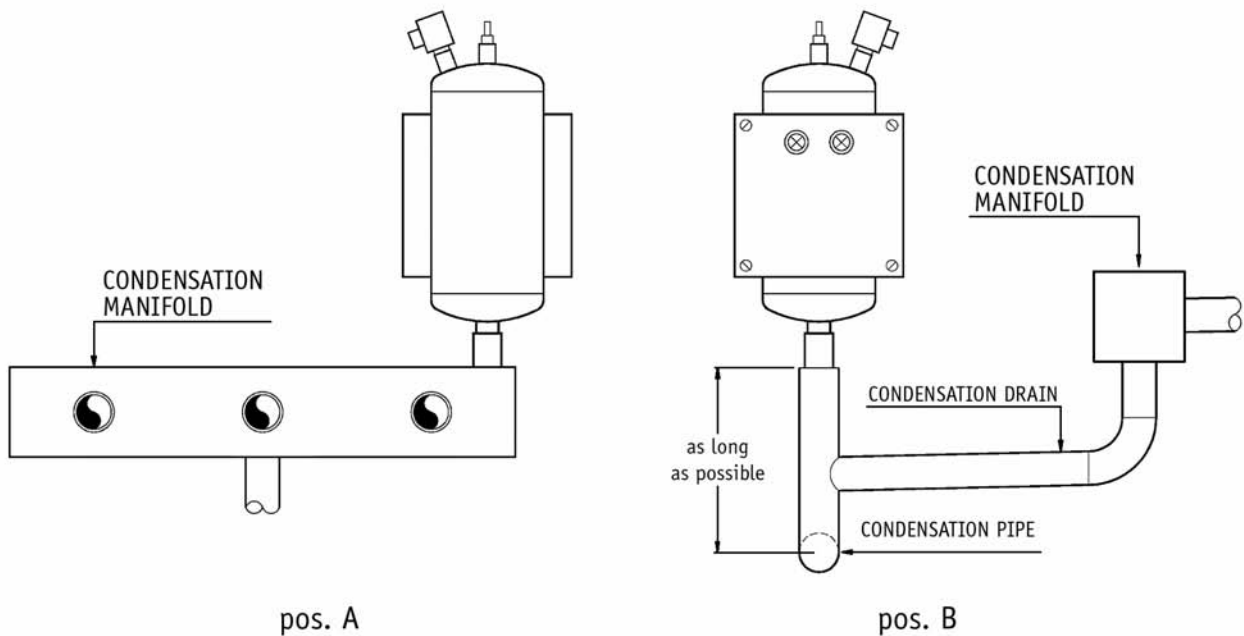

In general, position "A" is the ideal solution and should be used where possible, while position "B" should only be adopted when, due to space reasons, the ASA cannot be installed above the manifold.

If the system has the condensation manifold in the centre as shown in the figure below, two ASA devices should be installed on the sides of the system, as shown in the figure below.

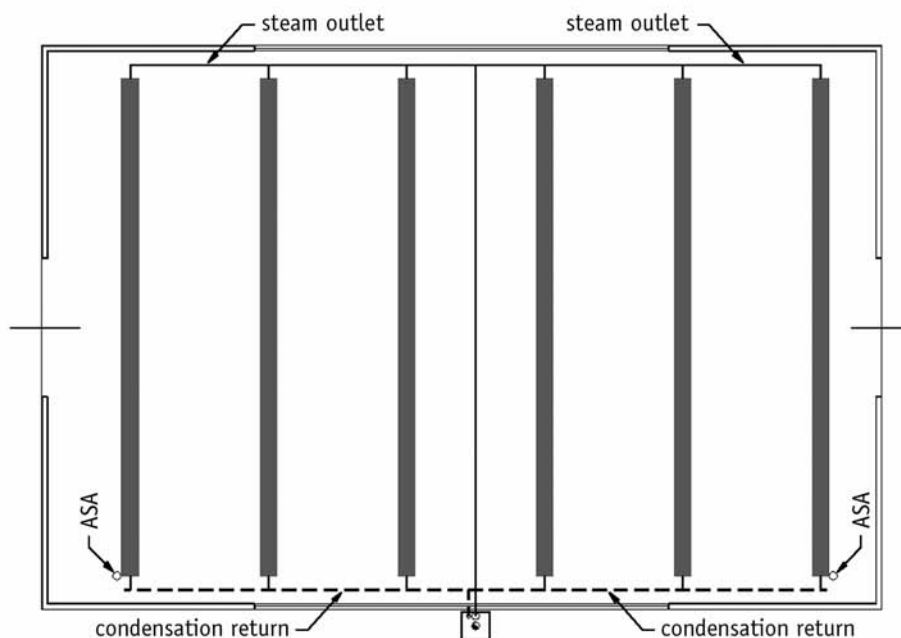

In general, with complex systems featuring many different branches, the criterion for positioning the ASA devices is to place them in those points of each zone that are theoretically the last to be reached by the steam. In practice, as each zone has a rectangular layout, the ASA is installed in a diagonally opposite position to the point where the steam enters the zone.

N.B.: For special systems, contact the TECHNICAL DEPARTMENT.

ELECTRICAL CONNECTIONS

The operation of the system is controlled using the control panel described previously. The figure below shows the wiring diagram for a system with a VAS series generator.

COMPONENTS IN THE PANEL

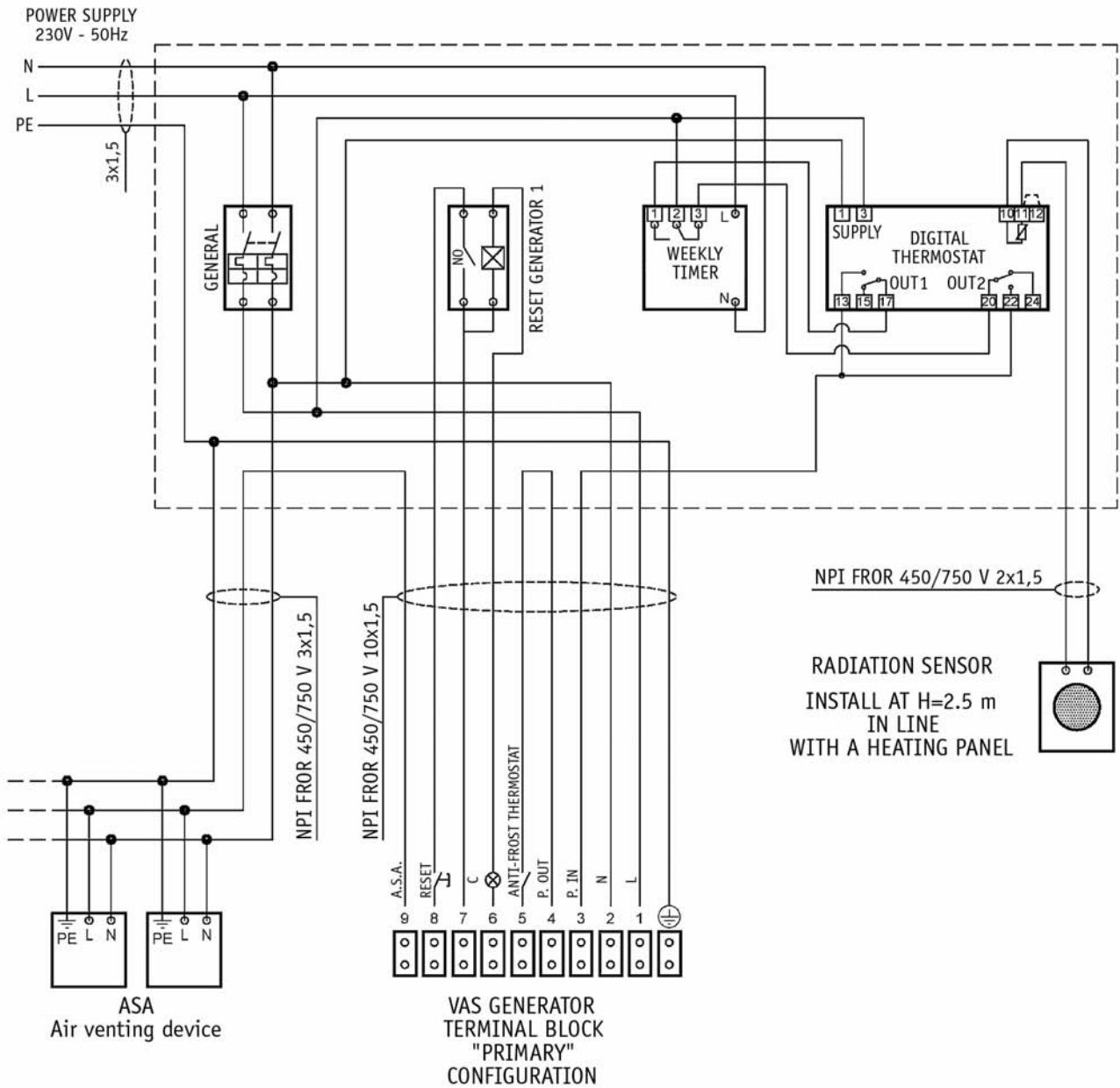

The control panel can be installed in the most convenient position for the user; it should be powered at 230V - 50 Hz. From the panel run the power cable to the ASA unit/units, the multi-wire connection cable to the generator and the connection cable to the radiation sensor, which should be installed inside the environment being heated **in line with a heating panel, at a height of around 2.5m.**

The figure shows the layout of a standard panel for one VAS generator. If more than one generator is installed in series, refer to the wiring diagrams supplied together with the panel.

GAS PIPE CONNECTIONS

The gas pipe must be completed by authorised personnel in compliance with the relevant technical and safety standards in force, using materials suitable for the purpose.

The cross-section of the supply pipe must be suitable for the heat output installed and the length of the pipe, so as to guarantee the minimum supply pressure.

The gas pipe must be connected to the boiler via an on-off valve, using a hose with a union nut, so as to allow the easy removal of the burner for maintenance. The sections of rigid pipes near the appliance must also be installed so as to allow the burner to be removed.

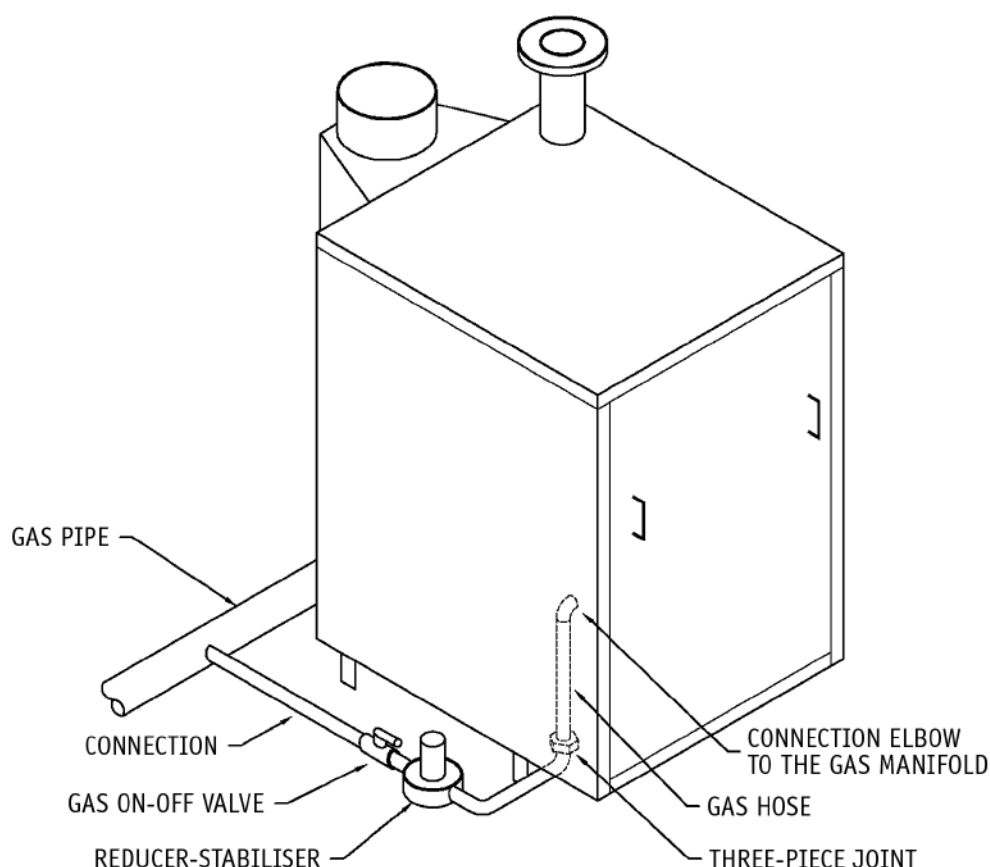

For the VAS series generators with atmospheric burners, no filters and/or stabilisers need to be installed, while in the case of particularly long gas pipes supplying two or more generators, these components may be necessary. The decision to install such components is left to the judgment of the designer or the installer.

The descriptions and illustrations provided in this publication are not binding: Sabiana reserves the right, whilst maintaining the essential characteristics

of the types described and illustrated, to make, at any time, without the requirement to promptly update this piece of literature, any changes that it

considers useful for the purpose of improvement or for any other manufacturing or commercial requirements.

Commercializzatore /
Marketer

SABIANA S.p.A.

Tipo apparecchiature/
Appliances type

**Generatori di vapore
Steam generator**

Rapporto di conformità tecnica nr. /
Test report no.

163842

Marchio / trade mark:

VAS

Modelli / models:

VAS 63

VAS 95

VAS 143

Le sopraindicate apparecchiature soddisfano i requisiti essenziali riportati
nella Direttiva Apparecchi a Gas (90/396/CEE).

*The above mentioned appliances meet the essential requirements as described in
the Directive on appliances burning gaseous fuels (90/396/EEC).*

San Vendemiano, **07 Giugno 2004**

San Vendemiano, 07 June 2004

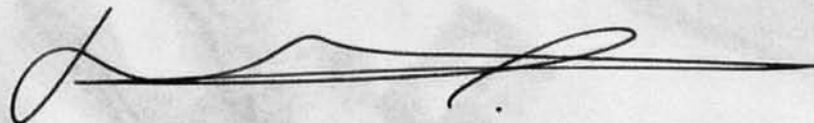

Daniel Vangheluwe
Vice presidente.
Vice president

GASTE C

GASTE C Italia Spa
Treviso 32/34
31020 San Vendemiano (TV)
Italia

GASTE C

ATTESTATO

Heating
Duck Vap Radiant Heating Panels
Vacuum Steam Heating System



SABIANA

ENVIRONMENTAL COMFORT