

Modular Air Conditioners



MAC **Modular Air Conditioners**
with Electrostatic Filter Section

CONTENTS

Introduction	page 3
Construction features	3
Sections dimensions and weights	4
Operation limits	5
Connection side	5
Combination possibilities	6
MAC performance data	7
MAC-ECM performance data	10
MAC / MAC-ECM air side pressure drop	14
Heating emission tables	16
Cooling emission tables	24
Selection example with SVE fan section	28
Selection example with SVE-ECM fan section	30
Accessories (optional) - Valve Kit	32
Electrostatic filter	34
Accessories (optional)	37
MAC wall electronic controls	42
MAC-ECM wall electronic controls	44
Wall electronic controls accessories	47
Controls and units MB version	48
Management system	51

HORIZONTAL UNIT



SECTION WITH ELECTROSTATIC FILTER AND CARBON FILTER



VERTICAL UNIT



Introduction

Thanks to its expertise in the heating and air conditioning field now it presents you with the MAC series of slim-line air conditioners. They are constructed in four basic versions in order to satisfy any installation request. By the use of the same modular components 6 vertical and 9 horizontal versions can be obtained. It is also possible to mount either 2, 3, 4 or 6 row heat exchangers for water, or a 4 row heat exchanger for the direct expansion of refrigerated gases in the treatment section.

The available air volume ranges
from 600 to 1400 m³/h on model 1,
from 1000 to 2100 m³/h on model 2,
from 1500 to 3000 m³/h on model 3
and from 2400 to 4500 m³/h on model 4.

Thanks to its modular construction the unit can be easily disassembled and re-assembled on site and the air flow direction can be changed according to the specific needs. Additional features like condensate collection trays, humidification etc. can also be easily added later.

The special construction makes the inspection and the removal of the fan assembly and heat exchangers extremely easy.

Construction features

Casing consists of self-supporting panels in hot dip galvanized, prepainted steel, which are completely insulated with a 20 mm thick, thermoacoustic, flame retardant lining.

Fan section with asynchronous motor (MAC version): for the models 1, 2 and 3 consists of centrifugal fans in galvanized steel with two impellers, and one directly coupled three speed motor. Model 4 consists of two motors with external rotor directly coupled to the impeller. The supply is single phase 230V - 50Hz, with permanently installed capacitor, insulation class F.

Fan section with EC brushless electronic motor and inverter board (MAC-ECM version): consists of centrifugal fans in galvanized steel with two impellers, and one directly coupled ECM motor directly coupled to the impellers. The supply is single phase 230V - 50Hz, 0-10V signal.

Heat Exchanger constructed in 3/8" inch BSP expanded copper tubes with aluminium fins with a pitch of 2,1 mm. The steel headers have an extra tapping for an air vent and following male connections:

Sizes 1 and 2 = 3/4"

Size 3 = 1"

Size 4 = 1.1/4" except 6 rows with 1.1/2"

Available **filter** versions:

- regenerable synthetic filter, 48 mm thick, class G3.
- micro-pleated synthetic filter, 98 mm thick, class F7.

Sections dimensions and weights

SVE / SVE-ECM FAN SECTION

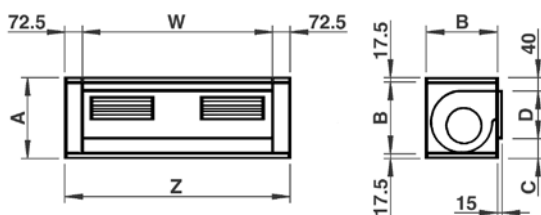

SBO HEAT EXCHANGER SECTION

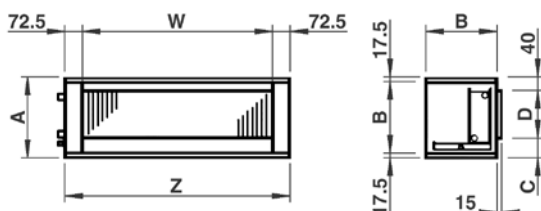

Sections with 4 row coil + 2 row coil

Size 1 = SB4+SB2

Size 2÷4 = SB4+2

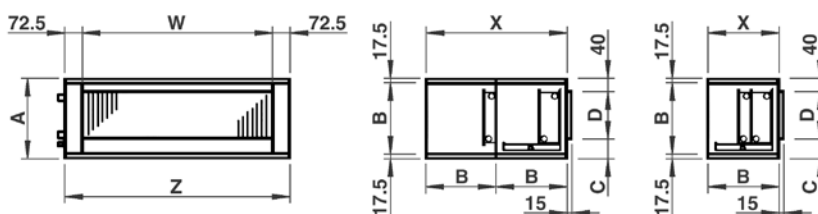

The coil sequence can be modified only in case of a specific request when placing the order.

SFS FILTER SECTION

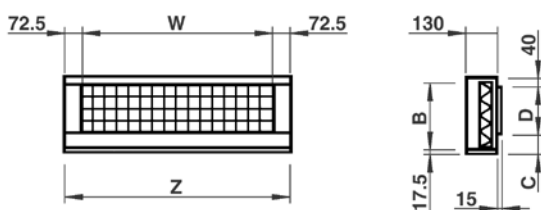

The standard filter extraction is from the bottom, any different need must be specifically requested.

		SECTIONS WEIGHTS kg				WATER CONTENT liters			
		1	2	3	4	1	2	3	4
SIZE		1	2	3	4	1	2	3	4
FAN SECTION		23	28	32	52	-	-	-	-
COIL SECTIONS	2 ROWS	14	18	22	38	1,05	1,6	2,3	3,6
	3 ROWS	16	20	24	42	1,5	2,3	3,2	5,0
	4 ROWS	18	22	26	45	2,0	3,0	4,1	6,5
	6 ROWS	22	28	34	55	2,9	4,4	6,0	9,7
	4 + 2 ROWS	-	26	30	52	SEE ABOVE			
6 + 2 ROWS	-	32	38	62					

	A	B	C	D	X	Z	W
SIZE 1	335	300	65	195	600	950	805
SIZE 2	415	380	40	300	380	950	805
SIZE 3	515	480	40	400	480	950	805
SIZE 4	515	480	40	400	480	1500	1355

Operation limits

Electric motors

The leaving air temperature must not exceed a temperature of 55°C with 230V 50Hz supply. The air speed through the cooling coils must not exceed 2.6 m/s in order to avoid the condensate entrainment.

Heat exchanger

The heat exchangers are tested to a pressure of 30 bar. In normal operation the water temperature should not exceed 95°C and the maximum working pressure 10 bar. Where a cooling coil is fitted the coil should always be fitted in a vertical position. The heat exchanger is not suitable for use in corrosive atmosphere or in environments where aluminium may be subject to corrosion.

Connection side in relation to the air flow direction

(it must be specified on the order)

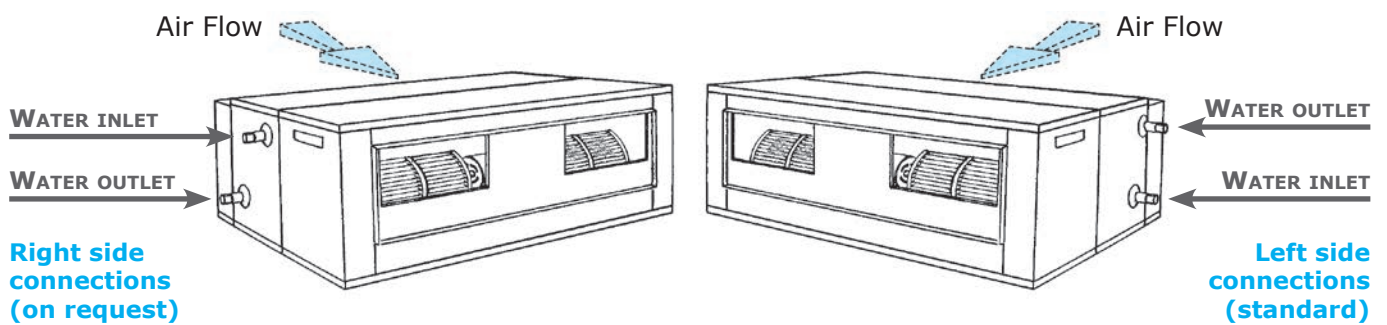

Combination possibilities

In addition to the 12 versions available using standard components a wide range of further combinations can be achieved and for each of them you can choose between the four different types of heat exchanger.

The sizes 1, 2, 3 and 4 of the MAC air conditioner can be supplied with the electrostatic filter (see page. 34).

Heating and cooling with 1 coil

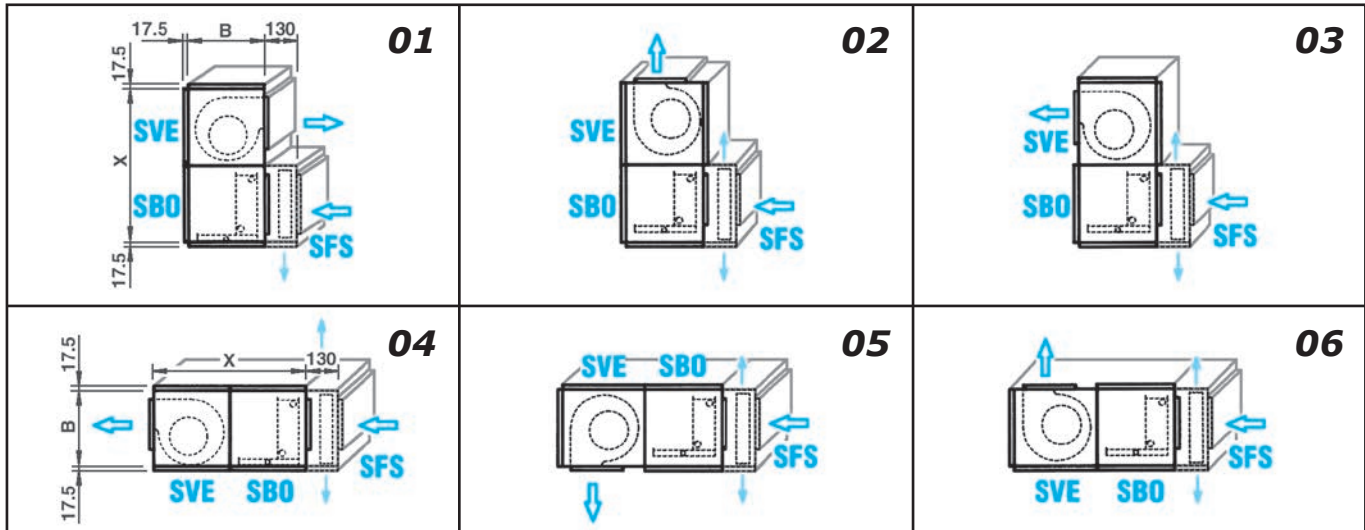

Heating and cooling with 2 coils

Vertical versions: the section with 2 coils can be carried out only as specified in Provision A

Horizontal versions:

- For Size 1, provide a section for each coil (2 sections in total) – Provision B
- For Sizes 2-3-4, the 2 coils can be placed in one section – Provision C

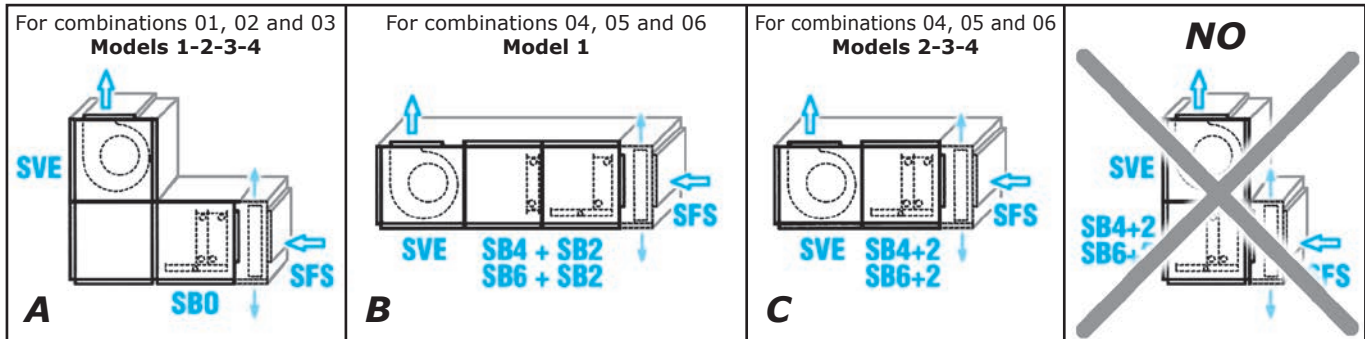

Heating only

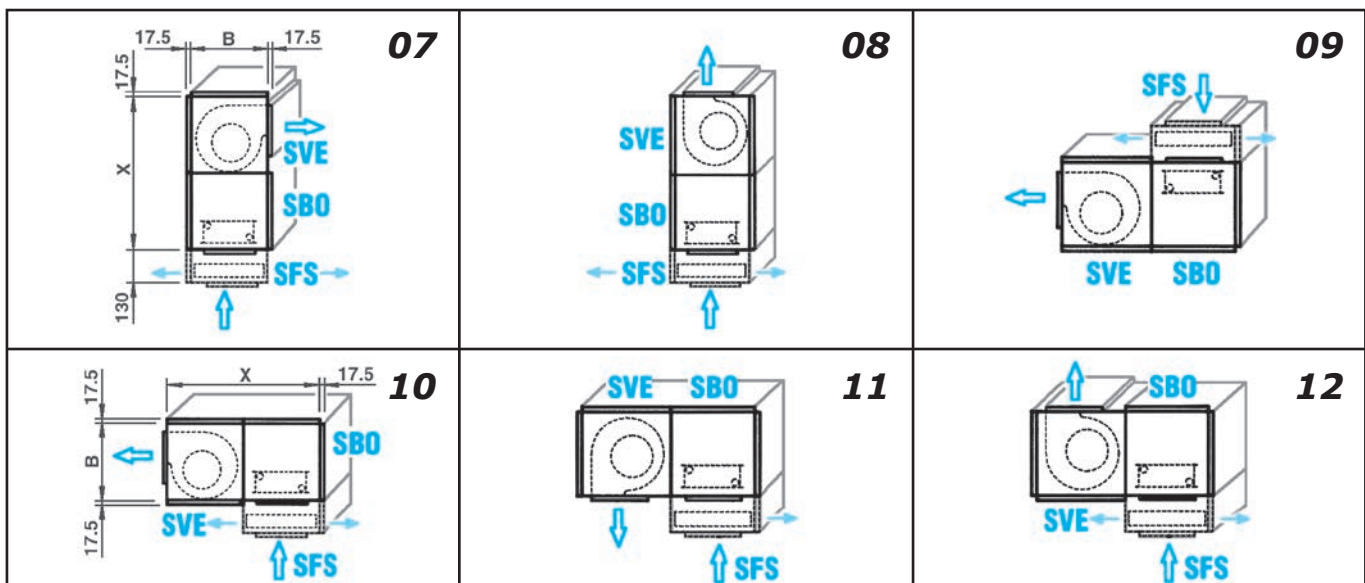

MAC airflow performance

Selection diagrams of SVE fan section with Asynchronous Motor.

The Fan Section is assembled with filtering and air handling sections. The typical curves for unit selection are provided below. Performance curves show fan section typical field of operation, in terms of air flow at specific external static pressures and motor speed.

Absorbed electrical power curves are also provided to the operating air flow and motor speed. Maximum operating current and detailed information about sound power are also reported below for each model.

Quick selection item

MAC MODEL	Range	Available static pressure range	Absorbed electrical power range
1	600 - 1400 m ³ h	85 - 160 Pa	75 - 240 W
2	1000 - 2100 m ³ h	65 - 195 Pa	135 - 375 W
3	1500 - 3000 m ³ h	100 - 190 Pa	250 - 520 W
4	2400 - 4500 m ³ h	100 - 280 Pa	600 - 1100 W

MAC MODEL	Maximum fan efficiency	Maximum absorbed current	Radiated sound power range
1	27%	2,2 A	60 - 71 dB(A)
2	30%	2,4 A	56 - 72 dB(A)
3	30%	2,7 A	60 - 74 dB(A)
4	35%	4,8 A	62 - 81 dB(A)

Noise level

Here below the maximum sound power detected for each model (the values are determined with open outlet)

Model	MAC 1			MAC 2			MAC 3			MAC 4		
Speed	3	2	1	3	2	1	3	2	1	3	2	1
Maximum air flow rate (m ³ /h)	1850	1550	1250	2640	1690	1220	3203	2300	1755	5000	4050	2670
Maximum sound pressure db(A)	70	65	60	71	62	56	73	67	60	80	73	62

Size 1

Flow rate / Available static pressure

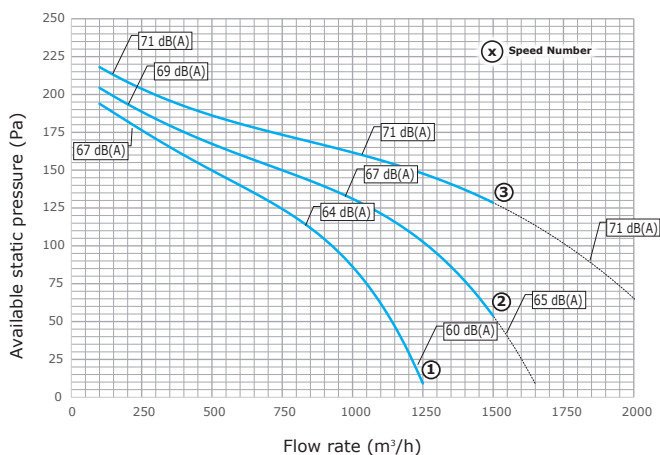

Absorbed electrical power

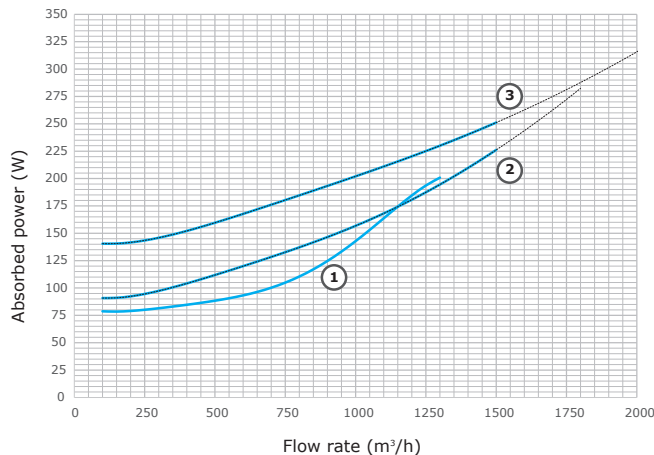

Typical operative sector

Air flow rate: 600 – 1400 m³/h
 Available static pressure: 85 – 160 Pa
 Sound power: 60 – 70 dB(A)
 Power supply: 75 – 240 W
 Maximum current input: 2,2 A

Size 2

Flow rate / Available static pressure

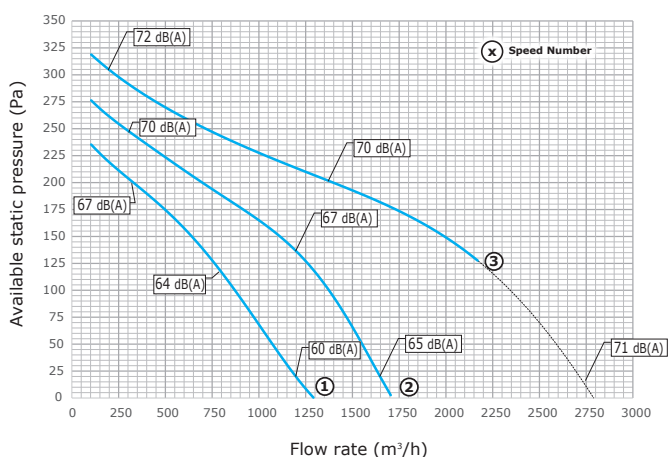

Absorbed electrical power

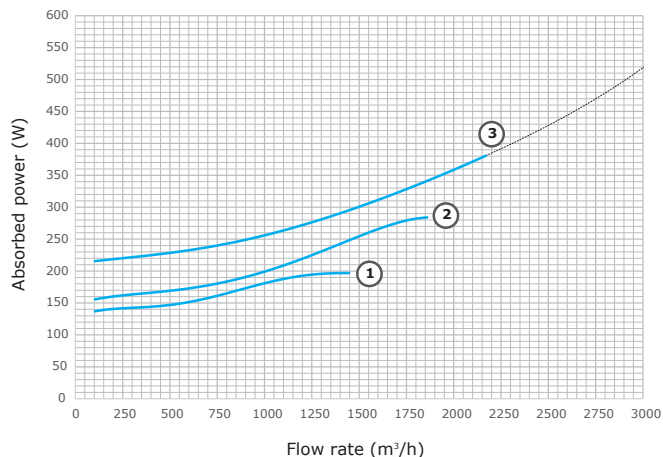

Typical operative sector

Air flow rate: 1000 – 2100 m³/h
 Available static pressure: 65 - 195 Pa
 Sound power: 58 - 70 dB(A)
 Power supply: 135 - 375 W
 Maximum current input: 2,4 A

Size 3

Flow rate / Available static pressure

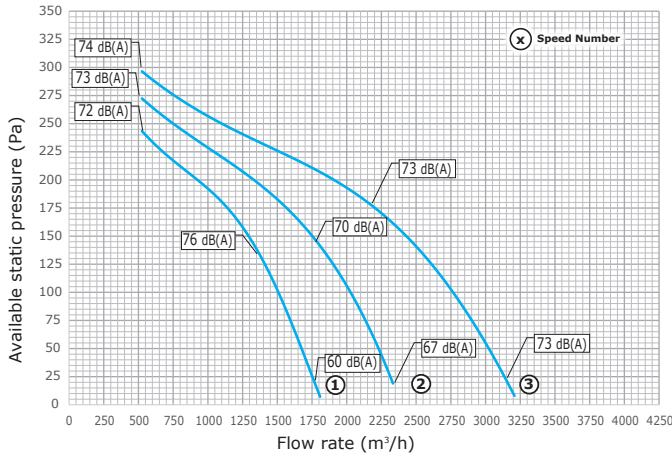

Absorbed electrical power

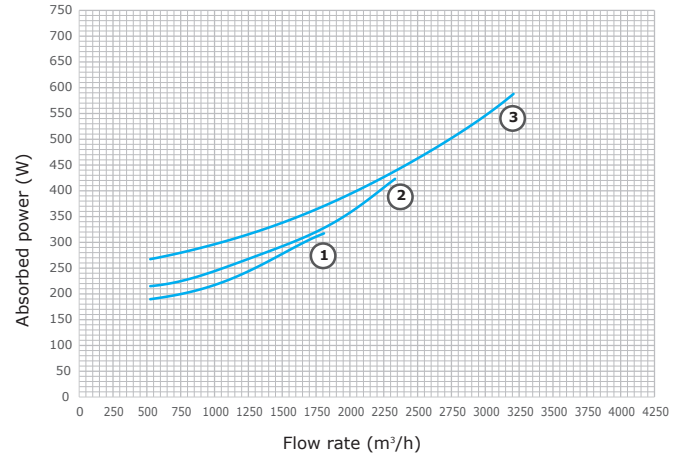

Typical operative sector

Air flow rate: 1500 – 3000 m³/h
 Available static pressure: 100 - 190 Pa
 Sound power: 60 - 80 dB(A)
 Power supply: 250 - 520 W
 Maximum current input: 2,7 A

Size 4

Flow rate / Available static pressure

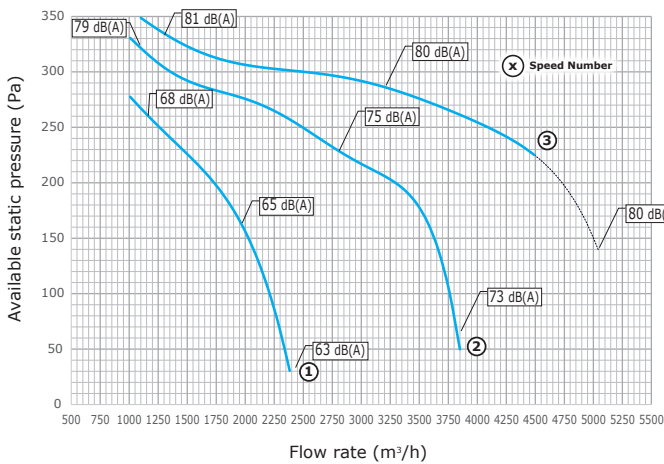

Absorbed electrical power

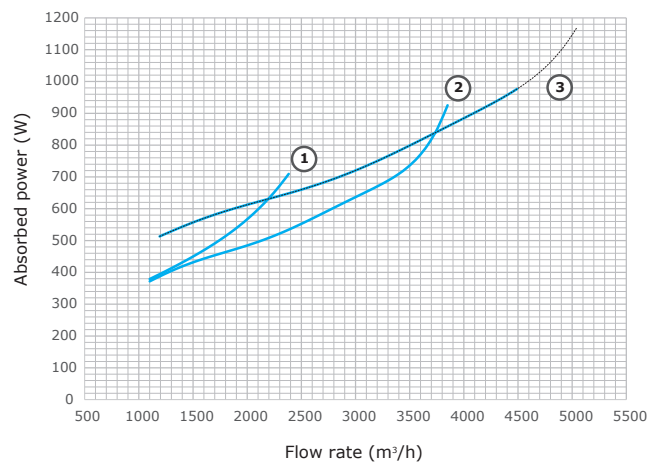

Typical operative sector

Air flow rate: 2400 – 4500 m³/h
 Available static pressure: 100 - 280 Pa
 Sound power: 63 - 81 dB(A)
 Power supply: 600 - 1100 W
 Maximum current input: 4,8 A

MAC-ECM airflow performance

Selection diagrams of SVE-ECM fan section with EC Brushless Electronic Motor and Inverter Board.

The Fan Section is assembled with filtering and air handling sections. The typical curves for unit selection are provided below. Performance curves show fan section typical field of operation, in terms of air flow at specific external static pressures and motor speed.

Absorbed electrical power curves are also provided to the operating air flow and motor speed.

Maximum operating current and detailed information about sound power are also reported below for each model.

Quick selection item

MAC-ECM MODEL	Range	Available static pressure range	Absorbed electrical power range
1	600 - 1400 m ³ h	40 - 160 Pa	15 - 200 W
2	1000 - 2100 m ³ h	40 - 200 Pa	25 - 370 W
3	1500 - 3000 m ³ h	40 - 250 Pa	30 - 600 W
4	2400 - 4500 m ³ h	30 - 270 Pa	30 - 950 W

MAC-ECM MODEL	Maximum fan efficiency	Maximum absorbed current	Radiated sound power range
1	42%	1,9 A	45 - 70 dB(A)
2	36%	3,0 A	50 - 72 dB(A)
3	40%	4,4 A	50 - 82 dB(A)
4	44%	5,0 A	60 - 82 dB(A)

Noise level

Here below the typical sound power emission of the MAC units mod. 1, 2, 3 and 4, related to the reference condition for flow rate regarding the noise tests. When the load points change, it is possible to apply the curve of correction represented in the bottom page, in order to assess the contingent sound power.

		SPEED									
		10	9	8	7	6	5	4	3	2	1
		SIZE 1									
Q_{rif} [m ³ /h]		1980	1920	1790	1660	1530	1400	1270	1140	1020	900
$L_{w rif}$ [dBA]		70,2	69,1	67,1	65,3	63,3	61,2	58,8	56,3	53,3	49,9
		SIZE 2									
Q_{rif} [m ³ /h]		2600	2590	2580	2580	2480	2290	2080	1860	1650	1450
$L_{w rif}$ [dBA]		71,7	71,7	71,7	71,6	71,1	70,1	67,7	65,3	62,4	59,3
		SIZE 3									
Q_{rif} [m ³ /h]		4280	4280	3830	3380	3000	2550	2180	1730	1350	900
$L_{w rif}$ [dBA]		81,7	81,7	79,5	77,0	74,6	71,9	69,0	65,0	60,8	55,4
		SIZE 4									
Q_{rif} [m ³ /h]		5200	5200	5200	5200	5200	5200	4600	3930	3230	2600
$L_{w rif}$ [dBA]		82,4	82,4	82,4	82,4	82,4	82,4	79,0	75,8	73,2	66,8

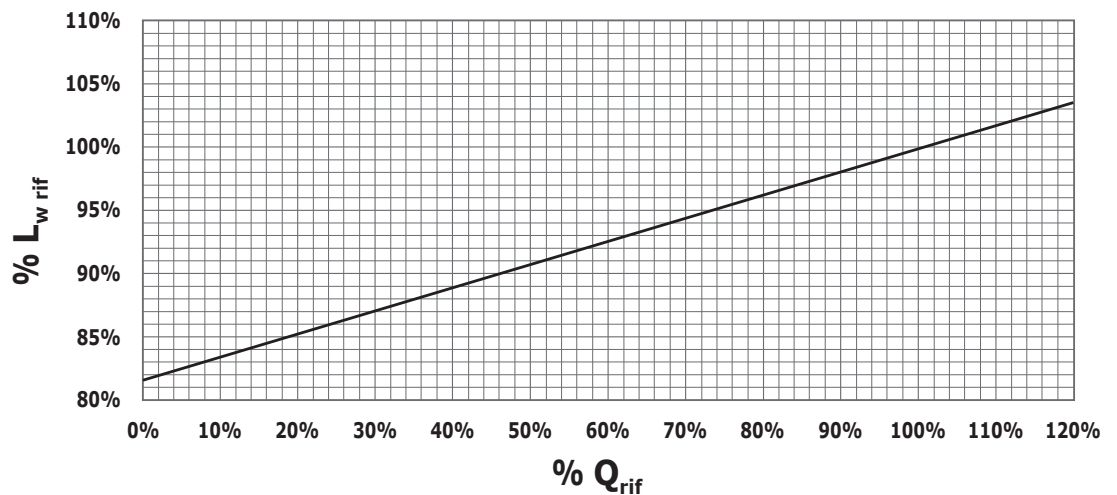

LEGEND

$L_{w rif}$ = Reference sound power

Q_{rif} = Reference flow rate for the noise test

Size 1

Flow rate / Available static pressure

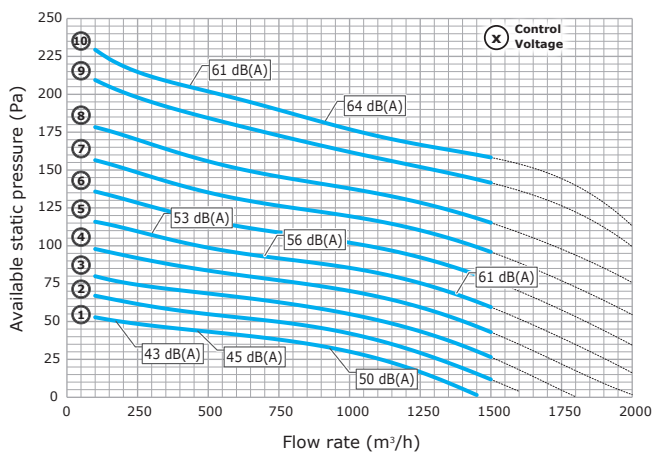

Absorbed electrical power

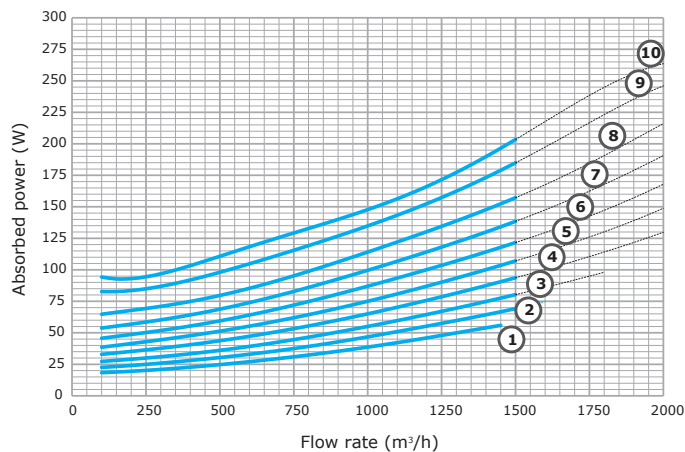

Typical operative sector

Air flow rate: 600 – 1400 m³/h
 Available static pressure: 40 – 160 Pa
 Sound power: 45 – 70 dB(A)
 Power supply: 15 – 200 W
 Maximum current input: 1,9 A

Size 2

Flow rate / Available static pressure

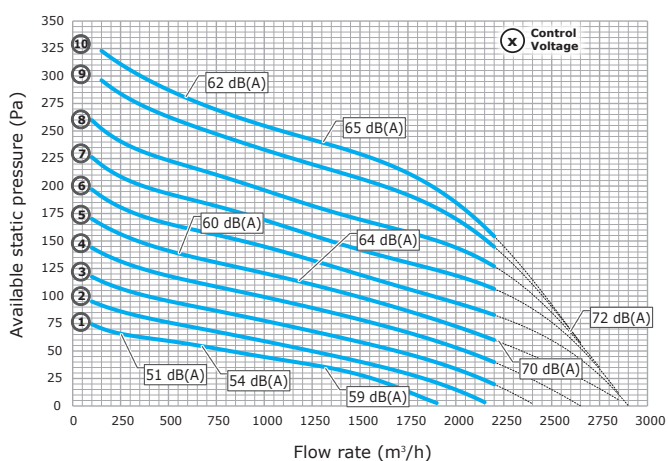

Absorbed electrical power

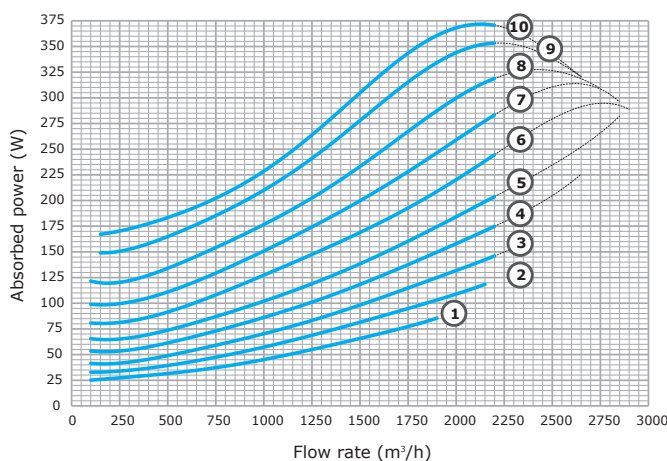

Typical operative sector

Air flow rate: 1000 – 2100 m³/h
 Available static pressure: 40 – 200 Pa
 Sound power: 50 – 72 dB(A)
 Power supply: 25 – 370 W
 Maximum current input: 3,0 A

Size 3

Flow rate / Available static pressure

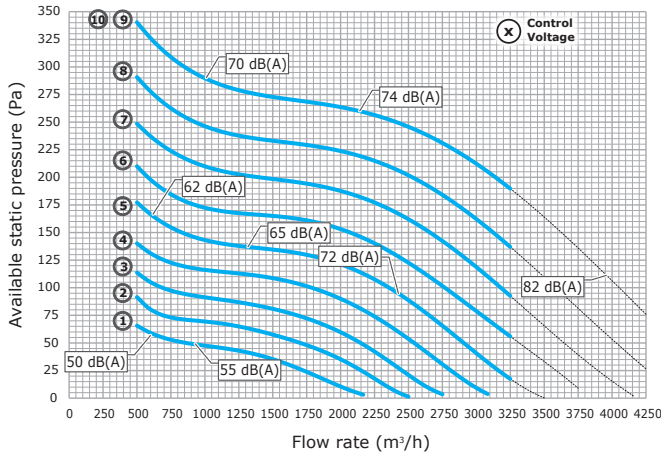

Absorbed electrical power

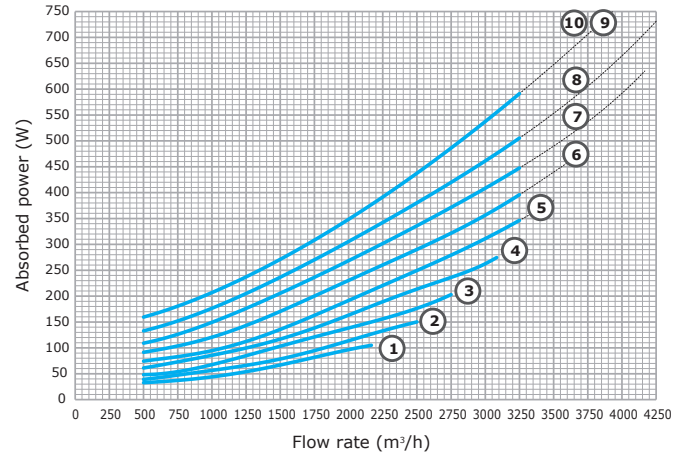

Typical operative sector

- Air flow rate: 1500 – 3000 m³/h
- Available static pressure: 40 – 250 Pa
- Sound power: 50 – 82 dB(A)
- Power supply: 30 – 600 W
- Maximum current input: 4,4 A

Size 4

Flow rate / Available static pressure

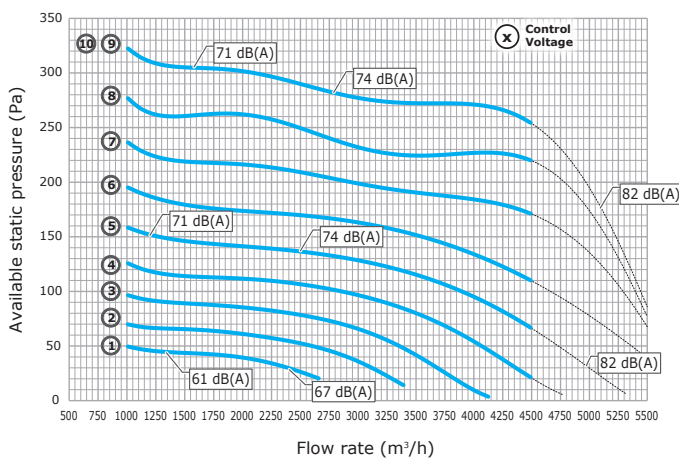

Absorbed electrical power

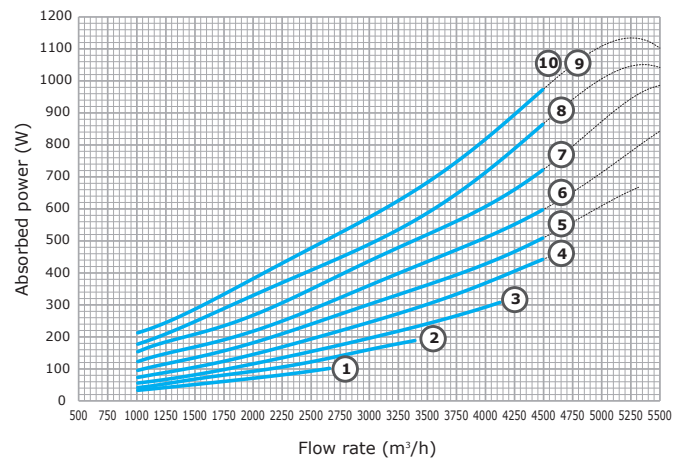

Typical operative sector

- Air flow rate: 2400 – 4500 m³/h
- Available static pressure: 30 – 270 Pa
- Sound power: 60 – 82 dB(A)
- Power supply: 30 – 950 W
- Maximum current input: 5,0 A

Size 1

Cooling coil

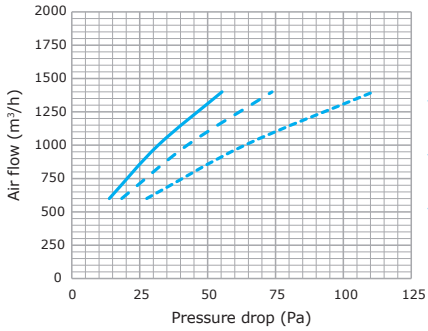

Heating coil

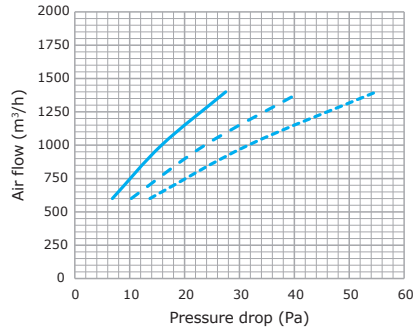

Optional sections

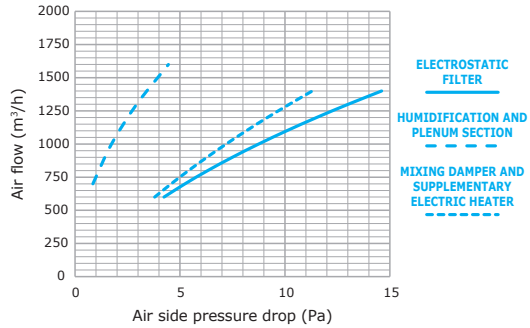
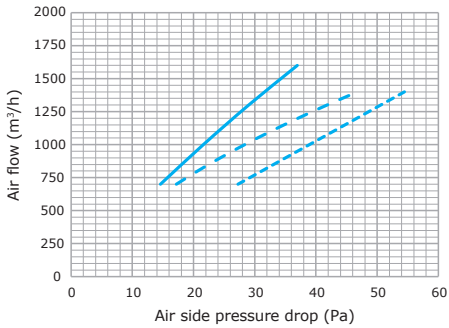

Size 2

Cooling coil

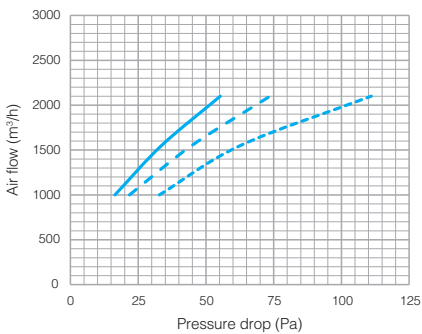

Heating coil

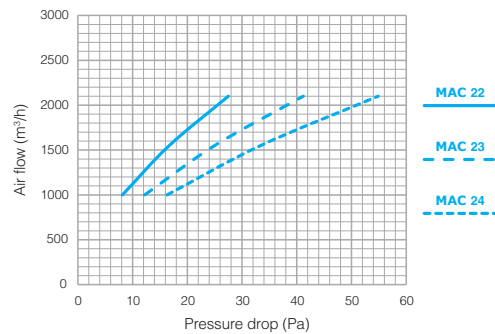

Optional sections

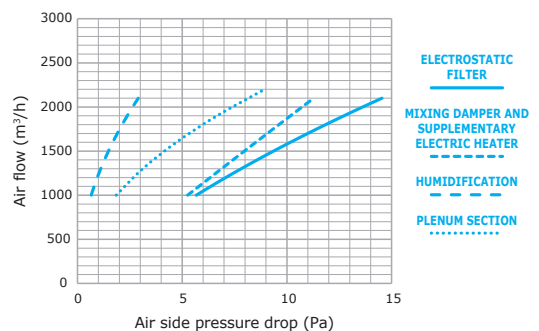
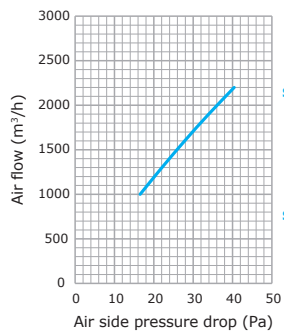
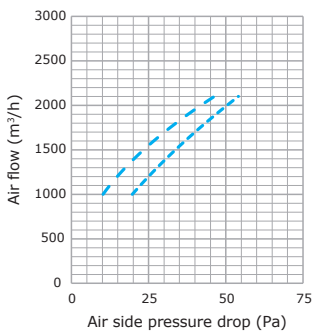

Size 3

Cooling coil

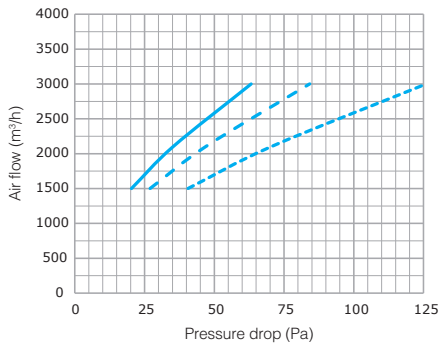

Heating coil

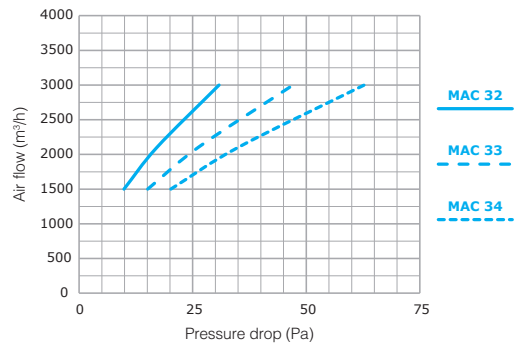

Optional sections

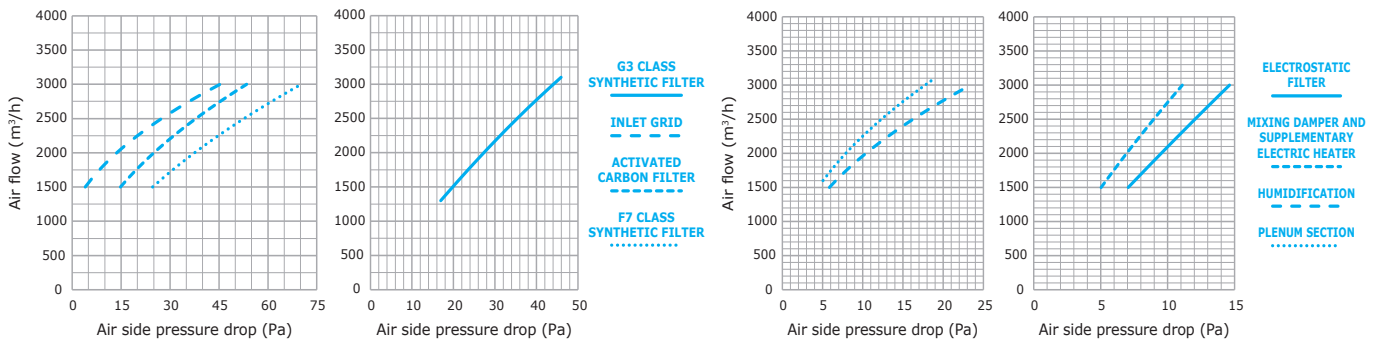

Size 4

Cooling coil

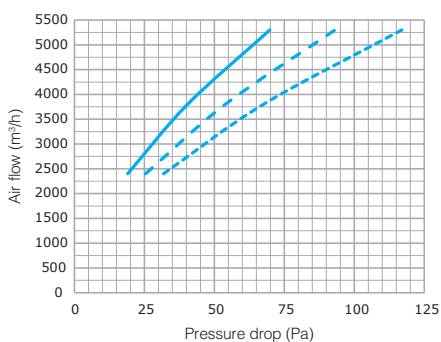

Heating coil

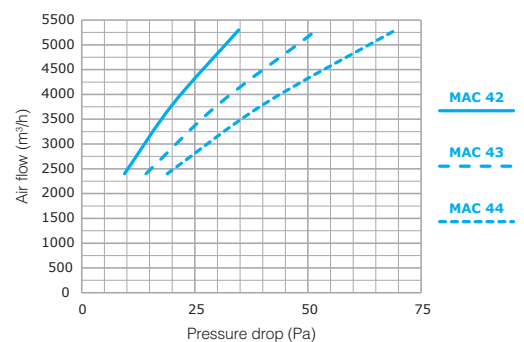

Optional sections

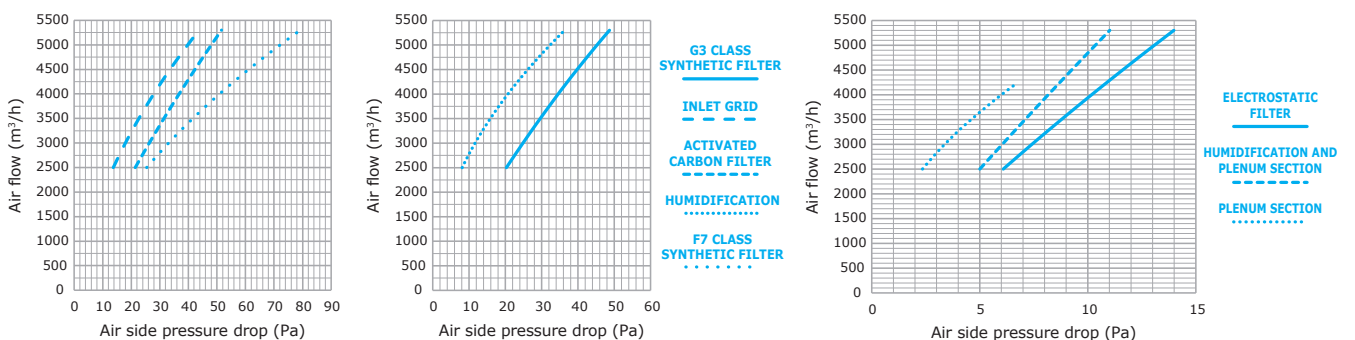

Performance data

Heating emission of MAC Size 1 units

Entering air temperature: 5°C

Model	Qv m³/h	WT: 40/35°C			WT: 45/40°C			WT: 50/40°C			WT: 55/45°C			WT: 60/50°C			WT: 70/60°C		
		Ph kW	Qw l/h	Dp(c) kPa	Ph kW	Qw l/h	Dp(c) kPa	Ph kW	Qw l/h	Dp(c) kPa	Ph kW	Qw l/h	Dp(c) kPa	Ph kW	Qw l/h	Dp(c) kPa	Ph kW	Qw l/h	Dp(c) kPa
MAC 12	600	4,18	718,2	14,07	4,86	836,5	18,16	4,75	408,7	5,60	5,19	446,1	6,92	6,43	552,5	8,22	7,81	671,5	11,30
	800	5,08	874,3	20,04	5,92	1018,2	25,87	5,74	493,5	7,86	6,27	538,8	9,72	7,81	671,9	11,70	9,51	818,0	16,11
	1000	5,88	1011,7	26,06	6,86	1180,0	33,73	6,63	570,1	10,19	7,20	619,3	12,49	9,04	776,9	15,19	11,02	947,1	20,98
	1200	6,60	1135,3	32,08	7,70	1324,6	41,53	7,45	640,7	12,57	8,05	692,3	15,27	10,13	871,4	18,68	12,37	1063,5	25,84
	1400	7,25	1247,3	37,99	8,47	1457,1	49,31	8,21	706,3	14,98	8,81	757,7	17,96	11,13	957,1	22,11	13,60	1169,0	30,64
MAC 13	600	5,22	898,0	10,14	6,07	1043,4	13,03	6,02	517,9	4,13	6,58	565,6	5,11	8,06	693,3	5,97	9,77	839,7	8,14
	800	6,47	1113,2	14,92	7,53	1294,1	19,20	7,41	637,0	6,00	8,08	694,7	7,40	9,98	858,3	8,76	12,12	1042,2	12,01
	1000	7,60	1307,3	19,93	8,84	1520,2	25,65	8,64	742,7	7,90	9,42	810,3	9,77	11,70	1005,9	11,66	14,23	1223,5	16,03
	1200	8,63	1483,7	25,03	10,04	1727,1	32,27	9,77	839,8	9,86	10,62	913,5	12,12	13,27	1141,3	14,63	16,16	1389,4	20,15
	1400	9,57	1645,1	30,14	11,16	1918,4	38,99	10,85	933,0	11,92	11,74	1009,6	14,51	14,73	1266,2	17,64	17,92	1541,1	24,29
MAC 14	600	5,90	1015,4	7,54	6,85	1177,6	9,65	6,90	593,4	3,14	7,54	648,6	3,90	9,15	786,5	4,46	*	*	*
	800	7,43	1278,1	11,40	8,63	1483,5	14,63	8,60	739,7	4,68	9,39	807,7	5,79	11,49	987,9	6,72	13,90	1195,3	9,16
	1000	8,82	1517,5	15,53	10,25	1762,8	19,95	10,14	871,8	6,28	11,07	951,6	7,77	13,62	1171,1	9,13	16,51	1419,7	12,48
	1200	10,11	1738,5	19,84	11,75	2021,1	25,52	11,55	993,2	7,95	12,60	1083,0	9,81	15,59	1340,5	11,64	18,92	1627,1	15,96
	1400	11,30	1943,8	24,25	13,15	2261,5	31,24	12,86	1105,3	9,63	14,01	1204,2	11,88	17,42	1497,5	14,21	21,15	1818,5	19,49

Entering air temperature: 10°C

Model	Qv m³/h	WT: 40/35°C			WT: 45/40°C			WT: 50/40°C			WT: 55/45°C			WT: 60/50°C			WT: 70/60°C		
		Ph kW	Qw l/h	Dp(c) kPa	Ph kW	Qw l/h	Dp(c) kPa	Ph kW	Qw l/h	Dp(c) kPa	Ph kW	Qw l/h	Dp(c) kPa	Ph kW	Qw l/h	Dp(c) kPa	Ph kW	Qw l/h	Dp(c) kPa
MAC 12	600	3,46	595,2	10,03	4,14	711,6	13,57	3,92	337,2	4,45	4,26	366,0	5,40	5,69	489,0	6,60	7,06	606,79	9,41
	800	4,21	723,5	14,26	5,04	867,0	19,37	4,72	406,2	6,22	5,11	439,6	7,52	6,90	593,6	9,36	8,59	738,2	13,39
	1000	4,87	837,8	18,56	5,84	1004,0	25,22	5,43	466,8	7,99	5,87	504,8	9,64	7,98	686,5	12,16	9,94	854,4	17,43
	1200	5,47	940,1	22,84	6,55	1126,3	31,02	6,06	520,9	9,74	6,54	562,3	11,71	8,96	770,3	14,96	11,15	959,1	21,45
	1400	6,01	1033,0	27,06	7,21	1239,6	36,86	6,63	570,1	11,45	7,15	614,7	13,75	9,85	846,6	17,73	12,27	1055,1	25,48
MAC 13	600	4,34	745,6	7,25	5,17	888,9	9,76	4,99	429,1	3,31	5,43	466,9	4,04	7,14	613,9	4,79	8,82	758,2	6,77
	800	5,37	924,0	10,67	6,41	1102,5	14,39	6,12	526,3	4,78	6,64	571,0	5,80	8,83	759,5	7,03	10,94	940,8	9,99
	1000	6,30	1083,2	14,21	7,53	1294,4	19,20	7,12	612,3	6,28	7,71	662,5	7,58	10,35	890,2	9,36	12,84	1104,2	13,33
	1200	7,14	1228,3	17,81	8,55	1469,8	24,14	8,02	689,9	7,78	8,68	746,1	9,39	11,74	1009,5	11,73	14,58	1253,5	16,74
	1400	7,93	1363,1	21,49	9,49	1631,8	29,14	8,85	760,7	9,28	9,56	821,7	11,17	13,01	1118,5	14,11	16,18	1391,3	20,20
MAC 14	600	4,91	845,0	5,41	5,84	1003,6	7,24	5,74	493,9	2,54	6,27	538,7	3,11	8,10	696,7	3,59	*	*	*
	800	6,17	1061,4	8,16	7,35	1264,5	10,97	7,13	613,2	3,75	7,75	666,7	4,57	10,18	875,2	5,41	*	*	*
	1000	7,33	1260,2	11,11	8,73	1501,9	14,95	8,38	720,9	5,02	9,10	782,1	6,09	12,06	1037,0	7,34	14,90	1281,2	10,38
	1200	8,39	1442,8	14,18	10,01	1721,3	19,11	9,54	820,2	6,33	10,33	888,1	7,66	13,80	1186,6	9,35	17,07	1468,0	13,26
	1400	9,37	1612,1	17,32	11,20	1926,6	23,41	10,60	911,2	7,65	11,45	984,6	9,22	15,41	1325,0	11,40	19,11	1642,8	16,23

LEGEND

WT = Water temperature

Ph = Emission

Qw = Water flow

Dp(c) = Water pressure drop

Qv = Air flow

* Operating points outside the range of application of the electric motor

Performance data

Heating emission of MAC Size 1 units

Entering air temperature: 15°C

Model	WT: 40/35°C			WT: 45/40°C			WT: 50/40°C			WT: 55/45°C			WT: 60/50°C			WT: 70/60°C			
	Qv m³/h	Ph kW	Qw l/h	Dp(c) kPa	Ph kW	Qw l/h	Dp(c) kPa	Ph kW	Qw l/h	Dp(c) kPa	Ph kW	Qw l/h	Dp(c) kPa	Ph kW	Qw l/h	Dp(c) kPa	Ph kW	Qw l/h	Dp(c) kPa
MAC 12	600	2,77	475,8	6,70	3,43	590,6	9,70	3,09	265,8	3,30	3,32	285,2	3,88	4,96	426,7	5,16	6,31	542,8	7,70
	800	3,36	577,5	9,50	4,18	718,5	13,81	3,71	319,1	4,58	3,96	340,8	5,35	6,02	517,7	7,32	7,68	660,5	10,97
	1000	3,88	667,4	12,33	4,84	831,9	17,98	4,25	365,7	5,85	4,52	388,7	6,78	6,96	598,7	9,50	8,89	764,1	14,25
	1200	4,36	749,2	15,18	5,43	934,1	22,15	4,73	406,9	7,09	5,02	431,3	8,18	7,81	671,2	11,67	9,98	858,2	17,57
	1400	4,79	823,8	18,01	5,97	1027,2	26,28	5,17	444,5	8,31	5,47	470,2	9,55	8,58	737,8	13,84	10,98	943,8	20,84
MAC 13	600	3,48	597,6	4,87	4,30	738,9	7,00	3,97	341,2	2,49	4,27	367,2	2,95	6,24	536,3	3,76	7,90	679,2	5,56
	800	4,30	739,4	7,15	5,32	915,5	10,30	4,83	415,5	3,55	5,18	445,5	4,18	7,72	663,4	5,51	9,78	841,1	8,17
	1000	5,03	865,4	9,49	6,25	1074,7	13,74	5,61	482,2	4,64	5,98	514,4	5,41	9,03	776,3	7,31	11,49	988,3	10,92
	1200	5,71	981,7	11,90	7,09	1219,4	17,25	6,30	541,3	5,71	6,70	575,9	6,63	10,24	880,4	9,17	13,04	1121,5	13,71
	1400	6,33	1088,0	14,32	7,87	1352,7	20,79	6,94	596,4	6,80	7,35	631,7	7,84	11,36	976,5	11,05	14,47	1244,4	16,53
MAC 14	600	3,95	678,6	3,65	4,86	836,0	5,21	4,59	394,8	1,93	4,96	426,4	2,30	7,09	609,6	2,82	*	*	*
	800	4,95	851,9	5,49	6,11	1051,3	7,87	5,67	487,9	2,82	6,10	524,5	3,34	8,89	764,7	4,24	*	*	*
	1000	5,87	1009,0	7,45	7,26	1247,8	10,71	6,64	570,6	3,74	7,10	610,8	4,39	10,53	905,5	5,75	13,35	1147,8	8,51
	1200	6,71	1153,9	9,48	8,32	1430,2	13,69	7,52	646,2	4,68	8,03	690,3	5,48	12,05	1036,2	7,33	15,29	1314,8	10,87
	1400	7,49	1288,0	11,56	9,30	1598,6	16,73	8,33	715,9	5,63	8,86	761,9	6,54	13,46	1157,4	8,94	17,09	1469,8	13,29

Entering air temperature: 20°C

Model	WT: 40/35°C			WT: 45/40°C			WT: 50/40°C			WT: 55/45°C			WT: 60/50°C			WT: 70/60°C			
	Qv m³/h	Ph kW	Qw l/h	Dp(c) kPa	Ph kW	Qw l/h	Dp(c) kPa	Ph kW	Qw l/h	Dp(c) kPa	Ph kW	Qw l/h	Dp(c) kPa	Ph kW	Qw l/h	Dp(c) kPa	Ph kW	Qw l/h	Dp(c) kPa
MAC 12	600	2,09	358,9	4,04	2,75	472,3	6,49	2,92	250,6	2,06	3,59	308,4	2,93	4,25	365,7	3,91	5,59	480,8	6,19
	800	2,53	435,2	5,71	3,34	574,4	9,23	3,52	302,7	2,89	4,35	373,7	4,14	5,17	444,2	5,55	6,80	584,6	8,80
	1000	2,92	502,2	7,39	3,86	664,5	12,00	4,06	348,7	3,72	5,01	430,6	5,34	5,97	512,9	7,20	7,87	676,5	11,45
	1200	3,27	562,7	9,07	4,33	744,9	14,74	4,54	390,0	4,56	5,61	482,3	6,56	6,69	574,9	8,83	8,84	760,1	14,12
	1400	3,59	617,8	10,73	4,77	819,6	17,51	4,97	427,2	5,37	6,16	529,5	7,76	7,35	632,0	10,48	9,72	835,4	16,74
MAC 13	600	2,63	453,0	2,96	3,45	592,5	4,70	3,71	318,9	1,53	4,53	389,9	2,15	5,36	460,8	2,86	7,00	601,8	4,47
	800	3,25	558,9	4,32	4,27	733,6	6,91	4,56	391,7	2,21	5,59	480,7	3,14	6,62	569,3	4,18	8,67	745,4	6,57
	1000	3,80	653,5	5,72	5,00	859,1	9,18	5,31	456,7	2,92	6,54	561,9	4,16	7,75	666,4	5,56	10,17	874,7	8,76
	1200	4,30	739,4	7,15	5,67	975,1	11,53	6,00	516,0	3,63	7,39	635,2	5,19	8,78	755,0	6,95	11,55	992,9	11,01
	1400	4,77	820,0	8,61	6,29	1082,3	13,92	6,63	570,0	4,35	8,18	703,7	6,24	9,73	836,6	8,37	12,82	1102,1	13,28
MAC 14	600	3,00	516,7	2,23	3,91	672,1	3,52	4,26	366,7	1,17	5,19	446,2	1,64	6,10	524,8	2,15	*	*	*
	800	3,76	646,4	3,34	4,91	844,2	5,30	5,31	456,4	1,74	6,48	557,3	2,44	7,64	657,3	3,23	*	*	*
	1000	4,44	764,1	4,52	5,82	1000,2	7,19	6,25	537,5	2,33	7,66	658,2	3,29	9,05	778,2	4,38	*	*	*
	1200	5,08	872,8	5,74	6,65	1144,4	9,17	7,12	612,5	2,95	8,74	751,3	4,18	10,35	889,8	5,57	13,55	1164,7	8,74
	1400	5,66	973,3	6,98	7,44	1279,8	11,21	7,92	681,4	3,57	9,74	837,8	5,09	11,54	992,3	6,78	15,14	1301,5	10,68

LEGEND

WT = Water temperature

Ph = Emission

Qw = Water flow

Dp(c) = Water pressure drop

Qv = Air flow

* Operating points outside the range of application of the electric motor

Performance data

Heating emission of MAC Size 2 units

Entering air temperature: 5°C

Model	WT: 40/35°C				WT: 45/40°C				WT: 50/40°C				WT: 55/45°C				WT: 60/50°C				WT: 70/60°C			
	Qv m ³ /h	Ph kW	Qw l/h	Dp(c) kPa	Ph kW	Qw l/h	Dp(c) kPa	Ph kW	Qw l/h	Dp(c) kPa	Ph kW	Qw l/h	Dp(c) kPa	Ph kW	Qw l/h	Dp(c) kPa	Ph kW	Qw l/h	Dp(c) kPa	Ph kW	Qw l/h	Dp(c) kPa		
MAC 22	1000	6,74	1158,4	16,03	7,84	1348,9	20,68	7,64	657,0	6,34	8,34	717,4	7,85	10,37	891,4	9,38	12,61	1084,4	12,90					
	1275	7,93	1364,2	21,52	9,24	1589,4	27,79	8,95	769,5	8,42	9,77	839,8	10,42	12,20	1048,9	12,57	14,85	1276,6	17,30					
	1550	9,01	1548,7	27,04	10,51	1806,8	35,01	10,16	873,2	10,58	11,03	948,4	12,97	13,83	1189,0	15,75	16,87	1450,1	21,76					
	1825	9,99	1717,1	32,56	11,66	2005,8	42,25	11,28	969,5	12,77	12,18	1047,4	15,51	15,34	1319,3	18,99	18,71	1608,6	26,23					
	2100	10,88	1870,9	37,99	12,71	2185,7	49,31	12,32	1059,4	14,98	13,22	1136,5	17,96	16,70	1435,7	22,11	20,39	1753,5	30,64					
MAC 23	1000	8,49	1459,2	11,71	9,86	1696,2	15,06	9,76	839,0	4,75	10,65	915,9	5,87	13,09	1125,3	6,87	15,87	1364,6	9,40					
	1275	10,15	1745,0	16,15	11,80	2029,2	20,79	11,59	996,4	6,47	12,64	1087,2	7,99	15,64	1345,0	9,48	18,99	1632,7	12,99					
	1550	11,66	2005,3	20,75	13,57	2334,1	26,75	13,24	1138,7	8,22	14,45	1242,2	10,16	17,96	1543,9	12,15	21,83	1877,0	16,69					
	1825	13,06	2245,1	25,43	15,22	2618,0	32,89	14,80	1272,4	10,04	16,10	1383,9	12,34	20,10	1728,2	14,88	24,45	2102,4	20,47					
	2100	14,35	2467,6	30,14	16,73	2877,6	38,99	16,28	1399,4	11,92	17,61	1514,4	14,51	22,09	1899,3	17,64	26,89	2311,6	24,28					
MAC 24	1000	9,65	1659,0	8,79	11,19	1924,6	11,26	11,23	965,5	3,64	12,28	1055,7	4,52	14,93	1283,9	5,19	*	*	*					
	1275	11,68	2009,1	12,40	13,56	2332,5	15,92	13,49	1160,2	5,07	14,74	1267,3	6,27	18,07	1553,6	7,32	21,87	1880,4	9,98					
	1550	13,57	2332,8	16,23	15,76	2710,3	20,86	15,58	1339,9	6,57	16,99	1461,1	8,11	20,93	1799,9	9,54	25,39	2182,6	13,05					
	1825	15,31	2632,6	20,18	17,81	3063,0	25,99	17,50	1504,4	8,09	19,06	1638,9	9,97	23,64	2032,7	11,87	28,68	2465,7	16,25					
	2100	16,96	2915,7	24,25	19,73	3392,1	31,24	19,28	1658,0	9,63	21,01	1806,3	11,88	26,12	2246,2	14,21	31,72	2727,7	19,49					

Entering air temperature: 10°C

Model	WT: 40/35°C				WT: 45/40°C				WT: 50/40°C				WT: 55/45°C				WT: 60/50°C				WT: 70/60°C			
	Qv m ³ /h	Ph kW	Qw l/h	Dp(c) kPa	Ph kW	Qw l/h	Dp(c) kPa	Ph kW	Qw l/h	Dp(c) kPa	Ph kW	Qw l/h	Dp(c) kPa	Ph kW	Qw l/h	Dp(c) kPa	Ph kW	Qw l/h	Dp(c) kPa	Ph kW	Qw l/h	Dp(c) kPa		
MAC 22	1000	5,59	960,5	11,44	6,68	1149,2	15,50	6,31	542,2	5,04	6,83	587,6	6,11	9,17	788,7	7,52	11,37	978,0	10,71					
	1275	6,58	1130,8	15,35	7,87	1353,1	20,80	7,36	633,2	6,67	7,97	685,5	8,06	10,79	927,4	10,07	13,41	1153,1	14,41					
	1550	7,46	1282,3	19,25	8,94	1537,2	26,17	8,31	714,5	8,29	8,98	772,2	9,99	12,23	1051,6	12,63	15,23	1309,4	18,11					
	1825	8,27	1421,8	23,18	9,92	1705,4	31,55	9,16	787,9	9,89	9,89	850,4	11,88	13,55	1164,8	15,18	16,89	1452,2	21,82					
	2100	9,01	1549,5	27,06	10,81	1859,3	36,86	9,95	855,1	11,45	10,72	922,0	13,74	14,77	1269,8	17,73	18,41	1582,7	25,48					
MAC 23	1000	7,04	1211,1	8,37	8,40	1443,6	11,27	8,07	694,1	3,79	8,78	754,5	4,62	11,59	996,1	5,52	14,33	1232,1	7,82					
	1275	8,42	1448,1	11,55	10,05	1728,5	15,58	9,56	822,4	5,15	10,37	891,6	6,24	13,84	1190,0	7,60	17,14	1473,8	10,80					
	1550	9,67	1662,6	14,81	11,56	1987,3	20,03	10,91	938,2	6,52	11,81	1015,7	7,89	15,88	1365,1	9,73	19,72	1695,2	13,90					
	1825	10,83	1861,6	18,15	12,96	2227,8	24,60	12,15	1044,9	7,92	13,13	1128,7	9,53	17,76	1527,3	11,91	22,06	1896,8	17,01					
	2100	11,89	2044,6	21,49	14,23	2447,6	29,14	13,27	1141,0	9,28	14,34	1232,5	11,17	19,51	1677,8	14,11	24,27	2086,9	20,20					
MAC 24	1000	8,02	1379,4	6,30	9,54	1639,9	8,44	9,34	802,7	2,94	10,17	874,2	3,59	13,22	1137,1	4,17	*	*	*					
	1275	9,71	1669,3	8,89	11,57	1989,3	11,95	11,19	962,4	4,07	12,16	1045,8	4,95	15,98	1374,3	5,87	19,74	1697,3	8,30					
	1550	11,26	1937,0	11,61	13,44	2310,5	15,65	12,87	1106,6	5,23	13,96	1200,1	6,34	18,54	1593,8	7,66	22,91	1969,6	10,85					
	1825	12,70	2184,7	14,42	15,17	2608,5	19,47	14,43	1241,1	6,43	15,62	1343,4	7,77	20,91	1797,9	9,52	25,89	2226,2	13,52					
	2100	14,06	2418,2	17,32	16,81	2889,9	23,41	15,90	1366,7	7,65	17,18	1476,9	9,22	23,12	1987,5	11,40	28,66	2464,2	16,23					

LEGEND

WT = Water temperature

Ph = Emission

Qw = Water flow

Dp(c) = Water pressure drop

Qv = Air flow

* Operating points outside the range of application of the electric motor

Performance data

Heating emission of MAC Size 2 units

Entering air temperature: 15°C

Model	WT: 40/35°C				WT: 45/40°C			WT: 50/40°C			WT: 55/45°C			WT: 60/50°C			WT: 70/60°C		
	Qv m³/h	Ph kW	Qw l/h	Dp(c) kPa	Ph kW	Qw l/h	Dp(c) kPa	Ph kW	Qw l/h	Dp(c) kPa	Ph kW	Qw l/h	Dp(c) kPa	Ph kW	Qw l/h	Dp(c) kPa	Ph kW	Qw l/h	Dp(c) kPa
MAC 22	1000	4,46	767,1	7,63	5,54	952,4	11,06	4,97	427,0	3,73	5,31	457,0	4,37	8,00	687,8	5,88	10,18	875,4	8,77
	1275	5,25	902,2	10,22	6,53	1122,1	14,85	5,78	497,0	4,90	6,16	529,9	5,71	9,40	808,6	7,87	11,99	1030,6	11,77
	1550	5,95	1023,3	12,82	7,40	1273,4	18,65	6,50	559,0	6,06	6,91	594,4	7,02	10,67	917,0	9,87	13,62	1170,9	14,81
	1825	6,60	1134,1	15,43	8,22	1412,8	22,48	7,15	615,1	7,19	7,58	651,7	8,29	11,82	1016,0	11,87	15,11	1299,4	17,86
	2100	7,19	1235,7	18,01	8,96	1540,7	26,28	7,75	666,7	8,31	8,20	705,3	9,55	12,87	1106,7	13,84	16,46	1415,6	20,84
MAC 23	1000	5,64	970,2	5,62	6,98	1200,4	8,08	6,40	550,6	2,84	6,88	591,3	3,35	10,13	870,6	4,33	12,83	1102,8	6,41
	1275	6,74	1158,3	7,73	8,35	1435,0	11,14	7,55	649,4	3,82	8,09	695,4	4,49	12,09	1039,2	5,96	15,35	1319,5	8,85
	1550	7,72	1328,1	9,88	9,59	1649,8	14,32	8,58	738,1	4,81	9,15	786,6	5,60	13,87	1192,3	7,63	17,65	1517,2	11,38
	1825	8,64	1485,1	12,08	10,74	1846,6	17,55	9,53	819,6	5,81	10,14	871,7	6,74	15,50	1333,1	9,33	19,75	1698,5	13,94
	2100	9,49	1632,1	14,32	11,80	2029,0	20,79	10,40	894,5	6,80	11,02	947,6	7,84	17,04	1464,8	11,05	21,71	1866,5	16,52
MAC 24	1000	6,44	1107,3	4,24	7,94	1364,9	6,07	7,45	641,0	2,22	8,04	691,2	2,65	11,57	994,6	3,28	*	*	*
	1275	7,78	1337,7	5,96	9,62	1653,5	8,57	8,88	763,4	3,05	9,53	819,8	3,60	13,98	1202,3	4,61	*	*	*
	1550	9,02	1550,6	7,78	11,16	1919,4	11,21	10,19	875,9	3,90	10,90	937,0	4,57	16,20	1392,5	6,01	20,52	1764,3	8,90
	1825	10,17	1748,4	9,66	12,59	2165,6	13,93	11,39	979,1	4,77	12,14	1043,5	5,55	18,26	1570,0	7,46	23,16	1990,9	11,06
	2100	11,23	1931,9	11,56	13,94	2397,9	16,73	12,49	1073,9	5,63	13,29	1142,9	6,54	20,19	1736,0	8,94	25,64	2204,7	13,29

Entering air temperature: 20°C

Model	WT: 40/35°C				WT: 45/40°C			WT: 50/40°C			WT: 55/45°C			WT: 60/50°C			WT: 70/60°C		
	Qv m³/h	Ph kW	Qw l/h	Dp(c) kPa	Ph kW	Qw l/h	Dp(c) kPa	Ph kW	Qw l/h	Dp(c) kPa	Ph kW	Qw l/h	Dp(c) kPa	Ph kW	Qw l/h	Dp(c) kPa	Ph kW	Qw l/h	Dp(c) kPa
MAC 22	1000	3,36	578,4	4,59	4,43	761,8	7,40	4,69	403,3	2,33	5,78	496,7	3,33	6,86	589,7	4,46	9,02	775,2	7,05
	1275	3,95	679,2	6,13	5,21	896,7	9,92	5,49	472,2	3,10	6,78	583,0	4,44	8,06	692,9	5,96	10,62	912,8	9,46
	1550	4,48	769,7	7,68	5,91	1016,8	12,44	6,21	534,0	3,87	7,67	659,7	5,55	9,14	785,4	7,47	12,05	1036,5	11,89
	1825	4,95	851,7	9,22	6,56	1127,7	14,98	6,86	590,1	4,63	8,49	729,9	6,66	10,11	869,2	8,96	13,37	1149,5	14,33
	2100	5,39	926,7	10,73	7,15	1229,4	17,50	7,45	640,8	5,37	9,24	794,3	7,76	11,03	948,0	10,48	14,57	1253,1	16,74
MAC 23	1000	4,27	734,7	3,40	5,60	962,1	5,43	6,01	516,3	1,75	7,35	632,0	2,48	8,69	747,1	3,29	11,36	976,9	5,15
	1275	5,09	874,9	4,66	6,68	1149,4	7,47	7,13	613,0	2,39	8,76	752,9	3,40	10,38	892,2	4,53	13,60	1169,2	7,12
	1550	5,83	1002,4	5,96	7,67	1318,6	9,57	8,15	700,6	3,04	10,02	861,8	4,33	11,89	1022,5	5,79	15,62	1342,6	9,13
	1825	6,52	1120,5	7,28	8,59	1476,5	11,73	9,08	780,9	3,69	11,19	962,4	5,28	13,29	1143,1	7,07	17,49	1503,5	11,20
	2100	7,15	1230,0	8,61	9,44	1623,5	13,92	9,94	855,0	4,35	12,28	1055,5	6,24	14,60	1254,9	8,37	19,23	1653,1	13,2
MAC 24	1000	4,90	841,9	2,59	6,38	1096,9	4,09	6,94	596,3	1,35	8,45	726,8	1,90	9,95	855,5	2,50	*	*	*
	1275	5,91	1015,9	3,63	7,71	1326,5	5,76	8,33	716,1	1,88	10,18	875,1	2,65	12,02	1033,2	3,51	*	*	*
	1550	6,83	1173,8	4,71	8,94	1537,2	7,52	9,60	825,2	2,43	11,77	1011,8	3,44	13,92	1196,5	4,57	18,18	1563,5	7,16
	1825	7,69	1322,3	5,84	10,09	1735,3	9,35	10,78	926,8	2,99	13,23	1137,2	4,25	15,67	1347,0	5,66	20,51	1763,6	8,89
	2100	8,49	1459,9	6,98	11,16	1919,7	11,21	11,89	1022,1	3,57	14,62	1256,7	5,09	17,31	1488,4	6,78	22,71	1952,3	10,68

LEGEND

WT = Water temperature

Ph = Emission

Qw = Water flow

Dp(c) = Water pressure drop

Qv = Air flow

* Operating points outside the range of application of the electric motor

Performance data

Heating emission of MAC Size 3 units

Entering air temperature: 5°C

Model	Qv m ³ /h	WT: 40/35°C			WT: 45/40°C			WT: 50/40°C			WT: 55/45°C			WT: 60/50°C			WT: 70/60°C		
		Ph kW	Qw l/h	Dp(c) kPa	Ph kW	Qw l/h	Dp(c) kPa	Ph kW	Qw l/h	Dp(c) kPa	Ph kW	Qw l/h	Dp(c) kPa	Ph kW	Qw l/h	Dp(c) kPa	Ph kW	Qw l/h	Dp(c) kPa
MAC 32	1500	9,90	1701,7	35,89	11,50	1976,9	46,12	11,51	989,6	14,85	12,55	1079,5	18,34	15,24	1310,1	21,01	18,48	1588,9	28,75
	1800	11,18	1922,1	44,69	13,00	2235,3	57,53	13,00	1117,6	18,48	14,15	1216,4	22,74	17,19	1477,9	26,10	20,86	1793,5	35,75
	2100	12,35	2124,5	53,51	14,37	2470,4	68,87	14,38	1236,5	22,17	15,65	1345,7	27,28	18,99	1633,2	31,25	23,06	1982,9	42,83
	2550	13,97	2401,9	66,74	16,26	2796,6	86,10	16,23	1395,6	27,57	17,73	1524,2	34,13	21,46	1845,5	38,94	26,08	2242,6	53,45
	3000	15,42	2650,9	79,71	17,95	3086,7	102,84	17,93	1541,6	32,97	19,58	1683,9	40,83	23,68	2036,2	46,48	28,80	2476,0	63,88
MAC 33	1500	12,49	2148,2	26,21	14,48	2490,8	33,56	14,59	1254,5	10,93	16,00	1376,1	13,63	19,29	1658,4	15,42	23,30	2003,5	20,95
	1800	14,26	2452,3	33,27	16,56	2847,6	42,71	16,67	1433,2	13,88	18,19	1564,3	17,17	22,00	1891,5	19,54	26,63	2289,3	26,64
	2100	15,91	2736,4	40,52	18,48	3177,3	52,02	18,60	1599,0	16,91	20,23	1739,2	20,78	24,53	2108,9	23,77	29,72	2555,2	32,46
	2550	18,20	3129,1	51,59	21,15	3636,8	66,33	21,27	1829,0	21,54	23,15	1990,5	26,50	28,04	2410,6	30,24	33,99	2922,8	41,35
	3000	20,26	3484,6	62,61	23,57	4053,7	80,65	23,67	2035,3	26,10	25,81	2219,1	32,22	31,22	2683,9	36,69	37,90	3258,9	50,29
MAC 34	1500	14,27	2454,2	19,85	16,53	2842,3	25,36	16,84	1448,2	8,43	18,51	1591,3	10,55	22,10	1900,1	11,74	*	*	*
	1800	16,46	2830,8	25,66	19,07	3280,1	32,82	19,33	1662,0	10,80	21,23	1825,3	13,51	25,46	2188,8	15,14	30,73	2642,5	20,55
	2100	18,51	3182,3	31,68	21,47	3691,9	40,61	21,75	1870,1	13,36	23,75	2042,0	16,53	28,60	2459,2	18,67	34,56	2971,2	25,37
	2550	21,39	3678,5	41,12	24,82	4267,7	52,71	25,12	2160,0	17,31	27,30	2346,9	21,23	33,01	2838,1	24,17	39,96	3435,4	32,95
	3000	24,02	4130,9	50,67	27,89	4796,0	65,03	28,18	2422,7	21,28	30,66	2636,2	26,18	37,04	3184,4	29,74	44,85	3856,1	40,57

Entering air temperature: 10°C

Model	Qv m ³ /h	WT: 40/35°C			WT: 45/40°C			WT: 50/40°C			WT: 55/45°C			WT: 60/50°C			WT: 70/60°C		
		Ph kW	Qw l/h	Dp(c) kPa	Ph kW	Qw l/h	Dp(c) kPa	Ph kW	Qw l/h	Dp(c) kPa	Ph kW	Qw l/h	Dp(c) kPa	Ph kW	Qw l/h	Dp(c) kPa	Ph kW	Qw l/h	Dp(c) kPa
MAC 32	1500	8,23	1414,4	25,73	9,81	1687,0	34,66	9,53	819,4	11,88	10,46	899,1	14,72	13,49	1160,1	16,88	16,70	1435,5	23,94
	1800	9,28	1596,3	31,99	11,08	1904,7	43,13	10,71	921,2	14,67	11,74	1009,2	18,12	15,23	1309,3	20,99	18,86	1621,6	29,82
	2100	10,25	1763,0	38,25	12,25	2106,2	51,69	11,81	1015,9	17,50	12,91	1109,7	21,50	16,82	1446,2	25,10	20,85	1792,5	35,71
	2550	11,59	1993,3	47,71	13,86	2382,9	64,54	13,38	1150,1	21,88	14,50	1246,9	26,52	19,02	1635,0	31,31	23,57	2026,8	44,55
	3000	12,80	2200,5	57,01	15,30	2631,7	77,17	14,78	1270,7	26,18	15,96	1372,3	31,51	20,97	1803,1	37,34	26,02	2237,3	53,23
MAC 33	1500	10,38	1785,1	18,78	12,36	2125,6	25,23	12,19	1048,1	8,89	13,37	1149,6	11,00	17,09	1469,0	12,40	21,07	1811,4	17,48
	1800	11,85	2038,0	23,84	14,12	2427,4	32,04	13,83	1189,4	11,16	15,16	1303,7	13,80	19,49	1676,0	15,72	24,07	2069,6	22,21
	2100	13,23	2274,6	29,05	15,76	2709,6	39,05	15,35	1320,1	13,46	16,82	1446,5	16,63	21,72	1867,9	19,11	26,84	2307,8	27,02
	2550	15,11	2598,9	36,93	18,04	3102,5	49,83	17,47	1501,7	16,98	19,10	1642,5	20,91	24,82	2134,1	24,28	30,72	2641,4	34,46
	3000	16,85	2897,2	44,91	20,10	3456,7	60,54	19,49	1675,6	20,68	21,17	1819,9	25,15	27,65	2377,1	29,49	34,25	2944,5	41,90
MAC 34	1500	11,89	2044,1	14,28	14,11	2426,2	19,07	14,13	1214,6	6,91	15,53	1334,9	8,58	19,59	1684,8	9,45	*	*	*
	1800	13,70	2356,7	18,45	16,28	2799,1	24,67	16,18	1391,3	8,82	17,75	1526,2	10,91	22,57	1940,2	12,19	27,78	2388,2	17,13
	2100	15,40	2648,2	22,76	18,32	3149,7	30,51	18,09	1555,7	10,78	19,84	1706,0	13,34	25,36	2180,8	15,04	31,25	2686,9	21,17
	2550	17,78	3057,0	29,47	21,16	3639,5	39,58	20,76	1784,8	13,80	22,73	1954,2	17,03	29,24	2514,0	19,43	36,07	3101,7	27,42
	3000	19,97	3433,5	36,33	23,79	4091,6	48,86	23,20	1994,6	16,86	25,36	2180,8	20,75	32,82	2821,8	23,92	40,55	3486,1	33,83

LEGEND

WT = Water temperature

Ph = Emission

Qw = Water flow

Dp(c) = Water pressure drop

Qv = Air flow

* Operating points outside the range of application of the electric motor

Performance data

Heating emission of MAC Size 3 units

Entering air temperature: 15°C

Model	WT: 40/35°C			WT: 45/40°C			WT: 50/40°C			WT: 55/45°C			WT: 60/50°C			WT: 70/60°C			
	Qv m³/h	Ph kW	Qw l/h	Dp(c) kPa	Ph kW	Qw l/h	Dp(c) kPa	Ph kW	Qw l/h	Dp(c) kPa	Ph kW	Qw l/h	Dp(c) kPa	Ph kW	Qw l/h	Dp(c) kPa	Ph kW	Qw l/h	Dp(c) kPa
MAC 32	1500	6,59	1132,4	17,24	8,15	1401,5	24,83	7,64	657,0	9,07	8,34	717,3	11,03	11,80	1014,3	13,26	14,96	1285,9	19,64
	1800	7,44	1278,8	21,46	9,20	1582,6	30,90	8,56	736,0	11,13	9,34	802,9	13,52	13,30	1143,9	16,46	16,89	1452,1	24,45
	2100	8,20	1410,5	25,60	10,18	1750,5	37,05	9,41	809,1	13,20	10,24	880,1	15,94	14,70	1264,0	19,70	18,66	1604,6	29,26
	2550	9,28	1595,7	31,97	11,51	1978,5	46,18	10,58	909,5	16,29	11,48	986,7	19,59	16,61	1427,9	24,53	21,12	1815,6	36,55
	3000	10,24	1761,0	38,17	12,71	2185,5	55,24	11,60	997,6	19,24	12,58	1081,6	23,11	18,32	1575,2	29,28	23,33	2005,8	43,72
MAC 33	1500	8,34	1433,8	12,66	10,28	1768,3	18,12	9,81	843,2	6,83	10,73	922,3	8,33	14,94	1284,6	9,74	18,87	1622,2	14,33
	1800	9,51	1635,3	16,04	11,75	2019,7	23,01	11,11	954,8	8,54	12,11	1041,6	10,37	17,05	1465,9	12,35	21,55	1852,8	18,20
	2100	10,60	1823,4	19,52	13,10	2253,2	28,02	12,29	1057,0	10,25	13,40	1152,5	12,44	18,99	1633,0	15,00	24,06	2068,8	22,20
	2550	12,11	2082,4	24,79	14,99	2578,0	35,71	13,94	1198,9	12,86	15,17	1304,4	15,54	21,70	1865,9	19,07	27,51	2365,1	28,25
	3000	13,48	2318,6	30,07	16,71	2872,7	43,39	15,44	1327,6	15,45	16,75	1439,8	18,57	24,16	2077,0	23,13	30,68	2638,1	34,38
MAC 34	1500	9,56	1644,8	9,66	11,76	2021,5	13,73	11,43	982,6	5,36	12,54	1078,1	6,57	17,17	1476,4	7,45	*	*	*
	1800	11,01	1893,6	12,45	13,56	2331,3	17,75	13,05	1122,1	6,80	14,28	1227,6	8,30	19,77	1699,6	9,60	*	*	*
	2100	12,37	2127,8	15,35	15,25	2622,1	21,93	14,55	1251,1	8,27	15,90	1367,1	10,08	22,19	1908,3	11,83	27,99	2406,9	17,37
	2550	14,27	2453,9	19,84	17,61	3028,1	28,42	16,66	1432,1	10,55	18,15	1560,5	12,79	25,59	2200,3	15,29	32,33	2779,8	22,51
	3000	16,01	2753,5	24,42	19,79	3402,3	35,05	18,54	1594,4	12,80	20,19	1736,0	15,49	28,71	2468,4	18,80	36,33	3123,5	27,76

Entering air temperature: 20°C

Model	WT: 40/35°C			WT: 45/40°C			WT: 50/40°C			WT: 55/45°C			WT: 60/50°C			WT: 70/60°C			
	Qv m³/h	Ph kW	Qw l/h	Dp(c) kPa	Ph kW	Qw l/h	Dp(c) kPa	Ph kW	Qw l/h	Dp(c) kPa	Ph kW	Qw l/h	Dp(c) kPa	Ph kW	Qw l/h	Dp(c) kPa	Ph kW	Qw l/h	Dp(c) kPa
MAC 32	1500	4,99	858,3	10,47	6,53	1123,7	16,68	7,00	601,8	5,37	8,57	736,9	7,59	10,14	871,8	10,10	13,25	1139,5	15,80
	1800	5,62	967,0	12,98	7,38	1268,4	20,75	7,88	677,2	6,64	9,65	830,1	9,41	11,44	983,2	12,53	14,97	1287,4	19,68
	2100	6,21	1067,7	15,51	8,15	1401,3	24,82	8,68	746,6	7,92	10,66	916,6	11,25	12,62	1085,5	14,98	16,54	1422,0	23,54
	2550	7,01	1205,8	19,31	9,22	1584,6	30,97	9,78	840,7	9,80	12,02	1033,7	13,96	14,26	1226,0	18,65	18,70	1608,0	29,37
	3000	7,73	1328,9	23,00	10,18	1750,0	37,03	10,76	925,6	11,66	13,25	1139,1	16,63	15,73	1352,6	22,26	20,67	1777,5	35,18
MAC 33	1500	6,34	1090,2	7,73	8,26	1421,0	12,22	8,96	770,1	4,02	10,91	938,4	5,63	12,86	1105,5	7,43	16,74	1439,0	11,55
	1800	7,22	1242,2	9,78	9,44	1622,6	15,52	10,18	875,3	5,06	12,42	1068,3	7,11	14,67	1261,5	9,43	19,11	1642,9	14,66
	2100	8,04	1382,9	11,86	10,52	1808,6	18,87	11,31	972,3	6,12	13,83	1189,3	8,63	16,35	1405,4	11,45	21,33	1833,8	17,87
	2550	9,17	1577,1	15,03	12,02	2066,7	23,98	12,88	1107,3	7,73	15,77	1356,0	10,93	18,64	1603,0	14,51	24,39	2097,3	22,75
	3000	10,21	1755,5	18,23	13,39	2302,3	29,13	14,29	1229,0	9,32	17,54	1507,9	13,23	20,75	1784,3	17,59	27,17	2336,2	27,63
MAC 34	1500	7,30	1255,3	5,94	9,47	1628,4	9,30	10,38	892,6	3,12	12,59	1082,8	4,34	14,79	1271,4	5,70	*	*	*
	1800	8,39	1443,3	7,63	10,91	1876,6	12,01	11,91	1023,9	4,00	14,47	1244,3	5,58	17,01	1462,6	7,33	*	*	*
	2100	9,41	1618,7	9,38	12,26	2107,8	14,81	13,33	1146,5	4,90	16,23	1395,6	6,86	19,10	1642,4	9,03	*	*	*
	2550	10,84	1864,9	12,11	14,14	2431,8	19,15	15,31	1316,6	6,29	18,67	1605,3	8,82	22,02	1893,6	11,67	28,68	2466,0	18,14
	3000	12,16	2090,7	14,87	15,89	2731,9	23,61	17,13	1472,8	7,69	20,91	1798,3	10,82	24,69	2122,9	14,33	32,22	2770,0	22,36

LEGEND

WT = Water temperature

Ph = Emission

Qw = Water flow

Dp(c) = Water pressure drop

Qv = Air flow

* Operating points outside the range of application of the electric motor

Performance data

Heating emission of MAC Size 4 units

Entering air temperature: 5°C

Model	WT: 40/35°C				WT: 45/40°C				WT: 50/40°C				WT: 55/45°C				WT: 60/50°C				WT: 70/60°C			
	Qv m³/h	Ph kW	Qw l/h	Dp(c) kPa	Ph kW	Qw l/h	Dp(c) kPa	Ph kW	Qw l/h	Dp(c) kPa	Ph kW	Qw l/h	Dp(c) kPa	Ph kW	Qw l/h	Dp(c) kPa	Ph kW	Qw l/h	Dp(c) kPa	Ph kW	Qw l/h	Dp(c) kPa		
MAC 42	2400	15,48	2662,8	11,07	18,06	3106,0	14,33	17,22	1480,6	4,22	18,68	1605,8	5,17	23,79	2045,1	6,46	29,03	2495,8	8,93					
	2900	17,55	3018,3	13,88	20,50	3525,4	18,00	19,41	1668,7	5,24	21,04	1808,8	6,40	26,92	2314,6	8,07	32,92	2830,8	11,20					
	3400	19,43	3340,5	16,65	22,72	3906,7	21,66	21,43	1842,6	6,26	23,19	1994,3	7,63	29,82	2563,5	9,69	36,50	3138,1	13,49					
	3900	21,20	3645,1	19,49	24,79	4263,2	25,34	23,28	2001,4	7,27	25,19	2165,8	8,85	32,49	2793,8	11,32	39,80	3422,4	15,76					
	4500	23,15	3981,0	22,84	27,08	4656,8	29,71	25,35	2179,9	8,48	27,39	2355,2	10,29	35,48	3050,7	13,26	43,50	3740,2	18,50					
MAC 43	2400	20,10	3457,1	20,30	23,34	4013,8	26,06	23,40	2012,1	8,41	25,65	2205,3	10,48	31,04	2669,2	11,95	37,55	3228,7	16,27					
	2900	23,10	3972,1	26,07	26,82	4612,0	33,46	26,76	2301,3	10,71	29,34	2522,5	13,35	35,64	3064,0	15,32	43,16	3710,8	20,90					
	3400	25,87	4448,1	31,96	30,06	5168,5	41,08	30,00	2579,7	13,16	32,69	2810,7	16,22	39,87	3428,2	18,75	48,31	4153,4	25,60					
	3900	28,47	4895,3	37,97	33,07	5687,4	48,80	33,02	2839,0	15,63	35,85	3082,0	19,14	43,84	3769,7	22,24	53,17	4572,0	30,43					
	4500	31,38	5395,5	45,24	36,48	6273,3	58,22	36,35	3125,3	18,58	39,45	3392,3	22,75	48,28	4151,0	26,46	58,62	5040,5	36,27					
MAC 44	2400	23,01	3956,7	17,77	26,65	4581,9	22,70	27,17	2336,5	7,55	29,86	2567,5	9,46	35,63	3063,7	10,51	*	*	*					
	2900	26,71	4593,9	23,24	30,93	5319,2	29,69	31,37	2697,1	9,78	34,45	2962,3	12,23	41,32	3552,6	13,72	49,84	4285,4	18,59					
	3400	30,17	5187,7	28,93	34,97	6013,8	37,03	35,35	3039,2	12,13	38,75	3331,4	15,11	46,63	4009,3	17,06	56,33	4843,5	23,17					
	3900	33,42	5747,7	34,79	38,77	6666,2	44,57	39,18	3368,8	14,60	42,76	3676,4	18,05	51,63	4439,5	20,49	62,42	5367,3	27,87					
	4500	37,10	6379,0	41,97	43,08	7408,1	53,89	43,49	3739,5	17,61	47,24	4061,3	21,59	57,27	4923,8	24,69	69,30	5958,2	33,64					

Entering air temperature: 10°C

Model	WT: 40/35°C				WT: 45/40°C				WT: 50/40°C				WT: 55/45°C				WT: 60/50°C				WT: 70/60°C			
	Qv m³/h	Ph kW	Qw l/h	Dp(c) kPa	Ph kW	Qw l/h	Dp(c) kPa	Ph kW	Qw l/h	Dp(c) kPa	Ph kW	Qw l/h	Dp(c) kPa	Ph kW	Qw l/h	Dp(c) kPa	Ph kW	Qw l/h	Dp(c) kPa	Ph kW	Qw l/h	Dp(c) kPa		
MAC 42	2400	12,79	2200,0	7,85	15,35	2640,3	10,70	14,02	1205,9	3,28	15,04	1293,5	3,90	21,00	1805,3	5,16	26,17	2250,5	7,41					
	2900	14,50	2493,1	9,84	17,41	2994,6	13,42	15,78	1357,1	4,06	16,89	1452,4	4,81	23,79	2045,8	6,46	29,68	2551,6	9,29					
	3400	16,06	2762,0	11,83	19,31	3319,7	16,16	17,37	1493,8	4,83	18,56	1595,6	5,70	26,34	2264,5	7,75	32,92	2830,6	11,20					
	3900	17,51	3011,0	13,82	21,05	3620,5	18,89	18,87	1622,3	5,60	20,09	1727,7	6,57	28,69	2466,5	9,04	35,89	3086,2	13,09					
	4500	19,13	3288,9	16,19	23,01	3956,7	22,16	20,49	1761,5	6,49	21,81	1875,2	7,62	31,34	2694,8	10,61	39,22	3371,7	15,35					
MAC 43	2400	16,71	2873,0	14,55	19,89	3420,6	19,54	19,50	1677,0	6,81	21,39	1839,3	8,43	27,50	2364,4	9,61	33,90	2915,1	13,54					
	2900	19,18	3298,8	18,66	22,86	3931,6	25,11	22,27	1914,5	8,65	24,36	2094,8	10,65	31,55	2713,0	12,30	38,96	3349,6	17,38					
	3400	21,49	3694,6	22,88	25,63	4407,8	30,84	24,81	2133,4	10,51	27,13	2333,0	12,93	35,29	3034,2	15,05	43,66	3754,2	21,34					
	3900	23,63	4063,7	27,16	28,20	4848,6	36,62	27,19	2337,7	12,39	29,69	2553,0	15,21	38,82	3338,0	17,87	48,02	4128,6	25,33					
	4500	26,05	4479,9	32,37	31,09	5346,1	43,65	29,84	2565,9	14,65	32,54	2797,9	17,94	42,73	3674,1	21,24	52,93	4550,9	30,18					
MAC 44	2400	19,17	3295,8	12,79	22,75	3911,3	17,07	22,80	1960,2	6,19	25,06	2154,8	7,69	31,60	2716,7	8,46	*	*	*					
	2900	22,23	3822,3	16,69	26,40	4539,4	22,32	26,27	2258,5	7,99	28,84	2479,8	9,91	36,60	3147,1	11,03	45,05	3873,1	15,49					
	3400	25,09	4314,4	20,76	29,84	5130,8	27,82	29,48	2534,6	9,83	32,33	2779,9	12,17	41,30	3550,6	13,71	50,87	4374,0	19,28					
	3900	27,79	4778,0	24,95	33,07	5686,0	33,47	32,54	2798,0	11,75	35,66	3065,7	14,51	45,75	3933,2	16,48	56,37	4846,3	23,19					
	4500	30,84	5304,1	30,11	36,73	6316,9	40,45	35,93	3089,1	14,04	39,35	3383,6	17,33	50,76	4364,2	19,87	62,61	5382,9	28,02					

LEGEND

WT = Water temperature

Ph = Emission

Qw = Water flow

Dp(c) = Water pressure drop

Qv = Air flow

* Operating points outside the range of application of the electric motor

Performance data

Heating emission of MAC Size 4 units

Entering air temperature: 15°C

Model	WT: 40/35°C				WT: 45/40°C			WT: 50/40°C			WT: 55/45°C			WT: 60/50°C			WT: 70/60°C		
	Qv m³/h	Ph kW	Qw l/h	Dp(c) kPa	Ph kW	Qw l/h	Dp(c) kPa	Ph kW	Qw l/h	Dp(c) kPa	Ph kW	Qw l/h	Dp(c) kPa	Ph kW	Qw l/h	Dp(c) kPa	Ph kW	Qw l/h	Dp(c) kPa
MAC 42	2400	10,19	1751,6	5,21	12,72	2186,6	7,62	10,85	933,1	2,35	11,35	975,5	2,64	18,28	1571,7	4,02	23,40	2012,0	6,06
	2900	11,53	1983,3	6,52	14,41	2477,3	9,54	12,16	1046,0	2,89	12,68	1090,5	3,23	20,69	1779,3	5,02	26,52	2280,0	7,59
	3400	12,77	2195,9	7,83	15,97	2746,3	11,48	13,37	1149,4	3,42	13,89	1194,6	3,81	22,93	1971,9	6,05	29,40	2528,2	9,14
	3900	13,92	2392,9	9,14	17,42	2995,7	13,43	14,47	1244,0	3,95	15,00	1289,6	4,37	24,96	2146,0	7,04	32,08	2758,4	10,69
	4500	15,17	2609,2	10,68	19,02	3270,6	15,73	15,67	1347,2	4,55	16,19	1392,5	5,02	27,24	2342,5	8,24	35,03	3012,2	12,53
MAC 43	2400	13,41	2306,1	9,80	16,55	2845,9	14,03	15,65	1345,4	5,21	17,05	1466,0	6,31	24,05	2067,8	7,55	30,39	2612,5	11,11
	2900	15,39	2647,1	12,56	19,01	3269,0	18,01	17,82	1532,5	6,58	19,36	1664,9	7,93	27,58	2371,2	9,66	34,90	3001,1	14,26
	3400	17,22	2962,0	15,37	21,28	3659,8	22,07	19,80	1702,8	7,96	21,48	1846,5	9,56	30,85	2652,6	11,82	39,08	3360,2	17,48
	3900	18,91	3252,1	18,19	23,44	4030,1	26,25	21,65	1861,1	9,34	23,44	2015,0	11,19	33,92	2916,8	14,02	43,04	3700,4	20,79
	4500	20,84	3584,5	21,67	25,82	4440,9	31,26	23,71	2038,9	11,00	25,66	2206,2	13,17	37,35	3211,5	16,67	47,43	4077,9	24,77
MAC 44	2400	15,42	2652,3	8,65	18,95	3259,2	12,29	18,45	1586,6	4,81	20,26	1741,6	5,90	27,67	2379,3	6,67	*	*	*
	2900	17,86	3071,7	11,26	21,99	3780,9	16,06	21,20	1822,4	6,17	23,20	1994,5	7,54	32,07	2757,0	8,69	*	*	*
	3400	20,15	3464,6	13,99	24,82	4268,8	19,98	23,76	2042,7	7,58	25,93	2229,1	9,21	36,16	3109,4	10,79	45,57	3918,4	15,82
	3900	22,31	3837,0	16,81	27,52	4732,0	24,05	26,11	2245,1	8,98	28,49	2449,4	10,91	40,02	3440,7	12,95	50,56	4346,9	19,07
	4500	24,75	4256,1	20,26	30,56	5254,6	29,04	28,81	2477,5	10,72	31,37	2697,1	12,97	44,38	3816,0	15,60	56,10	4823,8	23,00

Entering air temperature: 20°C

Model	WT: 40/35°C				WT: 45/40°C			WT: 50/40°C			WT: 55/45°C			WT: 60/50°C			WT: 70/60°C		
	Qv m³/h	Ph kW	Qw l/h	Dp(c) kPa	Ph kW	Qw l/h	Dp(c) kPa	Ph kW	Qw l/h	Dp(c) kPa	Ph kW	Qw l/h	Dp(c) kPa	Ph kW	Qw l/h	Dp(c) kPa	Ph kW	Qw l/h	Dp(c) kPa
MAC 42	2400	7,64	1313,7	3,10	10,13	1742,0	5,06	10,57	909,1	1,56	13,11	1127,0	2,25	15,64	1344,8	3,04	20,67	1777,5	4,85
	2900	8,64	1485,9	3,87	11,47	1971,9	6,33	11,93	1026,1	1,93	14,82	1274,4	2,80	17,70	1521,9	3,79	23,46	2016,9	6,09
	3400	9,55	1642,3	4,64	12,71	2184,8	7,61	13,15	1131,0	2,30	16,36	1406,8	3,35	19,59	1684,5	4,55	26,00	2235,2	7,32
	3900	10,39	1787,0	5,40	13,85	2382,3	8,89	14,30	1229,7	2,68	17,83	1532,8	3,91	21,32	1833,2	5,30	28,35	2437,3	8,56
	4500	11,34	1950,2	6,32	15,14	2602,8	10,43	15,57	1338,9	3,12	19,43	1670,9	4,57	23,27	2001,0	6,21	30,97	2663,1	10,04
MAC 43	2400	10,19	1752,5	5,98	13,29	2285,4	9,46	14,39	1237,2	3,10	17,55	1508,5	4,35	20,70	1779,6	5,76	26,93	2315,9	8,95
	2900	11,67	2006,3	7,62	15,25	2622,4	12,11	16,44	1413,9	3,95	20,08	1726,9	5,55	23,72	2039,0	7,36	30,95	2661,3	11,49
	3400	13,05	2244,7	9,33	17,07	2935,4	14,84	18,33	1575,6	4,80	22,43	1928,9	6,78	26,51	2279,3	8,99	34,64	2978,6	14,07
	3900	14,33	2464,8	11,04	18,78	3229,6	17,62	20,10	1728,1	5,66	24,64	2118,2	8,02	29,13	2504,4	10,65	38,14	3279,1	16,73
	4500	15,77	2712,0	13,12	20,71	3561,4	21,01	22,06	1896,9	6,70	27,08	2328,6	9,51	32,07	2757,7	12,67	42,05	3615,4	19,94
MAC 44	2400	11,77	2024,7	5,32	15,26	2624,0	8,32	16,75	1440,3	2,80	20,32	1746,7	3,89	23,85	2050,4	5,10	*	*	*
	2900	13,63	2343,4	6,92	17,70	3043,8	10,87	19,33	1661,8	3,62	23,48	2019,0	5,05	27,62	2374,5	6,64	*	*	*
	3400	15,35	2640,0	8,58	19,97	3434,3	13,51	21,72	1867,7	4,47	26,44	2273,0	6,25	31,13	2676,4	8,24	0,00	0,0	0,00
	3900	16,97	2918,2	10,27	22,11	3801,8	16,22	23,98	2061,5	5,34	29,20	2511,0	7,48	34,45	2962,2	9,89	44,82	3854,0	15,36
	4500	18,81	3235,1	12,36	24,55	4221,6	19,58	26,51	2279,7	6,40	32,35	2781,8	8,99	38,19	3283,3	11,90	49,76	4278,8	18,53

LEGEND

WT = Water temperature

Ph = Emission

Qw = Water flow

Dp(c) = Water pressure drop

Qv = Air flow

* Operating points outside the range of application of the electric motor

Performance data

Cooling emission of MAC Size 1 units

Entering air temperature: 27°C - Relative Humidity: 50%

Model	Qv m ³ /h	WT: 7/12°C				WT: 8/13°C				WT: 10/15°C				WT: 12/17°C			
		Pc kW	Ps kW	Qw l/h	Dp(c) kPa	Pc kW	Ps kW	Qw l/h	Dp(c) kPa	Pc kW	Ps kW	Qw l/h	Dp(c) kPa	Pc kW	Ps kW	Qw l/h	Dp(c) kPa
MAC 13	600	3,07	2,21	527,5	4,68	2,73	2,13	469,3	3,77	2,11	1,98	363,4	2,36	1,60	1,53	275,3	1,42
	800	3,64	2,71	626,1	6,37	3,24	2,64	557,7	5,15	2,53	2,41	435,7	3,27	1,94	1,85	334,1	2,01
	1000	4,12	3,21	708,5	7,96	3,69	3,10	634,3	6,49	2,90	2,74	499,3	4,18	2,24	2,13	385,9	2,60
	1200	4,57	3,59	785,8	9,59	4,13	3,54	710,7	7,96	3,23	3,05	555,4	5,06	2,52	2,39	432,5	3,20
	1400	4,93	3,99	848,2	11,00	4,43	3,92	761,6	9,02	3,53	3,33	607,0	5,94	2,77	2,62	476,0	3,80
MAC 14	600	3,63	2,56	624,9	3,78	3,23	2,42	555,3	3,04	2,48	2,20	425,7	1,87	1,85	1,78	317,4	1,09
	800	4,39	3,17	754,3	5,31	3,90	3,03	670,1	4,27	3,01	2,78	517,7	2,66	2,27	2,18	389,8	1,58
	1000	5,02	3,74	863,8	6,77	4,47	3,59	768,9	5,47	3,47	3,31	596,2	3,43	2,64	2,53	453,5	2,07
	1200	5,58	4,25	959,8	8,19	4,97	4,11	854,2	6,61	3,89	3,70	668,3	4,21	2,98	2,84	511,6	2,58
	1400	6,05	4,75	1040,7	9,47	5,44	4,61	935,7	7,78	4,26	4,06	733,4	4,97	3,28	3,14	564,7	3,08
MAC 16	600	4,72	3,09	811,0	7,14	4,22	2,90	726,3	5,83	3,26	2,55	560,2	3,62	2,40	2,25	411,9	2,06
	800	5,85	3,90	1005,9	10,52	5,23	3,67	898,8	8,55	4,03	3,25	693,2	5,31	2,98	2,88	512,7	3,06
	1000	6,84	4,64	1176,9	13,95	6,10	4,38	1049,7	11,30	4,71	3,92	810,4	7,03	3,51	3,39	603,2	4,09
	1200	7,73	5,33	1328,9	17,36	6,89	5,05	1185,4	14,07	5,34	4,56	917,4	8,79	3,99	3,84	686,8	5,17
	1400	8,53	5,98	1466,3	20,73	7,61	5,69	1309,4	16,83	5,90	5,17	1014,3	10,53	4,44	4,27	763,9	6,26

Entering air temperature: 26°C - Relative Humidity: 50%

Model	Qv m ³ /h	WT: 7/12°C				WT: 8/13°C				WT: 10/15°C				WT: 12/17°C			
		Pc kW	Ps kW	Qw l/h	Dp(c) kPa	Pc kW	Ps kW	Qw l/h	Dp(c) kPa	Pc kW	Ps kW	Qw l/h	Dp(c) kPa	Pc kW	Ps kW	Qw l/h	Dp(c) kPa
MAC 13	600	2,71	2,12	466,8	3,76	2,40	2,04	412,9	3,00	1,84	1,76	317,0	1,85	1,41	1,34	243,2	1,13
	800	3,23	2,63	554,7	5,12	2,87	2,55	493,1	4,13	2,23	2,11	382,7	2,59	1,84	1,74	317,1	1,83
	1000	3,64	3,09	626,7	6,38	3,27	3,01	561,8	5,22	2,56	2,42	440,0	3,33	2,21	2,07	380,3	2,54
	1200	4,06	3,55	698,7	7,76	3,63	3,42	623,5	6,29	2,86	2,70	491,6	4,06	2,49	2,33	427,8	3,14
	1400	4,41	3,90	758,2	8,99	3,95	3,72	678,9	7,33	3,13	2,96	538,5	4,79	2,74	2,56	471,2	3,73
MAC 14	600	3,21	2,42	551,3	3,02	2,83	2,30	486,5	2,40	2,15	2,06	368,9	1,44	1,59	1,54	273,6	0,84
	800	3,87	3,03	666,0	4,24	3,42	2,90	588,7	3,38	2,62	2,51	450,5	2,07	2,02	1,93	347,9	1,29
	1000	4,45	3,58	765,4	5,45	3,94	3,45	676,9	4,35	3,03	2,90	521,2	2,69	2,48	2,37	427,3	1,86
	1200	4,95	4,10	851,4	6,60	4,40	3,97	756,4	5,31	3,41	3,25	585,8	3,32	2,94	2,79	505,1	2,52
	1400	5,42	4,60	931,3	7,76	4,81	4,45	827,9	6,25	3,75	3,57	644,7	3,94	3,30	3,10	566,9	3,10
MAC 16	600	4,19	2,91	720,9	5,77	3,71	2,72	638,5	4,62	2,81	2,39	483,1	2,77	2,04	1,98	350,9	1,54
	800	5,19	3,68	892,3	8,48	4,60	3,46	790,3	6,78	3,48	3,07	598,5	4,07	2,55	2,47	438,5	2,31
	1000	6,07	4,39	1043,8	11,24	5,37	4,15	922,7	8,96	4,09	3,71	702,7	5,44	3,01	2,92	518,1	3,11
	1200	6,85	5,06	1177,8	13,97	6,07	4,79	1044,0	11,19	4,63	4,33	796,1	6,81	3,44	3,32	591,8	3,96
	1400	7,57	5,69	1302,2	16,74	6,70	5,41	1153,0	13,38	5,14	4,92	884,3	8,23	3,84	3,70	660,3	4,82

Entering air temperature: 25°C - Relative Humidity: 50%

Model	Qv m ³ /h	WT: 7/12°C				WT: 8/13°C				WT: 10/15°C				WT: 12/17°C			
		Pc kW	Ps kW	Qw l/h	Dp(c) kPa	Pc kW	Ps kW	Qw l/h	Dp(c) kPa	Pc kW	Ps kW	Qw l/h	Dp(c) kPa	Pc kW	Ps kW	Qw l/h	Dp(c) kPa
MAC 13	600	2,39	2,04	410,8	2,98	2,10	1,96	361,8	2,36	1,61	1,54	276,4	1,44	1,40	1,32	241,5	1,12
	800	2,86	2,54	491,0	4,11	2,53	2,40	434,4	3,28	1,95	1,86	335,0	2,04	1,71	1,61	294,4	1,60
	1000	3,27	3,00	561,5	5,24	2,89	2,74	497,3	4,19	2,25	2,14	387,2	2,64	1,98	1,86	341,1	2,09
	1200	3,61	3,40	621,5	6,29	3,22	3,04	553,4	5,08	2,52	2,39	434,0	3,25	2,23	2,09	383,1	2,57
	1400	3,93	3,71	676,6	7,32	3,51	3,31	604,4	5,95	2,78	2,63	477,5	3,86	2,46	2,29	422,5	3,07
MAC 14	600	2,81	2,30	484,1	2,39	2,47	2,19	424,5	1,88	1,86	1,79	319,2	1,11	1,63	1,55	280,6	0,87
	800	3,41	2,89	586,8	3,38	3,00	2,76	515,4	2,66	2,28	2,19	391,3	1,61	2,02	1,91	346,7	1,28
	1000	3,93	3,44	675,0	4,34	3,46	3,30	595,3	3,45	2,64	2,54	454,8	2,10	2,36	2,23	405,4	1,70
	1200	4,38	3,95	753,7	5,30	3,88	3,69	666,4	4,23	2,99	2,85	513,5	2,62	2,67	2,52	459,0	2,12
	1400	4,80	4,44	825,1	6,24	4,25	4,04	730,9	4,99	3,30	3,15	566,8	3,13	2,96	2,78	509,0	2,55
MAC 16	600	3,70	2,73	635,5	4,60	3,24	2,55	556,9	3,61	2,41	2,24	413,6	2,10	1,74	1,69	298,7	1,16
	800	4,57	3,46	786,4	6,75	4,01	3,26	689,4	5,30	3,00	2,90	515,2	3,11	2,28	2,20	391,4	1,88
	1000	5,35	4,15	919,4	8,95	4,69	3,91	806,9	7,04	3,52	3,40	605,8	4,16	2,81	2,72	483,4	2,75
	1200	6,04	4,79	1039,1	11,15	5,31	4,54	912,8	8,79	4,01	3,86	689,7	5,26	3,34	3,22	574,4	3,75
	1400	6,68	5,41	1148,6	13,36	5,88	5,15	1011,2	10,57	4,46	4,29	767,1	6,37	3,87	3,73	664,8	4,88

LEGEND

WT = Water temperature
Qw = Water flow

Pc = Cooling total emission
Dp(c) = Water pressure drop

Ps = Cooling sensible emission
Qv = Air flow

Performance data

Cooling emission of MAC Size 2 units

Entering air temperature: 27°C - Relative Humidity: 50%

Model	Qv m³/h	WT: 7/12°C				WT: 8/13°C				WT: 10/15°C				WT: 12/17°C			
		Pc kW	Ps kW	Qw l/h	Dp(c) kPa	Pc kW	Ps kW	Qw l/h	Dp(c) kPa	Pc kW	Ps kW	Qw l/h	Dp(c) kPa	Pc kW	Ps kW	Qw l/h	Dp(c) kPa
MAC 23	1000	4,94	3,57	848,8	5,31	4,40	3,45	755,8	4,29	3,42	3,22	587,8	2,70	2,60	2,46	446,4	1,63
	1275	5,70	4,25	979,4	6,87	5,09	4,13	875,0	5,58	3,98	3,74	683,6	3,55	3,06	2,89	525,5	2,19
	1550	6,35	4,85	1091,4	8,35	5,68	4,75	977,3	6,81	4,47	4,20	769,5	4,39	3,46	3,27	595,5	2,74
	1825	6,94	5,44	1194,1	9,81	6,25	5,38	1074,6	8,08	4,93	4,61	847,3	5,22	3,84	3,61	660,1	3,30
	2100	7,55	5,98	1297,8	11,40	6,81	5,88	1171,8	9,44	5,33	4,99	917,4	6,02	4,19	3,93	720,1	3,86
MAC 24	1000	5,88	4,15	1011,2	4,34	5,23	3,95	899,2	3,49	4,01	3,60	689,4	2,15	3,00	2,88	516,4	1,26
	1275	6,89	4,98	1184,4	5,76	6,12	4,77	1053,2	4,64	4,73	4,39	813,2	2,89	3,57	3,40	613,8	1,72
	1550	7,75	5,74	1331,9	7,12	6,89	5,52	1184,2	5,73	5,35	5,07	919,7	3,60	4,07	3,87	699,6	2,18
	1825	8,50	6,45	1461,8	8,42	7,59	6,24	1305,7	6,84	5,92	5,59	1018,1	4,33	4,53	4,30	778,8	2,65
	2100	9,25	7,13	1591,0	9,80	8,25	6,92	1418,5	7,93	6,44	6,09	1108,0	5,04	4,96	4,71	853,2	3,12
MAC 26	1000	7,70	5,06	1323,9	8,31	6,89	4,75	1185,0	6,78	5,31	4,18	913,6	4,20	3,91	3,71	673,2	2,40
	1275	9,21	6,14	1583,9	11,48	8,23	5,78	1414,9	9,33	6,35	5,14	1091,3	5,79	4,70	4,52	809,0	3,35
	1550	10,54	7,14	1813,0	14,64	9,42	6,75	1619,3	11,89	7,26	6,04	1249,3	7,38	5,41	5,20	931,1	4,31
	1825	11,77	8,08	2023,3	17,84	10,51	7,66	1806,5	14,48	8,12	6,91	1396,4	9,02	6,08	5,82	1046,0	5,32
	2100	12,87	8,97	2213,2	20,96	11,49	8,54	1975,0	17,00	8,91	7,75	1532,9	10,67	6,70	6,41	1152,9	6,33

Entering air temperature: 26°C - Relative Humidity: 50%

Model	Qv m³/h	WT: 7/12°C				WT: 8/13°C				WT: 10/15°C				WT: 12/17°C			
		Pc kW	Ps kW	Qw l/h	Dp(c) kPa	Pc kW	Ps kW	Qw l/h	Dp(c) kPa	Pc kW	Ps kW	Qw l/h	Dp(c) kPa	Pc kW	Ps kW	Qw l/h	Dp(c) kPa
MAC 23	1000	4,38	3,45	752,7	4,28	3,88	3,33	666,6	3,42	2,98	2,82	513,2	2,12	2,36	2,21	405,2	1,37
	1275	5,06	4,12	869,8	5,55	4,49	4,00	772,7	4,46	3,49	3,30	600,8	2,81	2,95	2,76	507,1	2,05
	1550	5,65	4,74	972,2	6,78	5,04	4,63	866,4	5,48	3,94	3,71	677,8	3,49	3,42	3,17	588,3	2,68
	1825	6,21	5,32	1067,9	8,03	5,53	5,17	951,0	6,48	4,36	4,09	749,2	4,18	3,80	3,52	654,1	3,25
	2100	6,87	5,85	1180,7	9,62	5,98	5,58	1028,9	7,47	4,74	4,44	814,3	4,86	4,15	3,84	714,2	3,80
MAC 24	1000	5,20	3,95	894,3	3,48	4,58	3,76	787,8	2,75	3,48	3,33	598,8	1,66	2,59	2,49	445,9	0,97
	1275	6,09	4,77	1047,8	4,62	5,38	4,56	924,8	3,67	4,12	3,92	707,8	2,25	3,23	3,06	556,0	1,44
	1550	6,85	5,50	1178,2	5,71	6,07	5,30	1043,8	4,57	4,67	4,44	803,7	2,83	3,87	3,66	665,1	1,99
	1825	7,54	6,21	1297,1	6,79	6,69	6,01	1150,5	5,44	5,19	4,92	892,5	3,41	4,49	4,24	773,0	2,61
	2100	8,18	6,90	1406,3	7,85	7,28	6,67	1251,1	6,33	5,67	5,36	974,6	4,00	4,99	4,65	857,7	3,15
MAC 26	1000	6,84	4,76	1177,0	6,73	6,06	4,46	1042,0	5,38	4,59	3,93	788,4	3,22	3,34	3,23	574,0	1,80
	1275	8,18	5,79	1406,5	9,27	7,24	5,46	1244,5	7,40	5,49	4,85	943,3	4,45	4,03	3,88	692,5	2,53
	1550	9,35	6,76	1608,4	11,80	8,28	6,38	1423,7	9,43	6,30	5,72	1083,7	5,72	4,65	4,48	800,1	3,28
	1825	10,44	7,67	1794,7	14,37	9,24	7,27	1588,1	11,48	7,04	6,57	1211,2	6,98	5,24	5,03	900,7	4,06
	2100	11,43	8,53	1965,5	16,93	10,13	8,12	1742,1	13,56	7,75	7,38	1331,9	8,29	5,79	5,55	996,2	4,87

Entering air temperature: 25°C - Relative Humidity: 50%

Model	Qv m³/h	WT: 7/12°C				WT: 8/13°C				WT: 10/15°C				WT: 12/17°C			
		Pc kW	Ps kW	Qw l/h	Dp(c) kPa	Pc kW	Ps kW	Qw l/h	Dp(c) kPa	Pc kW	Ps kW	Qw l/h	Dp(c) kPa	Pc kW	Ps kW	Qw l/h	Dp(c) kPa
MAC 23	1000	3,86	3,32	664,0	3,41	3,40	3,20	585,2	2,71	2,61	2,47	448,1	1,66	2,29	2,13	393,4	1,30
	1275	4,48	4,00	770,2	4,46	3,96	3,73	681,4	3,56	3,07	2,90	527,4	2,22	2,70	2,51	464,5	1,75
	1550	5,04	4,60	866,4	5,51	4,46	4,18	766,5	4,40	3,47	3,27	597,0	2,78	3,07	2,84	527,5	2,20
	1825	5,51	5,15	948,2	6,48	4,90	4,59	843,4	5,22	3,85	3,62	661,5	3,34	3,41	3,15	585,9	2,66
	2100	5,96	5,56	1025,5	7,46	5,32	4,97	914,6	6,04	4,20	3,94	721,6	3,91	3,72	3,44	639,9	3,12
MAC 24	1000	4,57	3,75	785,3	2,75	4,00	3,58	688,5	2,16	3,02	2,89	518,5	1,28	2,67	2,51	458,9	1,02
	1275	5,36	4,55	922,1	3,67	4,70	4,36	808,9	2,89	3,58	3,42	616,2	1,75	3,18	2,99	547,0	1,40
	1550	6,04	5,29	1039,3	4,55	5,35	5,05	919,7	3,64	4,08	3,89	702,3	2,22	3,65	3,42	627,8	1,80
	1825	6,68	5,99	1147,9	5,45	5,90	5,57	1015,2	4,35	4,55	4,32	781,7	2,69	4,08	3,81	701,4	2,19
	2100	7,25	6,66	1247,3	6,32	6,42	6,06	1104,3	5,06	4,98	4,72	856,3	3,17	4,48	4,17	769,7	2,59
MAC 26	1000	6,02	4,47	1036,1	5,35	5,28	4,19	908,8	4,20	3,93	3,70	676,1	2,45	2,88	2,78	495,4	1,38
	1275	7,20	5,46	1238,3	7,37	6,32	5,14	1086,8	5,80	4,72	4,54	812,5	3,40	3,63	3,50	625,0	2,10
	1550	8,24	6,39	1417,3	9,40	7,24	6,03	1245,8	7,42	5,44	5,22	935,1	4,38	4,37	4,20	751,7	2,93
	1825	9,20	7,26	1581,3	11,44	8,08	6,90	1389,8	9,03	6,11	5,84	1050,5	5,41	5,10	4,90	877,5	3,87
	2100	10,09	8,11	1734,8	13,52	8,88	7,72	1526,9	10,70	6,73	6,43	1157,7	6,44	5,83	5,59	1002,5	4,92

LEGEND

WT = Water temperature
Qw = Water flow

Pc = Cooling total emission
Dp(c) = Water pressure drop

Ps = Cooling sensible emission
Qv = Air flow

Performance data

Cooling emission of MAC Size 3 units

Entering air temperature: 27°C - Relative Humidity: 50%

Model	WT: 7/12°C					WT: 8/13°C				WT: 10/15°C				WT: 12/17°C			
	Qv m³/h	Pc kW	Ps kW	Qw l/h	Dp(c) kPa	Pc kW	Ps kW	Qw l/h	Dp(c) kPa	Pc kW	Ps kW	Qw l/h	Dp(c) kPa	Pc kW	Ps kW	Qw l/h	Dp(c) kPa
MAC 33	1500	7,61	5,27	1307,9	12,91	6,78	5,10	1165,6	10,44	5,29	4,79	909,8	6,62	4,04	3,79	694,6	4,04
	1800	8,44	5,97	1452,0	15,58	7,55	5,81	1298,1	12,67	5,92	5,51	1018,5	8,11	4,56	4,26	783,9	5,02
	2100	9,20	6,62	1582,5	18,19	8,24	6,47	1416,2	14,82	6,50	6,03	1117,9	9,59	5,02	4,69	863,8	5,98
	2550	10,21	7,54	1755,7	21,92	9,16	7,42	1576,0	17,97	7,28	6,73	1251,4	11,75	5,67	5,28	975,5	7,44
	3000	11,11	8,40	1910,2	25,52	10,00	8,31	1720,0	21,03	7,98	7,37	1372,9	13,89	6,27	5,82	1077,5	8,90
MAC 34	1500	9,11	6,21	1566,1	10,63	8,11	5,91	1395,4	8,60	6,27	5,40	1077,6	5,35	4,70	4,46	808,5	3,16
	1800	10,22	7,09	1756,6	13,07	9,11	6,79	1566,1	10,58	7,07	6,25	1216,0	6,65	5,34	5,05	917,6	3,97
	2100	11,22	7,90	1929,2	15,48	10,01	7,60	1721,8	12,55	7,78	7,06	1338,7	7,91	5,92	5,58	1017,9	4,78
	2550	12,56	9,05	2159,4	18,96	11,20	8,75	1925,2	15,35	8,77	8,21	1508,4	9,80	6,72	6,32	1156,3	6,02
	3000	13,73	10,12	2361,1	22,27	12,30	9,88	2115,6	18,19	9,67	9,02	1662,3	11,67	7,46	7,00	1282,8	7,25
MAC 36	1500	11,75	7,59	2020,9	20,43	10,54	7,13	1812,5	16,71	8,17	6,29	1404,9	10,47	6,04	5,59	1039,1	6,03
	1800	13,44	8,75	2310,3	25,99	12,03	8,25	2068,2	21,19	9,33	7,33	1604,3	13,29	6,93	6,56	1191,9	7,72
	2100	14,96	9,85	2572,2	31,53	13,39	9,31	2302,0	25,70	10,38	8,32	1785,2	16,11	7,74	7,38	1331,1	9,41
	2550	17,03	11,38	2928,8	39,83	15,23	10,80	2618,9	32,42	11,84	9,75	2035,9	20,41	8,88	8,44	1527,5	12,06
	3000	18,89	12,82	3248,2	47,99	16,90	12,21	2906,4	39,10	13,18	11,11	2266,0	24,75	9,94	9,42	1709,5	14,77

Entering air temperature: 26°C - Relative Humidity: 50%

Model	WT: 7/12°C					WT: 8/13°C				WT: 10/15°C				WT: 12/17°C			
	Qv m³/h	Pc kW	Ps kW	Qw l/h	Dp(c) kPa	Pc kW	Ps kW	Qw l/h	Dp(c) kPa	Pc kW	Ps kW	Qw l/h	Dp(c) kPa	Pc kW	Ps kW	Qw l/h	Dp(c) kPa
MAC 33	1500	6,75	5,10	1160,8	10,41	5,99	4,92	1030,5	8,36	4,64	4,34	797,2	5,22	3,52	3,31	605,6	3,15
	1800	7,50	5,80	1290,4	12,60	6,69	5,64	1150,0	10,19	5,21	4,86	895,6	6,44	3,98	3,74	684,5	3,93
	2100	8,20	6,46	1409,5	14,76	7,31	6,31	1257,3	11,96	5,73	5,33	984,9	7,64	4,43	4,13	761,1	4,76
	2550	9,13	7,42	1570,0	17,93	8,16	7,26	1402,8	14,57	6,44	5,98	1107,2	9,43	5,29	4,83	910,1	6,57
	3000	9,94	8,28	1708,7	20,88	8,93	8,16	1535,5	17,14	7,08	6,56	1218,2	11,20	6,14	5,60	1056,6	8,59
MAC 34	1500	8,06	5,91	1385,9	8,53	7,13	5,64	1226,4	6,82	5,45	5,15	937,2	4,16	4,06	3,86	698,7	2,43
	1800	9,07	6,78	1559,4	10,55	8,04	6,49	1382,2	8,45	6,17	5,81	1060,2	5,20	4,63	4,39	795,6	3,07
	2100	9,96	7,59	1713,1	12,50	8,83	7,30	1518,5	10,01	6,81	6,41	1171,3	6,22	5,15	4,87	885,5	3,72
	2550	11,15	8,74	1918,0	15,32	9,92	8,46	1706,3	12,35	7,70	7,23	1324,5	7,76	5,87	5,54	1009,6	4,71
	3000	12,25	9,82	2106,7	18,13	10,90	9,53	1875,0	14,63	8,52	7,97	1464,5	9,29	6,81	6,29	1171,5	6,16
MAC 36	1500	10,46	7,15	1798,8	16,56	9,30	6,71	1598,6	13,33	7,06	5,92	1214,3	8,05	5,16	4,95	887,9	4,54
	1800	11,95	8,27	2054,6	21,04	10,61	7,78	1824,2	16,91	8,07	6,92	1388,5	10,25	5,93	5,68	1020,5	5,83
	2100	13,30	9,32	2286,4	25,51	11,81	8,80	2030,5	20,50	9,00	7,88	1547,2	12,45	6,65	6,35	1143,0	7,16
	2550	15,15	10,82	2605,3	32,27	13,44	10,26	2311,2	25,89	10,29	9,26	1769,7	15,86	7,65	7,30	1316,2	9,22
	3000	16,82	12,22	2892,3	38,94	14,94	11,64	2569,0	31,31	11,47	10,59	1973,1	19,29	8,60	8,17	1478,2	11,37

Entering air temperature: 25°C - Relative Humidity: 50%

Model	WT: 7/12°C					WT: 8/13°C				WT: 10/15°C				WT: 12/17°C			
	Qv m³/h	Pc kW	Ps kW	Qw l/h	Dp(c) kPa	Pc kW	Ps kW	Qw l/h	Dp(c) kPa	Pc kW	Ps kW	Qw l/h	Dp(c) kPa	Pc kW	Ps kW	Qw l/h	Dp(c) kPa
MAC 33	1500	5,97	4,92	1026,0	8,34	5,28	4,75	907,7	6,65	4,05	3,81	697,3	4,10	3,51	3,24	603,8	3,14
	1800	6,67	5,62	1146,4	10,18	5,90	5,46	1015,3	8,14	4,57	4,28	785,4	5,08	3,98	3,65	683,9	3,93
	2100	7,29	6,28	1253,9	11,96	6,47	6,00	1113,3	9,61	5,04	4,70	866,9	6,07	4,40	4,04	757,4	4,72
	2550	8,14	7,22	1399,0	14,57	7,25	6,71	1246,4	11,78	5,69	5,30	978,9	7,55	5,00	4,57	859,5	5,92
	3000	8,87	8,12	1525,8	17,03	7,95	7,35	1367,9	13,92	6,28	5,84	1079,9	9,01	5,53	5,06	951,2	7,11
MAC 34	1500	7,11	5,63	1222,3	6,81	6,25	5,37	1074,0	5,37	4,72	4,48	812,4	3,22	4,10	3,82	704,7	2,47
	1800	7,99	6,49	1373,9	8,40	7,04	6,21	1211,3	6,67	5,36	5,07	921,3	4,04	4,68	4,35	805,0	3,14
	2100	8,79	7,28	1511,7	9,98	7,76	7,00	1333,9	7,93	5,94	5,60	1022,0	4,86	5,22	4,84	897,9	3,82
	2550	9,91	8,42	1704,3	12,38	8,75	8,14	1504,8	9,85	6,74	6,35	1159,7	6,11	5,97	5,52	1027,3	4,86
	3000	10,86	9,50	1867,8	14,60	9,64	8,99	1657,5	11,72	7,49	7,03	1287,5	7,37	6,66	6,15	1145,3	5,92
MAC 36	1500	9,24	6,73	1589,5	13,26	8,13	6,31	1397,3	10,46	6,07	5,57	1044,4	6,14	4,40	4,24	757,0	3,41
	1800	10,55	7,80	1814,5	16,83	9,28	7,33	1595,2	13,28	6,96	6,53	1196,9	7,85	5,08	4,87	873,1	4,41
	2100	11,74	8,81	2019,1	20,39	10,34	8,32	1777,5	16,14	7,78	7,41	1337,8	9,59	5,71	5,46	981,2	5,44
	2550	13,39	10,25	2302,6	25,83	11,79	9,72	2028,2	20,46	8,92	8,47	1534,1	12,26	6,80	6,44	1170,0	7,46
	3000	14,88	11,63	2559,0	31,24	13,12	11,07	2255,4	24,77	9,98	9,46	1716,7	15,02	7,94	7,51	1365,7	9,86

LEGEND

WT = Water temperature
Qw = Water flow

Pc = Cooling total emission
Dp(c) = Water pressure drop

Ps = Cooling sensible emission
Qv = Air flow

Performance data

Cooling emission of MAC Size 4 units

Entering air temperature: 27°C - Relative Humidity: 50%

Model	WT: 7/12°C					WT: 8/13°C					WT: 10/15°C					WT: 12/17°C				
	Qv m³/h	Pc kW	Ps kW	Qw l/h	Dp(c) kPa	Pc kW	Ps kW	Qw l/h	Dp(c) kPa	Pc kW	Ps kW	Qw l/h	Dp(c) kPa	Pc kW	Ps kW	Qw l/h	Dp(c) kPa			
MAC 43	2400	12,24	8,49	2105,5	10,00	10,93	8,21	1879,6	8,12	8,51	7,70	1463,5	5,12	6,49	6,05	1115,3	3,11			
	2900	13,70	9,67	2355,3	12,24	12,23	9,40	2103,1	9,93	9,57	8,85	1645,5	6,33	7,34	6,84	1263,0	3,89			
	3400	14,96	10,77	2572,1	14,34	13,39	10,54	2302,8	11,70	10,54	9,70	1813,2	7,54	8,14	7,56	1399,9	4,69			
	3900	16,13	11,82	2774,4	16,43	14,43	11,60	2481,9	13,38	11,43	10,51	1965,5	8,71	8,87	8,22	1526,0	5,48			
	4500	17,37	13,04	2987,0	18,77	15,62	12,82	2685,8	15,43	12,42	11,38	2136,0	10,12	9,69	8,96	1667,0	6,42			
MAC 44	2400	14,83	10,02	2549,5	9,69	13,23	9,55	2274,4	7,85	10,20	8,69	1753,3	4,87	7,65	7,21	1315,6	2,88			
	2900	16,76	11,51	2881,7	12,07	14,95	11,01	2570,2	9,78	11,59	10,12	1992,9	6,13	8,74	8,22	1502,5	3,65			
	3400	18,48	12,88	3177,5	14,40	16,47	12,38	2831,4	11,64	12,80	11,48	2200,4	7,33	9,72	9,12	1670,8	4,42			
	3900	20,01	14,18	3440,2	16,61	17,87	13,69	3072,6	13,49	13,98	12,78	2404,6	8,60	10,64	9,97	1830,3	5,21			
	4500	21,71	15,68	3732,7	19,24	19,42	15,19	3340,1	15,68	15,23	14,13	2618,3	10,02	11,68	10,92	2008,6	6,16			
MAC 46	2400	17,73	11,55	3048,7	10,57	15,87	10,88	2729,1	8,62	12,27	9,68	2109,3	5,37	9,09	8,64	1563,2	3,10			
	2900	20,29	13,36	3489,2	13,47	18,13	12,63	3117,3	10,95	14,02	11,32	2411,7	6,83	10,44	9,89	1795,3	3,98			
	3400	22,58	15,04	3882,2	16,33	20,17	14,27	3469,0	13,27	15,62	12,89	2686,7	8,30	11,70	11,05	2011,2	4,88			
	3900	24,69	16,63	4245,2	19,18	22,05	15,83	3791,5	15,57	17,13	14,39	2945,1	9,79	12,87	12,13	2212,6	5,80			
	4500	27,03	18,45	4648,6	22,58	24,13	17,64	4150,1	18,32	18,78	16,14	3230,1	11,56	14,19	13,36	2440,4	6,92			

Entering air temperature: 26°C - Relative Humidity: 50%

Model	WT: 7/12°C					WT: 8/13°C					WT: 10/15°C					WT: 12/17°C				
	Qv m³/h	Pc kW	Ps kW	Qw l/h	Dp(c) kPa	Pc kW	Ps kW	Qw l/h	Dp(c) kPa	Pc kW	Ps kW	Qw l/h	Dp(c) kPa	Pc kW	Ps kW	Qw l/h	Dp(c) kPa			
MAC 43	2400	10,87	8,20	1868,8	8,07	9,63	7,93	1656,3	6,46	7,45	6,93	1280,9	4,03	5,65	5,29	970,8	2,43			
	2900	12,16	9,40	2091,7	9,88	10,82	9,13	1860,2	7,97	8,41	7,80	1446,8	5,02	6,42	5,99	1104,0	3,06			
	3400	13,30	10,50	2287,4	11,61	11,88	10,26	2042,9	9,43	9,28	8,58	1596,1	5,99	7,40	6,73	1272,0	3,94			
	3900	14,38	11,55	2472,5	13,36	12,85	11,34	2209,5	10,86	10,10	9,31	1736,8	6,97	8,39	7,62	1443,3	4,95			
	4500	15,54	12,78	2672,9	15,37	13,88	12,57	2386,7	12,47	11,00	10,12	1891,6	8,13	9,54	8,65	1641,1	6,24			
MAC 44	2400	13,14	9,55	2259,8	7,80	11,63	9,09	1999,8	6,23	8,87	8,29	1524,9	3,79	6,59	6,25	1133,9	2,20			
	2900	14,85	11,01	2554,1	9,72	13,16	10,54	2263,7	7,78	10,08	9,45	1734,0	4,77	7,56	7,14	1299,9	2,82			
	3400	16,38	12,38	2816,2	11,59	14,53	11,89	2499,4	9,30	11,19	10,46	1923,8	5,75	8,45	7,95	1452,3	3,44			
	3900	17,78	13,67	3057,1	13,43	15,79	13,19	2715,2	10,80	12,23	11,40	2102,3	6,75	9,27	8,70	1594,3	4,07			
	4500	19,34	15,15	3325,0	15,62	17,20	14,68	2957,7	12,60	13,36	12,45	2297,2	7,92	10,39	9,56	1786,1	4,99			
MAC 46	2400	15,76	10,90	2709,3	8,55	13,96	10,27	2400,4	6,84	10,61	9,14	1823,7	4,13	7,77	7,41	1336,3	2,34			
	2900	18,01	12,65	3097,0	10,87	15,96	11,96	2743,7	8,70	12,15	10,72	2090,0	5,28	8,97	8,52	1542,2	3,03			
	3400	20,05	14,28	3447,5	13,18	17,77	13,55	3056,5	10,57	13,57	12,25	2334,1	6,44	10,07	9,54	1731,1	3,73			
	3900	21,92	15,85	3769,5	15,48	19,45	15,08	3343,9	12,42	14,88	13,72	2559,5	7,61	11,10	10,51	1909,5	4,45			
	4500	24,01	17,62	4129,2	18,24	21,30	16,84	3663,6	14,64	16,37	15,37	2815,3	9,03	12,28	11,60	2111,9	5,33			

Entering air temperature: 25°C - Relative Humidity: 50%

Model	WT: 7/12°C					WT: 8/13°C					WT: 10/15°C					WT: 12/17°C				
	Qv m³/h	Pc kW	Ps kW	Qw l/h	Dp(c) kPa	Pc kW	Ps kW	Qw l/h	Dp(c) kPa	Pc kW	Ps kW	Qw l/h	Dp(c) kPa	Pc kW	Ps kW	Qw l/h	Dp(c) kPa			
MAC 43	2400	9,61	7,90	1653,1	6,47	8,48	7,64	1458,3	5,14	6,51	6,07	1118,6	3,16	5,66	5,18	973,9	2,44			
	2900	10,79	9,10	1854,7	7,96	9,54	8,82	1639,9	6,35	7,37	6,86	1267,8	3,96	6,45	5,87	1109,3	3,08			
	3400	11,82	10,21	2033,0	9,39	10,51	9,66	1807,4	7,56	8,16	7,57	1403,6	4,75	7,17	6,51	1233,7	3,73			
	3900	12,80	11,28	2201,8	10,84	11,39	10,46	1958,2	8,74	8,91	8,24	1531,5	5,56	7,84	7,11	1348,5	4,38			
	4500	13,88	12,54	2386,2	12,53	12,37	11,35	2126,8	10,14	9,73	8,98	1672,7	6,52	8,58	7,78	1475,8	5,16			
MAC 44	2400	11,58	9,08	1991,2	6,21	10,17	8,66	1748,3	4,89	7,68	7,24	1321,0	2,92	6,63	6,18	1140,6	2,22			
	2900	13,10	10,53	2253,4	7,76	11,54	10,07	1984,5	6,14	8,77	8,24	1507,4	3,71	7,66	7,07	1317,0	2,88			
	3400	14,47	11,86	2487,6	9,27	12,78	11,41	2197,2	7,38	9,75	9,15	1677,5	4,50	8,58	7,89	1476,0	3,54			
	3900	15,74	13,14	2706,3	10,78	13,93	12,69	2395,6	8,62	10,68	9,99	1835,8	5,29	9,45	8,67	1625,0	4,21			
	4500	17,12	14,62	2944,2	12,55	15,19	14,08	2611,5	10,07	11,73	10,95	2016,3	6,26	10,41	9,54	1790,0	5,01			
MAC 46	2400	13,90	10,28	2390,1	6,82	12,19	9,68	2096,7	5,36	9,12	8,63	1568,4	3,15	6,66	6,35	1146,1	1,77			
	2900	15,88	11,97	2731,6	8,67	13,96	11,31	2400,0	6,84	10,49	9,93	1803,1	4,05	7,98	7,55	1372,4	2,45			
	3400	17,68	13,55	3041,0	10,52	15,56	12,85	2676,6	8,32	11,75	11,10	2019,8	4,97	9,27	8,76	1594,7	3,22			
	3900	19,37	15,07	3330,8	12,39	17,04	14,34	2930,6	9,80	12,92	12,18	2221,9	5,90	10,56	9,96	1815,8	4,06			
	4500	21,21	16,82	3648,1	14,60	18,72	16,06	3219,6	11,60	14,25	13,39	2450,5	7,03	12,10	11,40	2080,0	5,19			

LEGEND

WT = Water temperature
Qw = Water flow

Pc = Cooling total emission
Dp(c) = Water pressure drop

Ps = Cooling sensible emission
Qv = Air flow

Selection example with SVE fan section

A professional office decides to move in an existing office of about 80 m² to fit-out from an architectural point of view and in terms of installations. The building is provided with a centralised fresh air handling system with the delivery of chilled water at 7°C and hot water at 60°C. The office has two wings exposed to East and West respectively with wide glass windows. As a result, the main thermal cooling load is the summer one. The two zones experience receive the maximum solar gain at different moments along the day, hence the installation of two dedicated conditioning units.

Two zones are served by a central corridor having a lowered false ceiling, as a result it is suitable to use two hydronic conditioners for recirculation, belonging to the MAC range, embedded in the false ceiling. The designer calculates a sensible cooling load of about 5.5 kW per each area and decides, together with the architect, to install some helical diffusers which intake the cooled air at a minimum temperature of 15°C compared to the setpoint temperature of 26°C. Thus, the design conditioning flow rate per each unit is of about 1500 m³/h.

For each unit, a distribution ductwork of supply air is provided towards the different spaces and a simple grid for the return is placed in the false ceiling. It is planned that each supply air circuit, including the ductable silencers will lose about 75 Pa of static pressure. By means of the quick selection tool at page 7, the MAC MOD.2. unit can be selected.

According to the output tables at page 25 it is decided to provide the units with 4-row coil MAC 24 for cooling. Given the reduced winter load, the designer believes that it is necessary to provide an independent 2-row coil MAC 22 for heating purposes.

In addition to the two sections dedicated to the hydronic coil, the MAC unit will be equipped with intake section and supply plenum with the application of a G3 synthetic filter.

Based on the performance and load pressure drop curves of the auxiliary sections at page 14-15, it is supposed that the fan should work at the 3rd speed to reach the required demands and it is possible to estimate a peak consumption of about 300 W, corresponding to a SPI of about 0.2 W/m³/h.

The parameter meets the design energy criteria that the designer had set.

It should be noted that size 3 could be selected as well.

Here below the available selection tools.

Quick selection item

MAC MODEL	Range	Available static pressure range	Absorbed electrical power range
1	600 - 1400 m ³ h	85 - 160 Pa	75 - 240 W
2	1000 - 2100 m ³ h	65 - 195 Pa	135 - 375 W
3	1500 - 3000 m ³ h	100 - 190 Pa	250 - 520 W
4	2400 - 4500 m ³ h	100 - 280 Pa	600 - 1100 W

Emission table: 26°C - UR 50%

		WT: 7/12°C			
MOD.	Qv	Pc	Ps	Qw	Dp(c)
	<i>m³h</i>	<i>kW</i>	<i>kW</i>	<i>l/h</i>	<i>kPa</i>
MAC 24	1000	5,20	3,95	894,3	3,48
	1275	6,09	4,77	1047,8	4,62
	1550	6,85	5,50	1178,2	5,71
	1825	7,54	6,21	1297,1	6,79
	2100	8,18	6,90	1406,3	7,85

Tools to identify the voltage input to reach the air processing performances and the calculation of the absorbed electrical power

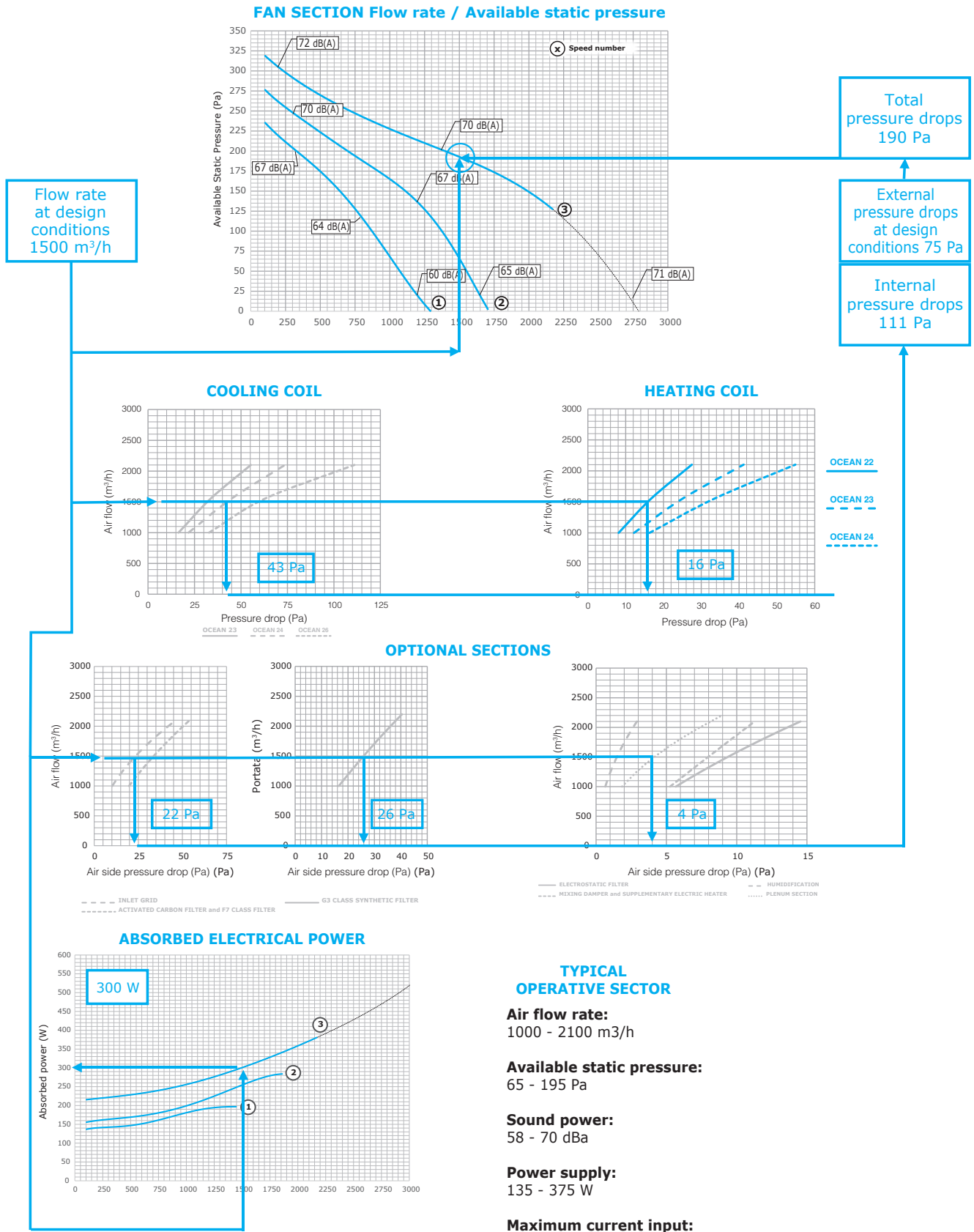

Legend

- Design Input
- Intermediate Outputs / Intermediate Inputs
- Selection Output

Selection example with SVE-ECM fan section

A professional office decides to move in an existing office of about 80 m² to fit-out from an architectural point of view and in terms of installations. The building is provided with a centralised fresh air handling system with the delivery of chilled water at 7°C and hot water at 60°C. The office has two wings exposed to East and West respectively with wide glass windows. As a result, the main thermal cooling load is the summer one. The two zones experience receive the max. solar gain at different moments along the day, hence the installation of two dedicated conditioning units. Two zones are served by a central corridor having a lowered false ceiling, as a result it is suitable to use two hydronic conditioners for recirculation, belonging to the MAC range, embedded in the false ceiling. The designer calculates a sensible cooling load of about 5.5 kW per each area and decides, together with the architect, to install some helical diffusers which intake the cooled air at a minimum temperature of 15°C compared to the setpoint temperature of 26°C. Thus, the design conditioning flow rate per each unit is of about 1500 m³/h. For each unit, a distribution ductwork of supply air is provided towards the different spaces and a simple grid for the return is placed in the false ceiling. It is planned that each supply air circuit, including the ductable silencers will lose about 75 Pa of static pressure. By means of the quick selection tool at page 7, the MAC MOD.2. unit can be selected.

According to the output tables at page 25 it is decided to provide the units with 4-row coil MAC 24 for cooling. Given the reduced winter load, the designer believes that it is necessary to provide an independent 2-row coil MAC 22 for heating purposes.

In addition to the two sections dedicated to the hydronic coil, the MAC unit will be equipped with intake section and supply plenum with the application of a G3 synthetic filter.

Based on the performance and pressure drop curves of the auxiliary sections at page 14-15, we obtain the voltage expected to supply the ECM, which is 8.5 V in order to reach the required demands and it is possible to estimate a peak consumption of about 250 W, corresponding to a SPI of about 0.17 W/m³/h. The parameter is included in the design energy criteria that the designer had set.

Using the table at page 11 regarding sound performance, the reference flow rate for the selected supply voltage ($Q_{rif}=2585$ m³/h) is calculated by interpolation along with the corresponding reference radiated sound power (71.7 dBA). The percentage of the maximum working flow rate compared to the reference one is about 57%. Thus, being included in the graph of page 11, it provides for a reduction of the reference radiated sound power of about 8%, corresponding to a maximum sound power irradiated in the false ceiling of about 66 dBA.

Considering the sound mitigation of the false ceiling and the installation components, the parameter falls within the design noise criteria that the designer had set.

Here below the visual evidence of the selection tools used.

Quick selection item

MOD.	RANGE (m ³ /h)	AVAILABLE STATIC PRESSURE RANGE (Pa)	ABSORBED ELECTRICAL POWER RANGE (W)	MAXIMUM ABSORBED CURRENT (A)	RADIATED SOUND POWER RANGE (dB)
MOD.1	600 - 1400	40 - 160	15 - 200	1,9	45 - 70
MOD.2	1000 - 2100	40 - 200	25 - 370	3,0	50 - 72
MOD.3	1500 - 3000	40 - 250	30 - 600	4,4	50 - 82
MOD.4	2400 - 4500	30 - 270	30 - 950	5,0	60 - 82

Sound selection item

	SPEED									
	10	9	8	7	6	5	4	3	2	1
Q_{rif} (m ³ /h)	2600	2590	2580	2580	2480	2290	2080	1860	1650	1450
$L_{w,rif}$ (dBA)	71,7	71,7	71,7	71,6	71,1	70,1	67,7	65,3	62,4	59,3

$$Q_{des}/Q_{rif} = 1500/2585 = 57\%$$

$$L_{w_MAX} = 92\% * L_{w_RIF} = 0,92 * 71,7 = 66 \text{ dBA}$$

Emission table: 26°C - UR 50%

WT: 7/12°C					
MOD.	Qv	Pc	Ps	Qw	Dp(c)
	m ³ /h	kW	kW	l/h	kPa
MAC 24	1000	5,20	3,95	894,3	3,48
	1275	6,09	4,77	1047,8	4,62
	1550	6,85	5,50	1178,2	5,71
	1825	7,54	6,21	1297,1	6,79
	2100	8,18	6,90	1406,3	7,85

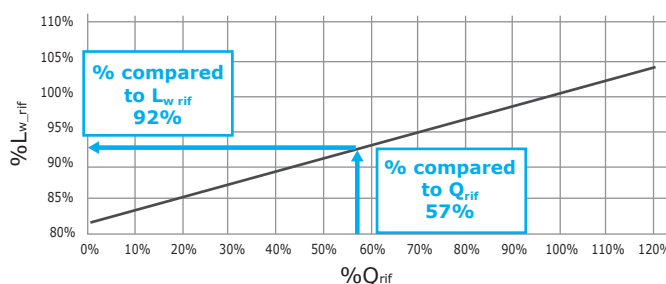

Tools to identify the voltage input to reach the air processing performances and the calculation of the absorbed electrical power

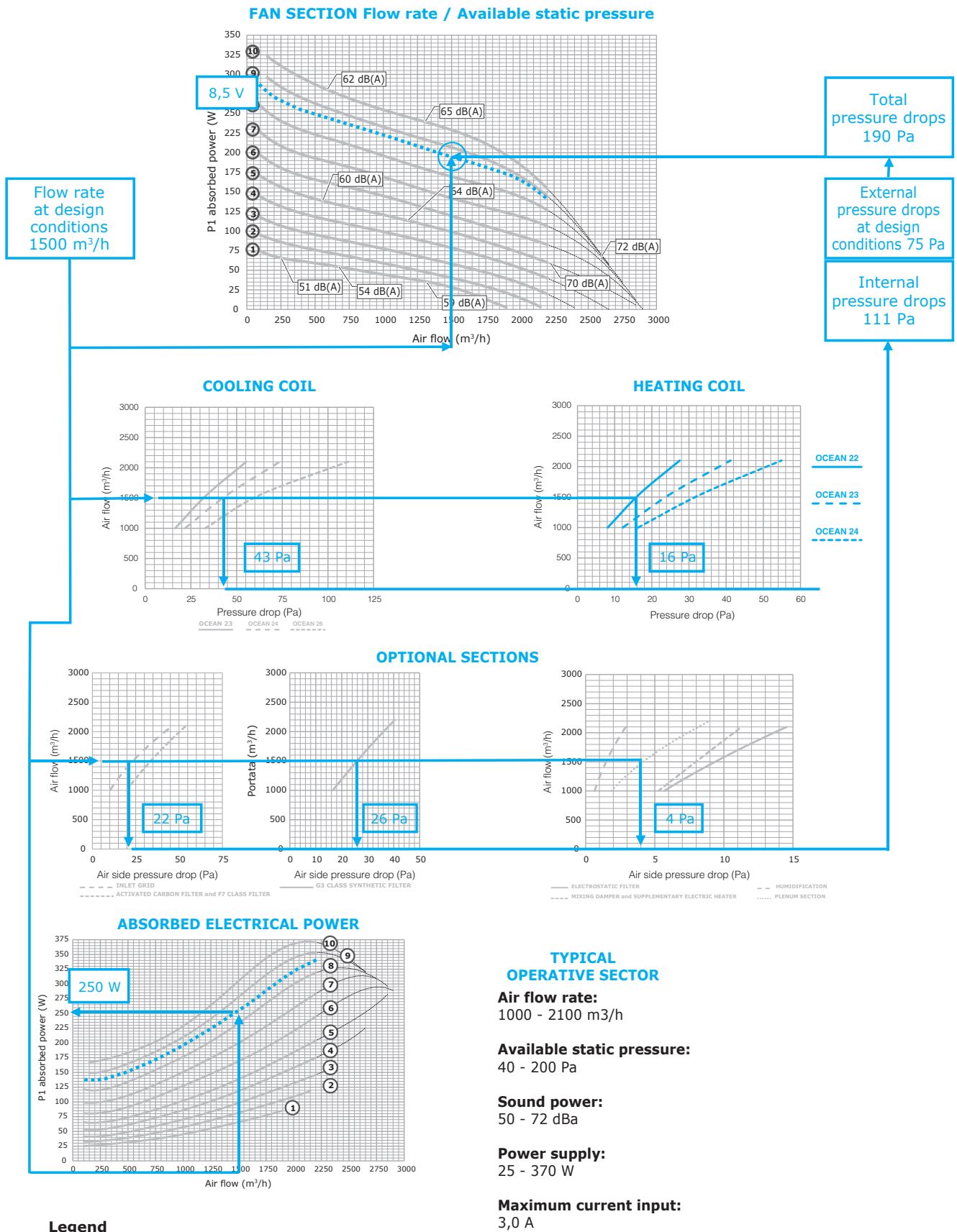

Legend

- Design Input
- Intermediate Outputs / Intermediate Inputs
- Selection Output

Accessories (optional) - Valves

230V ON-OFF Valve Kit

To be used only with 230V ON/OFF controls (QCV-MB, WM-T and WM-TQR)



MOD.	Kvs	Main coil	Auxiliary coil
1	10	9034255	9034255
2	10	9034255	9034255
3	10	9034256	9034255
4	10	9034257	9034257

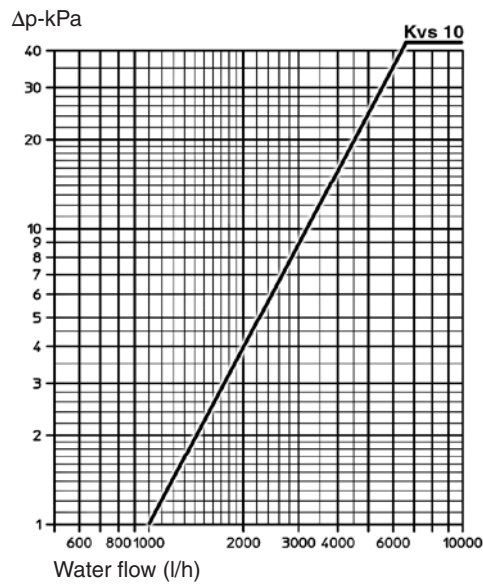

Dimensions

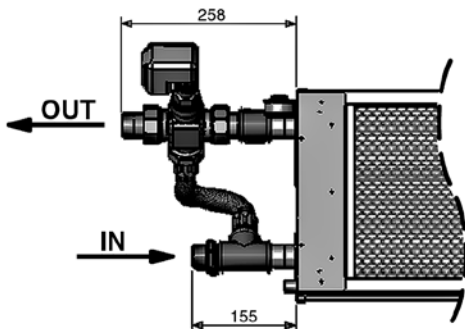

Left connections

Right connections

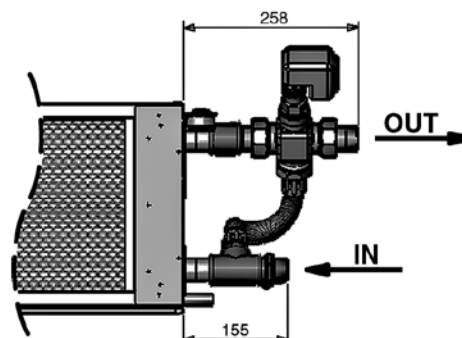

Accessories (optional) - Valves

24V Valve Kit

To be used only with QCV-MB control board

Valve with 3 points - 24 Volt actuator
(the valves can't be used with WM-T and WM-TQR controls)



Mod.	Kvs	Main coil	Auxiliary coil
1	6,3	9034250	9034250
2	6,3	9034250	9034250
3	6,3	9034251	9034250
4	10	9034252	9034252

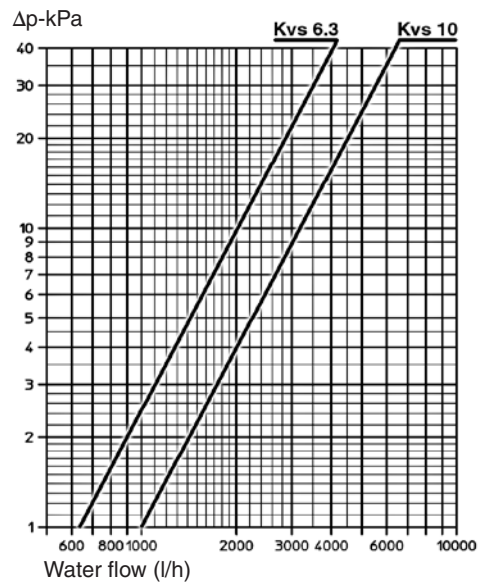

Dimensions

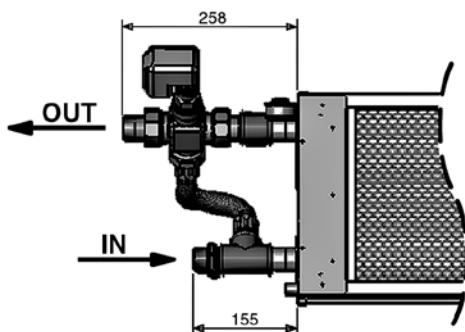

Left connections

Right connections

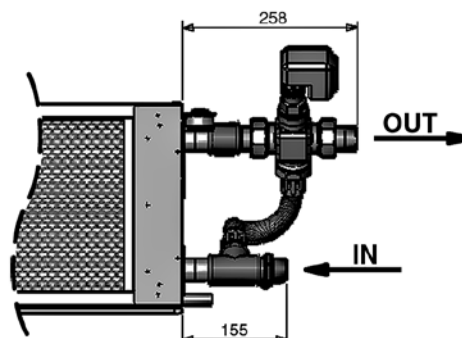

Accessories (optional)

Electrostatic filter and carbon filter

Electrostatic filter

The electrostatic filter matches the need for better air conditioning with the concepts of space and design. With this filter the various stages of air treatment are combined in one appliance.

Thanks to this new patented filter, air pollutants such as cigarette smoke, dust, pollen and most biological organisms are eliminated.

In addition, as fresh air is not being introduced to obtain the best climatic conditions, there are consequential energy savings.

Carbon filter

On request, the carbon filter can also be fitted in the electrostatic filter section. It is highly efficient for the purification of the air from gaseous pollutants and odours.

Operating principle of the electrostatic filter and of the carbon filter

The air is sucked in and first passes a mechanical prefilter, which keeps away particles of more than 50 μm (dust, insects, etc.)
(Phase 1)

Then the smallest particles (50 \div 0.01 μm) are exposed to an intensive ionic field and are polarized.
(Phase 2)

The charged particles passing through the second filter section, are pushed back by the anode and attracted to the collection surfaces by a strong, induced magnetic field.
(Phase 3)

The air which leaves the unit is free from polluting particles.

The carbon filter (supplied on request) purifies the air from gaseous pollutants and from odours.
(Phase 4)

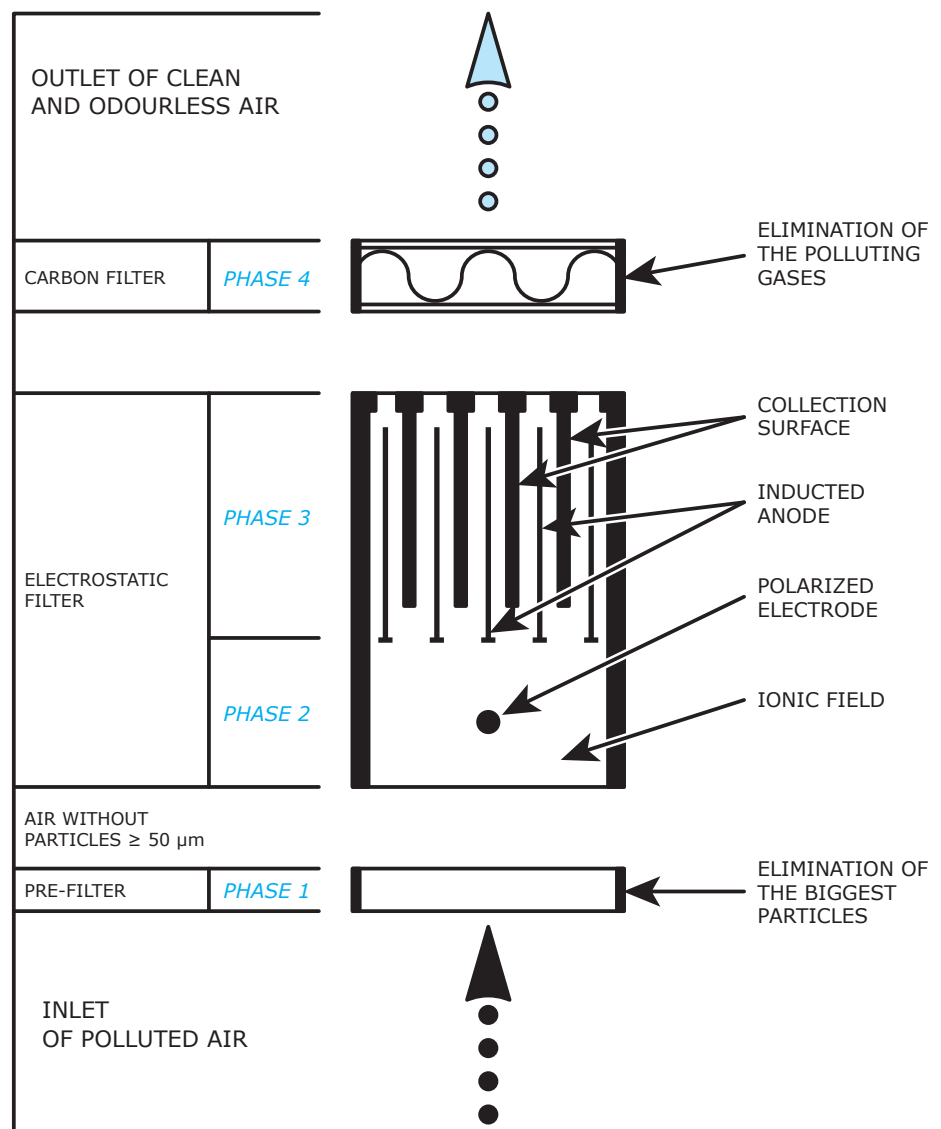

Ventilation and air change

It is generally understood, that the more fresh air introduced indoors the better the indoor air quality will be. However, this implies an increase in energy costs necessary to keep comfortable environmental conditions.

In addition the external air quality must be controlled year round in order to avoid a pollutant concentration that can jeopardize human health, when introduced indoor through ventilation.

The use of the Electrostatic Filter dramatically reduces the external air intake which, in turn, provides a significant energy saving and reduces health risks.

The air treated by an MAC airconditioner fitted with an electrostatic filter usually has a concentration of polluting microparticles lower than the external air concentration, which improves the indoor air quality. The U.S. agencies EPA, OSHA, and the ASHRAE 62-89 Standard set an external air intake minimum value of only 2.5/3L/s per person.

This quantity of external air can guarantee a sufficient salubrity rate for the occupants, provided that there are no specific indoor sources of pollutants (ie tobacco, smoke, special activities).

With these recommended values for external air intake and with an MAC air-conditioner equipped with a suitably sized electrostatic filter, a high quality of indoor air and comfort level can be obtained.

The table below gives a simple indication of the size of the MAC air-conditioner, fitted with the electrostatic filter, required to function efficiently in various installation situations.

Obviously, the large variety of applications and environment situations possible make difficult a more specific and detailed approach to solving particular problems.

This table has therefore, been drawn up on a general basis assuming that certain values remain constant. In particular:

- The pollutant quantity produced indoors is relatively low
- Occupational density is 7p/100 m² (7 people for every 100 m² of surface)
- Ventilation efficiency = 1
- External air quantity < 10% of maximum air flow
- Maximum room height = 3 metres

MAC MODEL	Air flow m³/h	Max room volume m³	Max number of people n°
1	650	160	4
	1000	250	6
	1400	350	8
2	1150	280	6
	1550	380	8
	2100	520	12
3	1750	430	9
	2300	570	12
	3000	750	17
4	2500	620	13
	3800	950	20
	4500	1120	24

Electrostatic filter + carbon filter

"SFE" electrostatic filter section and "FCA" carbon filter

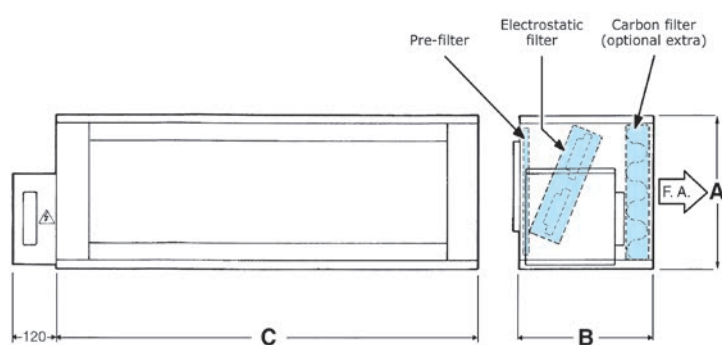

DIMENSIONS				
MODEL	1	2	3	4
A	335	415	515	515
B	300	380	480	480
C	950	950	950	1500
Electrostatic filter	840x112	840x112	840x112	1390x112
Number of electrostatic filters	2	3	4	4
Weight kg	7.8	8.5	10	17

"CIF" remote control

IDENTIFICATION	CODE
CIF	9054043

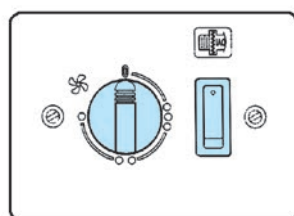

- 3 speed switch.
 - Switch with 4 positions:
 - OFF
 - low speed
 - medium speed
 - high speed
- Electrostatic filter switch.

"WM-TQR" remote control

IDENTIFICATION	CODE
WM-TQR	9066631E

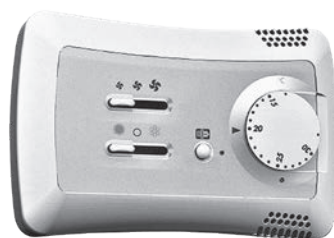

Dimensions: 135x86x31 mm

For models 3 and 4, use the WM-TQR control with the SEL-S speed switch (to be ordered separately).

- ON-OFF switch.
- Manual 3 speed switch.
- Manual, automatic or centralized Summer/Winter switch.
- Electrostatic filter activation switch.
- Electronic room thermostat for fan control (ON-OFF).
- Electronic room thermostat for valve control (ON-OFF).
- Simultaneous thermostatic control of the valves and fan.
- It allows to control the low temperature cut-out thermostat (NTC).
- Energy saving function.
- Presence of a LED signal when the thermostat is on.

Control power absorption: 1 VA

Accessories (optional)

G3 filter section "SFS-G3"

Made of galvanized steel.

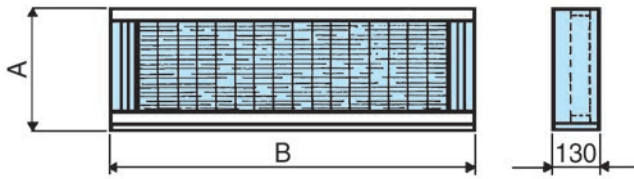

Mod.	1	2	3	4
A	318	398	498	498
B	950	950	950	1500
Weight kg	7.4	7.9	8.4	11.5

Pleated renewable synthetic filter, 48 mm thick

Mod.	1	2	3	4
Class G3 (EN 779:2012)				
Width	870	870	870	1420
Height	290	370	470	470

The standard filter extraction is from the bottom, any different need must be specifically requested.

F7 filter section "SFS-F7"

Made of galvanized steel.

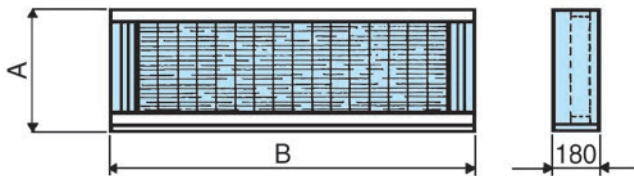

Mod.	1	2	3	4
A	318	398	498	498
B	950	950	950	1500
Weight kg	10.4	11,1	11,8	16,1

Micro-pleated synthetic filter, 98 mm thick

Mod.	1	2	3	4
Class F7 (EN 779:2012)				
Width	870	870	870	1420
Height	290	370	470	470

The standard filter extraction is from the bottom, any different need must be specifically requested.

Condensate collection tray "BRC"

To be used always for combinations from 01 to 06, represented at page 6 and with the "SUD" humidifying section and with chilled water or direct expansion coils.

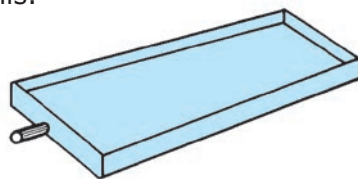

Mod.	1	2	3	4
Weight Kg	2.9	3.9	4.9	7.3

Suspension brackets "SQS"

Galvanized steel angle brackets for either ceiling mounting or wall mounting (included with MAC size 4)

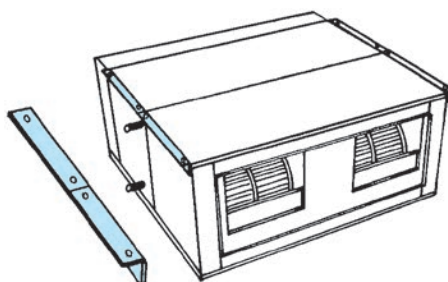

Accessories (optional)

Disposable pack humidification with solenoid valve "SUD"

Humidification section

Deck fill humidification with 2-way valve, powered at 230 V 50 Hz, female gas fitting Ø 1/4", with manual adjustment of the water flow rate. The valve is controlled by a room humidity sensor. Always use the "BRC" condensate collection tray with a siphon on the drain pipe. The maximum water pressure feeding is 2 bars.

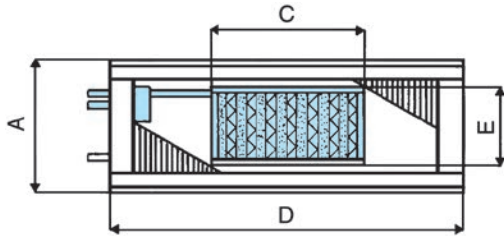

With 1 Coil: Sizes 1-2-3-4

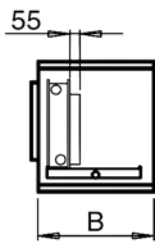

Mod.	1	2	3	4
A	335	415	515	515
B	300	380	480	480
C	480	480	725	1275
D	950	950	950	1500
E	200	200	420	420

With 2 Coils

Size 1 = **SB4+SB2**

Sizes 2-3-4 = **SB4+2**

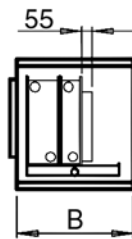
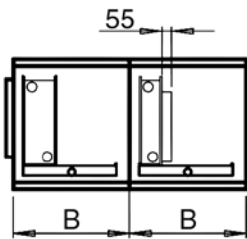

Supplementary electric heater "BEL"

Finned armoured electric heater.

NOTE: the electric heater must be fitted after the fan section.

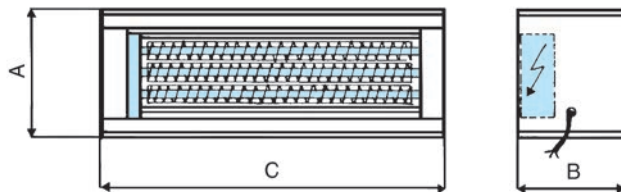

Mod.	1	2	3	4
A	335	415	515	515
B	300	380	480	480
C	950	950	950	1500
Volt	230/1	230/1	400/3	400/3
kW	2	4	6	12
Steps	1	1	3kW+3kW	6kW+6kW
Weight kg	12	14	16	24

Accessories (optional)

Filter section with inlet grid "FGR"

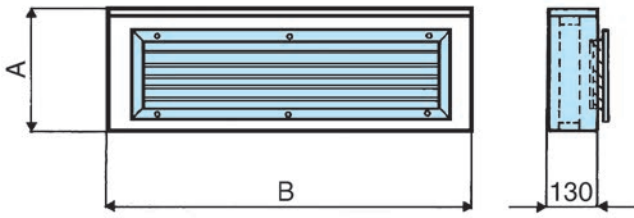

Mod.	1	2	3	4
A	318	398	498	498
B	950	950	950	1500

Filter section with damper "FSR"

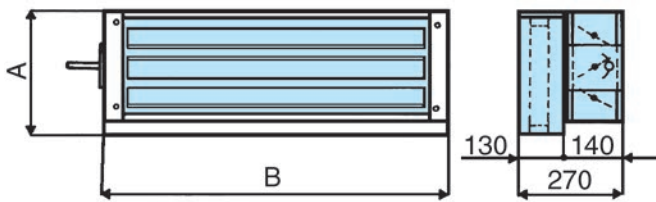

Mod.	1	2	3	4
A	318	398	498	498
B	950	950	950	1500

Inlet box with grid "PAG"

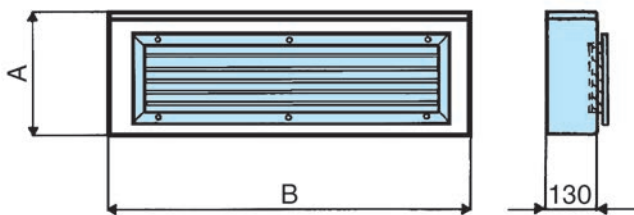

Mod.	1	2	3	4
A	318	398	498	498
B	950	950	950	1500

Inlet box with damper "PAS"

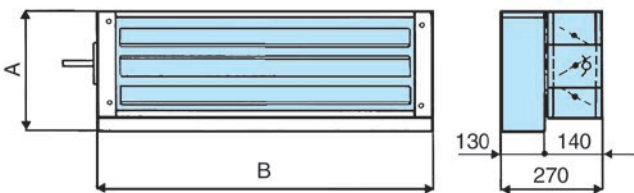

Mod.	1	2	3	4
A	318	398	498	498
B	950	950	950	1500

Inlet/outlet box with top or bottom damper "PMS"

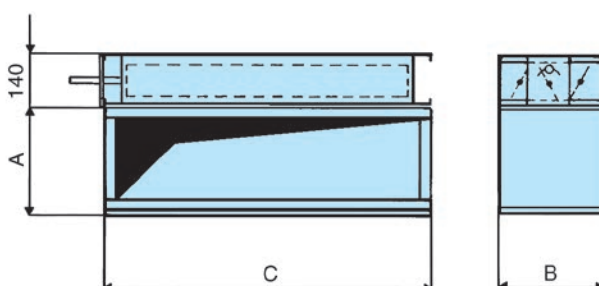

Mod.	1	2	3	4
A	318	398	498	498
B	300	380	480	480
C	950	950	950	1500

Accessories (optional)

Top/bottom panel "PSI"

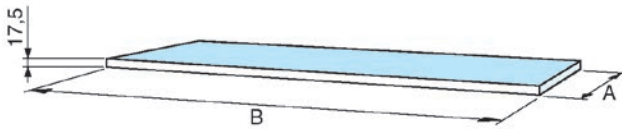

Mod.	1	2	3	4
A	300	380	480	480
B	950	950	950	1500

Mixing box with two dampers "PDS"

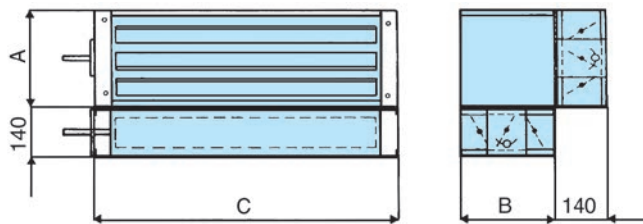

Mod.	1	2	3	4
A	318	398	498	498
B	300	380	480	480
C	950	950	950	1500

Inlet grid "GAS"

to be installed on the ductwork.

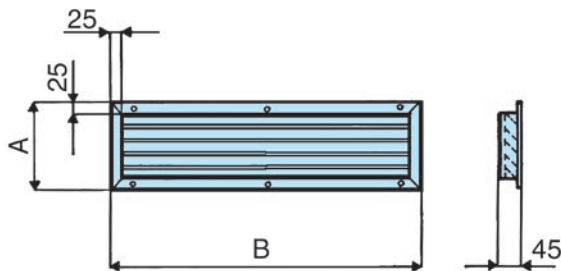

Mod.	1	2	3	4
A	225	325	425	425
B	820	820	820	1380

Panel with inlet grid "PGA"

to be installed on the fan section or on the air box.

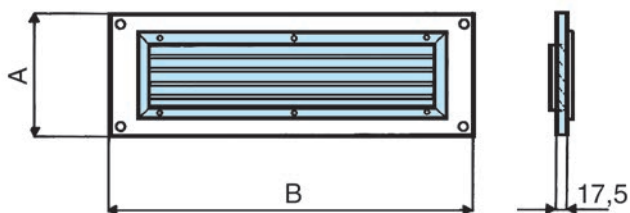

Mod.	1	2	3	4
A	300	380	480	480
B	950	950	950	1500

Inlet damper "SRA"

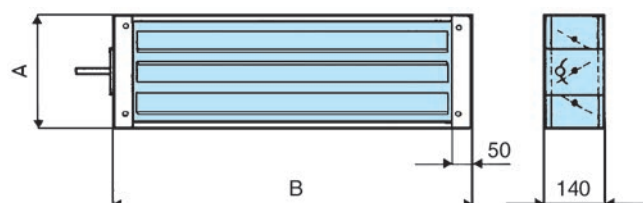

Mod.	1	2	3	4
A	300	380	480	480
B	950	950	950	1500

Accessories (optional)

Outlet box with double louvres "PMB"

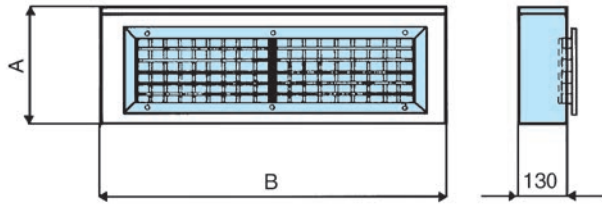

Mod.	1	2	3	4
A	318	398	498	498
B	950	950	950	1500

Outlet box with circular diffusers "PMC"

with 3 circular diffusers (sizes 1-2-3)
with 4 circular diffusers (size 4)

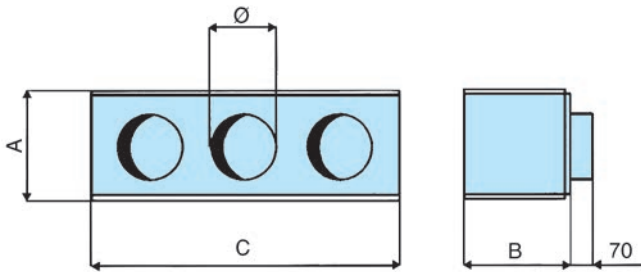

Mod.	1	2	3	4
A	335	415	515	515
B	318	398	498	498
C	950	950	950	1500
Ø	200	200	200	250

Outlet grid "BMA"

Outlet grid with double louvres, to be installed on the ductwork.

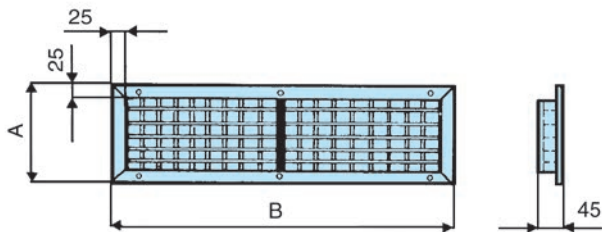

Mod.	1	2	3	4
A	225	325	425	425
B	820	820	820	1380

Wall electronic controls for MAC air conditioners

IDENTIFICATION	CODE
COM	9053022

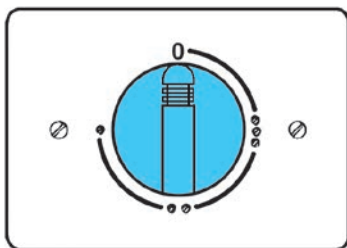

For MAC size 3 and size 4 only

- Speed switch
- Remote manual speed control.
- Switch with 4 positions:
 - OFF
 - low speed
 - medium speed
 - high speed

IDENTIFICATION	CODE
WM-3V	9066642



Dimensions: 75x75x30 mm

For MAC size 1 and size 2 only

- Manual 3 speed switch.
- Without thermostatic control.
- It does not control the valves.

IDENTIFICATION	CODE
WM-T	9066630E



Dimensions: 135x86x31 mm

For models 3 and 4, use the WM-T control with the SEL-S speed switch (to be ordered separately).

- ON-OFF switch.
- Manual 3 speed switch.
- Manual Summer/Winter switch.
- Electronic room thermostat for fan control (ON-OFF).
- Electronic room thermostat for valve control (ON-OFF).
- It allows to control the low temperature cut-out thermostat (TMM).
- It allows to control the chilled water valve (ON-OFF) and the electric heater (BEL) only in case that hot water is not used in winter (otherwise please use WM-TQR control with on/off switch for the electric heater).
- Presence of a LED signal when the thermostat is on.

Control power absorption: 0,25 VA

Wall electronic controls for MAC air conditioners

IDENTIFICATION	CODE
WM-TQR	9066631E



Dimensions: 135x86x31 mm

For models 3 and 4, use the WM-TQR control with the SEL-S speed switch (to be ordered separately).

- ON-OFF switch.
- Manual 3 speed switch.
- Manual, automatic or centralized Summer/Winter switch.
- Electrostatic filter switch.
- Electronic room thermostat for fan control (ON-OFF).
- Electronic room thermostat for valve control (ON-OFF).
- Simultaneous thermostatic control of the valves and fan.
- It allows to control the low temperature cut-out thermostat (NTC).
- It allows to control the water valves (ON-OFF) and the electric heater managed as main heating element or as an integration element.
- Energy saving function.
- Presence of a LED signal when the thermostat is on.

Control power absorption: 1 VA

IDENTIFICATION	MODEL	CODE
VAR	1 - 2	3021051
	3	3021094
	4	9035105 *



Dimensions: 130x130x90 mm

- Electronic variable speed drive with ON-OFF switch.

* With this control it is mandatory to select the relevant special motor in the SVE fan section - Size 4 (Code 0035100X)

Speed switch

IDENTIFICATION	CODE
SEL-S	9079110



Speed switch (Slave)

- It allows to control up to 8 units with only one centralized wall control (1 speed switch for each unit).
- For controls WM-T and WM-TQR.

Wall electronic controls for MAC-ECM air conditioners

IDENTIFICATION	CODE
WM-3V	9066642



Dimensions: 75x75x30 mm

The control must always be connected with ADC-S signal converter (to be ordered separately).

- Manual 3 speed switch.
- Without thermostatic control.
- It does not control the valves.

IDENTIFICATION	CODE
WM-T	9066630E



Dimensions: 135x86x31 mm

The control must always be connected with ADC-S signal converter (to be ordered separately).

- ON-OFF switch.
- Manual 3 speed switch.
- Manual Summer/Winter switch.
- Electronic room thermostat for fan control (ON-OFF).
- Electronic room thermostat for valve control (ON-OFF).
- It allows to control the low temperature cut-out thermostat (TMM).
- It allows to control the chilled water valve (ON-OFF) and the electric heater (BEL) only in case that hot water is not used in winter (otherwise please use WM-TQR control with on/off switch for the electric heater).
- Presence of a LED signal when the thermostat is on.

Control power absorption: 0,25 VA

IDENTIFICATION	CODE
WM-TQR	9066631E



Dimensions: 135x86x31 mm

The control must always be connected with ADC-S signal converter (to be ordered separately).

- ON-OFF switch.
- Manual 3 speed switch.
- Manual, automatic or centralized Summer/Winter switch.
- Electrostatic filter switch.
- Electronic room thermostat for fan control (ON-OFF).
- Electronic room thermostat for valve control (ON-OFF).
- Simultaneous thermostatic control of the valves and fan.
- It allows to control the low temperature cut-out thermostat (NTC).
- It allows to control the water valves (ON-OFF) and the electric heater managed as main heating element or as an integration element.
- Energy saving function.
- Presence of a LED signal when the thermostat is on.

Control power absorption: 1 VA

Wall electronic controls for MAC-ECM air conditioners

IDENTIFICATION	CODE
WM-AU	9066632E



Dimensions: 135x86x24 mm

The control must always be connected with UP-AU power unit (to be ordered separately).

- ON-OFF switch.
- Manual, automatic or centralized Summer/Winter switch.
- Manual or automatic 3 speed progressive switch.
- Summer/Winter/Fan/Auto mode switch.
- Electronic room thermostat for fan control (ON-OFF).
- Electronic room thermostat for valve control (ON-OFF).
- Simultaneous thermostatic control of the valves and fan.
- It allows to control the low temperature cut-out thermostat (NTC).
- Energy saving switch.
- Presence of a LED signal when the thermostat is on.

Control power absorption: see the UP-AU power unit

IDENTIFICATION	CODE
T-MB	9066331E



Dimensions: 110x72x25 mm

The control must always be connected with UP-AU power unit (to be ordered separately).

Wall control with display that allows controlling one or more units in Master/Slave mode. The control is equipped with internal sensor to detect the room temperature, which can be defined as a priority compared to the return air sensor on the fan coil.

The T-MB control features the following functions:

- Switch the unit ON and OFF.
- Temperature set.
- Manual, centralized or automatic Summer/Winter switch.
- Set the fan speed (low, medium, high or autofan).
- Set the operation mode (fan only, cooling, heating, auto).
- Possibility of use of the low temperature cut-out thermostat NTC mounted on the UP-AU power unit.
- Time setting.
- Weekly ON/OFF program.

Control power absorption: see the UP-AU power unit

Wall electronic controls for MAC-ECM air conditioners

DESCRIPTION	IDENTIFICATION	CODE
ADC-S signal converter for wall controls supplied separately	ADC-S	9041072

ADC-S signal converter for WM-3V, WM-T and WM-TQR controls.

It is a signal converter that transforms a 230 volt input in 3/10 volt signal.

This allows the use of 230V wall controls to control the fan speed for inverter motors.

ADC converter is wired between 3 speeds control 230V outputs and the inverter.

According to the ADC wiring, the converter will provide different voltage values ranging between 3/10 volt showed in the wiring diagram.

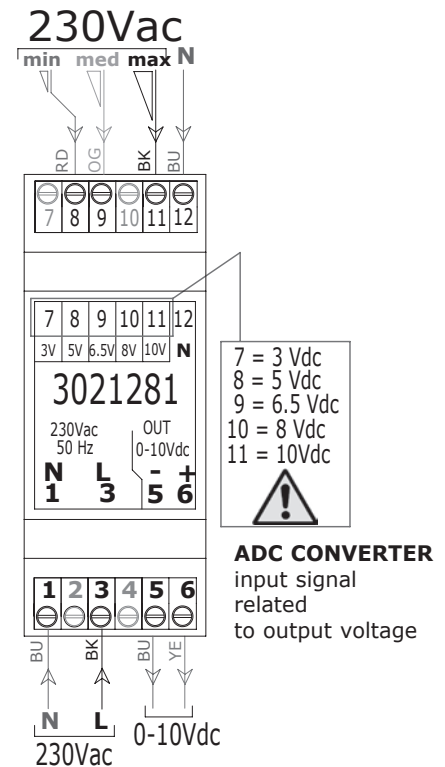

DESCRIPTION	IDENTIFICATION	CODE
Power unit for WM-AU and T-MB wall controls (not fitted on the unit)	UP-AU	9066640



Power unit to be installed on the fan coil (fan coil interface).

- It controls the fan and the valves of the fan coil.
- It is connected to the electric supply.
- It receives the information required from the control.
- Possibility of use of the low temperature cut-out thermostat NTC:
 - T1 function for the return air control.
 - T2 function which controls the summer/winter switch.
 - T3 function as low temperature cut-out thermostat.
- It allows to control up to 10 units (1 master and 9 slaves).
- Max. Network length: 100 meters.
- Max cable length between control and first connected power unit: 20 meters.

Control power absorption: 2,3 VA

Wall electronic control accessories

TMM low temperature cut-out thermostat

IDENTIFICATION	CODE
TMM	9053048

To be installed in contact with the hot water circuit.
For units working on heating only.
To be used with the WM-T control.
It stops the fan when the water temperature is lower than 30°C and it starts the fan when is higher than 38°C.



NTC low temperature cut-out thermostat

IDENTIFICATION	CODE
NTC	3021090

To be fitted between the coil fins.
When connecting the control, the NTC probe cable must be separated from the power supply wires.
To be used with WM-TQR control and UP-AU power unit.
It stops the fan when the water temperature is lower than 28°C and it starts the fan when is higher than 33°C.

To use as:

- T1 function for the return air control.
- T2 function which controls the summer/winter switch.
- T3 function as low temperature cut-out thermostat.



Change-Over CH 15-25

IDENTIFICATION	CODE
CH 15 - 25	9053049

Automatic summer/winter switch
to be installed in contact with the water circuit.
For 2-tube installations only (not to be used with 2 way valve).
To be used with the WM-TQR control.



T2 accessory

IDENTIFICATION	CODE
T2	9025310

T2 sensor to be placed on the water supply pipe upstream 3 way valves (not to be used with 2 way valve).
The **T2** sensor must be used as described below:

- Change-Over for the automatic switch of the operating mode.
If water temperature is lower than 20°C, cooling mode is set; on the other hand, if water temperature exceeds 30°C, heating mode is set.

To be used with the UP-AU power unit.

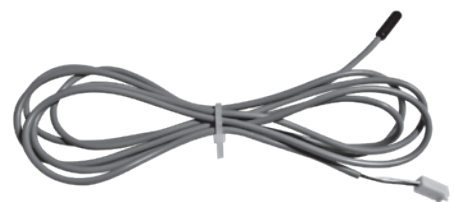

Controls and units MB version

All the **MAC/MAC-ECM** units can be supplied with a wide range of controls, which allows managing one single unit or several units by using the **RTU - RS 485**. Units can be managed according to the Master/Slave logic (up to 20 units) or by supervisory components. The system consists in a **QCV-MB** board with **T-MB** included wall control and a series of controls, such as the **PSM-DI** multifunction control and the **NET** supervisory program.

To be used with valves with 3 points – 24 Volt actuator or with ON/OFF 230 V valves

QCV-MB control board

DESCRIPTION	IDENTIFICATION	CODE
MB version control board for MAC sizes 1-2-3 and MAC-ECM sizes 1-2-3-4	QCV-MB-S 1÷6	9034140
MB version control board for MAC size 4	QCV-MB-S 7	9034147

The **QCV-MB** electronic board is set to carry out different functions and adjustment modes, in order to meet the installation requirements. These modes are selected by setting the configuration dip switches on the board.

- 2/4 pipe system.
- Fan ON/OFF thermostatic control.
- Valve thermostatic control and continuous ventilation.
- Valve and simultaneous ventilation thermostatic control.
- Fan operation control depending on the coil temperature (cut-out T3 probe fitted), which can be activated only in heating mode or heating and cooling mode.
- Automatic switch of the operating mode by means of T2 water probe (optional) applied on the 2 pipe system.
- Seasonal switch by means of remote contact.
- ON/OFF of the fan coil by means of the remote contact (window or clock contact).
- Electric heater control.

By activating the cut-out T3 probe function, the fan is stopped in winter when the coil temperature is lower than 32°C and started when the temperature reaches 36°C. In summer mode, the fan stops when the temperature inside the coil exceeds 22°C and starts when it drops below 18°C.

The following connections are located on the power board:

- T-MB wall control.
- RS 485 serial connection to manage several fan coils in Master/Slave configuration or to create a supervisory network.

T-MB wall control (included with the QCV-MB control board)

Wall control with display that allows controlling one or more units in Master/Slave mode. The control is equipped with internal sensor to detect the room temperature, which can be defined as a priority compared to the return air sensor on the fan coil.

The **T-MB** control features the following functions:

- Switch the appliance ON and OFF.
- Temperature set.
- Modify the set point (when used as a +/- 3° variation of the set point configured from NET supervisory program or PSM-DI).
- Set the fan speed (low, medium, high or autofan).
- Set the operation mode (fan only, cooling, heating; auto for 4 pipe systems with mode selection depending on the air temperature).
- Time setting.
- Weekly ON/OFF program.
- Display and change of the fan coil operation parameters.



Dimensions: 110x72x25 mm

Controls and units MB version

A group of units with **QCV-MB** control board can be connected via a serial link and can consequently be managed at the same time by just one **T-MB** wall control. Using the special jumper present on the board, one unit must be configured as the master, and all the others as slaves.

With T-MB control

One control for each unit

(MAXIMUM LENGTH OF THE CONNECTION CABLE = 20 m)



One control for more units (20 units max.)

(MAXIMUM TOTAL LENGTH OF THE CONNECTION CABLE = 800 m)

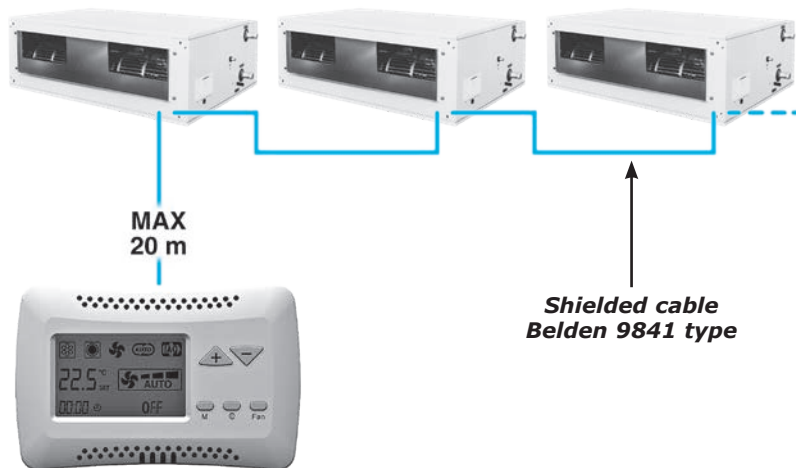

T2 accessory for units with QCV-MB control board

IDENTIFICATION	CODE
T2	9025310

The T2 sensor can be combined with MB boards to be placed on the water supply pipe upstream 3 way valves (not to be used with 2 way valve).

The T2 sensor must be used as described below:

- Change-Over for 2-pipe system for the automatic switch of the operating mode.
If water temperature is lower than 20°C, cooling mode is set; on the other hand, if water temperature exceeds 30°C, heating mode is set.
- It can be used on units with electric heater and hot water supply.
The T2 priority probe activates the electric heater or water valve, depending on the water temperature detected. If water temperature exceeds 34°C, the water valve ON-OFF control is activated; on the other hand, if water temperature is lower than 30°C, the electric heater is activated.

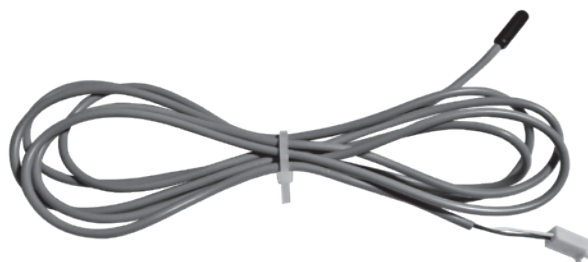

PSM-DI multifunction control panel

DESCRIPTION	IDENTIFICATION	CODE
Multifunction control (to be used with QCV-MB control board only)	PSM-DI	3021293

Another option available for the serial communication between the units is the possibility to connect up to 60 units in series and manage them with just one wall mounted **PSM-DI** controller. The wall mounted controller can be used to set the operating mode for each individual unit connected, display the operating conditions of each individual unit, and set the ON/OFF time sets for each day of the week (the program can be set for all the units and for a maximum of ten groups of units). If more than 60 units need to be connected, two or more controllers must be used. Each unit must have a MB board.

The **PSM-DI** control is used to manage a series of fan coils, up to a maximum of 60 units (the maximum length of the RS 485 connection cable must not exceed 800 m), from one single control point.

The **PSM-DI** control communicates via a serial line with all the units connected, with the possibility of controlling them all together or individually. In fact, the unique address of each individual fan coil means that all the units can be called at the same time, or the individual unit called, to perform the following functions:

- display the current operating mode, the fan speed, the set point;
- display the room temperature measured on the individual unit;
- turn all the units ON and OFF at the same time or alternatively each unit individually;
- change the operating mode (fan only, heating, cooling, automatic changeover);
- change the set point;
- modify the values and operation parameters of the fan speed.

Each function can then be sent to all the units connected, or alternatively to each individual unit.

Different set points or operating modes can be set for each individual unit.

The **PSM-DI** panel can also be used for the time management of the units over the week. Four ON times and four OFF times can be set on the units for each day of the week. A different Temperature set that will be considered as Operation set for all connected appliances, can be set for each event. If the Temperature set is not entered for the individual event, it must be set during programming for each individual unit or for the entire network.

The PSM-DI panel cannot be used together with the NET management program (see next page).

Notes:

- set the configuration Dip Switches as illustrated in the remote control use manual, based on the required solutions.
- only one SIOS board is allowed to be used per each PSM-DI control panel.
- about "Priority pump function": when just one unit calls for, the relay RL1 on the SIOS board is automatically activated to connect a hot water pump.
- the RS 485 network's overall length must not exceed 700/800 metres.

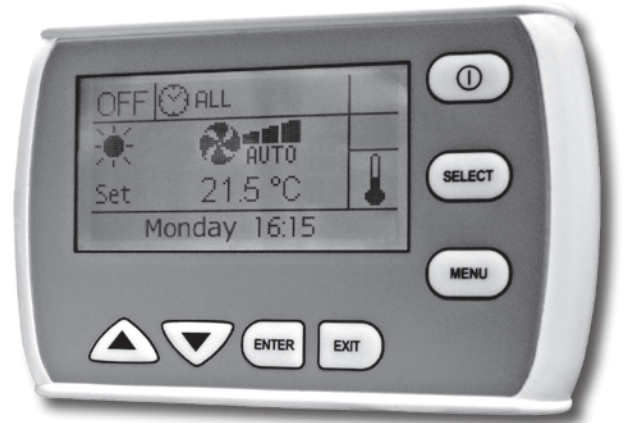

NET program for managing a network of MB fan coils

DESCRIPTION	IDENTIFICATION	CODE
Hardware/software supervisory system (to be used with QCV-MB control board only)	NET	9079118

NET is a centralised control system for networks of MB fan coils, based on software that runs on LINUX™ operating system (the program is provided pre-installed on a PC) and it works in a “stand alone” way, as an ordinary computer, so that it can be connected to a monitor, to a mouse and to a keyboard. By connecting an Ethernet cable is instead possible to work at a distance and visualize the entire program setting-up through whatever browsers.

The **NET** software offers a practical and economical solution for managing the units, with the simple click of the mouse.



The main characteristics include:

- simplicity of use;
- an extremely complete and functional weekly program;
- possibility to access the historical operating data for each individual unit connected;
- possibility to save automatically every 6 h the data on SD support and to force the saving with a switch;
- possibility of data saving also on other items, as for example USB key;
- visualization of the saved configuration on a new ASUS PC:

The program can be used to:

- Create uniform groups (groups of units on individual floors, in offices or rooms).
- Save weekly programs configured for different types of operation (summer, winter, mid seasons, closing periods etc.); these can then be recalled and activated with a simple click of the mouse. Weekly on/off cycles can be set for individual units or groups of units.
- Set the operating conditions for each individual unit or groups of units (operating mode, fan speed, temperature setting).
- Set the set point limits for each individual unit or groups of units.
- Switch each individual unit or groups of units ON or OFF.

The main program screen can display and interact with the entire network of units. An individual unit, a group of units or the entire network can be called so as to make modifications to the operating mode and the set point. The user can then check the operating status of each individual unit, read the room temperature, the coil temperature and the operating status of the condensate drain pump or any alarms.

"MONITORING" SCREEN







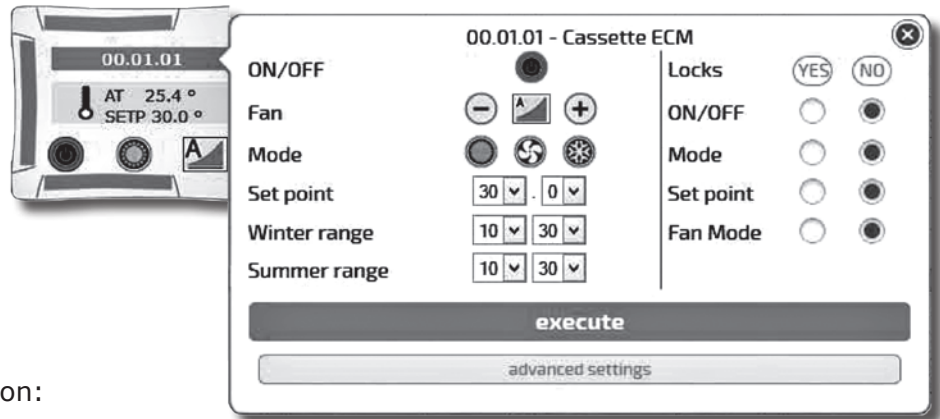





Displaying a unit

The **"MONITORING" SCREEN** shows the units that are connected to the network and scanned by the program.



The icon of the terminal unit provides the following information:

- Unit name (**00.01.01**)
- Set temperature (**SETP**)
- Room temperature (**AT**)
- Unit status: ON (Green)  o OFF (Red) 
- Mode:
 -  Summer
 -  Winter
 -  Auto
 -  Fan only
- Fan speed:
 -  Low
 -  Medium
 -  High
 -  Auto Fan

The "Weekly Program" can be used to set the unit operating parameters for each day of the week. Several weekly programs can be set.

"EVENT MANAGEMENT" SCREEN

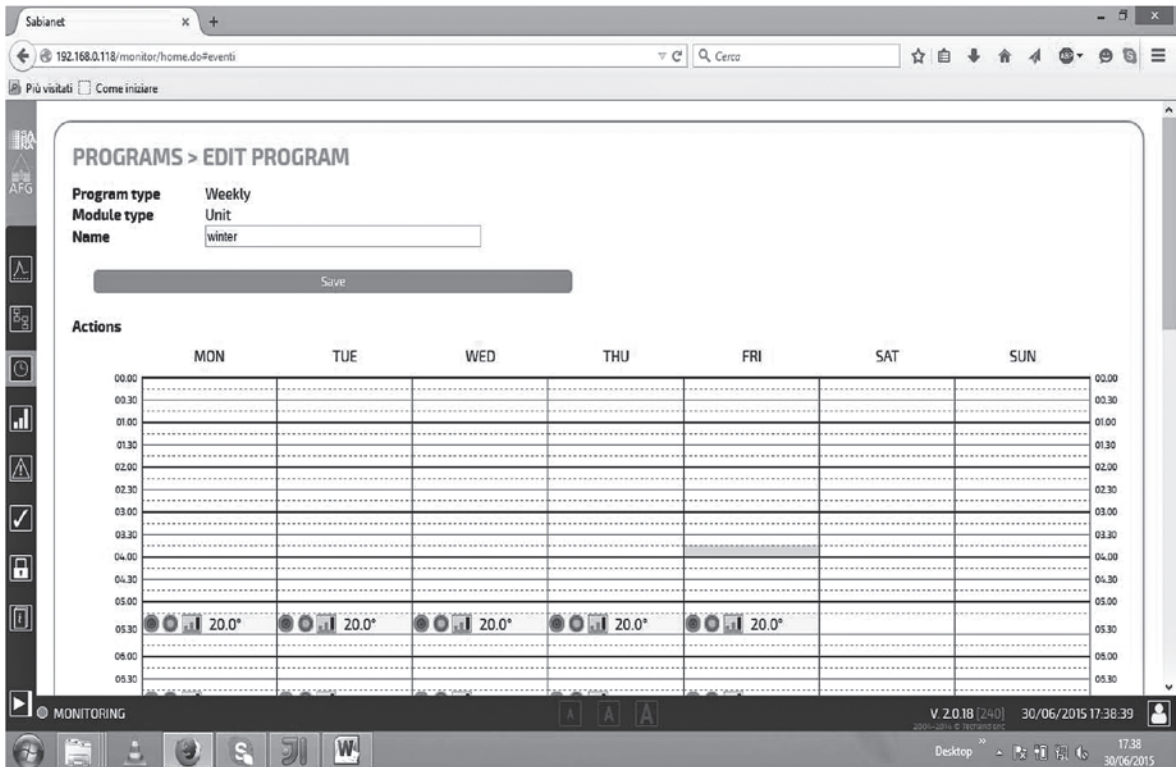

Time bands are available for each day of the week. The time and the type of operation to be performed by the unit can be set for each band. The time and the operating parameters can then be displayed before being sent to the unit and implemented.

Management system for a network of fan coils

Displaying of the parameters and Dip Switches set up

Every time that the reading of the set up Dip Switches results not easy (as for example by the false ceiling installations), it is always possible to display them directly through the NET program.

Group: gruppo 1	FW release: 0.50	Program: gruppo 1 inverno
Remote control: N.A.	M/S network: N.A.	Unit tree: Level 2 --> Router 1
Unit status: ON	Mode: WINTER	Fan mode: AUTO
Set Point: 22.0°	Heating status: OFF	Fan status: OFF
T1: 22.5°	T2: N.A.	Cooling status: [OFF]
Pump: YES	Remote ON/OFF input: OFF	Inverter voltage: 0.2
	Window input: OFF	

Unit settings		Alarms
Dip Switch:	OFF ON	
<input type="checkbox"/> 1	2 pipe unit	T1 Fault OFF
<input type="checkbox"/> 2	Thermal station with valves	T2 Fault OFF
<input type="checkbox"/> 3	T3 disabled	T3 Fault OFF
<input type="checkbox"/> 4	T3 only winter when enabled	
<input checked="" type="checkbox"/> 5	Simultaneous ventilation of valves	Condensation OFF
<input type="checkbox"/> 6	Unit without electrical heater	
<input type="checkbox"/> 7	T2 as CH Change-over (resistance phase II)	
<input type="checkbox"/> 8	UNIT ALERT	
<input type="checkbox"/> 9	Remote ON/OFF input	
<input type="checkbox"/> 10	MASTER	

Alarm control by E-mail and sms

In addition to the alarm set on the NET display, it is possible to send the ON-OFF alarm notification via E-mail and sms.

ALARMS

Ongoing alarms

At	Address	Unit name	Group	Alarm type
No alarms				

Alarms log

From	To	Address	Unit name	Group	Alarm type
No alarms					

Notification

Event type	eMail					SMS				
	none	instant	after 1 hour	after 3 hours	at the end	none	instant	after 1 hour	after 3 hours	at the end
Alarm on unit [any]	<input checked="" type="radio"/>	<input type="radio"/>	<input type="radio"/>	<input type="radio"/>	<input type="checkbox"/>	<input checked="" type="radio"/>	<input type="radio"/>	<input type="radio"/>	<input type="radio"/>	<input type="checkbox"/>
Condensate alarm on unit	<input checked="" type="radio"/>	<input type="radio"/>	<input type="radio"/>	<input type="radio"/>	<input type="checkbox"/>	<input checked="" type="radio"/>	<input type="radio"/>	<input type="radio"/>	<input type="radio"/>	<input type="checkbox"/>
Probe alarm on unit	<input checked="" type="radio"/>	<input type="radio"/>	<input type="radio"/>	<input type="radio"/>	<input type="checkbox"/>	<input checked="" type="radio"/>	<input type="radio"/>	<input type="radio"/>	<input type="radio"/>	<input type="checkbox"/>

Save

RS 485 serial connection cable

Shielded cable to be used:

Belden 9841, RS-485, 1x2x24 AWG SFTP, 120 Ohm

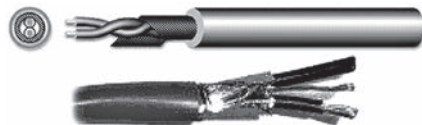

PC NET Software

Connection of a MAC network with QCV-MB control board

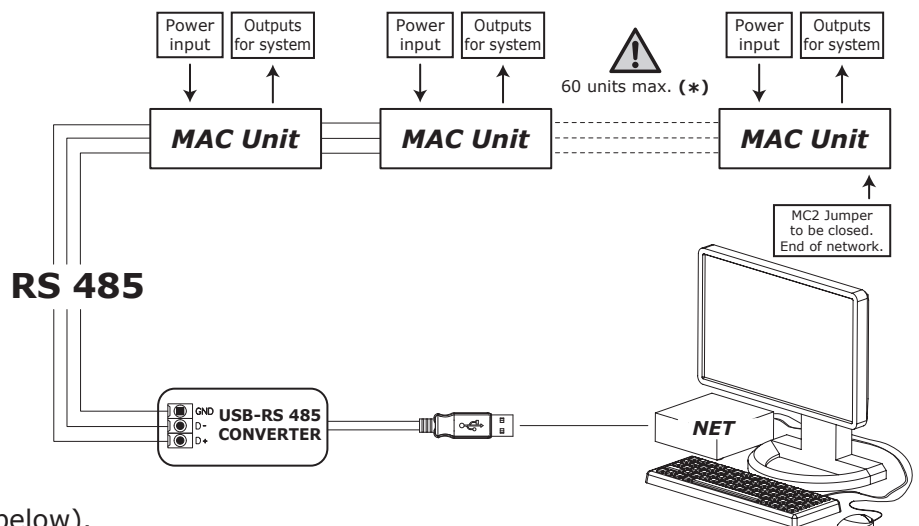

(*) In the event of more than 60 units, add one or more Router-S (see below).

PSM-DI and NET electronic boards

IDENTIFICATION	CODE
<i>SIOS</i>	<i>3021292</i>

SIOS is a board equipped with 8 relays with potential free contact to control the activation or deactivation of remote electric utilities. Moreover, the board has 8 digital inlets to display the actuators or external consents, such as motor or other.

The SIOS boards can be connected:

- inside a network managed by NET;
- to a PSM-DI panel (one SIOS for each PSM-DI panel).

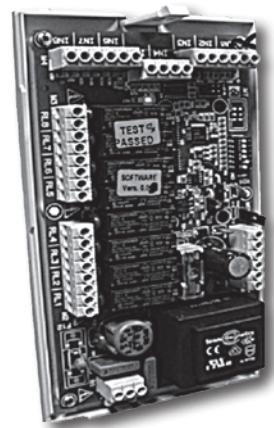

IDENTIFICATION	CODE
<i>Router-S</i>	<i>3021290</i>

The Router-S is an electronic board that allows to control several units inside a network managed by NET (default) or within a sub-network managed by BMS systems, that are not provided (it is necessary to operate on a Dip Switch on the board).

Managed by NET

The Router-S in the standard version is an electronic board that:

- allows creating networks with more than 60 units (minimum 2 Router-S are required) or to divide the network (per floor, building, etc.);
- allows creating a Master/Slave sub-network to be controlled as an independent group.

The number of Router-S to be used is:

- up to 60 units: no Router-S
- from 61 to 120 units: 2 Router-S
- every 60 subsequent units: 1 additional Router-S

Managed by BMS Systems which are not provided

The Router-S becomes an electronic board to use with BMS systems not supplied, only after having set the Dip Switch on the board and so creating a Master/Slave sub-network to be controlled as an independent group.

The number of Router-S to use is:

- maximum 14 Router-S.
- maximum 15 fan coils per Router-S.

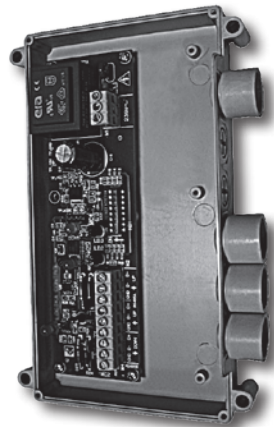

**The descriptions and illustrations provided in this publication are not binding:
we reserve the right, whilst maintaining the essential characteristics
of the types described and illustrated, to make, at any time,
without the requirement to promptly update this piece of literature,
any changes that it considers useful for the purpose
of improvement or for any other manufacturing or commercial requirements.**

