



Ocean ECM

Double insulated panel fan coil

Ocean ECM

Double insulated panel fan coil modular version



The **Ocean ECM** ceiling double insulated panel fan coils are suitable for heating and cooling small and medium-sized environments.

It is the most comprehensive range, perfectly suited to meet all of the climate control needs of work environments such as offices, shops, restaurants and hotel rooms featuring ducted installations with high available pressure.

5 sizes are available (from 600 to 4.600 m³/h), each one equipped with synchronous permanent magnet brushless electronic motor and inverter board, 3 - 4 - 6 row coils. It is also possible to mount either an additional section of 1 - 2 row coil for 4 pipe systems. All the units are constructed with single sections that can be easily assembled to satisfy any installation need.

Casing consists of self-supporting insulated panels with internal insulation of 30 kg/m³ expanded polystyrene 22 mm thick. The panels are made inside of galvanized steel and of pre-painted galvanized steel plate RAL9006 outside.

Fixing blocks. The modular sections can be easily assembled by means of fixing blocks that quickly and precisely hold together the different sections. All the modular sections are equipped with fixing blocks preassembled on the casing.

Fan assembly consists of centrifugal fans with plastic blades directly keyed on the motor with double aspiration.

Motor. It is a synchronous three phase permanent magnet brushless electronic motor controlled with BLAC technology. The inverter board that controls the motor generates a frequency modulated, wave form power supply. The electric power supply required: 230 V.

Coil. It is manufactured from drawn copper tube and the aluminium fins are mechanically bonded onto the tube by an expansion process.

The modular units are available with:

- Heating coil section with 2 or 3 rows for 2 pipe system
 - Cooling coil section with 3, 4 or 6 rows for 2 pipe system
 - Heating and cooling coil section for 4 pipe system with 1 or 2 row coil for heating and 3, 4 or 6 rows for cooling
- Threaded coil male connections.

Filter available in the following versions:

- G0
- ePM₁₀ 50% (ex G4)
- ePM₁ 55% (ex F7)

Condensate collection tray made of steel painted with epoxy polyester coat, dried in a furnace at 180 °C. The diameter of the condensate discharge pipe is 15 mm.

Available modular components

- Fan section
- Single or double coil section
- G0 filter section
- ePM₁₀ 50% (ex G4) class filter section
- ePM₁ 55% filter class (ex F7)
- Additional coil section for 4 pipe system (to be used with the compact section when the additional coil is required)
- Heating electric coil section
- Disposable pad humidification section
- Steam pad humidification section with fitted steam nozzle and steam generator separately delivered
- Section with damper
- Crystall section

SVE-DP Fan section

The fan section is made of an internal structure of double insulated panels and fan deck with brushless fan/motor assembly. The electrical connection is reported within the electrical box on the section side.

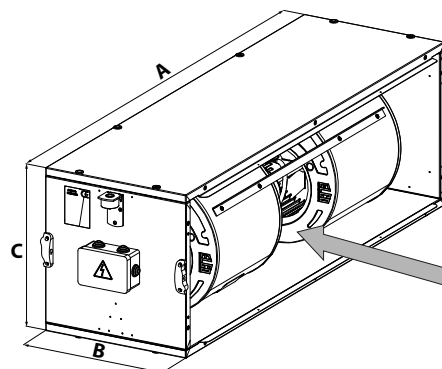

SBC Heating coil section

The SBC section is for heating only and is available with 2 or 3 row coil

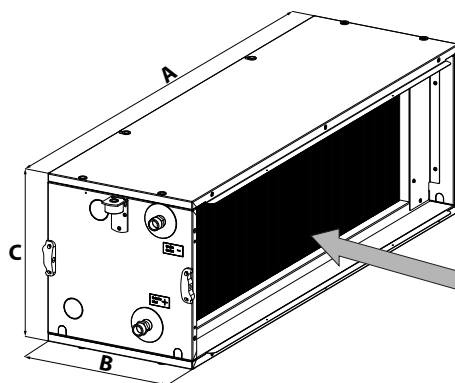

SBF Cooling coil section

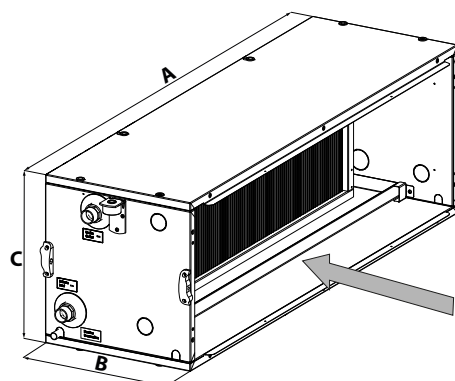

SBCF Heating + cooling coil section

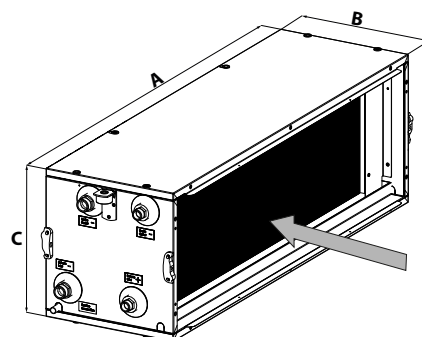

SBVF Coil section for vertical installation

The SBVF coil section must be always installed upstream of the SVE-DP fan section (regarding the air flow). The coil section for vertical installation is suitable for:

- 3 or 4 row cooling/heating coil for 2 pipe system
- 6 row only for cooling coil for 2 pipe system

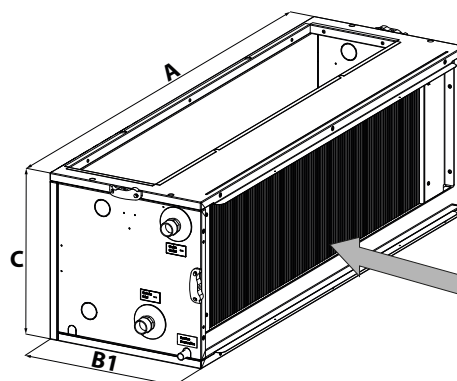

SFS Filter section

The filter section is available into three variants:

- with G0 filter
- ePM₁₀ 50% filter class (ex G4)
- ePM₁ 55% filter class (ex F7)

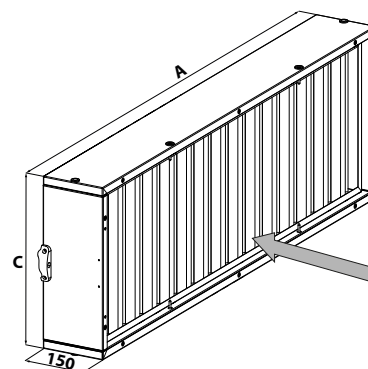

SFE-DP Crystall section

Section with Crystall plate type electrostatic filter

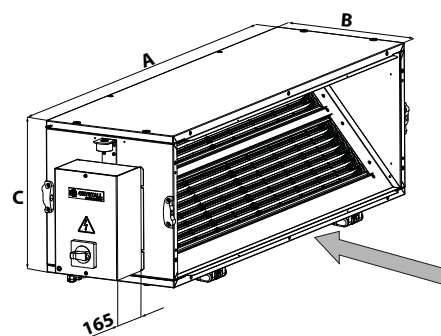

Model	A mm	B mm	B1 mm	C mm
1	1165	370	390	325
2	1165	370	390	325
3	1165	370	390	390
4	1485	440	460	390
5	1485	440	460	450

SUD-DP **Humidification section**

made of cellulose honeycomb pad imbued with waterproof resins, frame and distributor that is linear on the upper part. The pad is 100 mm thick and it is of disposable type. The section is equipped with water collection tray.

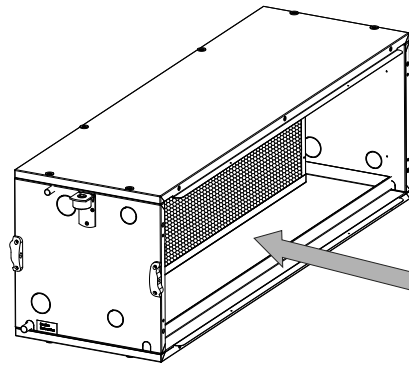

SB2UD **2 row heating coil + humidifier**

The 2 row heating coil section + humidifier includes within a single module a 2 row coil and a humidification pad. The 2 row coil must be used for heating only.

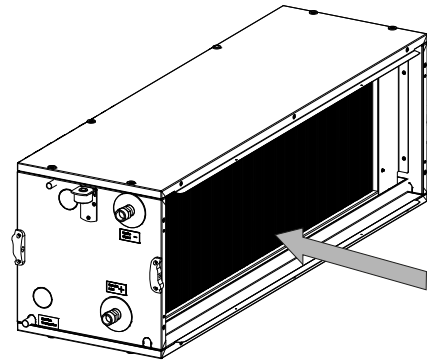

SUD-V **Steam humidification section**

The steam humidification section includes a module with steam nozzle fitted on the unit, to be used only with stand-alone steam generators (not to be used with steam network). The section includes a condensate collection tray.

The steam nozzle is made of stainless steel with:

- upper steam outlets
- condensate return
- 22 mm diameter for the sizes 1 - 2 - 3 and 30 mm for the sizes 4 - 5

The steam generator is not supplied

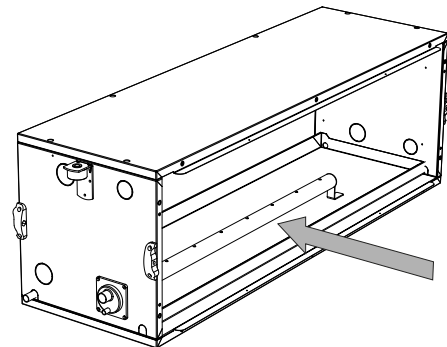

SBEL **Electric coil section**

It consists of a series of armoured electric heaters with an aluminium "Y"-shaped form with a high exchange surface, with a safety thermostat with automatic reset and another one with manual reset. The whole section is provided with a control board.

Available versions::

- Single-phase version: 230 Vac / 1 Ph / 50 Hz
- Three-phase version: 400 Vac / 3 Ph / 50 Hz

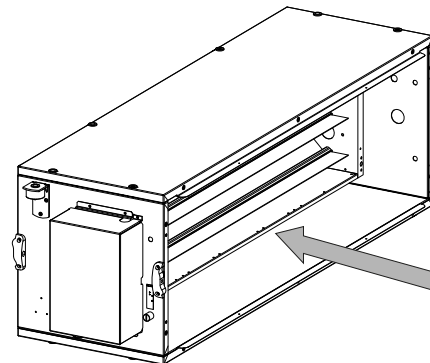

SPS Plenum section with dampers

It allows to calibrate and mix the exhausted air and the fresh air flows properly.

Available versions:

- Plenum with back and lower damper - **SPS-P-I**
- Plenum with back damper - **SPS-P**
- Plenum with lower damper - **SPS-I**

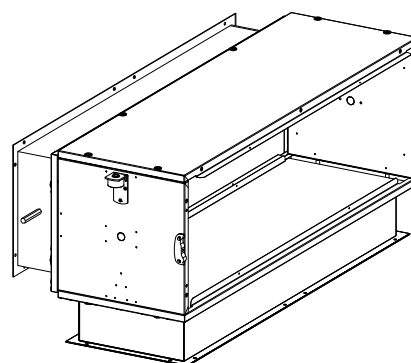

SXS Silencer section

The silencer section can be installed either for the air inlet and the air outlet. It allows a sensible reduction of the noise generated by the unit by means of sound-absorbing materials made of 30 kg/m³, 50 mm thick reinforced glass fibre on both sides, with a black thin layer against the exfoliation.

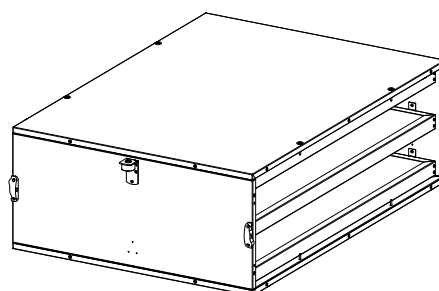

SLG Germicidal lamp section

The germicidal lamp section is useful for the sanitization of the surfaces potentially wet, like the cooling coils with dehumidification and humidification sections. The lamps are installed within the section.

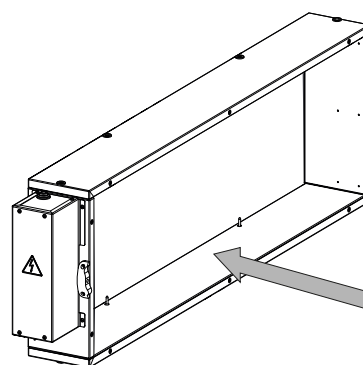

In addition to the available versions using standard components (fan/motor section, coil section and filter section), a wide range of further combinations can be achieved and for each of them you can choose between the five different types of coil.

Horizontal modularity

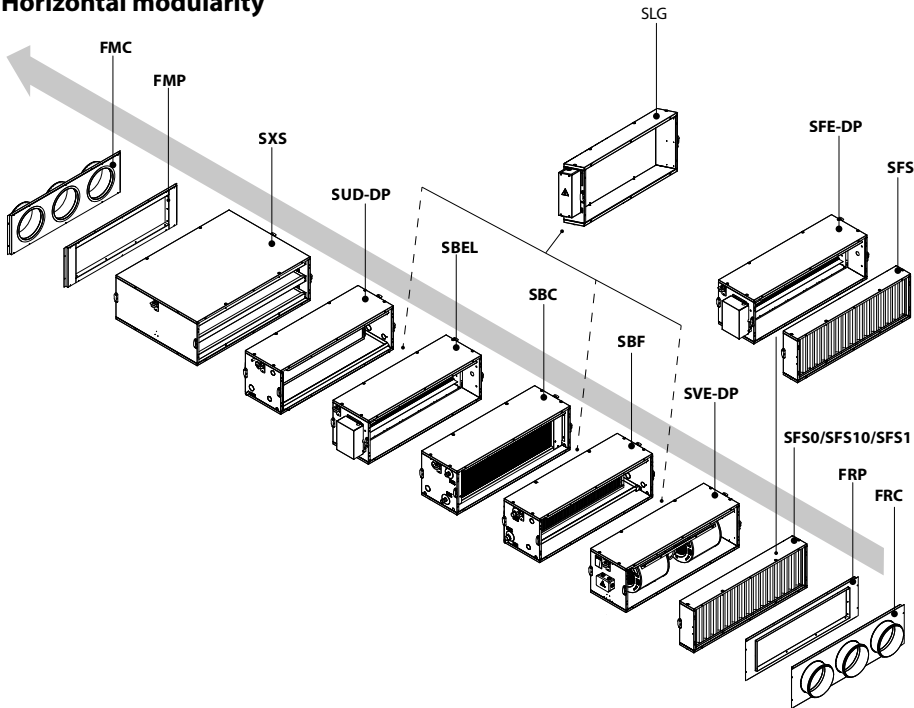

- FRC Air return flange with circular spigots
- FRP Air return flat flange
- SFS0 G0 filter section
- SFS10 Filter section class ePM₁₀ 50% (ex G4)
- SFS1 Filter section class ePM₁ 55% (ex F7)
- SFE-DP Crystall section
- SFS Filter section
- SVE-DP Fan section
- SBF Cooling coil section
- SLG Germicidal lamp section
- SBC Heating coil section
- SBEL Electric coil section
- SUD-DP Humidification section
- SXS Silencer section
- FMP Air supply flat flange
- FMC Air supply flange with circular spigots

⚠ SUP-DP humidification section always downstream of the SBC heating coil or SBEL electric coil

Vertical modularity

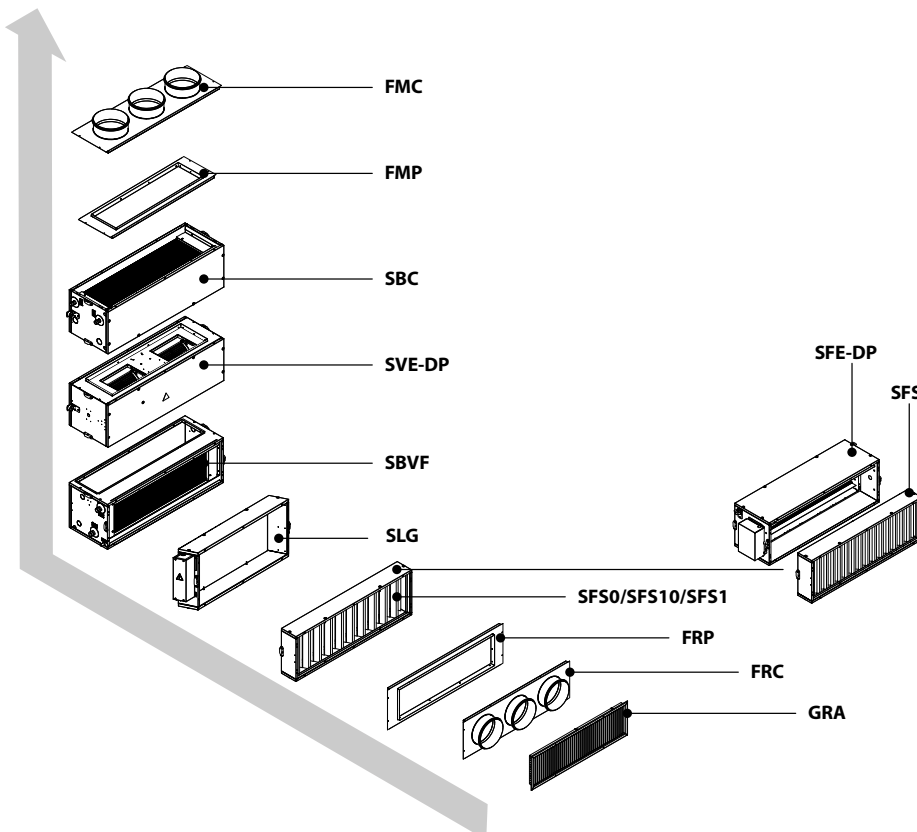

- GRA Air intake grid
- FRC Air return flange with circular spigots
- FRP Air return flat flange
- SFS0 G0 filter section
- SFS10 Filter section class ePM₁₀ 50% (ex G4)
- SFS1 Filter section class ePM₁ 55% (ex F7)
- SFS Filter section
- SFE-DP Crystall section
- SLG Germicidal lamp section
- SBVF Coil section for vertical installation
- SVE-DP Fan section
- SBC Heating coil section
- FMP Air supply flat flange
- FMC Air supply flange with circular spigots

⚠ In the vertical composition neither the SUD-DP humidification section nor the SBEL electric coil can be installed

Model 1

Typical fan curves related to the various voltage supplies of the inverter board.

Flow rate/ Available static pressure

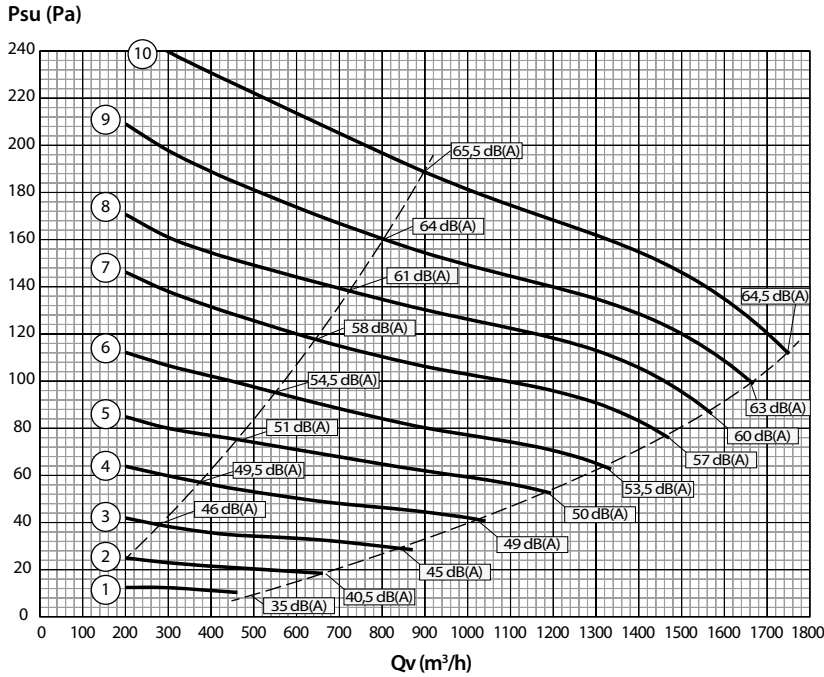

(X) = control voltage
 Psu = available static pressure
 Qv = flow rate
 dB(A) = global sound power

Absorbed electrical power

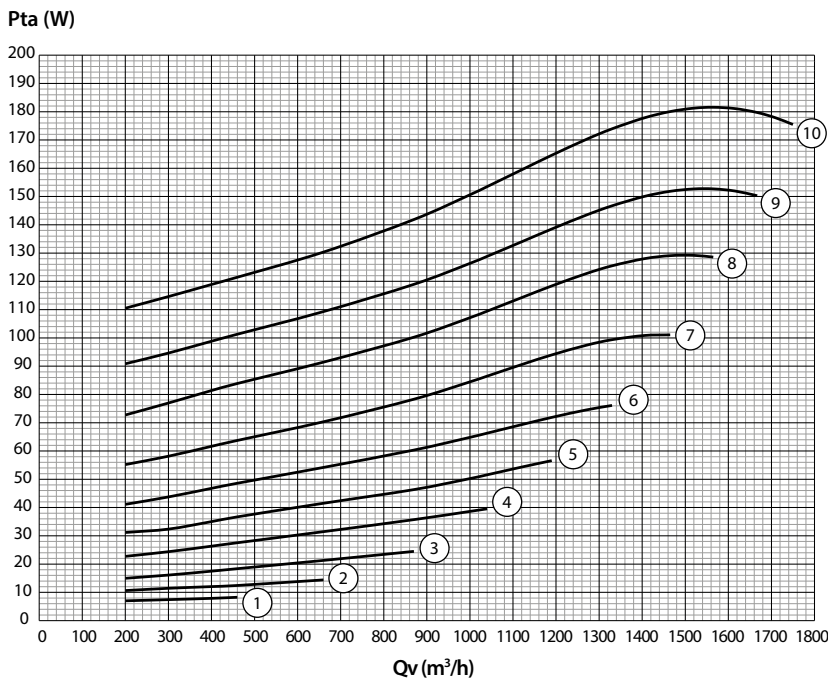

(X) = control voltage
 Pta = absorbed electrical power
 Qv = flow rate

Model 2

Typical fan curves related to the various voltage supplies of the inverter board.

Flow rate/ Available static pressure

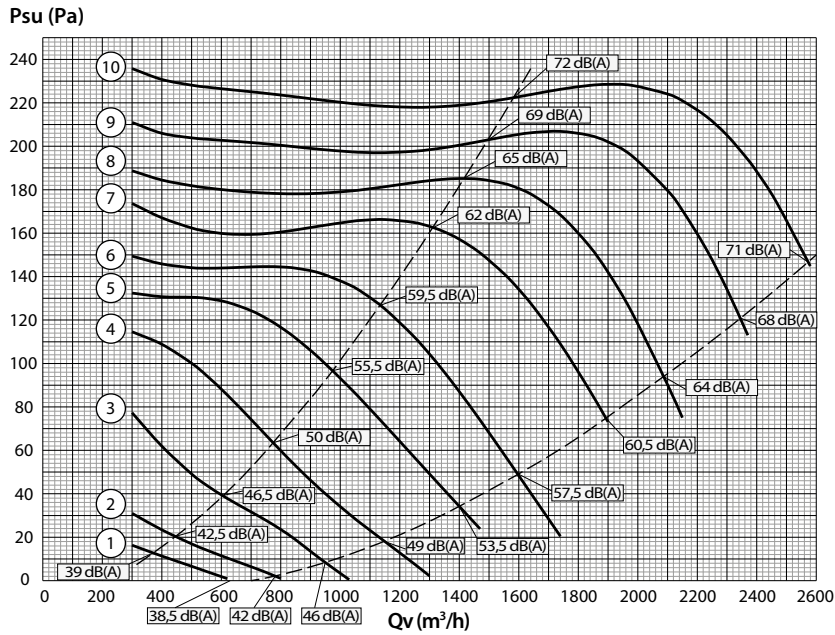

Absorbed electrical power

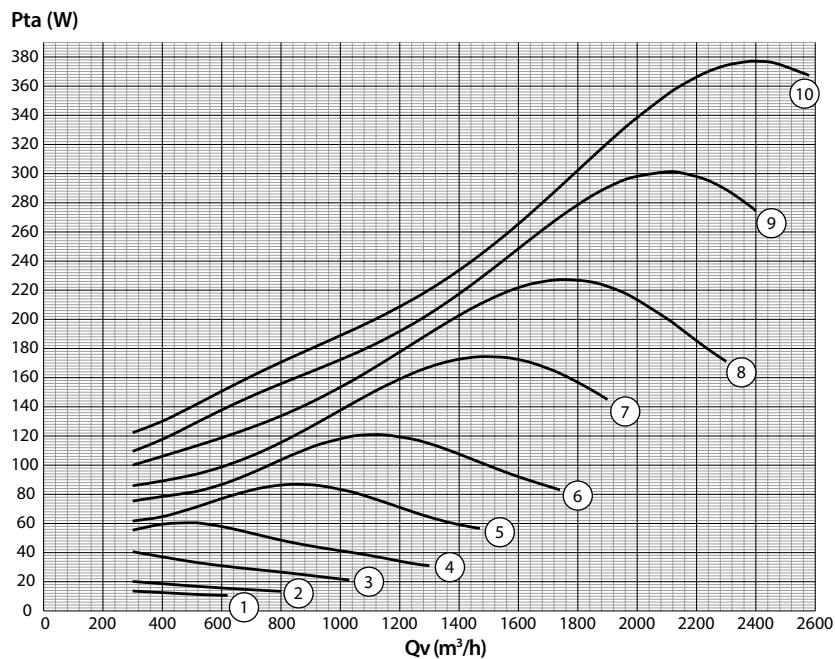

Model 3

Typical fan curves related to the various voltage supplies of the inverter board.

Flow rate/ Available static pressure

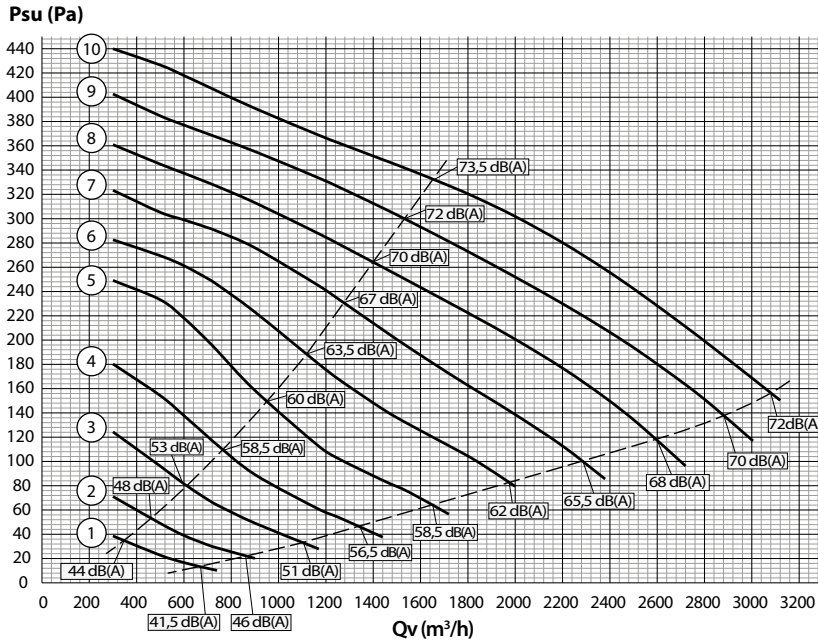

(X) = control voltage
 Psu = available static pressure
 Qv = flow rate
 dB(A) = global sound power

Absorbed electrical power

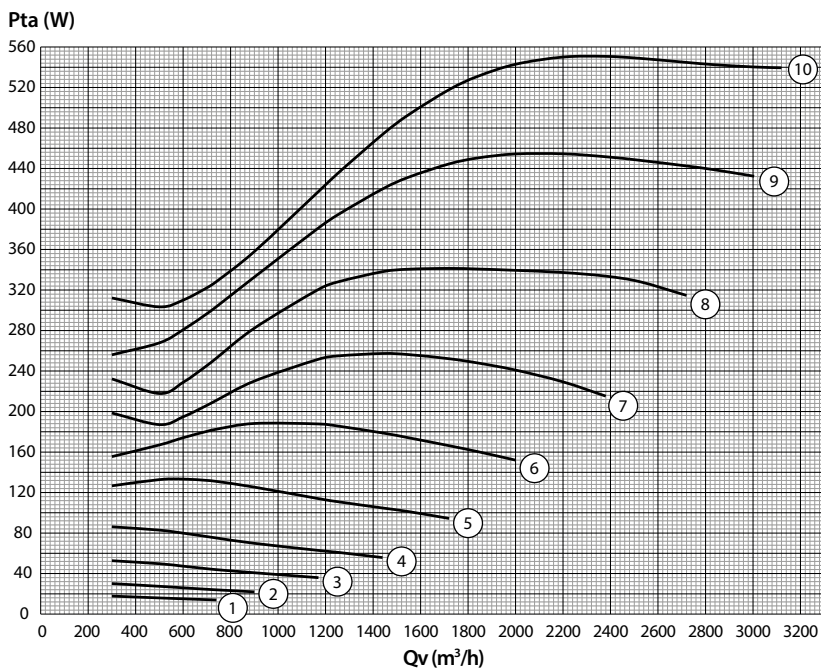

(X) = control voltage
 Pta = absorbed electrical power
 Qv = flow rate

Model 4

Typical fan curves related to the various voltage supplies of the inverter board.

Flow rate/ Available static pressure

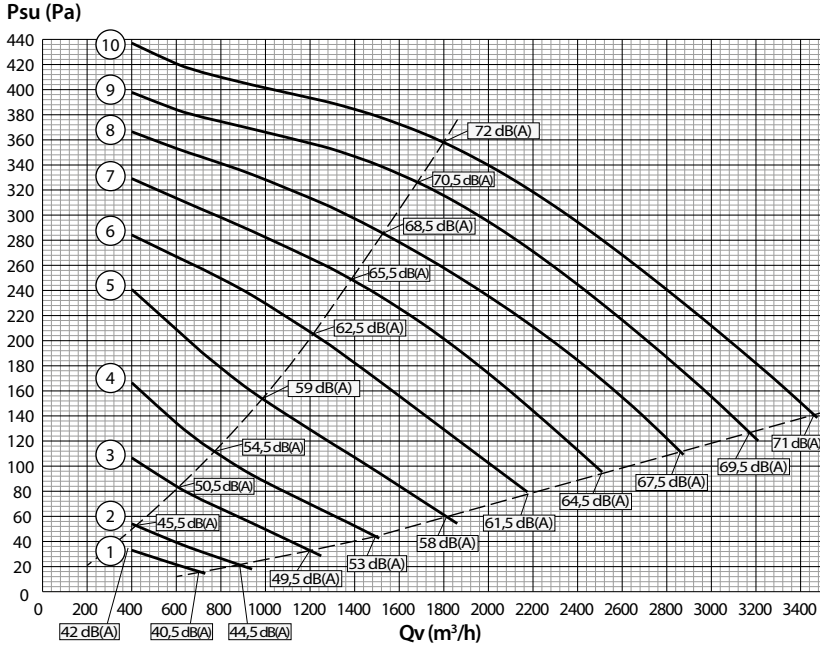

⊗ = control voltage
 Psu = available static pressure
 Qv = flow rate
 dB(A) = global sound power

Absorbed electrical power

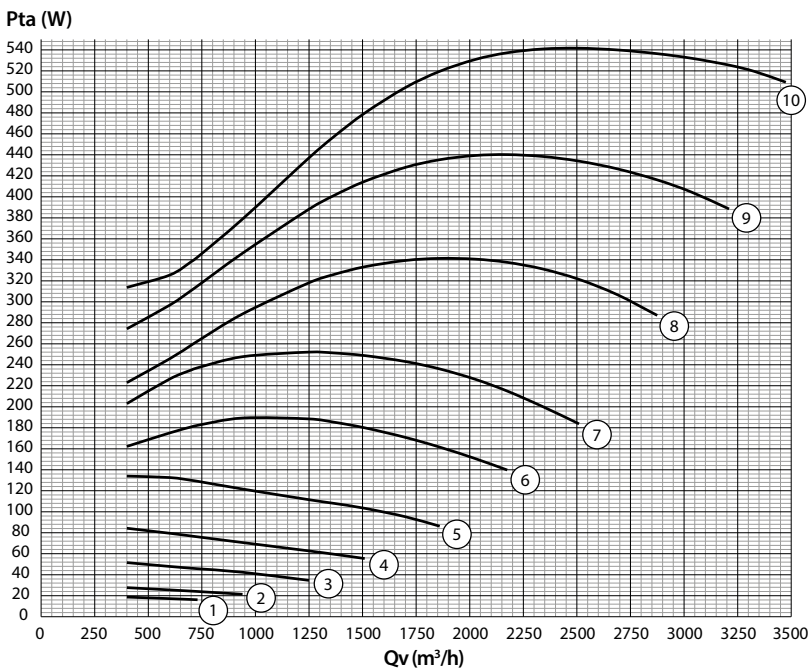

⊗ = control voltage
 Pta = absorbed electrical power
 Qv = flow rate

Model 5

Typical fan curves related to the various voltage supplies of the inverter board.

Flow rate/ Available static pressure

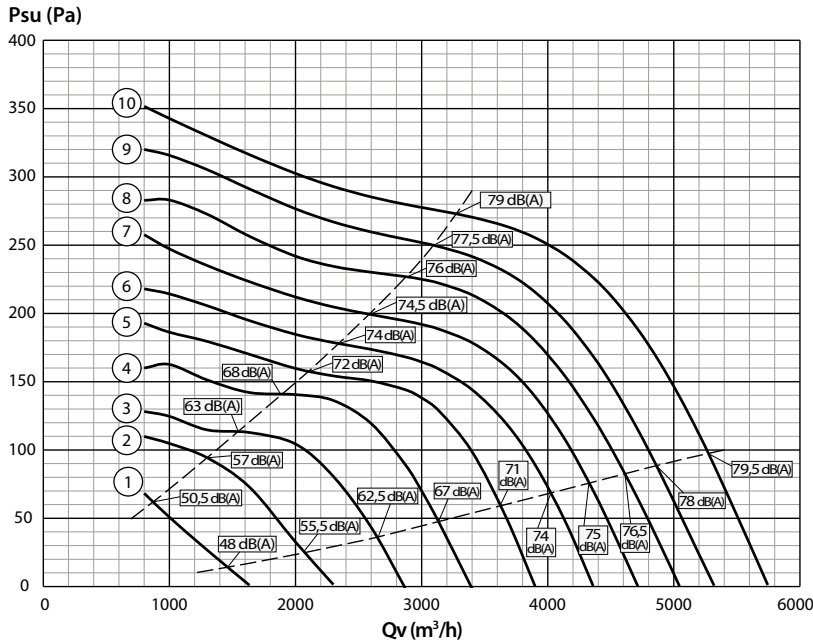

Absorbed electrical power

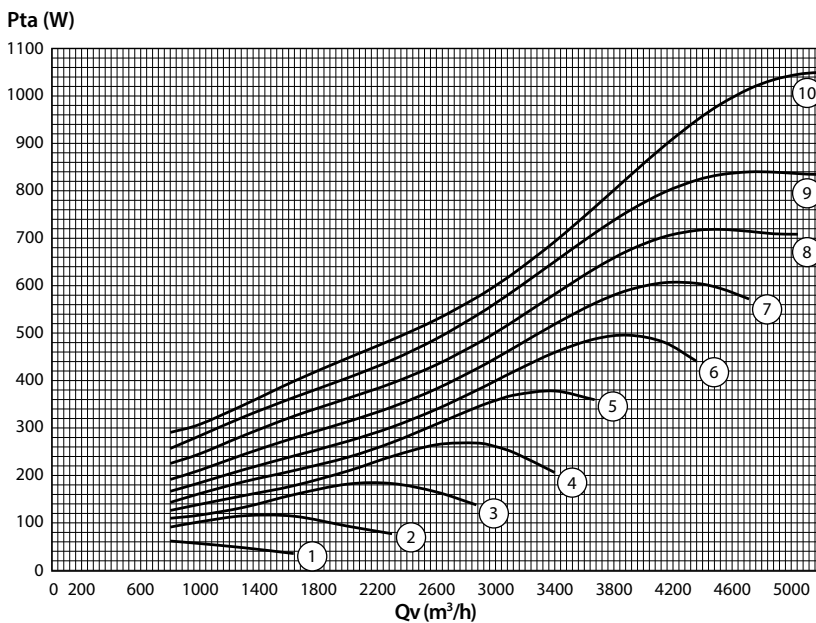

Range and air flow performance

Model		1	2	3	4	5
Dimensions L x H	mm	1165 x 325		1165 x 390	1485 x 390	1485 x 450
Flow rate range	m ³ /h	600 - 1400	1000 - 2200	1200 - 2800	1600 - 3200	2200 - 4600
Available static pressure range	Pa	80 - 210	80 - 220	90 - 360	100 - 370	100 - 300
Irradiated sound pressure range ⁽¹⁾	dB(A)	33 - 48	36 - 53	39 - 56	42 - 59	44 - 63
Cooling emission range ⁽²⁾	kW	2,96 - 8,08	4,76 - 11,87	5,89 - 15,56	7,80 - 19,51	10,67 - 27,94
Heating emission range (3 - 4 row coils) ⁽³⁾	kW	4,32 - 10,06	6,87 - 15,27	8,29 - 18,00	11,73 - 22,84	16,14 - 32,50
Heating emission range (1 - 2 row coils) ⁽⁴⁾	kW	2,57 - 9,54	3,94 - 14,32	4,73 - 17,79	6,46 - 21,97	8,68 - 29,65
Absorbed electrical power range	W	8 - 186	10 - 380	10 - 550	15 - 530	40 - 1045

- (1) The sound power is referred to a room volume of 100 m² Sabine, directional factor Q=2 (hemisphere sound emission) and measurement performed at 3 meters from the source; the data are related to the typical curves of a system with medium external pressure. According to the external pressure and to the selected speed, the values can vary ± 4 dB(A) with regard to the declared values.
- (2) Cooling emission referred to the following standard rating conditions : entering air temperature 26 °C, 50% relative humidity, water 7 / 12 °C, 3 - 6 row coils.
- (3) Heating emission referred to the following standard rating conditions : entering air temperature 20 °C, water 50 / 45 °C, 3 - 4 row coils.
- (4) Heating emission referred to the following standard rating conditions : entering air temperature 20 °C, water 60 / 50 °C, 1 - 2 row coils.

VO-230 **230 V ON-OFF VALVE KIT**
for main and additional coil



VO-24 **24 V VALVE KIT**
for main and additional coil



FMP/FRP **Air supply and return flat flange with**
rectangular opening

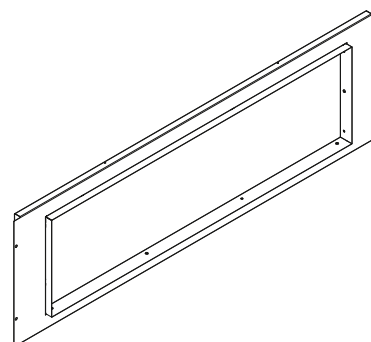

FMC/FRC **Air supply and return flange with circular**
spigots

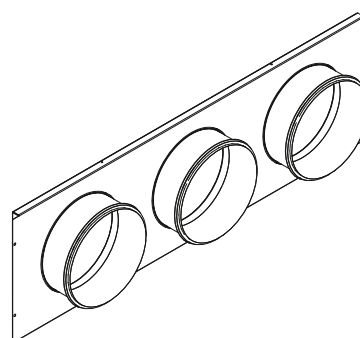

BMA-DP **Air outlet grid**

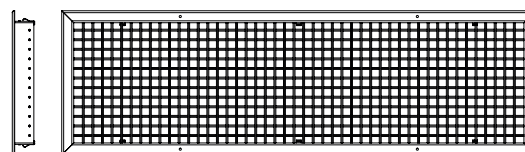

GRA **Air inlet grid**



SRA-DP Interception damper

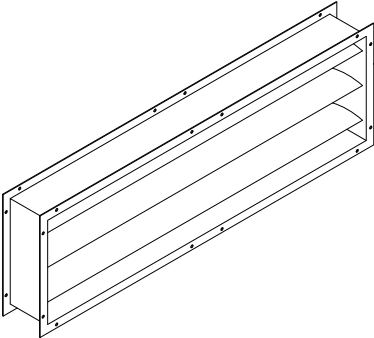

WALL CONTROLS FOR OCEAN-ECM DOUBLE INSULATED PANEL

Each unit must be supplied with an ADC converter or UPO-AU power unit for wall controls

WM-AU	Automatic speed switch with electronic thermostat and summer/winter switch (to use with UPOM-AU or with UPO-AU power units only)
T-MB2	Wall control with LCD color display and WiFi (to be used with UPOM-AU or with UPO-AU power units only)
UPOM1-AU	UPO-AU power unit for WM-AU and T-MB2 remote controls, fitted on the unit
UPO1-AU	UPO-AU power unit for WM-AU and T-MB2 remote controls, not fitted on the unit

T-MB2



WM-AU



Electronic controls for MB board

QCV-MB2-M 1-6	MB2 version control board, fitted on the unit (T-MB2 control included; it can be used with 24V - 3 points valve or 230V ON-OFF valves)
QCV-MB2-S 1-6	MB2 version control board, not fitted on the unit (T-MB2 control included; it can be used with 24V - 3 points valve or 230V ON-OFF valves)
PSM-DI	PSM-DI multifunction control panel (to be used with QCV-MB2 control panel only)
T-DI	T-DI touch screen multifunction control panel (to be used with QCV-MB2 control panel only)
SabWeb	Web gateway for Sabiana Cloud (to be used with QCV-MB2 control panel only)

Software/Hardware control of several Ocean-ECM Double insulated panel

Sabianet	Hardware/software supervision system (to be used with QCV-MB2 control panel only)
Router-S	Router for Sabianet (default) or for BMS systems not provided by Sabiana (to be used with QCV-MB2 control panel only)
SIOS	Relay output board (to be used with QCV-MB2 control panel only)



Follow us on

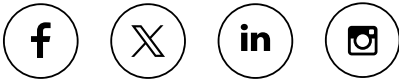

Sabiana app

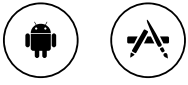

01/2025



SABIANA SpA

Società a socio unico

Via Piave 53 - 20011 Corbetta (MI) Italia

T. +39 02 97203 1 r.a. - F. +39 02 9777282

info@sabiana.it

www.sabiana.it

Management and Direction ARBONIA AG



Sabiana 2 and Sabiana 3 - Operative unit "via Virgilio 2 - Magenta (MI)"
Sabiana 4 - Operative unit "via Zanella 27 - Corbetta (MI)"