



**SABIANA**  
IL CLIMA AMICO

# WebGateway and Cloud Operating Manual



A/03/19  
COD. 4051233E



# Index

<b>Wiring Diagram</b> .....	<b>4</b>
<b>Installation</b> .....	<b>5</b>
<b>Network addresses</b> .....	<b>6</b>
Board address Dip Switch setting.....	6
<b>Operational Instructions For Connection With Rs 485 Serial Line</b> .....	<b>7</b>
Installation notes.....	7
Earthing of network.....	7
Cable specification.....	8
Cloud structure.....	9
<b>TCP-IP Web Gateway Configuration</b> .....	<b>11</b>
Automatic configuration with DHCP.....	11
Manual configuration TCP-IP.....	11
Note for network administrators.....	11
<b>Activation – Login- First installation</b> .....	<b>12</b>
<b>Main interface</b> .....	<b>14</b>
Alarm menu.....	14
Info menu.....	14
<b>Monitoring</b> .....	<b>15</b>
Operating Parameters Modify.....	15
<b>System management</b> .....	<b>17</b>
<b>Master &amp; Slave</b> .....	<b>19</b>
<b>Input - Output I/O Board</b> .....	<b>20</b>
I/O board management.....	21
<b>RVU - Recovery Units</b> .....	<b>23</b>
Operating Parameter Modify.....	23
<b>Heat pump - Energy Genius</b> .....	<b>24</b>
Operating Parameter Modify.....	24
Modify logics.....	24
<b>Program management</b> .....	<b>25</b>
<b>Alarms</b> .....	<b>29</b>
<b>Report</b> .....	<b>30</b>
<b>Administration</b> .....	<b>30</b>

# Wiring Diagram

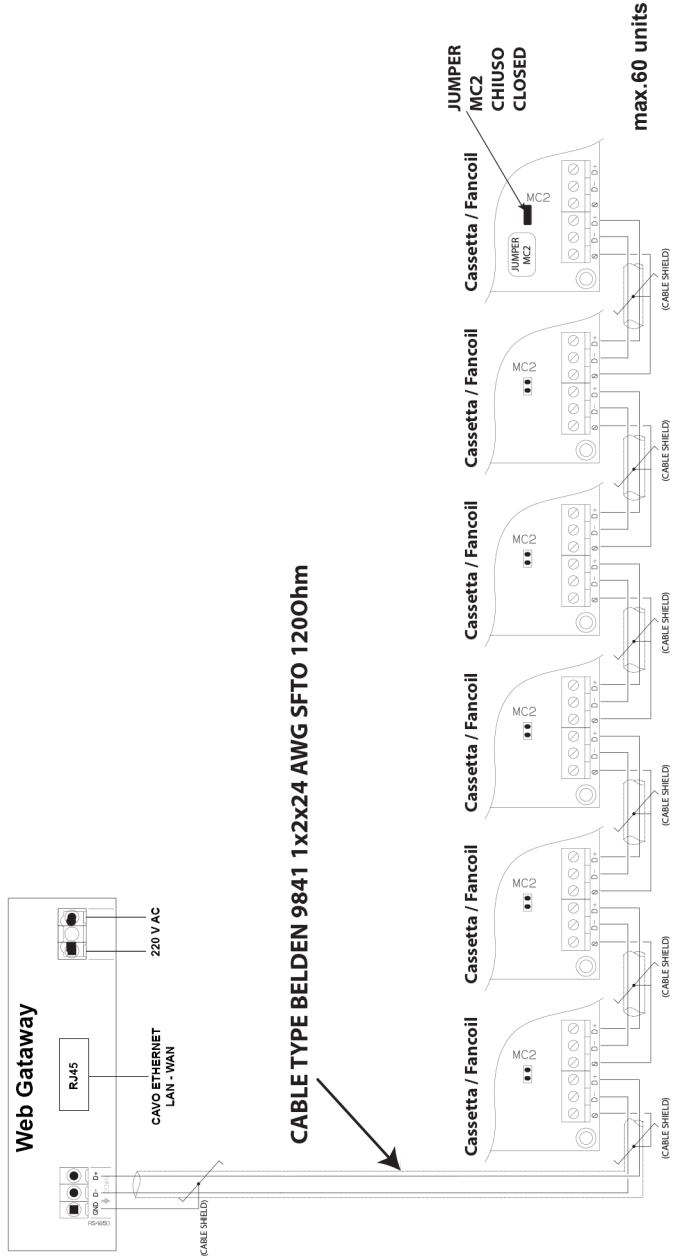

# Installation

1

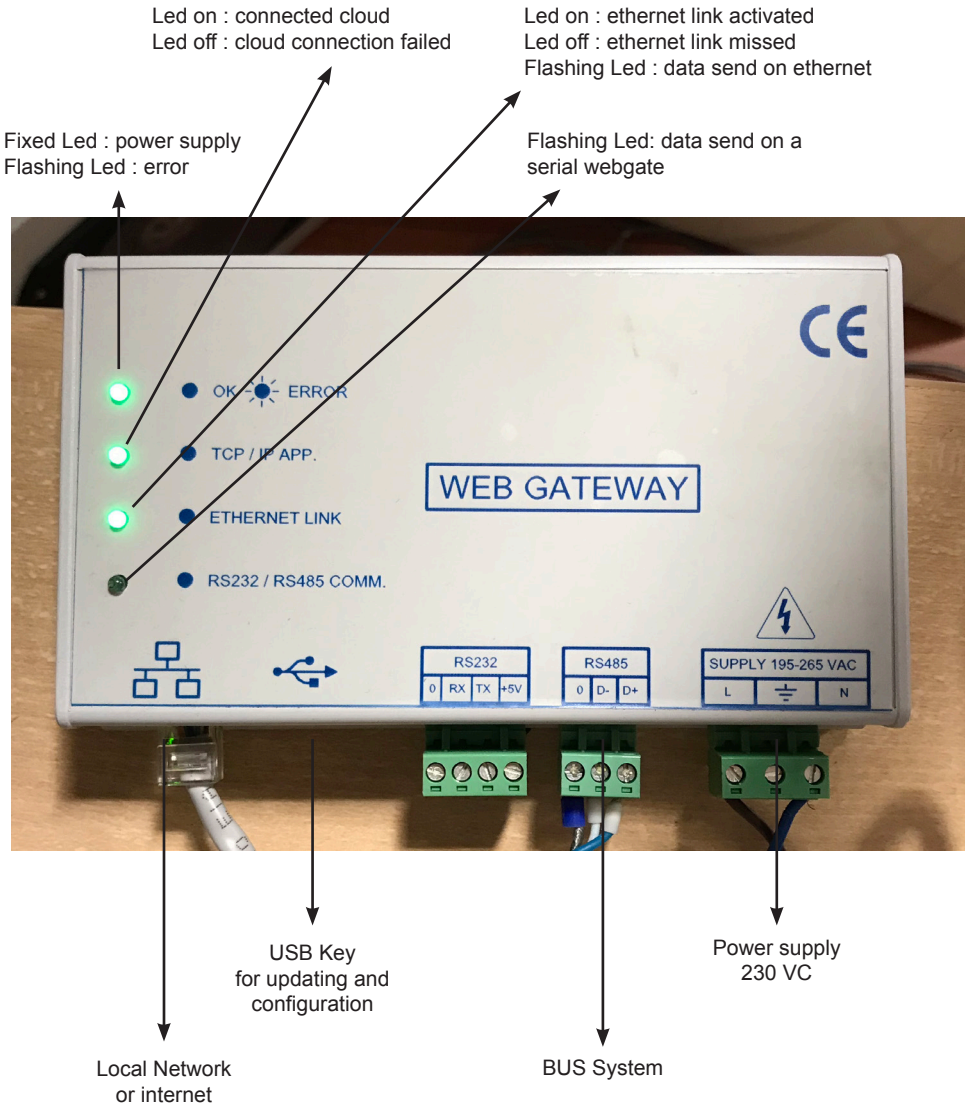

## Network addresses

It is important for every unit to have an univocal address when an appliance network is set up, so that the software recognises it and, therefore, manages it.

We recommend making a note of each machine's position, with its address number, onto a system drawing, to simplify machines' setting and management. We, therefore, recommend creating a table with all data required for tracing each individual installed unit.

## Board address Dip Switch setting

Two micro switch blocks are present on each unit's electronic board: D1 is used to configure the wanted operation; D2 is used to define the address number of each machine. The assignment works according to the binary method; the number is defined by placing the different Dips at On or at Off. Use the following table to set the numbering. Pay particular attention to avoid assigning the same number to more units.

D1 = Configuration Dip Switch

**D2 = Address Dip Switch**

Example of address assigning: wanting to assign 1 to the first unit, 2 to the next and so on for the others:

- No. 1 unit: Dip 1 ON
  - No. 2 unit: Dip 2 ON
  - No. 3 unit: Dip 1 and 2 ON
  - No. 4 unit: Dip 3 ON
  - No. 5 unit: Dip 1 and 3 ON
- all others OFF  
all others OFF  
all others OFF  
all others OFF

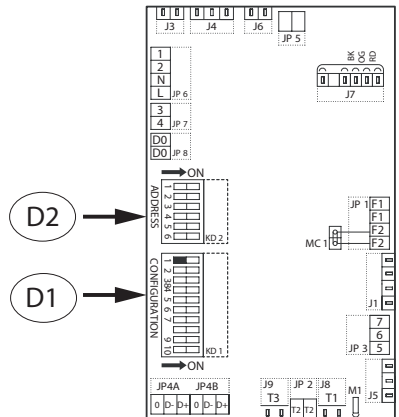

Indirizzo/ Address	Dip Switches ON	Indirizzo/ Address	Dip Switches ON	Indirizzo/ Address	Dip Switches ON	Indirizzo/ Address	Dip Switches ON
1	1	21	1+3+5	41	1+4+6	61	1+3+4+5+6
2	2	22	2+3+5	42	2+4+6		
3	1+2	23	1+2+3+5	43	1+2+4+6		
4	3	24	4+5	44	3+4+6		
5	1+3	25	1+4+5	45	1+3+4+6		
6	2+3	26	2+4+5	46	2+3+4+6		
7	1+2+3	27	1+2+4+5	47	1+2+3+4+6		
8	4	28	3+4+5	48	5+6		
9	1+4	29	1+3+4+5	49	1+5+6		
10	2+4	30	2+3+4+5	50	2+5+6		
11	1+2+4	31	1+2+3+4+5	51	1+2+5+6		
12	3+4	32	6	52	3+5+6		
13	1+3+4	33	1+6	53	1+3+5+6		
14	2+3+4	34	2+6	54	2+3+5+6		
15	1+2+3+4	35	1+2+6	55	1+2+3+5+6		
16	5	36	3+6	56	4+5+6		
17	1+5	37	1+3+6	57	1+4+5+6		
18	2+5	38	2+3+6	58	2+4+5+6		
19	1+2+5	39	1+2+3+6	59	1+2+4+5+6		
20	3+5	40	4+6	60	3+4+5+6		

## Operational Instructions For Connection With Rs 485 Serial Line

Particular attention must be given in electrically connecting a cassette network using serial connection:

1. type of cable to be used;
2. the network's overall length must not exceed 700/800 metres. (provide more terminals if necessary to increase the overall distance);
3. a maximum of 60 cassette can be connected.

### Installation notes

1. Tighten the cables to a force of less than 12 kg. A greater force may fray the cables reducing the transmission properties.
2. Do not twist, knot, crush or fray the cables.
3. Do not lay the signal and power cables together if they must cross, intersection must be at 90°, do not join cable sections. Always use only one cable to connect the individual units together.
4. Do not excessively tighten the cables under the terminal connection clamps.
5. Carefully strip the cable end.
6. Do not crush the cable at cable glands or safety supports.
7. Always respect the colours position in correspondence of the connection start and end points.
8. Visually and physically check the cables are in good condition and correctly positioned, once wiring is completed.
9. Install the cables and units minimising the possibility of accidental contacts with other power cables or potentially dangerous cables, such as the lighting system cables.
10. Do not lay the 12 volt power supply and communication cables near power rods, lights, antennae, transformers or hot water or steam pipes.
11. Never position the communication cables in any conduits, pipes, junction boxes or other container together with the power cables or lighting system cables.
12. Always adequately separate communication cables from all other electrical cables.
13. Keep the communication cables and the units, at least 2 metres away from units with heavy inductive loads (distribution panels, motors, generators for lighting systems).

**Earthing of network:** respect the connection symbols during appliances' serial connection:

- clamp "D-" with clamp "D-"
- clamp "D+" with clamp "D+"
- clamp "0": connect the serial cable's shielding.

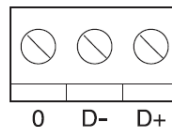

**NEVER INVERT CONNECTIONS.**

## Cable specification

Use **Belden 9841** cable for the RS 485 serial line execution.

RS-485, 1x2x24 AWG SFTP, 120 Ohm, Interface cable, PVC wrap, resistant to cold

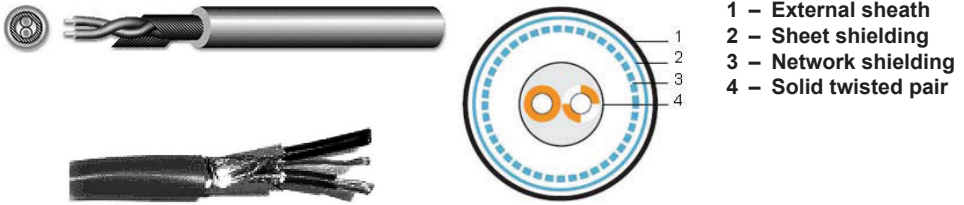

## Description

Instrumental cable for RS-485 applications consists of a twisted pair (24 AWG), wrapped in aluminium sheet shielding and twisting. The cable is wrapped in extremely resistant PVC wrap. The cable complies with UL 1581 VW-1 standard.

## Material

Conductive material: multicore, soft tinned copper conductor

Cores insulation: foamed polyolefin.

Shielding: aluminium sheet (metal side on external part) and copper twisted mesh, density of sheet shielding - 100%, twisting - 90%, 0.127 mm

External sheath: extremely resistant PVC

## Line Limits

The line must not be longer than 800 metres. A maximum of 60 units can be connected under each branch.

## Connection Diagram

Connect all cascade appliances with a chain connection



## Cloud Structure

Sabiana Cloud is a new device to improve the setting of Sabianet configuration. The supervision and logic of the installation are moved to a safe and efficient global cloud.

The heart of the system is the Web Gateway that is in charge for “moving” all the data system on the Cloud. The Web Gateway acts like a bridge between the former structure of the units that are connected with each other through the BUS and the new world of the Cloud. The Web Gateway has the duty to find all the machines available on the BUS, recognize them and and put all their data online in an encrypted way.

The Cloud will decode all data related to the units, log all changes and probable alarms and send all commands, manual changes or actions defined by the programs included.

With the creation of one or more virtual configurations within the Cloud, you can manage several Web Gateways in an extremely easy way and flexibility.

Hier an easy example: a configuration containing a single Web Gateway

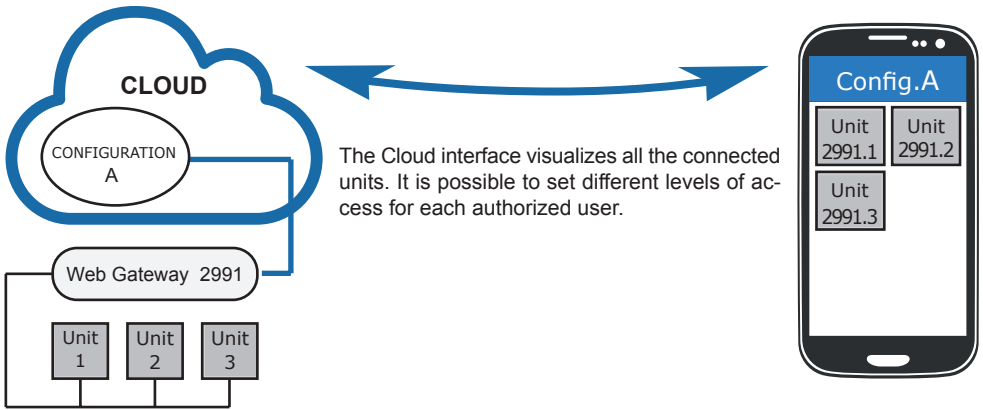

Second level: a user has two Web Gateways and decides to create two different configurations

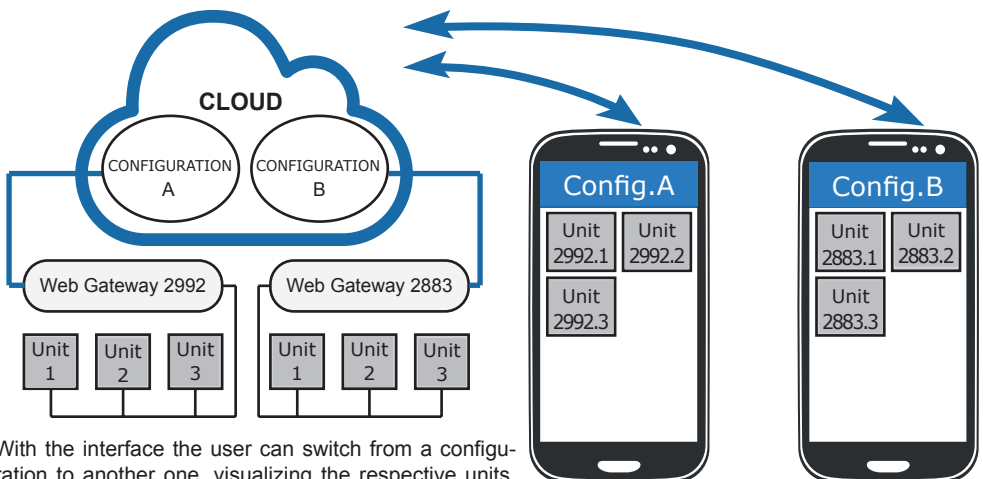

With the interface the user can switch from a configuration to another one, visualizing the respective units. Each setting will be related to the visualized configuration and there is no possibility of communication between the two configurations.

Third example: a user has two Web Gateways and decides to create a single configuration

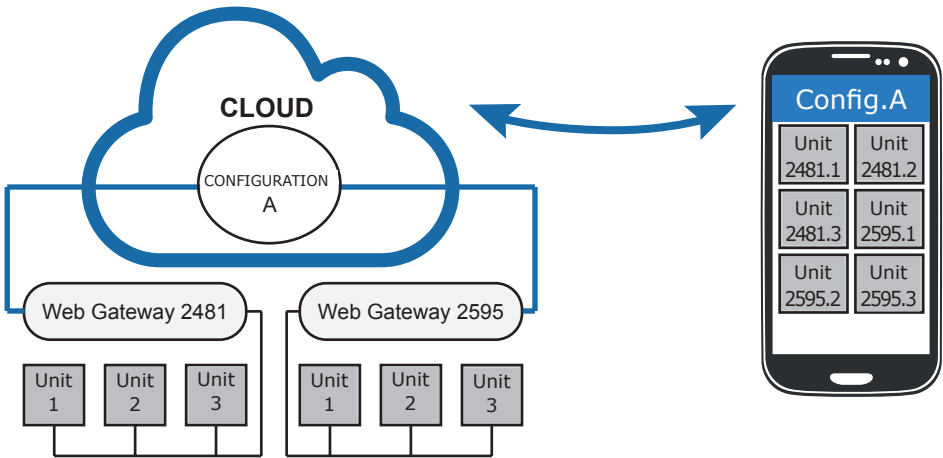

The interface shows all the units of both the Web Gateways, as if they were connected to the network. All the settings will be shared and there will not be any differences between the units, that are connected to different Web Gateways.

The user can freely decide to divide or not the Web Gateways on more configurations, no matter from which geographical position of the devices or from the type of internet connection.

The only limit is related to the time zone for the program execution. Each configuration has got a set time zone. The execution takes place according to that time zone.

## TCP-IP Web Gateway Configuration

The Web Gateway to be activated needs to be connected to the internet.

An Ethernet Web Gateway to be connected to the local network is available. If your configuration has no wired network but a WiFi connection, you have to buy and configurate WiFi - Ethernet access point.

The Web-Gateway does not work until the ethernet link is on.

### Automatic configuration with DHCP

The DHCP is activated as default. So if a DHCP service is available and rightly configured for your network, the Web Gateway will be automatically connected to the Internet.

### TCP-IP manual configuration

If you need otherwise to configurate the TCP-IP use the site <https://config.sabiana.cloud>. Click on the "Create" button and fill all requested fields.

Sabiana Cloud - Web gateway configuration

CREATE VIEW

New configuration

Gateway type  Cloud  MODBus

DHCP  OFF  ON

IP address

192.168.1.20

Subnet

255.255.255.0

Gateway

192.168.1.1

DNS 1

8.8.8.8

DNS 2

8.8.4.4

Generate new configuration set

If you are in doubt about the meaning of the fields or values to insert, ask your network administrator.

Once clicked on the status "Generate new configuration set" a file will be saved under the name "LGKCloud.cfg". Save it on an USB key and insert it into the Web Gateway and restart it. Once the two leds "TCP/IP APP" and "ETHERNET LINK" stop flashing, remove the USB key and the Web Gateway will restart automatically.

### Note for network administrators

The Web Gateway execute only HTTP POST callings towards servers belonging to the field:  
\*.sabiana.cloud

It is not necessary neither to log specific webgates nor specific firewall configurations.

## Activation - First Installation

Once executed all the connections, the Web Gateway will start automatically and scan all the network. Once the 3 leds OK, TCP and Ethernet are fixed, the Web Gateway is ready.

Go to the link <http://www.sabiana.cloud> or otherwise download the “Sabiana Cloud” App from the AppStore or from the PlayStore.

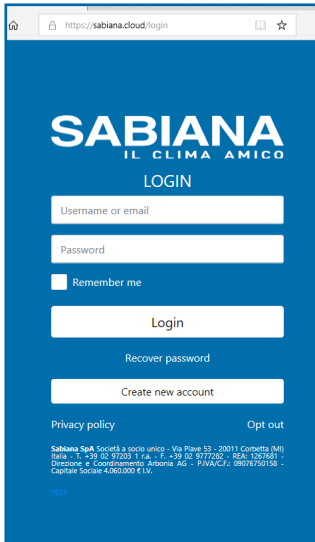

*www.sabiana.cloud web site*

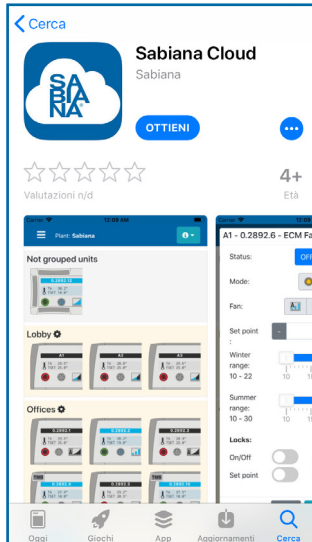

*Sabiana Cloud on AppStore*

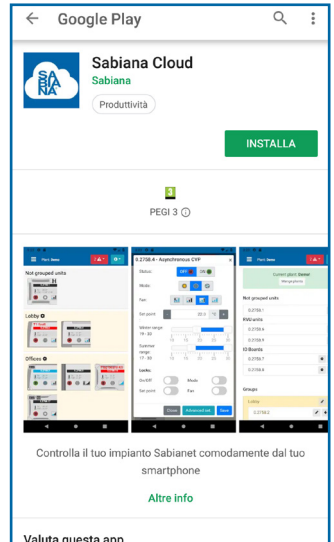

*Sabiana Cloud on PlayStore*

Create a new account with the “Create a new account” button and fill all the requested data.

### CREATE NEW ACCOUNT

Your email	<input type="text" value="test@demo.com"/>
Your name	<input type="text" value="Demo"/>
Your surname	<input type="text" value="Test"/>
Your company (optional)	<input type="text"/>
Your country	<input type="text" value="Italy"/>

Terms and conditions versione 1 from Mon, 1/1/2018

Terms and conditions to be inserted.  
 Terms and conditions to be inserted.  
 Terms and conditions to be inserted.  
 Terms and conditions to be inserted.

I Agree

Privacy policy

Privacy Policy of sabiana.cloud  
Sabiana.cloud collects some Personal Data from its Users

Owner and Data Controller  
Sabiana S.p.A. Società a socio unico - Via Piave 53 - 20011 Corchetta (MI) Italy - T. +39 02 977703 S.p.A. - E. 39.02.977770 - SEI - 1367461 - P.IVA/02040001508

I Agree

After having inserted all the requested data, press the “Create a new account” button

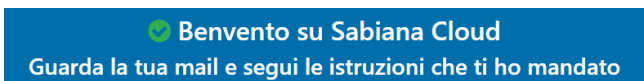

You will receive an e-mail to the e-mail address that you gave during the login section. Click on the “Complete” button and you will be requested to insert a password for your account.

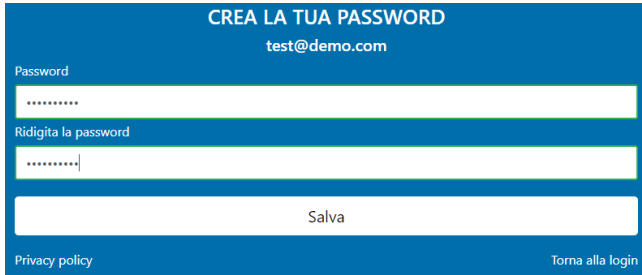

The password must have a capital letter, a tiny one, a number and must have not less than 8 characters. Once inserted press the “Save” button to end the registration process. You will go back to the login home. Use your user name (your email) and password just inserted to access. At the first access a page like this one will appear

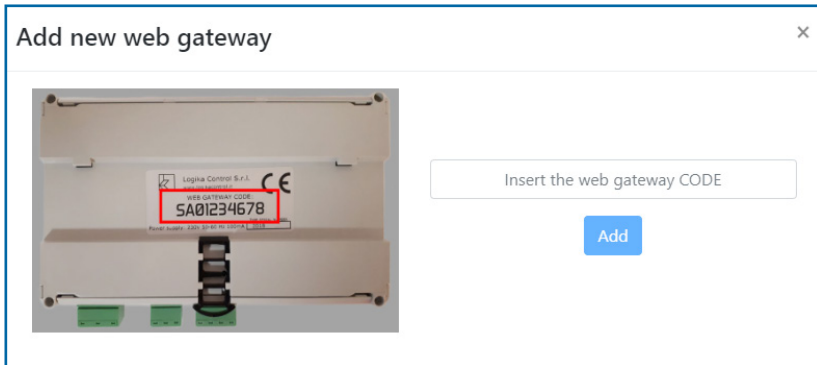

You must insert the code with 10 digits available on the Web Gateway. Once inserted this code, press the “Add” button.

If the inserted code of the Web Gateway is correct and you are the first to have inserted it, you will be requested of creating a configuration. Such configuration within the Sabiana Cloud is an abstract object that contains one or more Web Gateways. They will create a network of machines to manage together. It is possible to create more configurations, each one with a single Web Gateway or with several ones.

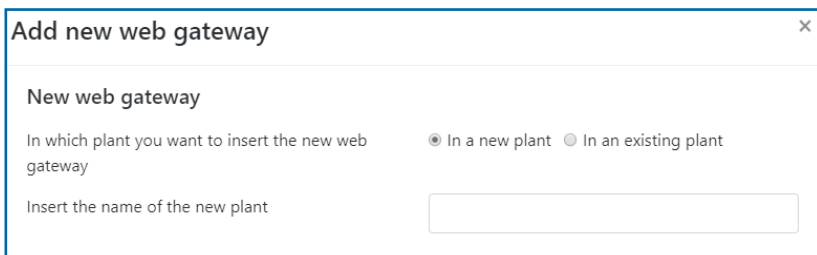

To create a configuration is sufficient to insert the name and press the “Insert” button.

If the Web Gateway code has been already used, you have to ask the owner of the configuration for permission. You will receive by e-Mail the possible authorization or refuse.

## Main Interface

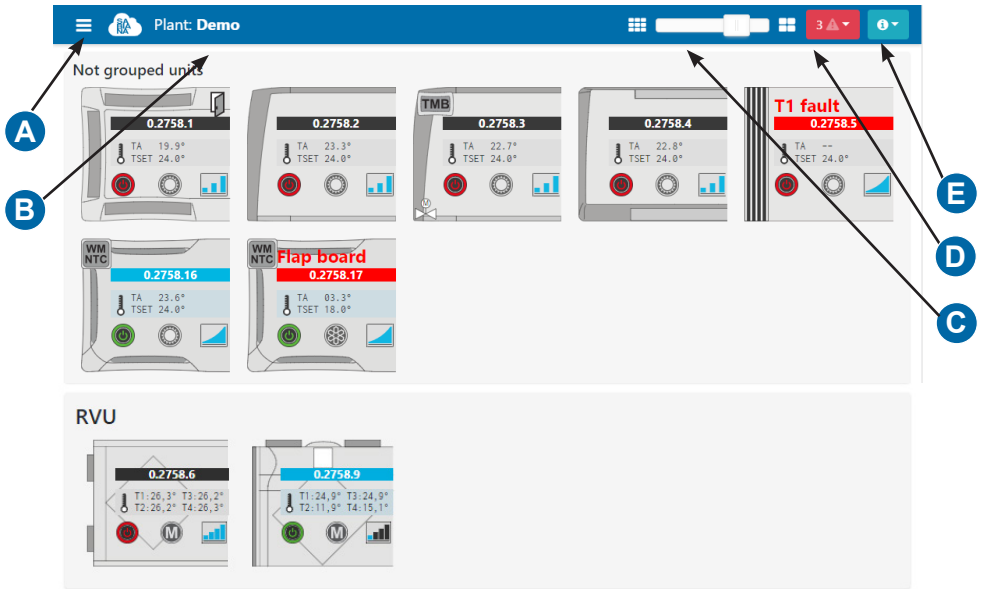

- A. Menu bar: it gives access to all software modules
- B. Current Installation
- C. Bar to resize the icons
- D. Alarm menu, if activated shows the number of alarms on
- E. Info menu

### Alarm Menu

Click on the flashing exclamation point to open the Alarm menu : here is available the list of the units with alarms and if these are on.

If there are no alarms activated, there is no icon.

To close the menu, click on the icon again or on whatever point on the screen.

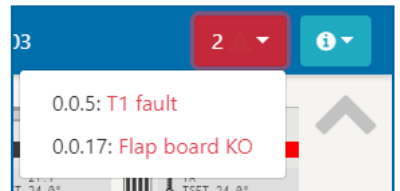

### Info Menu

Click on the icon "i" to open the Info menu and know more about the software version, the user name, the current language and the optional ones.

Select the desired language and the system will switch the interface automatically.

The "Logout" function closes the current section.

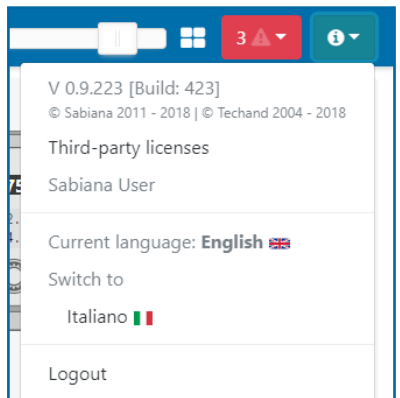

## Monitoring

Select "Monitor" from menu bar.

The screen displays the main parameters of each unit in network in real time.

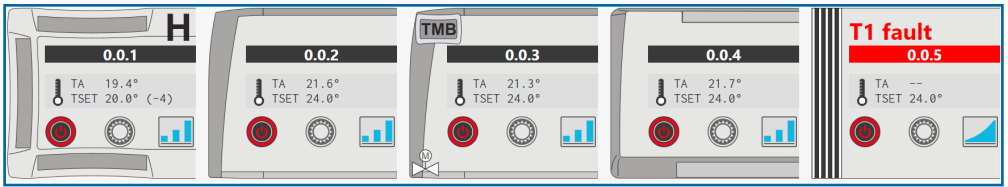

Each unit is shown by means of an icon.

Each icon shows symbols and values providing the following info:

- Unit name (if set), or network address. When it is on the background is blue. If there is the alarm it is red. When it is off is black.
- Ambient temperature (AT) and set temperature (SETP)
- Unit status: ON or OFF
- Unit mode : winter summer automatic or ventilation
- Fan Speed: Low Medium Maxim or Automatic
- Open-window icon or Hotel mode enabled
- Icon wireless and IR remote control, or TMB external thermostat or external thermostat with IR remote control and BlueTooth WM-NTC
- Description of alarm unit
- A lock near one of the symbols means the user cannot modify the relevant parameter through the local control on the unit.

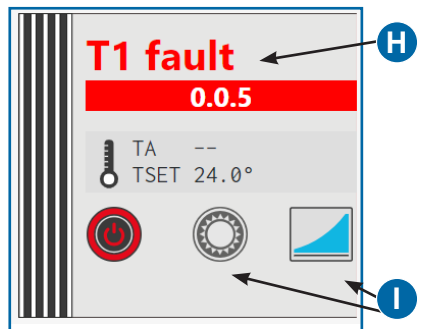
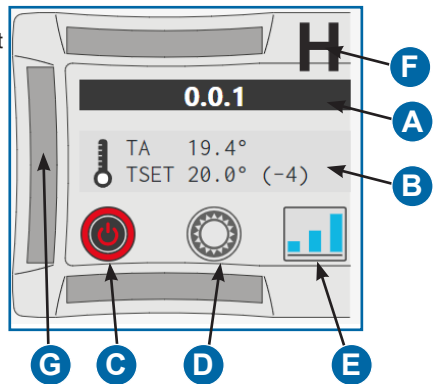

The F2 input sets the unit in **Window** or **Hotel** mode. In Window mode the fan is turned off while in Hotel mode a decrease/increase of the set point by 3/6 degrees occurs. The F2 input settings are to be found in Advanced Settings.

## To modify operation parameters

The parameters of the single unit can be easily set by clicking on the relevant icon, a balloon like the following will be shown:

On the first row you'll see the network address, unit type and name (if set).

In the left column you can change the main parameters:

- ON/OFF: you can switch ON or switch OFF the unit

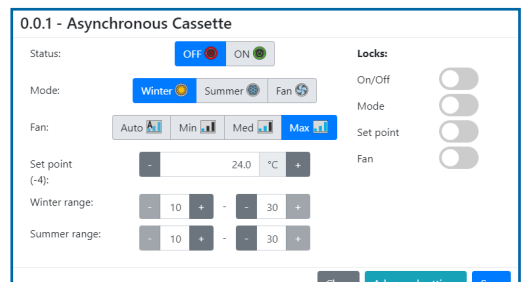

- Fan speed: you can adjust the fan speed
- Set point: temperature to be maintained
- Winter range / Summer range: you can define the set point limits in all seasons

In the right column you can set up the locks of the remote control on the unit in order to prevent the user from changing all or any operational parameters.

Once you've made the changes you want, press the "Save" button to send data to the unit.

The "advanced setting" button opens up a window with all operational data in real time and the unit installation parameters divided into 3 sections.

In the "Unit Status" section there is the list of all operating parameters in real time. Firmware version of the unit and the alarm list included (if there are).

### 0.0.1 - Asynchronous Cassette

Unit status	Configuration	Parameters
Last data update: Fri, 11/16/2018, 10:35 AM [2 seconds ago]		
Group: --	FW: 0.56 [4]	Program:
Local comand: Not installed	MS Network: 5	Unit tree: address: 1
Status: OFF	Mode: Winter	Fan: 3/3
Set point: 20.0° (-4)	Request: --	Inverter voltage: --
T1: 19.4°	T2: --	T3: --
Pump: yes	Remote ON/OFF: OFF	Window: open
LNC 1* condensation level: ON	LNA 2* condensation level: ON	

[Close](#)

In the "Configuration" section there is the list of all dip switches fitted on the unit with the current position, the active meaning and the alternative one.

Dip	OFF option	ON option
1: OFF	<b>2 pipe units</b>	4 pipe units
2: ON	Thermal power station with valves	<b>Thermal power station with Fan</b>
3: OFF	<b>T3 disabled</b>	T3 enabled
4: OFF	<b>T3 only Winter when enabled</b>	T3 Winter and Summer when enabled
5: ON	Continuous ventilation	<b>Simultaneous ventilation of valves</b>
6: OFF	<b>Unit without electrical heater</b>	Resistance-coils Management
7: OFF	<b>T2 as CH Change-Over (resistance phase II)</b>	Resistance-coils with T2
8: OFF	<b>RL7 (D0-D0) according to the state of the controller</b>	RL7 (D0-D0) according to the pump
9: OFF	<b>CA = Remote ON/OFF</b>	CA = Remote Summer/Winter
10: OFF	<b>Master</b>	Slave

In the "Parameter" section there is the list of all specific parameters for each unit, whose values can be changed. The parameter layout lets a better reading. Once you've made the changes you want, press the "Save" button to send data to the unit.

Stato unità	Configurazione	Parametri
T3 ventilatore ON riscaldamento	34.0 °C +	T3 ventilatore ON raffreddamento: 22.0 °C +
Isteresi T3 per ventilatore	5.0 °C +	Tempo massimo OFF ventilatore per antistatificazione: 10 min. +
Tempo ON antistatificazione	60 sec. +	Tempo post ventilazione: 180 sec. +
ECM tensione velocità minima	1.0 V +	ECM tensione velocità media: 5.0 V +
ECM tensione velocità massima	10.0 V +	Offset sonda T-MB: 0.0 °C +

[1](#) [2](#) [3](#) [4](#)

[Chiudi](#) [Imposta orologio TMB](#) [Salva](#)

If an external thermostat TMB is connected to the unit, the function "Configuration of TMB clock" is available. It sends current time and data to the device.

## System management

From the menu bar select “Manage”.

On the main window appears a tree with all units.

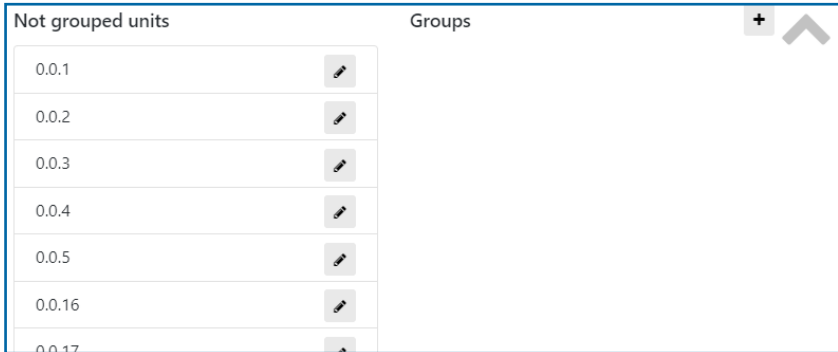

For each unit a “pencil” button is available. It lets change the unit name and add it to a group:

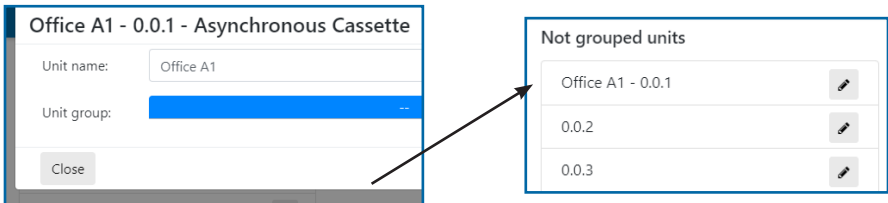

With the “+” button in the upper right more groups can be added to the system. The use of groups is strongly recommended as it helps to easily manage all installed units.

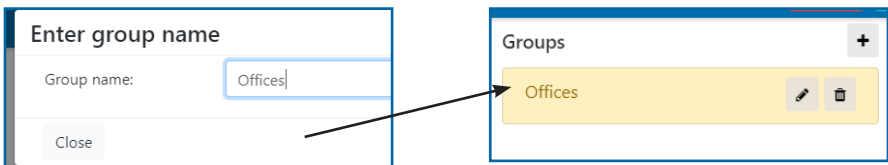

Once a group is added, its name can be changed through the “pencil” button as done for the units and it can be deleted through the “bin” button provided that it contains no units.

Units can be assigned to a group by easily dragging them inside it; an entire router can also be dragged in order to assign all its units.

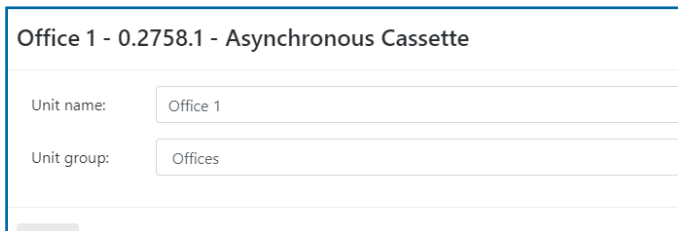

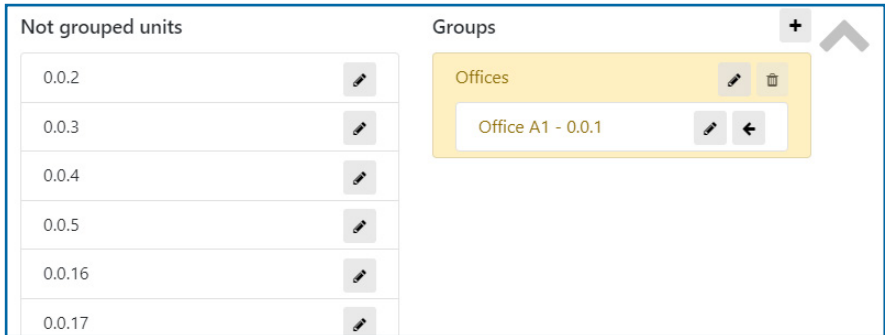

Once a unit is assigned to a group its name can still be changed through the “pencil” button or removed with the “<-”.

After the rearrangement of units within the groups, the main window will reflect the status:

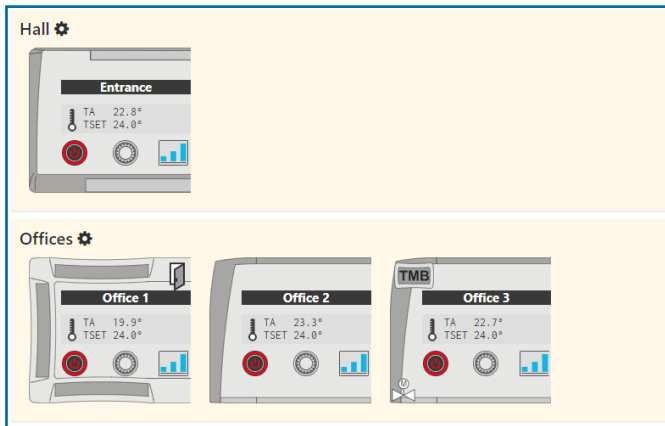

The “Gear” icon located under the group name can be used to set parameters for all the group units. (it is also possible to click on the group area)

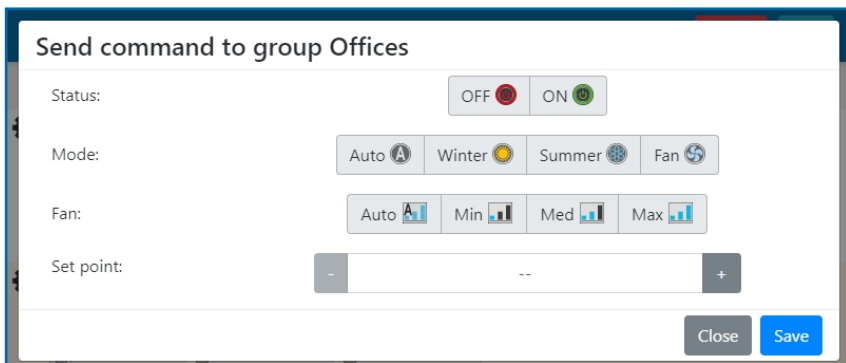

## Master & Slave

The Master & Slave modus lets the creation of special subnetworks where a machine (master) controls the other ones (slave). The slave units can not receive any commands, but they are totally dependent from the master units.

Normally all the units are set as master ones. Use the dip switches to switch their configuration into slave ones. See the manual instruction of each unit to find the correct dip switch.

For a better functioning a master & slave network must correspond to a group, having a single master and one or more slave ones.

At the first activation, with slave units, the interface will show a message like this:

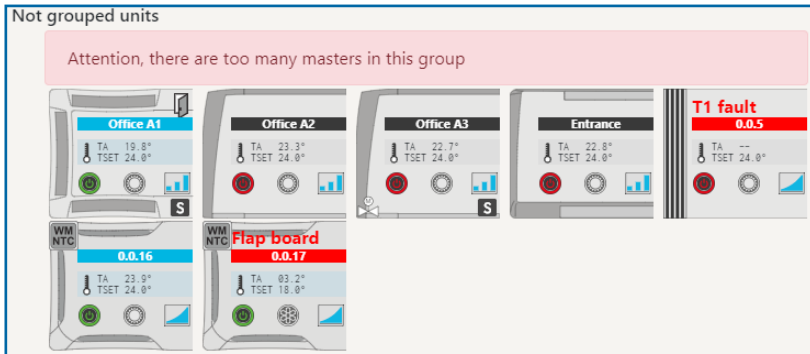

Move to the “Management” section to create a group for your M&S network. Once created the group, add all the necessary units. The interface shows you guide messages according to the group configuration.

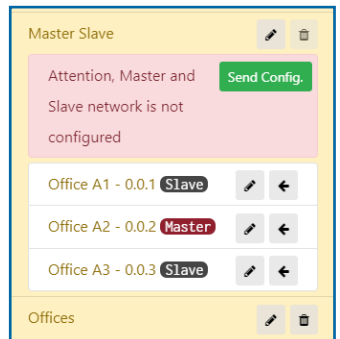
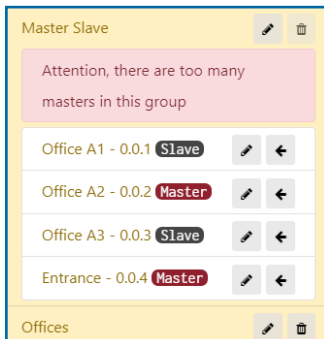
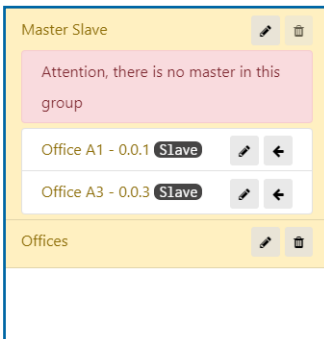

The “Invia conf.” button shows that the setting of the group is correct. Press the button to send the configuration to all boxes. The Master and Slave network is activated.

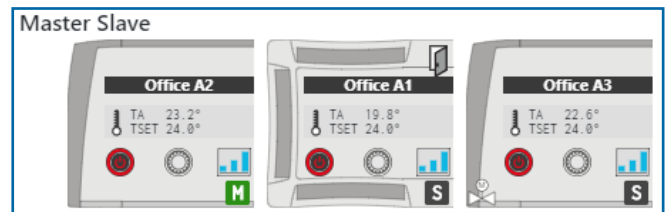
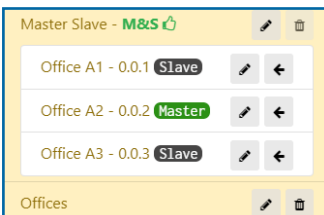

## Input - Output I/O Board

The I/O board is an electronic power board equipped with 8 voltage-free contact inputs for displaying the different devices status and 8 relay outputs with SPST (2A AC3) type NO contact, for controlling remote electric utilities switch-on or off, for example:

- Pumps and Solenoid Valves - Chiller
- Air shutters
- Lights, Outdoor lights - Extractors
- Fans

**The Output board is to combine with the supervisory programs: Sabianet, TD-I o Web Gateway**

The contacts of each individual relay (OUTPUT) identified by output number from 1 to 8 opening/ closing can be managed by means of the Sabianet program or the PSM-DI control, checking the status at any moment. Also, the output relay status can be combined to a weekly program.

Similarly, the status of the inputs contacts can be displayed.

**IMPORTANT!: Firstly define the physical address using the 6 Dip connector.**

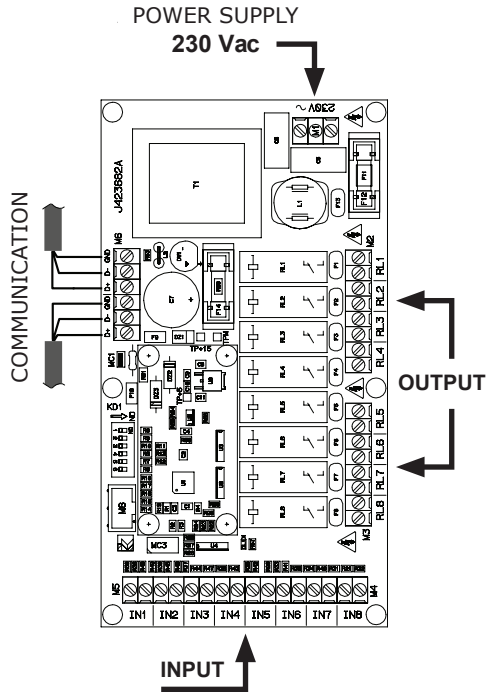

### INPUT

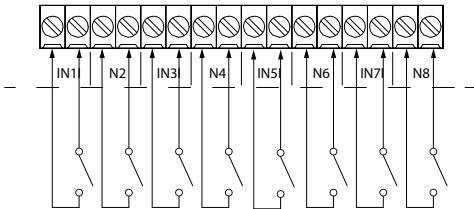

### OUTPUT

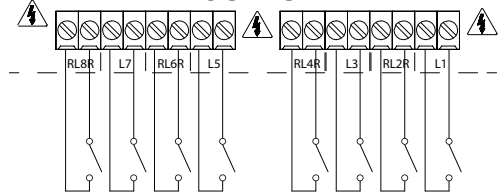

### CLOSED

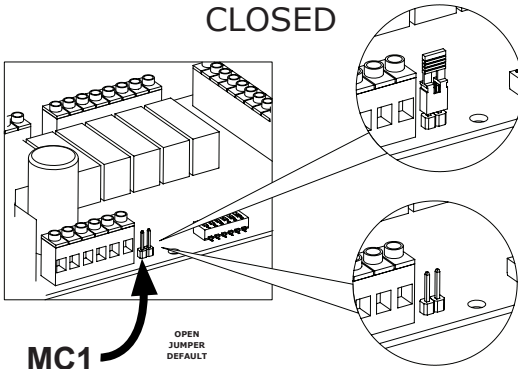

### Serial connection - network end JUMPER.

The network must be closed on the last board in case of RS485 connection (Master/Slave or Sabianet). Closure is through **JUMPER MC1** if the last card is the I/O card.

### OPEN

## I/O board management

In the “Monitor” window the I/O boards appear always at the bottom inside a dedicated “group” and the icon shows the I/O status.

As per the units, by clicking on the icon a balloon will appear to enable the manual setting of outputs.

The “ON” and “OFF” buttons above can be used to quickly set all outputs at the same time.

The “Save” button sends the changes to the board.

In the “Management” section, as per the units, a “pencil” button enables the change of the board name, the I/O names and which inputs are to be considered alarms.

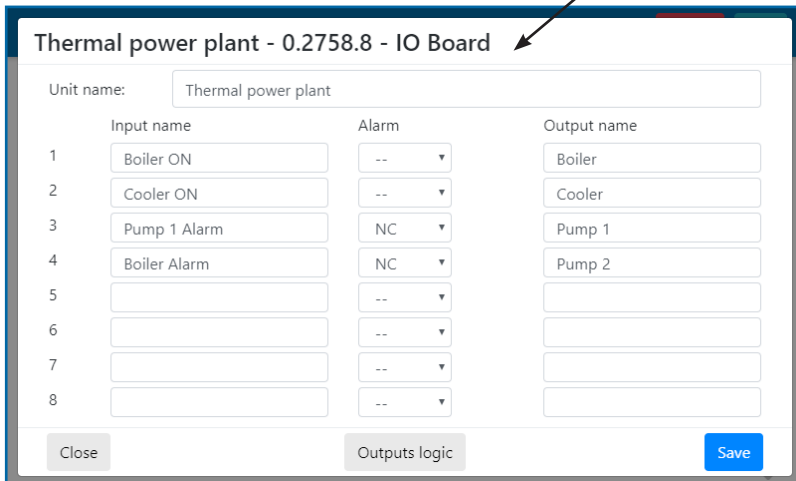
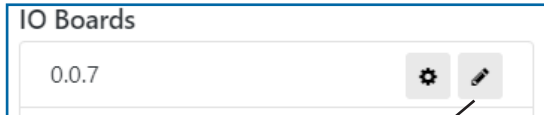
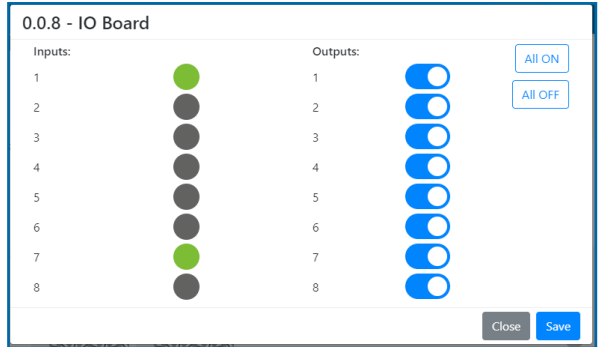
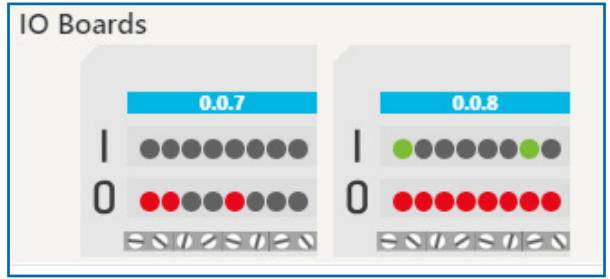

For each input flagged as alarm, you must select if the alarm is on when the contact is closed [NC] or open [NO]

The “Output logic” button shows a window through which you can define the logics for the output contacts opening and closing basing on the system status.

Output name	Mode	Logic
1  Boiler		+
2  Cooler		+
3  Pump 1		+
4  Pump 2		+

**Legend**  
Alarm  
Warm or Cool request  
Warm request  
Cool request  
Unit ON  
Digital input ON  
Digital input OFF

In the left column you can see all available outputs, and the already assigned logics. Click on the icon “+” of every single output to open a screen for the modify.

Mode
Logic

Simple

Advanced

Hall

✖

---

Logiche disponibili:

**Alarm**

All groups
Hall
Offices

**Warm or Cool request**

All groups
Hall
Offices

**Warm request**

All groups
Hall
Offices

**Cool request**

All groups
Hall
Offices

**Unit ON**

All groups
Hall
Offices

**Digital input ON**

Thermal power plant - Boiler ON (1)

Thermal power plant - Cooler ON (2)

⚠ Thermal power plant - Pump 1 Alarm (3)

⚠ Thermal power plant - Boiler Alarm (4)

Thermal power plant - 5

Thermal power plant - 6

**Digital input OFF**

Thermal power plant - Boiler ON (1)

Thermal power plant - Cooler ON (2)

⚠ Thermal power plant - Pump 1 Alarm (3)

⚠ Thermal power plant - Boiler Alarm (4)

Thermal power plant - 5

Thermal power plant - 6

Here below all the events that can generate the closing of the output contact. Click on one event to associate it immediately to the output. For instance, should we want to activate an output in case the “Offices” box requires warm, just click on “Offices” under “Warm Request”.

Mode
Logic

Simple

Advanced

Offices

✖

AND

OR

Thermal power plant - Boiler ON (1)

✖

---

Logiche disponibili:

Warm request
Cool request

It is possible to select “Advanced” options to drag more events towards an output and specify if the activation will start once all conditions of the events will take place (AND) or when only one is active (OR). **To use this advanced function you must be aware of the Boolean logics. Not to use it if you are not more than sure of your knowledge!**

## RVU - Recovery Units

In the main screen "Monitor" the available RVU units are shown always below in a dedicated "group". The icon shows the status of the machine.

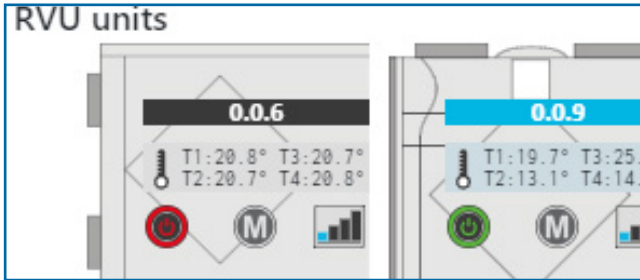

The icon of the units respects the principles and rules of the other units. Here are the On and Off status, the current mode, the fan speed and the temperatures of 4 probes.

### Modify of the operating parameters

Each unit parameters can be easily modified by a click on the respective icon. A window like this one appears.

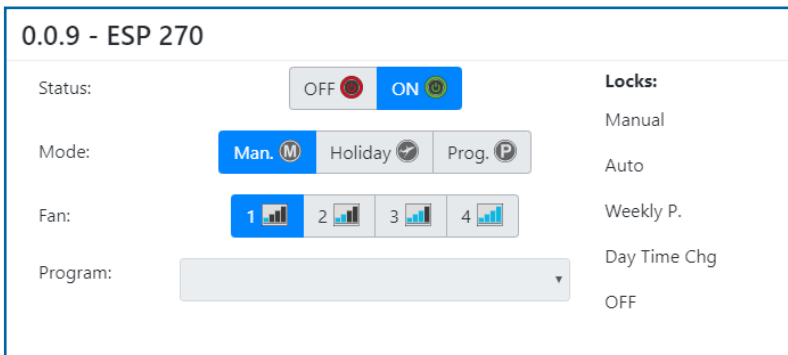

On the first row you'll see the network address, unit type and name (if set).

In the left column you can change the main parameters:

- ON/OFF: you can switch ON or switch OFF the unit
- Mode: lets vary the operating modes
- Fan Speed: sets the fans speed
- Program: once is set, you can select the desired program

In the right column you can set up the locks of the remote controls fitted on the unit, in order to prevent the user from changing all or any operative parameters.

Once you've made the changes you want, press the "Save" button to send data to the unit.

The "advanced setting" button opens up a window with all operational data in real time and the unit installation parameters like the ventilation units. It is possible to set the clock and date of the T-EP local control within the parameter window.

In the "Management" screen for the RVU units it is possible to specify the unit name only.

## Heat Pump - Energy Genius

The Energy Genius units can be connected to the Web Gateway. It is possible to insert one single unit per each Web Gateway. The network address is **preset and not modifiable 60**. [For Energy Genius operative function instructions see page 31]

In the main screen "Monitor" the Energy Genius unit will be shown in a dedicated "group" below. The icon shows the status of the machine.

The icon respects the rules and the principles of the other units. The status of On and Off, the current mode, the occupation, the set and current water temperature.

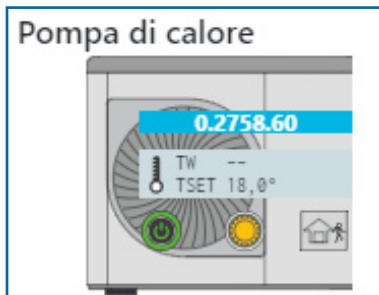

## Operating parameter modify

The unit parameters can be easily modified with a click on the respective icon. A screen like this one appears:

On the first row you'll see the network address, unit type and name (if set).

In the left column you can change the main parameters:

- ON/OFF: you can switch ON or switch OFF the unit
- Mode: lets vary the operating modes
- Occupation mode: sets the setpoint change
- Setpoint: sets the temperatures with 3 operative modes

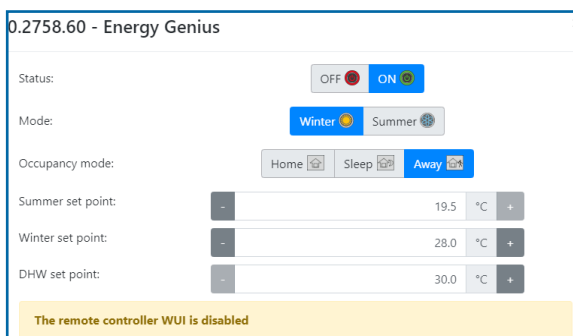

Once you've made the changes you want, press the "Save" button to send data to the unit.

The WUI remote control of the Energy Genius will be deactivated at the first command sent

The "advanced setting" button opens up a window with all operational data in real time and the unit installation parameters like the ventilation units.

## Logic modify

In the "Management" section for Energy Genius units a gear-shaped icon opens a window to choose which boxes follow the heat pump time automatically.

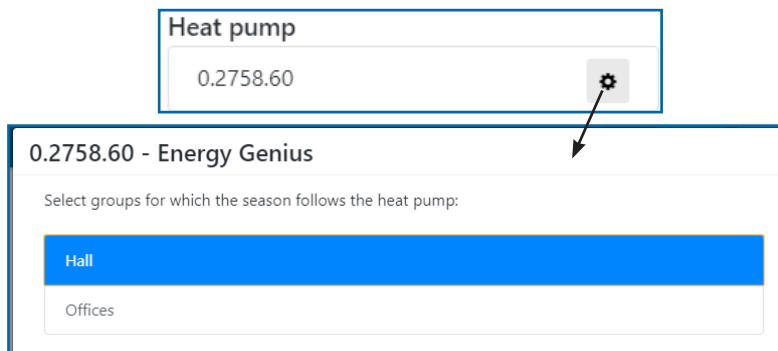

In the specific case when the heat pump switches to the summer time, all the "Common Areas" boxes switch automatically to the summer time.

## Program Management

It is possible to define more programs to associate to the single units or to the groups.

There are two types of programs: the “Weekly Program” and the “Special Program”.

The weekly program lets define a range of parameter variations of the units within 7 day. Otherwise the special program defines one single daily program that is repeated throughout the time of the program validation.

Select “Programs” from the side menu.

The main window will show a list of the units divided in groups and in the right column all the events already included.

The screenshot shows a software interface with two main sections. On the left, titled "Groups and units", there is a list of categories and their associated units, each with a lock icon. The categories and units are: "Not grouped units" (0.2758.5, 0.2758.16, 0.2758.17), "Hall" (Entrance -...), "Offices" (Office 1 - ..., Office 2 - ..., Office 3 - ...), "RVU units" (0.2758.6, 0.2758.9), "IO Boards" (Thermal p..., 0.2758.8), and "Heat pump" (0.2758.60). On the right, titled "Programs available", there is a list of program types: "Units programs", "IO programs", "RVU programs", and "HP programs". A "+" button is located in the top right corner of the "Programs available" section.

The “+” button in the upper right corner enables the addition of a new program.

The screenshot shows a "Create a new program" dialog box. It has two main sections: "Program type" and "Unit type". Under "Program type", there are two options: "Weekly" (represented by a clock icon) and "Special" (represented by a bell icon). Under "Unit type", there are four options: "Units" (represented by a monitor icon), "IO Boards" (represented by a board icon), "RVU units" (represented by a diamond icon), and "Heat pump" (represented by a fan icon). Below these options, there is a "Program name:" label and a text input field containing "Program 1". At the bottom right, there are two buttons: "Close" and "Create".

If you select “I/O board” or “RVU”, you must specify for which board the program is being created.

After having created the program, it is possible to edit it with the “pencil” button. A window like this one appears:

The screenshot shows a "Programs / Edit" window. At the top, it displays the program details: "Program name: Program 1", "Program type: Weekly", and "Unit type: Units". Below this, there is a "Edit program" button and a "Copy day" button. The main part of the window is a grid representing a weekly schedule. The columns are labeled with the days of the week: Monday, Tuesday, Wednesday, Thursday, Friday, Saturday, and Sunday. The rows are labeled with times: 0:00, 1:00, 2:00, and 3:00. The grid cells are empty, indicating that no program events are currently scheduled.

The daily table is shown in short. In this case each line corresponds to an hour. Click on a table cell to expand a line and the intervals of 15 minutes each one appear.

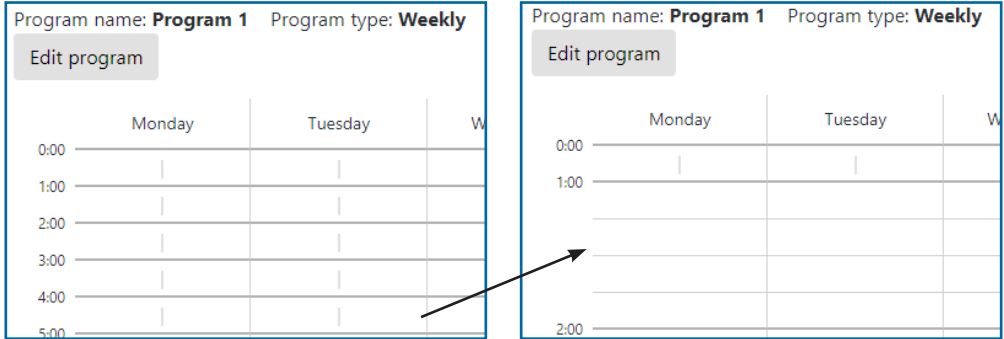

Once selected the desired time of an event, just click on the table cell to see the setting window

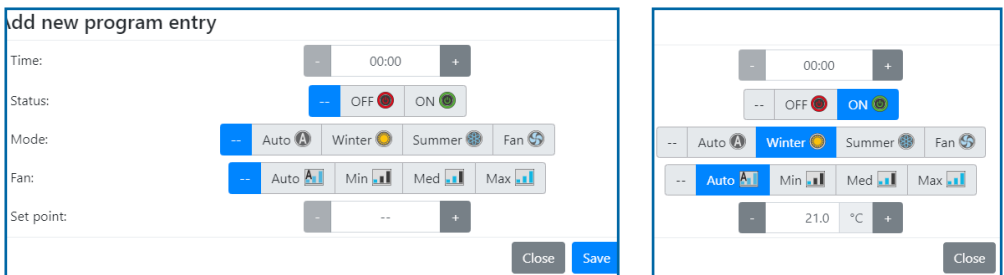

It is possible to set only the parameters to modify. Those with the icon “...” do not be changed during the program execution. The parameter variation depends from the type of the unit on which the program will be executed.

Saved parameters will be shown in the table.

The date and time lines with events remain expanded for a better visualization.

Each cell can be modified by simply clicking on it.

In the edit mask it's also possible to remove or duplicate in different positions a cell.

	Monday	Tuesday	Wednesday
0:00			
1:00			
2:00			
3:00			
4:00			
5:00			
6:00			
7:00			

	20°C	20°C	20°C
--	------	------	------

To duplicate a single option, click on it and press the copy button. Now click on the table to insert whatever copies of the desired option you want.

The “Confirm” button lets save the inserted copies. Otherwise the “Undo” button eliminates them.

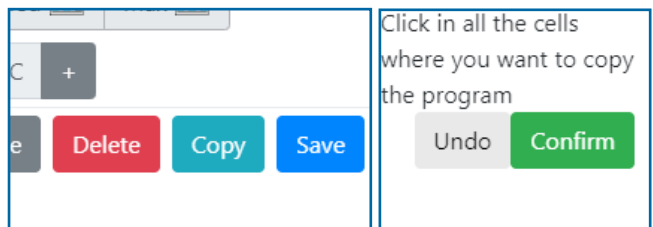

Otherwise it is possible to copy an entire day for a quick filling. Select "Day to copy" from the "Program" screen. A window will appear to select the day to copy and fix .

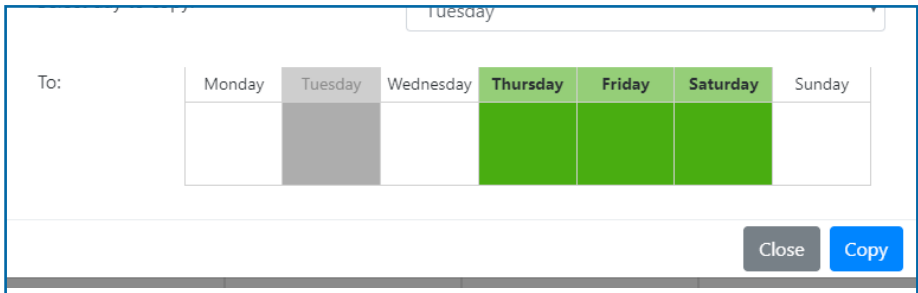

All programs created are listed into the left column.

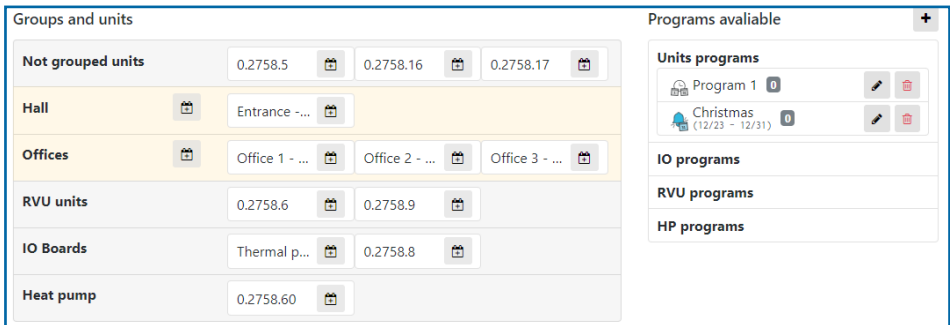

After the necessary programs are created, they must be assigned to the chosen groups or units. Weekly programs can only be assigned to groups or individually to units not assigned to groups (if any available). Each group or unit can only have one weekly program assigned. Special programs can be assigned both to groups and to each unit, with no limits.

To assign a program just click on the calendar icon of the group or of a unit. A window to select the desired program will appear:

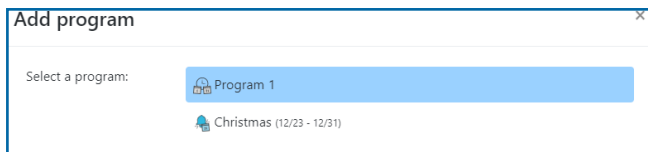

After the saving, the program will appear under the group or the selected unit.

Groups and units		Programs available	
<b>Not grouped units</b>		<b>Units programs</b>	
0.2758.5	0.2758.16	Program 1 4	
0.2758.17	Christmas (12/23 - ...)	Christmas (12/23 - 12/31) 2	
<b>Hall</b>		<b>IO programs</b>	
Program 1	Entrance - ...	<b>RVU programs</b>	
<b>Offices</b>		<b>HP programs</b>	
Program 1	Office 1 - ...		
	Office 2 - ...		
	Office 3 - 0.2758.3		
	Christmas (12/23 - ...)		

In this case to the not assigned unit 0.2758.17 has been assigned the “Christmas” special program.

To the boxes “Common Ares” and “Offices” has been assigned the “Program 1” weekly program and also to the unit “Office 3” the “Christmas” special program.

The program list in the right column shows the number of units that use each single program.

## Alarms

Select "Alarms" from the menu bar.

The main window shows a double list: the first one displays ongoing alarms the second historical data. The Energy Genius heat pump alarms are not managed.

Date time	Unit name	Unit group	Alarms
Fri, 11/16/2018, 11:32 AM	<u>Office A2 - 0.0.2</u>	Offices	✔
Fri, 11/16/2018, 11:31 AM	<u>Office A2 - 0.0.2</u>	Offices	⚠ T1 fault
Fri, 11/16/2018, 10:50 AM	<u>Thermal power plant - 0.0.7</u>		⚠ Pump 1 Fail, Boiler Fail
Fri, 11/16/2018, 10:29 AM	<u>0.0.5</u>		⚠ T1 fault
Fri, 11/16/2018, 10:28 AM	<u>0.0.17</u>		⚠ Flap board KO

The alarm are shown with a red icon and exclamation point. Once solved, their icon will be green with a flag.

You can click on the name of a unit to apply a filter to see only the data related to that unit

Active filter: 0.0.2 

Date time	Unit name	Unit group	Alarms
Fri, 11/16/2018, 11:32 AM	<u>Office A2 - 0.0.2</u>	Offices	✔
Fri, 11/16/2018, 11:31 AM	<u>Office A2 - 0.0.2</u>	Offices	⚠ T1 fault

Click the upper icon "X" to remove the filters.

In the section "Alarm Notifications" you can set the parameters of Sabiana Cloud to send eMail messages related to the alarms detected on the area

Tipo di evento	eMail	
Unit with alarm [any]	On activate sent: <input type="text" value="immediately"/>	Send on deactivate: <input type="text" value="Yes"/>
Unit with condensations alarm	On activate sent: <input type="text" value="never"/>	Send on deactivate: <input type="text" value="No"/>
Unit with probe alarm	On activate sent: <input type="text" value="never"/>	Send on deactivate: <input type="text" value="No"/>
Unit lost	On activate sent: <input type="text" value="immediately"/>	Send on deactivate: <input type="text" value="Yes"/>
0.2758.7.3	On activate sent: <input type="text" value="never"/>	Send on deactivate: <input type="text" value="No"/>
0.2758.7.4	On activate sent: <input type="text" value="never"/>	Send on deactivate: <input type="text" value="No"/>
		<input type="button" value="Save"/>

For each event (IO inputs defined as alarms included) is possible to send an e-mail at desired time intervals (immediately or after 1, 3 or 6 hours).

You can also choice to receive a message once the alarm is off.

The setting is validate only for the current user and the notifications will be sent to the desired e-mail address during the login phase.

## Report

Select “Report” from the menu bar.

In the upper part of the main window you can see 4 tabs that lead to corresponding reports:

- **Unit variations:** every minute logs the status variation (ON/OFF, mode, fan speed and setpoint) of the available units.
- **IO variations:** every minute logs the status of inputs and outputs of the available I/O boards.
- **Program Execution:** logs all the commands that are sent to the units according to the weekly and special programs inserted.
- **Temperature Diagrams:** lets the visualization of the temperature trend, rated from the unit probes.

For all tables the last 20 day records and the filter for units as the alarm ones are available.

## Administration

Select “Admin” from the menu bar.

A list of all configurations for the current account is available. The current set is highlighted at the top.

The screenshot displays the 'Plants' management page. At the top, there is a green button labeled 'Add new web gateway'. Below it, the 'Demo [Active]' configuration is shown. The 'Web gateway' section includes the following details: 'aaaaaaa', 'Web gateway ID: SAWA20D2GU', 'Location: Italy, Vimercate', 'IP: 79.6.221.172 V: 0.10', 'ISP: Telecom Italia Business', and 'Heat pump: Enabled'. To the right of this text is a bar chart titled 'Updates/m' showing data from 11-Nov to 16-Nov. Below the chart is a list of users: 'alessandro@techand.it Sabiana User (Manager)', 'niccolo.servidio@gmail.com Niccolò Servidio (Manager)', 'demo@sabiana.cloud Demo Sabiana [Sabiana] (User)', and 'bonfanet@gmail.com Alex Bonfa (User)'. At the bottom, the 'Remote assistance' section shows it is 'Disabled' and 'Enabled by Sabiana User @ 10/16/18, 12:44 PM' and 'Disabled at 10/16/18, 1:56 PM'. There is also a note about 'Technical support accesses'.

All the pieces of information about the used Web Gateway are available, with a diagram showing the number data sent from the setting to the cloud within the last 7 days.

It is possible to rename the setting with the “pencil” and also to rename the single Web Gateway. It is possible to force the remote reset for each Web Gateway with the “refresh” button or to force a new discovery by deleting the historical data with “refresh + bin” buttons. These last function is to be used only in case of heavy changes to the setting.

## Edit web gateway

Web gateway name:

Web gateway 1

Enable heat pump:



In the window to modify the name of the Web Gateway there is a flag to activate the Energy Genius heat pump. It is possible to activate only one Web Gateway for each setting.

The image shows a 'User info' dialog box with a close button (X) in the top right corner. It displays the following information: Username: alessandro@techand.it, Name: Sabiana, Surname: User. Below this, there are three radio button options for user roles: 'User', 'Manager' (which is selected), and 'Authorization Refused' (which is highlighted in red). At the bottom left is a 'Close' button, and at the bottom right is a blue 'Save' button.

For each user a modify window is available. It lets the choice of level access. Included the case when a user chooses to apply special permissions.

The user can have normally access to the same Web Gateway with whom they asked for the access to the configuration. Anyway it is possible to remove this limitation and let the access to the whole configuration. Otherwise further restrictions can be added, in terms of limitations to the groups or single machines.

With this management it is possible to ask the cloud for logging the single user of a machine, as for example an office owner, giving him permissions related to the only unit available in the area. In this way the user will control the indoor temperature of his office easily with his smartphone. In the same way it is possible to assign to one single or to more users a defined group of machines, in order to manage for example an open space.

**NOTE:**

**NOTE:**

