



CARISMA **WHISPER**
Residential Fan Coil Unit





CARISMA **WHISPER**

Where and why

For the air-conditioning of residential and work ambients (offices, shops, restaurants and hotel rooms, etc.) into which a reduced dimension, energy efficiency, modern aesthetic and silent operation are required.

The strengths



BEAUTIFUL

modern design



COMPACT

reduced dimension



SMART

low energy consumption



SILENT

basse emissioni sonore

MV version for wall installation only
126 mm depth

IV version for concealed installation

The motor

The latest synchronous inverter driven BLAC brushless and sensorless electronic motor with permanent magnets is controlled by an Inverter board designed and developed in Italy.

The electronic board is directly fitted on the motor.

Comfort and energy efficiency

The air flow can be varied continuously with a 1-10 V signal.

This lets:

- _improvement of the acoustic comfort
- _a more punctual reply to the variation of the thermal loads
- _greater stability of the requested ambient temperature.

Extreme efficiency, also at a low speed

Great reduction in electric consumption: with absorption values, under normal operating conditions, that are no greater than 5 Watt.

Quiet operation

The excellent values in terms of sound levels have been maintained in all working conditions, without any resonance phenomenon at any frequency.



Main components

5 sizes

from 75 to 645 m³/h

2 versions

for wall and for concealed installation, with 2 row coil

Outer casing

Made of:

_ front panel of plasticised stainless-steel plate

_ sides and supply grid of high-strength plastic material, of UL 94 HB extinguishing type

The air diffuser, that is placed over the top of the unit, is of adjustable type.

White RAL 9003.

Inner casing

Made of 1 mm galvanized steel, a rear panel and two lateral sides insulated with 3 mm polyolefin (PO) foam (class M1).

Filter

Polypropylene cellular fabric regenerating filter.

The filter frame, made of synthetic material, is inserted into special plastic sliding guides fastened to the internal structure for easy insertion and removal of the filter.

Fan assembly

Made of plastic tangential fan with anti-vibration fins. The fan hub, dynamically and statically balanced, is directly secured onto the motor shaft.

Electronic motor

Electronic motor with three phase permanent magnet brushless electronic motor that is controlled with reconstructed current according to a BLAC sinusoidal wave. The inverter board that controls the motor operation is powered by 230 Volt, single-phase and, with a switching system, it generates a three-phase frequency modulated, wave form power supply.

The electric power supply required for the machine is therefore single-phase with voltage of 230 - 240 V and frequency of 50 - 60 Hz.

Coil

It is manufactured from drawn copper tube and the aluminium fins are mechanically bonded onto the tube by an expansion process.

The coil has two Ø 1/2 inch BSP internal connections. The coil has Ø 1/8" inch BSP air vent and drain.

Condensate collection tray

Made of plastic (ABS UL94 HB) and fixed to the internal structure. The outside diameter of the condensate dis-charge pipe is Ø 15 mm.

CARISMA WHISPER

Electronic controls

All the Carisma Whisper units can be supplied with a wide range of electronic controls, fitted on the unit or for wall installation, that allow to control one single unit or, in case of the wall controls, several groups of units (with the use of power unit).

The room temperature can be controlled through electronic room thermostats, with different solutions according to every ambient conditions.

The Sabiana electronic room thermostats regulate the room temperature precisely and are suitable when the user wants to set the fan speed.

It is also possible to manage the fan coil units via direct bluetooth or wi-fi via cloud.

Controls fitted on the unit

- _ CB-E: Control fitted on the unit manual speed switch (to be used only with UP-ECO)
- _ CB-Touch: Touch control fitted on the unit with automatic speed switch with electronic thermostat and summer/winter switch
- _ UP-ECO: Power unit for CB-E control fitted on the unit
- _ UP-Touch: Power unit for CB-Touch control fitted on the unit
- _ T2: Sensor of NTC type (to be used as Change-over with UP-Touch power unit)
- _ T1-T3: T1-T3 air/water sensor kit



Wall controls

- _ WM-AU: Automatic speed switch with electronic thermostat and summer/winter switch (to be used only with UP-Touch)
- _ T-MB: T-MB wall control with display (to be used only with UP-Touch)
- _ UP-Touch: UP-Touch power unit for WM-AU and T-MB remote control
- _ T2: Sensor of NTC type (to be used as Change-over for UP-Touch power units)

Accessories

- _ PAP-F: Feet
- _ V2-F: 2 way valve Kit (all sizes)
- _ V3-F: 3 way valve Kit (all sizes)
- _ CBF-A/B/C: Breeze aesthetic frame Kit (sizes 2/3/4)
- _ IBF 2/3/4: Breeze recessed box Kit (sizes 2/3/4)

Control symbols



On / Stand by



Summer operation



Winter operation



Night mode



Ventilation mode and speed



Automatic ventilation operation



Dimensions

MV version

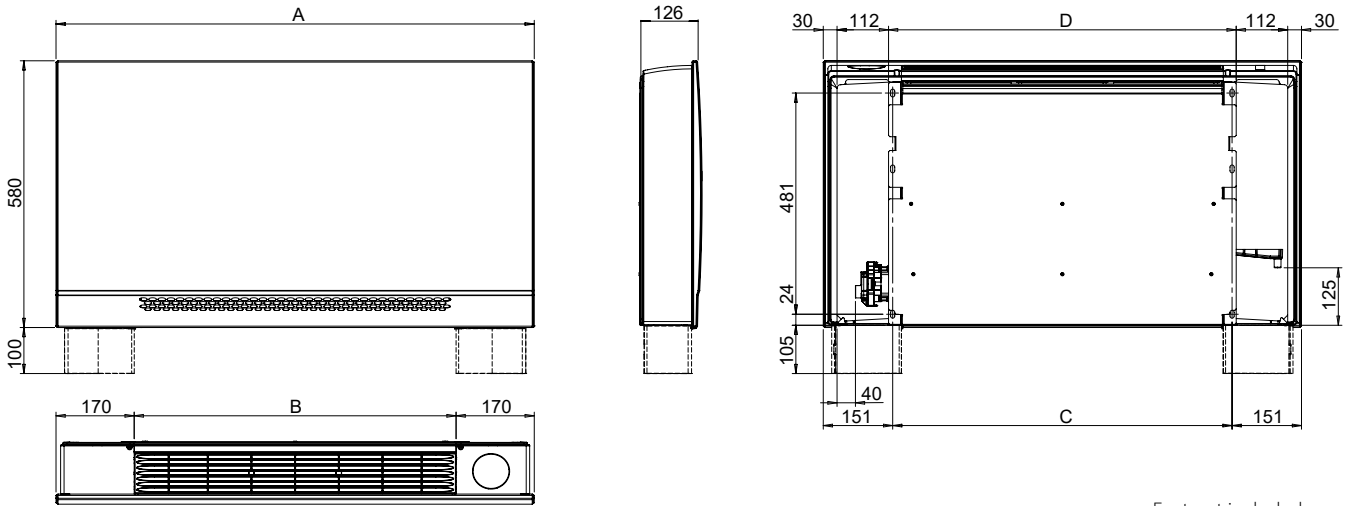

Feet not included

Model	CFF-ECM 10	CFF-ECM 20	CFF-ECM 30	CFF-ECM 40	CFF-ECM 50
A (mm)	640	840	1040	1240	1440
B (mm)	300	500	700	900	1100
C (mm)	338	538	738	938	1138
D (mm)	356	556	756	956	1156

BREEZE frame kit for wall concealed installation

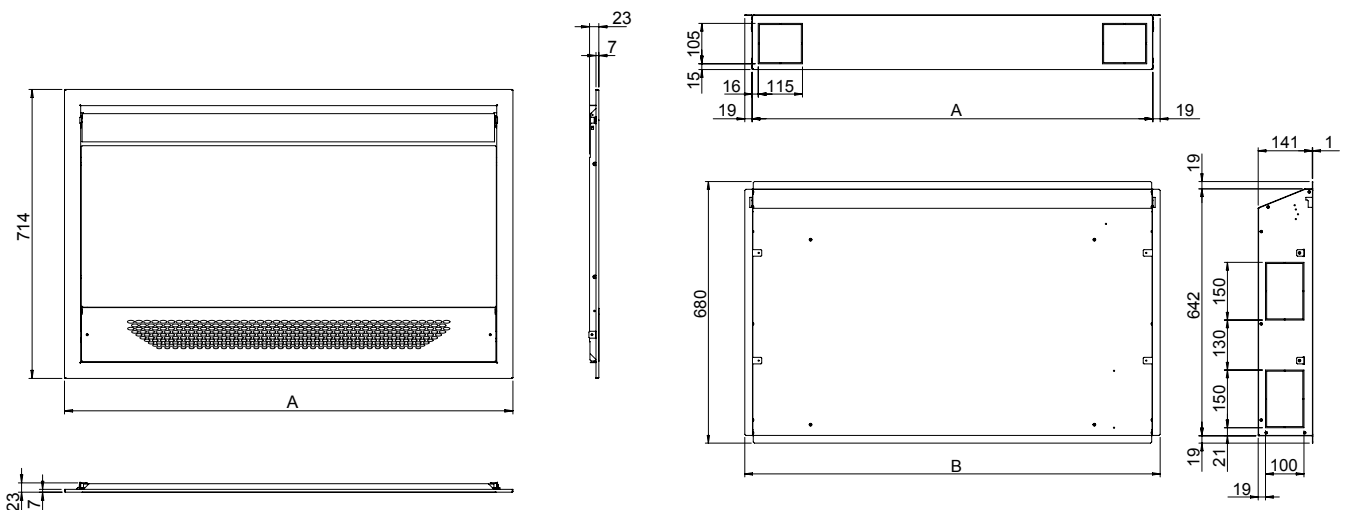

Model	A	ID
CFF-ECM 20	908	CBF-A
CFF-ECM 30	1108	CBF-B
CFF-ECM 40	1308	CBF-C

Model	A	B	ID
CFF-ECM 20	842	880	IBF 2
CFF-ECM 30	1042	1080	IBF 3
CFF-ECM 40	1242	1280	IBF 4

* For all other dimensions, see the Technical Guide

CARISMA WHISPER

Main performance

The following standard rating conditions are used:

Cooling (summer operation)

Entering air temperature: +27 °C d.b., +19 °C w.b.

Water temperature: +7 °C entrata, +12 °C uscita

Heating (winter operation)

Entering air temperature: +20 °C

Water temperature: +45 °C E.W.T, +40 °C L.W.T

MODEL		CFF-ECM 10						CFF-ECM 20						CFF-ECM 30					
Inverter power		1	2	3,5	5	7,5	10	1	2	3,5	5	7,5	10	1	2	3,5	5	7,5	10
		MIN			MED		MAX	MIN			MED		MAX	MIN			MED		MAX
Air flow	m ³ /h	75	90	110	130	170	205	125	145	175	205	255	305	190	225	270	315	395	470
Cooling total emission	kW	0,40	0,48	0,58	0,66	0,80	0,92	0,67	0,83	1,01	1,15	1,39	1,62	0,92	1,08	1,56	1,91	2,30	2,61
Cooling sensible emission	kW	0,30	0,36	0,44	0,52	0,64	0,75	0,50	0,62	0,76	0,88	1,08	1,28	0,67	0,79	1,15	1,41	1,72	1,99
Heating emission	kW	0,55	0,60	0,68	0,78	0,96	1,10	0,97	1,01	1,16	1,32	1,57	1,81	1,52	1,62	1,85	2,10	2,53	2,90
Dp Cooling	kPa	4,9	6,0	7,5	9,1	12,0	14,7	3,1	3,6	4,3	4,9	6,1	7,4	4,5	5,4	8,6	11,5	15,2	18,6
Dp Heating	kPa	6,1	6,7	8,0	9,6	13,0	16,2	3,7	3,9	4,4	5,0	6,1	7,3	7,1	7,7	9,2	11,0	14,6	18,2
Motor power input	W	3,2	3,5	4,2	5,2	7,4	10,3	3,7	4,0	4,9	6,3	9,5	14,0	4,1	4,8	6,3	8,6	14,1	21,6
Sound power (Lw)	dB(A)	31	33	36	40	45	50	30	33	38	42	47	52	32	34	39	43	47	53
Sound pressure (Lp) ⁽¹⁾	dB(A)	22	24	27	31	36	41	21	24	29	33	38	43	23	25	30	34	38	44
		CFF-ECM 10: suitable for ambients whose surface ranges from 7 until 11 mq approx.*						CFF-ECM 20: suitable for ambients whose surface ranges from 11 until 17 mq approx.*						CFF-ECM 30: suitable for ambients whose surface ranges from 17 until 26 mq approx.*					

MODEL		CFF-ECM 40						CFF-ECM 50											
Inverter power		1	2	3,5	5	7,5	10	1	2	3,5	5	7,5	10	1	2	3,5	5	7,5	10
		MIN			MED		MAX	MIN			MED		MAX	MIN			MED		MAX
Air flow	m ³ /h	220	260	320	380	480	575	255	300	365	430	535	645						
Cooling total emission	kW	1,14	1,45	2,06	2,50	2,97	3,36	1,44	1,95	2,55	2,92	3,37	3,81						
Cooling sensible emission	kW	0,82	1,05	1,48	1,80	2,17	2,49	1,04	1,40	1,82	2,10	2,47	2,83						
Heating emission	kW	1,79	1,91	2,23	2,58	3,13	3,62	2,19	2,25	2,61	3,00	3,60	4,20						
Dp Cooling	kPa	7,3	10,2	17,3	23,7	31,7	39,1	4,6	6,4	9,1	11,2	13,9	16,9						
Dp Heating	kPa	11,7	12,9	16,3	20,6	28,3	36,2	6,4	6,6	8,0	9,7	12,8	16,2						
Motor power input	W	4,7	5,4	7,2	9,9	16,4	25,4	5,3	6,1	8,2	11,4	19,0	29,5						
Sound power (Lw)	dB(A)	33	37	41	45	51	55	34	38	42	46	51	55						
Sound pressure (Lp) ⁽¹⁾	dB(A)	24	28	32	36	42	46	25	29	33	37	42	46						
		CFF-ECM 40: suitable for ambients whose surface ranges from 21 until 32 mq approx.*						CFF-ECM 50: suitable for ambients whose surface ranges from 24 until 36 mq approx.*											

(1) The sound pressure levels are 9 dB (A) lower than the sound power levels, apply to the reverberant field of a 100 m³ room and a reverberation time of 0.5 sec.

*surface in mq (square meters) defined with an air flow rate equal to 6 volume/hour at the medium speed (reduced surface, favouring the noiselessness) or at the maximum speed (maximum surface, favouring the compactness), for 3 m high ambients

Follow us on



Sabiana app



SABIANA SpA

Società a socio unico
via Piave 53 - 20011 Corbetta (MI) Italia
T. +39 02 97203 1 r.a.
F. +39 02 9777282
info@sabiana.it
www.sabiana.it

A company of Arbonia Group
ARBONIA ▲

