



Vertical Energy Plus

Recovery unit

TECHNICAL LEAFLET

Vertical Energy Plus

Recovery unit



The Energy Plus Vertical versions high-efficiency heat recovery ventilation units are designed to provide centralised air exchange service in commercial environments or residential blocks, complying with ErP 2018 requirements and ensuring high standards of fresh air filtration.

The Energy Plus Vertical units are full fresh air units and are designed to guarantee almost absolute separation of the supply and extraction flows and maximum heat recovery, thanks to the use of static counterflow aluminium plate heat exchangers.

The Energy Plus Vertical versions includes 4 sizes, suitable for floor to wall installation, and covers a range of flow rates from 1100 to 3850 m³/h.

All the standard units are equipped with the adjustment and control system according to the most advanced logics available in the sector.

Fan adjustment is available with constant flow control, a recommended solution for single zone ventilation system applications, and with constant differential pressure control, a recommended variable air flow rate solution in multi-zone applications with adjustment dampers dedicated to individual zones.

External casing. Structure made up of aluminium frame with Sabiana double recess profile and sandwich panels with double sheet and polyurethane foam insulation.

The 35 mm thick aluminium profiles are shaped to guarantee the double recess of the panels, perfect flatness and maximum ease of cleaning the internal surfaces.

The panels are supplied with a thixotropic gasket that allows the best continuity of the seal towards the outside.

Special attention is paid to internal sealing and insulation in order to avoid any contamination of flows.

Fans. The units are supplied with electronic plug fans equipped with EC synchronous motors with very high electrical efficiency.

The design of the impellers is of the backward curved blade type in order to minimize water leakages.

The design of the supply section is such as to optimize the flows inside and obtain high levels of ventilation efficiency while minimizing inefficiencies and noise.

The fans allow the units to reach available static pressures up to 1000 Pa. Such high pressures may be required in the case of particularly complex multizone applications where, for example, different fire compartments are crossed.

Fans are equipped with a pressure probe on the calibrated nozzle of the fan used in the case of control aimed at the target flow rate.

Heat exchangers. The units are supplied with static counterflow heat exchangers with aluminium plates that have been sized to meet the requirements of the ErP 2018 regulation for ventilation units, both to minimize the pressure drops occurring inside the units and to maximize the heat recovery efficiencies within the expected range of operating flow rates (EN 308 efficiency up to 85% in dry conditions).

The choice of the exchanger is strategic in order to guarantee, besides the energy recovery, also the absence of contamination between the flow that carries the exhaust air, breathed by the internal occupants, and the fresh air coming from outside.

By-pass damper. The units are equipped with by-pass duct in line with the heat exchanger and with damper modulating 100% of the air flow between the path crossing the heat exchanger for heat recovery and the path avoiding it, passing through the same by-pass duct.

In this way the unit can take full advantage of the free air conditioning capacities of the fresh air if available, without affecting the inlet temperature into the environment due to undesired heat recovery.

Filters. As proof of the maximum attention paid to the cleanliness of the inlet air and to safeguard the durability of the internal equipment, the units are fitted as standard with ISO ePM₁ 55% filters on the fresh air flow and ISO ePM₁₀ 55% filters on the outlet flow.

In compliance with the ErP 2018 regulation, in order to facilitate routine maintenance operations, each filtration section is equipped with a differential pressure switch with alarm signal return to the panel.

Adjustment and control system. The units are fully equipped with the necessary electronics and sensors for operational use.

Electric heaters. In the case of application in particularly rigid climatic conditions, the units are also available in a version with integrated electric heater.

The integrated heaters are of the modulating type with the aim of maintaining the air outlet temperature outside the risk of freezing.

Post treatment

By using the ENY-PV Manager software it is possible to set the management of hydronic or electric coils for the unit outlet temperature control (not supplied by Sabiana) it is possible to set a modulating control and/or an ON/OFF.

Dimension and weight

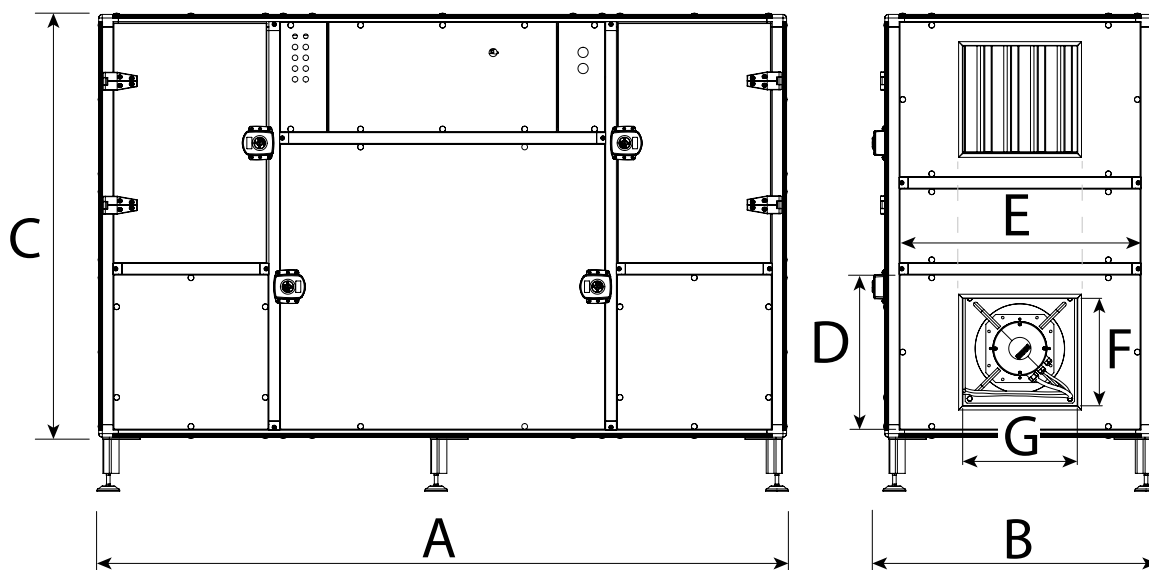

Model	A (mm)	B (mm)	C (mm)	D (mm)	E (mm)	F (mm)	G (mm)	Weight kg
ENY-PV2	1920	790	1180	433	673	300	320	220
ENY-PV3	2110	1110	1380	443	993	330	450	300
ENY-PV4	2300	1310	1480	443	1193	330	650	400
ENY-PV5	2300	1310	1750	578	1193	465	850	475

Note: the feet can be adjusted from min. 150 mm to max. 200 mm.

Nominal technical data

	Udm	ENY-PV2	ENY-PV3	ENY-PV4	ENY-PV5
Nominal flow rate	m ³ /h	1100	2000	3000	3850
Nominal available static pressure	Pa	500	500	500	600
EN308 efficiency	%	84,4	84,2	84	83
Sound power level radiated by the enclosure LwA	dB(A)	71,3	70,7	73,8	77,8
Input/output flow	dB(A)	82,3	81,7	84,8	88,4
Extraction flow/fresh air intake	dB(A)	76,3	75,7	78,8	82,4
Optional internal heater	kW	4	8	11	13
Standard power consumption (without heater)	-	230-1+N/50Hz		400-3+N/50Hz	
	kW	1,2	1,7	2,6	3,8
Filtration efficiency	-	EN 779 F7 / M6 ISO 16890 ePM ₁ 55% / ePM ₁₀ 55%			
Dimensions	mm	1920x755x1180	2110x1075x1380	2300x1275x1480	2300x1275x1750

Factory versions

Left Configuration

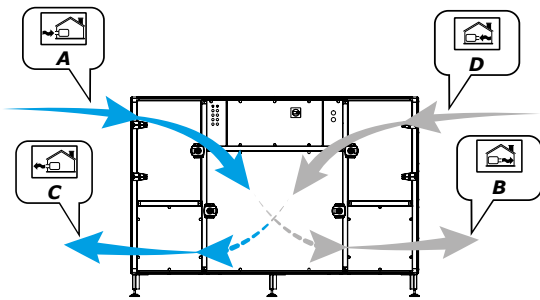

Right Configuration

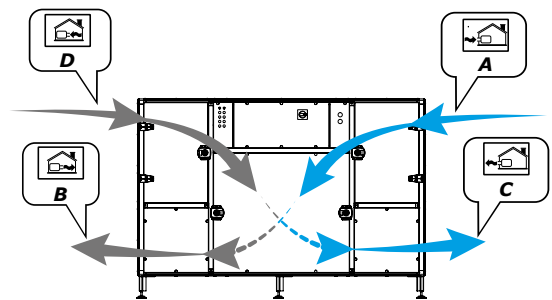

A = Fresh air

B = Supply air

C = Exhausted air

D = Extract air

Side connection from factory or higher modified on the spot

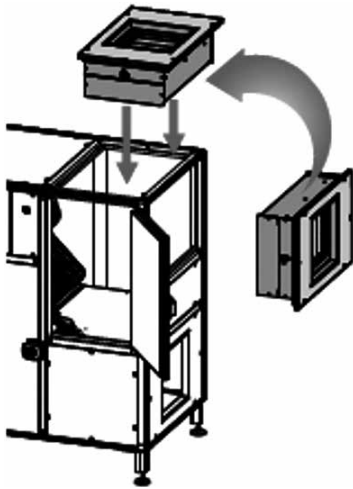

Openings for maintenance

Mechanical inspections

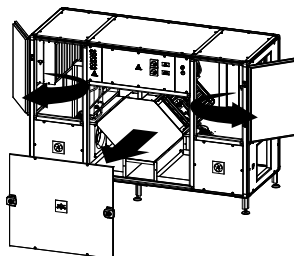

Electrical inspections

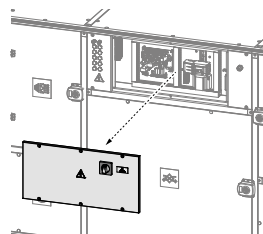

Filter replacement

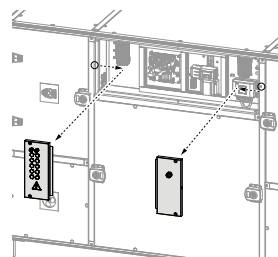
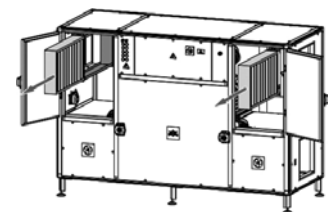

Typical curves

Units are available from the factory with target flow or differential pressure control.

The following diagrams show the flow rate/available static pressure curves of the units with cleaned filters at the different fan adjustment voltages.

The performance can be used as a reference for both the inlet flow with ePM₁ 55% filter and the outlet flow with ePM₁₀ 55% filter.

ENY-PV2

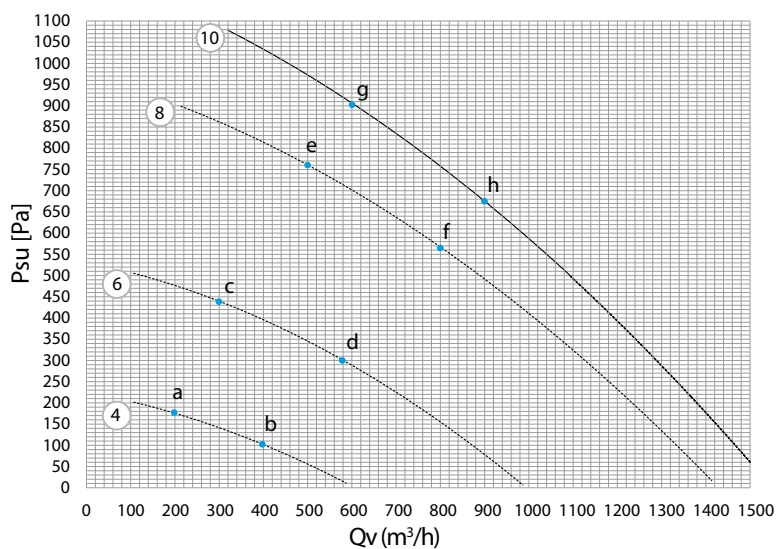

⊗ = control voltage
 Psu = available static pressure
 Qv = air flow

ENY-PV2		a	b	c	d	e	f	g	h
Lw irradiated	dB(A)	57,4	52,7	67,7	64,6	74,5	71,4	76,9	73,4
Lw supply	dB(A)	60,4	55,7	70,7	67,6	77,5	74,4	79,9	76,4
Lw intake	dB(A)	46,4	41,7	56,7	53,6	63,5	60,4	65,9	62,4

Performance and absorptions for single fan ENY-PV2

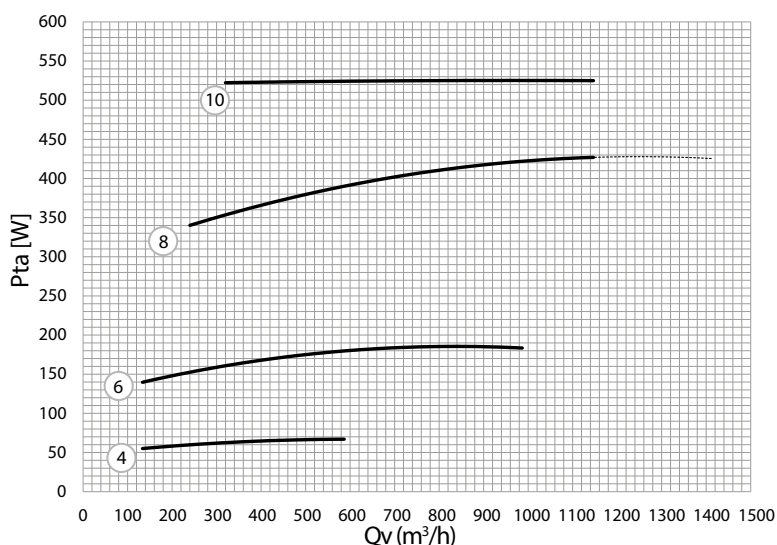

⊗ = control voltage
 Pta = power absorption
 Qv = air flow

ENY-PV3

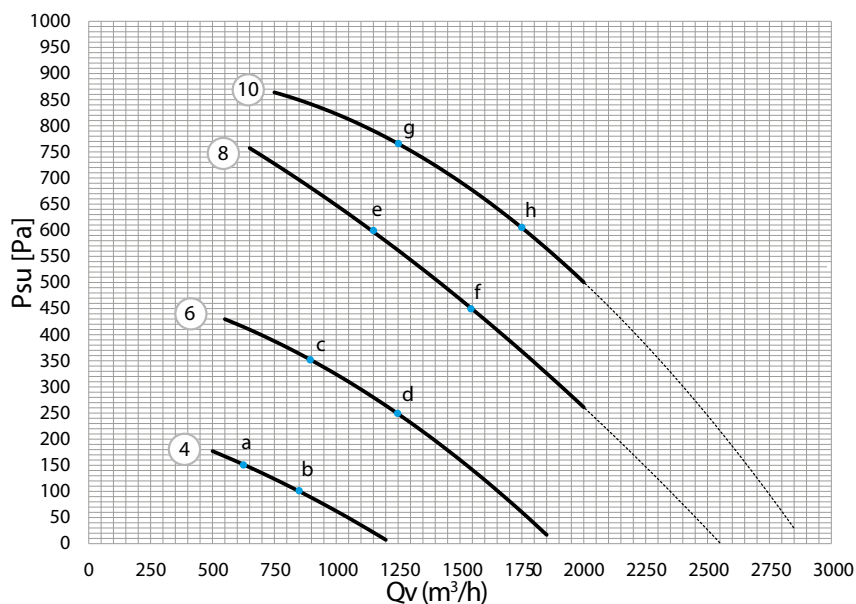

(X) = control voltage
 Psu = available static pressure
 Qv = air flow

ENY-PV3		a	b	c	d	e	f	g	h
Lw irradiated	dB(A)	59,1	54,9	68,3	63,2	72,8	68,8	75,0	71,7
Lw supply	dB(A)	62,1	57,9	71,3	66,2	75,8	71,8	78,0	74,7
Lw intake	dB(A)	48,1	43,9	57,3	52,2	61,8	57,8	64,0	60,7

Performance and absorptions for single fan ENY-PV3

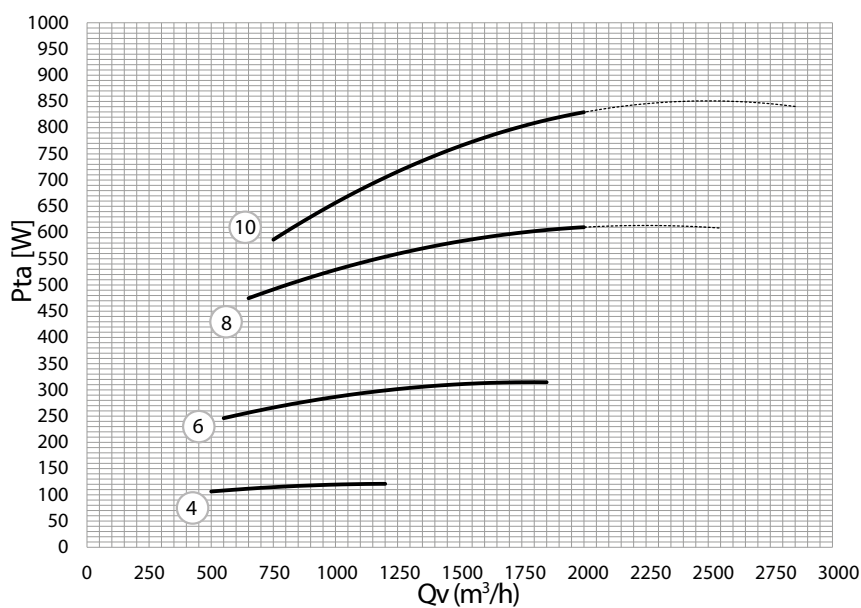

(X) = control voltage
 Pta = power absorption
 Qv = air flow

ENY-PV4

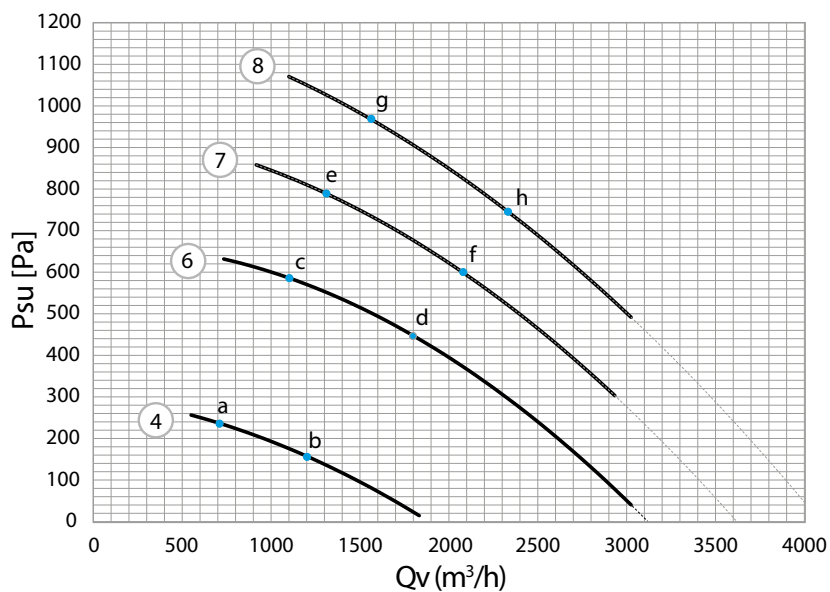

⊗ = control voltage
 Psu = available static pressure
 Qv = air flow

ENY-PV4		a	b	c	d	e	f	g	h
Lw irradiated	dB(A)	61,0	59,7	70,9	69,3	76,4	74,4	77,7	75,4
Lw supply	dB(A)	64,0	62,7	73,9	72,3	79,5	77,5	80,7	78,4
Lw intake	dB(A)	50,0	48,7	59,9	58,3	65,1	63,1	66,7	64,4

Performance and absorptions for single fan ENY-PV4

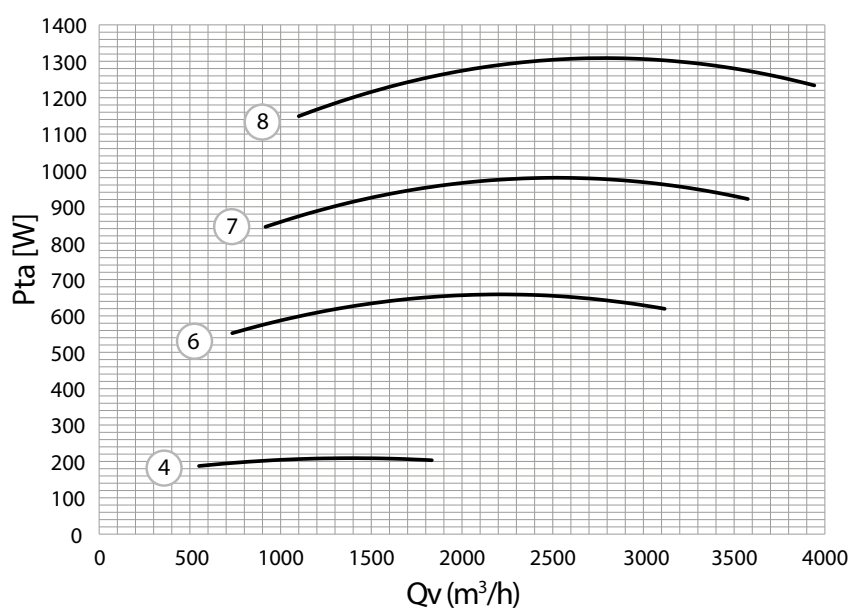

⊗ = control voltage
 Pta = power absorption
 Qv = air flow
 8 VdC max control voltage ENY PV4

ENY-PV5

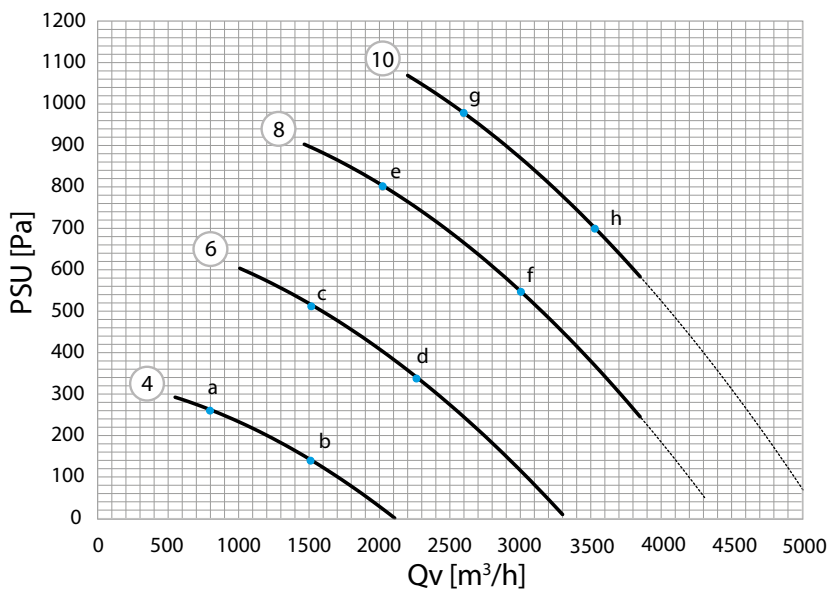

(X) = control voltage
 P_{su} = available static pressure
 Q_v = air flow

ENY-PV5		a	b	c	d	e	f	g	h
Lw irradiated	dB(A)	63,3	60,5	72,3	70,0	78,0	74,9	80,3	77,8
Lw supply	dB(A)	66,3	63,5	75,3	73,0	81,0	77,9	83,3	80,8
Lw intake	dB(A)	52,3	49,5	61,3	59,0	67,0	63,9	69,3	66,8

Performance and absorptions for single fan ENY-PV5

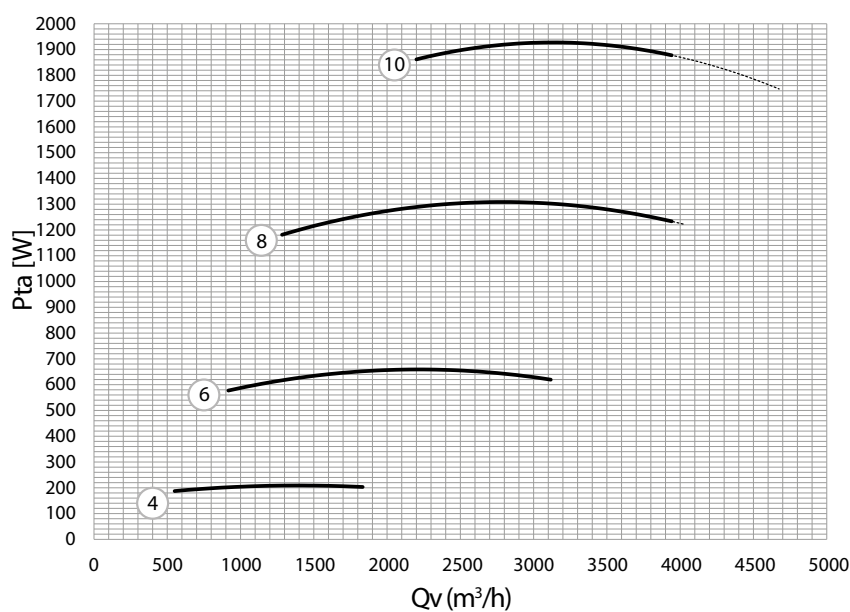

(X) = control voltage
 P_{ta} = power absorption
 Q_v = air flow

Annex EU 1253/14

Trade name of manufacturer	Energy Plus Verticale			
Manufacturer ID	ENY-PV2	ENY-PV3	ENY-PV4	ENY-PV5
Type HRS	Static Countercurrent			
Heat recovery efficiency (%)	84,40	84,20	84,00	83,00
Nominal flow rate of the NRVU (m ³ /s)	0,42	0,56	0,83	1,07
Effective electric power consumption (W)	1044	1580	2460	3650
SFP int (W/m ³ /s)	1384	1345	1280	1230
SFP int_lim 2018 (W/m ³ /s)	1400	1350	1290	1233
Nominal external pressure Δp_s , ext (Pa)	500	500	500	600
Front filtration speed at design flow rate (m/s)	2,040	1,633	2,011	1,892
Internal pressure drop of ventilation components Δp_s , int (Pa)	650,48	769,34	783,76	753,14
Static efficiency of fans used as per Regulation (EU) No. 327/2011	53,90	57,20	61,23	61,23
Declared maximum percentage of external leakage (%) EN 13141-7	< 2	< 2	< 2	< 2
Declared maximum percentage of internal leakage (%) EN 13141-7	< 3	< 3	< 3	< 3
Energy performance or preferably energy classification of filters	Fresh Air ePM ₁ 55% Indoor Air ePM ₁₀ 55%			
Description of the visual filter warning signal for NRVUs intended to be used with filters	<p>Each filtration section is equipped with a differential pressure switch that opens the circuit of an ohmic line directly reported to the electronic board.</p> <p>When the limit fouling is reached, beyond which it is advisable to replace the filter, the signal is perceived by the board and is sent back to the user interface display, with the indication of the signalling code.</p> <p>The filter replacement alarm is enabled for information purposes only and does not affect the functionality of the ventilation unit, which remains unchanged.</p>			
Sound power level at the enclosure (LwA)	71,30	70,70	73,80	77,80
Internet address with disassembly instructions	www.sabiana.it			
Fan efficiency for effective power calculation (%)	47	61	65	66
Filter front area filters (m ²)	0,207	0,340	0,414	0,565

- PL-LINK**
- Digital single-color liquid crystal wall control
 - Multi-screen display with menus selectable by buttons
 - Backlit screen
 - Features:
 - Ventilation mode setting
 - Selection and modification of the weekly programme
 - Management of warnings and alarms
 - Setting the clock
 - Standby



Modbus The Modbus RS485 protocol for integration into compatible BMS systems is available on request. .

ENY-PV Manager

ENY-PV Manager, a software tool for PC, necessary to modify the factory operative parameters, is available on the Sabiana webpage.

The tool can be used connecting the PC to the Ethernet port on the board and, using BACnet communication, achieves different levels of operation:

- Basic features:
 - Target value settings for custom flow rates or differential pressures
 - Weekly programme setting
 - Displays of status, warnings and alarms
 - Monitoring of unit operating variables
- Advances features:
 - Operative parameters change
 - Modification of electronic board configurations for addition of optional functions or maintenance operations with restoration

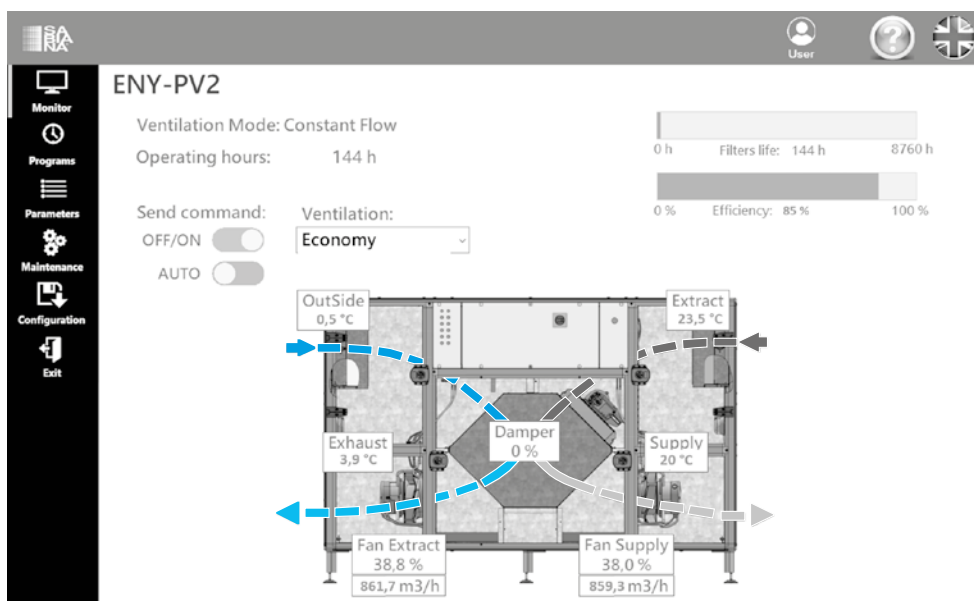



A company of Arbonia Group
ARBONIA ▲

Follow us on



Sabiana app



SABIANA SpA

Società a socio unico

Via Piave 53 - 20011 Corbetta (MI) Italia

T. +39 02 97203 1 r.a. • F. +39 02 9777282

info@sabiana.it

www.sabiana.it