

# INSTALLATION, USE AND ROUTINE MAINTENANCE MANUAL

# ENERGY-U plus

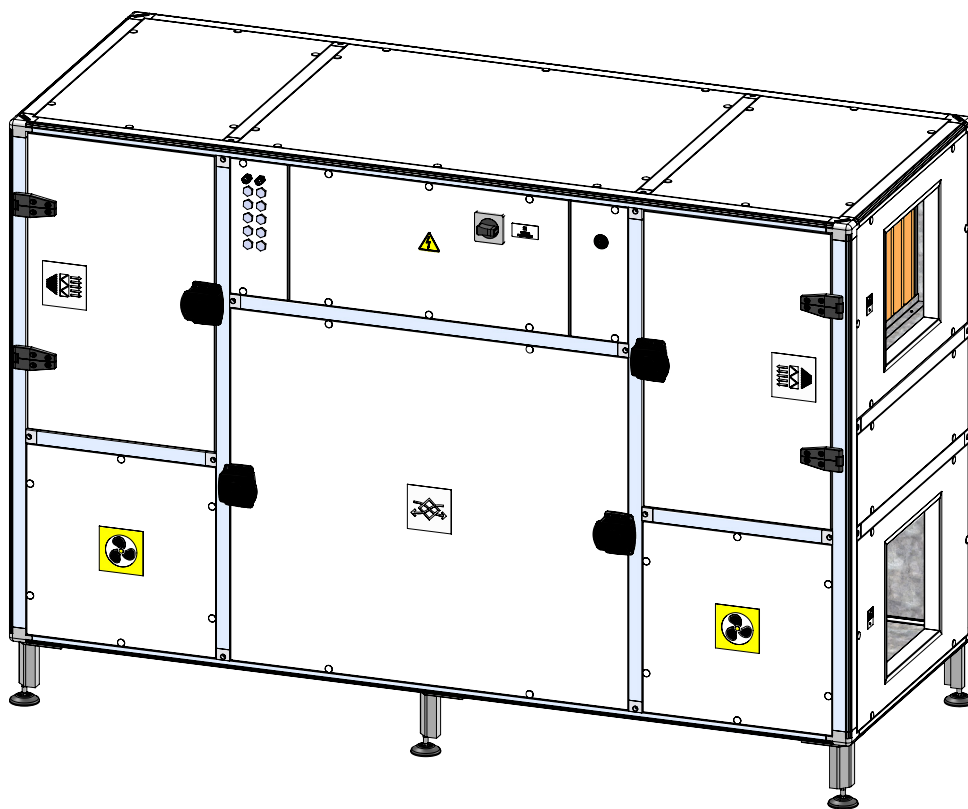

## *Ventilation Unit* **ENY-PV**

CE



**SABIANA**  
IL CLIMA AMICO

A company of Arbonia Group  
**ARBONIA** ▲

Via Piave, 53 · 20011 Corbetta (MI) · ITALY  
Tel. +39.02.97203.1 autom. ans. · Fax +39.02.9777282 - +39.02.9772820  
E-mail: [info@sabiana.it](mailto:info@sabiana.it) · Internet: [www.sabiana.it](http://www.sabiana.it)

03/21  
Code 4051323EN



**Carefully read the following instruction booklet** before starting up the machine.



Caution! Particularly important and/or delicate operations.



Operations that may be carried out by the user.



Interventions to **be** carried out **exclusively by an installer or authorised technician**.



Caution! Hot surface hazard

### ESSENTIAL SAFETY RULES

Children or disabled persons and without assistance are forbidden to use the unit.

The unit is designed to be used by expert or trained people in shops, in light industry and factories, or for commercial use by unqualified people.

It is dangerous to touch the unit with wet parts of your body and bare feet.

Do not perform any type of intervention or maintenance without first having disconnected the power to the unit.

Do not tamper with or modify the adjustment or safety devices without being authorised and without instructions.

Do not twist, detach or pull the power cords coming out of the unit even if not plugged in.

Do not pour or spray water on the unit.

Do not put anything into the air intake and supply grids.

Do not remove any protection without first having disconnected power to the unit.

Do not throw or leave any residual packing material within the reach of children as it is a potential risk of danger.

Do not install the unit in explosive or corrosive atmospheres, in moist areas, outdoors or in extremely dusty environments.

**CAUTION!** *The unit can only work with air, which must not contain substances harmful to health, flammable, explosive, aggressive, corrosive or dangerous in any other way, to prevent them from being diffused into the duct system or in the building and cause harm to health or even death.*

## SAFETY REQUIREMENTS



### » GENERAL INFORMATION

The unit can be used by children no younger than 8 years old and by persons with reduced physical, sensory or mental capabilities, or lack of necessary experience and knowledge as long as they are supervised or after they have received instructions regarding safe use of the unit and understanding the hazards related to it.

Children must not play with the unit.

Cleaning and maintenance to be carried out by the user cannot be done by children without supervision.

Before performing any operation, make sure that:

1. The unit is not live.
2. Install a circuit breaker switch in an easily accessible position near the unit or units.

For safety purposes, during installation, maintenance and repairs, abide by the following:

- Always wear work gloves.
- Do not expose to flammable gases.
- Do not place objects on the nozzles or connections.



Transport, handling, start-up and maintenance must be entrusted to specialised staff or to people who have been adequately trained and instructed on the type of work and the risks resulting from failure to comply with the safety standards.

Do not insert objects or your hands into the electric fan.

Do not remove the safety labels inside the unit. If illegible, have them replaced.

Always request original spare parts when replacing components.

In addition to the assembly and maintenance instructions, stickers are applied on the unit bearing indications, which must be observed with the same caution.

Make sure to earth the unit.



### » **FOR INSTALLATION:**

Do not install the unit in explosive or corrosive atmospheres, in moist areas, outdoors or in extremely dusty environments.

The installation site must be dry and suitably protected against humidity.

Upstream of the unit, provide an omnipolar switch with a contact opening distance that ensures complete disconnection in overvoltage category III conditions.

For safety purposes, during installation, abide by the following:

- The hoists and the lifting equipment must have an adequate capacity.
- Do not use faulty hoists and lifting equipment.
- Ropes, straps and similar lifting devices must not be knotted or come into contact with sharp edges.
- Forklifts, elevators and cranes must have an adequate capacity.
- Loads must not be suspended over people.
- Do not operate the fans until the air distribution ducts have been connected.

### » **FOR MAINTENANCE:**

The maintenance staff must observe all the accident prevention (safety) regulations in force.

Wear protective clothing and appropriate protective equipment to minimise the risk of accidents.

Before performing any operation, be sure to:

- 1 - Disconnect the electric power to the unit.
- 2 - Make sure that the fan has stopped.

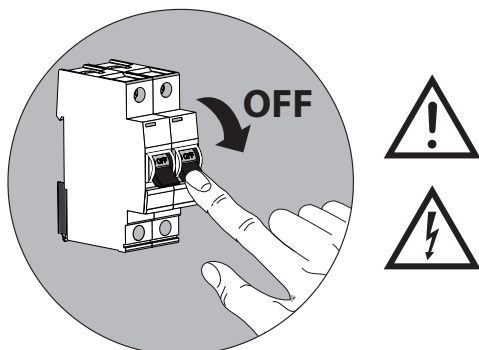

Do not tamper with or modify the adjustment or safety devices without being authorised.

All the panels and covers removed for the purpose of maintenance or repair must be re-installed at the end of the operations.

## SAFETY STANDARDS

In line with our policy of improvement, we always aim to provide state-of-the-art products compliant with current safety standards.

The rules and guidelines in this document, therefore, reflect compliance with the safety regulations and provisions that apply.

In addition to following the recommendations in this document, all staff potentially exposed to risks during the installation, use or maintenance of our equipment are strongly recommended to ensure that it complies with the relevant domestic safety regulations in force.

The CE marking and Declaration of conformity provided attest to the compliance of our products with the applicable Community legislation.

However, SABIANA declines all liability for personal injury or damage to property caused by the failure to apply these safety regulations or by unauthorised modification of the product.

When installation involves other products without CE marking, the relevant certification rests with the purchaser, who assumes full responsibility for the certification of conformity of the entire system.

The products are manufactured in accordance with the following guidelines:

- **Machinery Directive 2006/42/EC**
- **Low Voltage Directive 2014/35/EU**
- **Electromagnetic compatibility directive 2014/30/EU**
- **RoHS Directive 2011/65/EC**
- **Energy Related Products (ERP) Directive 2009/125/EC**
- **REACH EC Regulation 1907/2006**



**CAUTION!**

**DANGEROUS VOLTAGE. DO NOT PERFORM ANY OPERATION BEFORE DISCONNECTING THE POWER SUPPLY. WAIT AT LEAST 3 MINUTES AFTER DISCONNECTING THE VOLTAGE ON ALL POLES.**

**EVEN WHEN THE UNIT CIRCUIT BREAKERS ARE DISCONNECTED, ON THE INPUT TERMINALS OF THE EXTERNAL POWER SUPPLIES, THERE IS THE DANGER OF ELECTRIC SHOCKS THAT CAN COMPROMISE HEALTH OR HAVE FATAL CONSEQUENCES.**

## USE AND STORAGE OF THE MANUAL

This instruction manual is intended for the machine user, owner and technical installer and must always be available for consultation.

The manual is intended for the user, maintenance technician and installer of the machine.

The instruction manual indicates the intended use of the machine, its technical features and provides indications as to its correct use, cleaning and adjustments. It also provides important indications for maintenance, for residual risks and in any case to carry out operations with special care.

This manual must be considered as part of the machine and must be KEPT FOR FUTURE REFERENCE until the final scrapping of the machine.

The instruction manual must always be available for consultation and preserved in a dry and protected area.

Should it be lost or damaged, the user can request a new manual from the manufacturer or retailer, indicating the model and serial number of the machine displayed on its rating plate.

This manual reflects the state of technology at the moment it was drafted. The manufacturer reserves the right to update production and following manuals without being obliged to update previous versions as well.





The manufacturer will not be held liable in case of:

- improper use or misuse of the machine
- use nonconforming to that expressly specified in this publication
- serious shortcomings in intended and recommended maintenance
- changes to the machine or any unauthorised intervention
- use of non-original spare parts or not specific for the model
- total or partial failure to comply with the instructions
- Exceptional events

## UNIT IDENTIFICATION

There is an identification label on each unit bearing the data of the manufacturer and the machine type. (See Figure "A")

**NOTE:** other warning labels can be added on the product based on the analysis of additional/other risks.

  	
SABIANA S.p.A. Via Piave 53 - 20011 - Corbeta (MI) - ITALY	
MADE IN ITALY	230V 50Hz
HEAT RECOVERY	ENERGY PLUS
MODEL	ENY-PV-QER
CODE	00XXXXX
SIZE	1
MAX POWER INPUT	000 W
MAX CURRENT INPUT	0,0 A
INTERNAL PRE-HEATER ELECTRICAL DATA	
MAX POWER INPUT	000 W
MAX CURRENT INPUT	0,0 A
DATE	01.02.2020
 	

## PURPOSE

**BEFORE INSTALLING THE UNIT READ THIS MANUAL CAREFULLY.**

The unit cannot be used:

- for outdoor air treatment
- for installation in damp environments
- for installation in explosive atmospheres
- for installation in corrosive atmospheres

Operating limits:

- Power supply voltage:

**ENY-PV2:** 230Vac 50Hz

**ENY-PV3 / ENY-PV4/ ENY-PV5:** 400Vac 50Hz (3P+N)

- Power consumption: see the technical data plate
- The ventilation unit is set-up for temperatures of the intake air between -20°C and +40°C.
- Recommended maximum air pressure 1000Pa
- Protection rating of the unit is IP40.

## DANGER LABELS



These draw attention to the presence of live parts inside the casing on which the label is applied.



These draw attention to the presence of extremely hot parts. In case of contact, there is a risk of severe burns. Always leave it to cool down before starting any maintenance procedure (symbol 5041 of IEC 60417).

## DISPOSAL

- Product disposal: follow the environmental regulations in force.

• **Disposal of waste electrical and electronic equipment (WEEE), pursuant to European Directive 2012/19/EU (WEEE).**



(Applicable in countries with separate waste collection systems)

The symbol affixed to the product or documentation entails that, at the end of their service life, the products should not be disposed of with normal urban solid waste.

The crossed-out bin symbol is shown on all products to recall separate waste collection obligations.

## PACKAGING / TRANSPORT

### » PACKAGING

Each product is carefully inspected before shipment. Typically, the product is packed for transport on pallets. A protective film is usually also applied to minimise water infiltration.

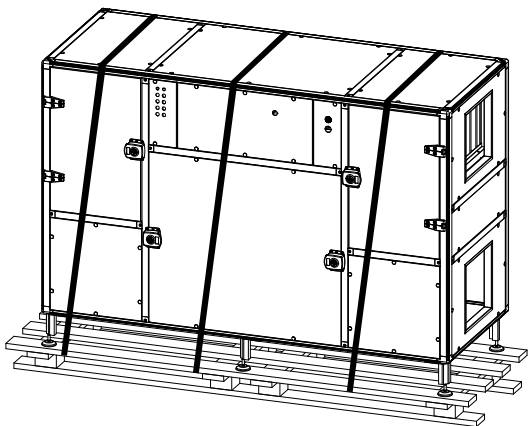

### » HANDLING, TRANSPORT AND UNLOADING

We decline all liability for damage to the units during the loading, unloading and transport operations. Before unloading the products, ensure that the transport/lifting device is suited to the weight and size of the same. Movements must be carried out without stressing the protruding accessories (connections, handles, hinges, etc.). Do not overturn the unit, to avoid breaking the supports, components. Do not subject the unit to violent blows that may compromise its integrity. If the loading, unloading and movement operations are carried out using a forklift truck with forks, these must not be shorter than the unit concerned, in order to ensure its stability.

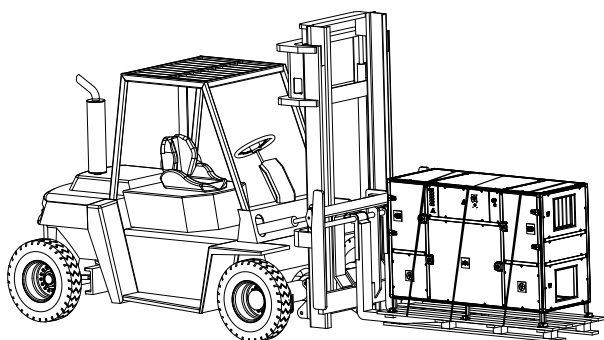

If the loading, unloading and movement operations are carried out by crane, lift the unit and put it in place with spacers, making sure the equipment is suited to the weight of the unit.

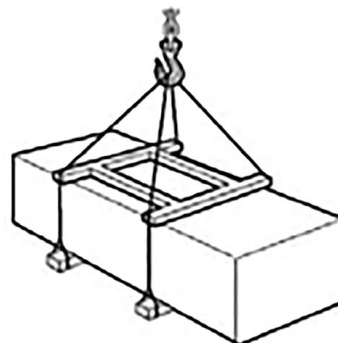

### » POST-TRANSPORT CONTROL

The unit must be inspected upon receipt of the goods to verify the absence of transport damage. If there is any damage or suspicion of damage to the unit, the recipient must report it to the carrier, who is held responsible for damage during transport. Transport packaging must be disposed of according to local regulations.

### » STORAGE

The ventilation unit must only be stored in dry rooms, at a temperature between  $-25^{\circ}\text{C}$  and  $+55^{\circ}\text{C}$ . If the unit remains stored for a long time, close all openings to prevent the penetration of air and water.

### » GENERAL NOTES UPON DELIVERY

The ventilation unit is supplied with the following parts:

- A. Instruction and maintenance booklet
- B. © Siemens **PL-Link** Control

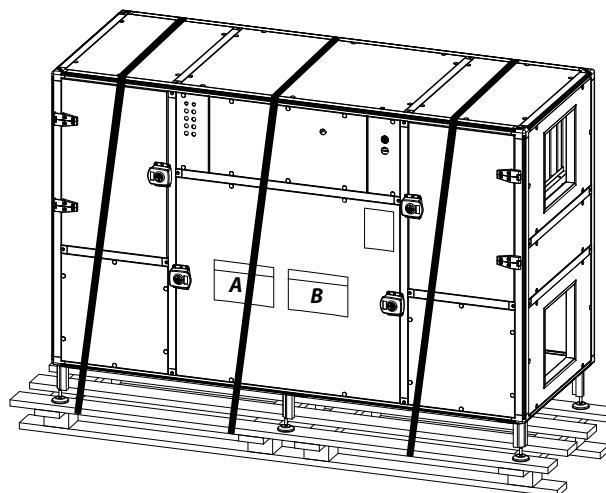

## RANGE

Product Code	Size	Maximum flow rate [m <sup>3</sup> /h]	Ventilation Control	Equipment Version	Setup Connections
ENY-PV2-QL	2	1100	Constant flow rate	/	Left
ENY-PV2-QR	2	1100			Right
ENY-PV2-QEL	2	1100		With Heater	Left
ENY-PV2-QER	2	1100			Right
ENY-PV2-DPL	2	1100	Constant differential pressure	/	Left
ENY-PV2-DPR	2	1100			Right
ENY-PV2-DPEL	2	1100		With Heater	Left
ENY-PV2-DPER	2	1100			Right
ENY-PV3-QL	3	2000	Constant flow rate	/	Left
ENY-PV3-QR	3	2000			Right
ENY-PV3-QEL	3	2000		With Heater	Left
ENY-PV3-QER	3	2000			Right
ENY-PV3-DPL	3	2000	Constant differential pressure	/	Left
ENY-PV3-DPR	3	2000			Right
ENY-PV3-DPEL	3	2000		With Heater	Left
ENY-PV3-DPER	3	2000			Right
ENY-PV4-QL	4	3000	Constant flow rate	/	Left
ENY-PV4-QR	4	3000			Right
ENY-PV4-QEL	4	3000		With Heater	Left
ENY-PV4-QER	4	3000			Right
ENY-PV4-DPL	4	3000	Constant differential pressure	/	Left
ENY-PV4-DPR	4	3000			Right
ENY-PV4-DPEL	4	3000		With Heater	Left
ENY-PV4-DPER	4	3000			Right
ENY-PV5-QL	5	3850	Constant flow rate	/	Left
ENY-PV5-QR	5	3850			Right
ENY-PV5-QEL	5	3850		With Heater	Left
ENY-PV5-QER	5	3850			Right
ENY-PV5-DPL	5	3850	Constant differential pressure	/	Left
ENY-PV5-DPR	5	3850			Right
ENY-PV5-DPEL	5	3850		With Heater	Left
ENY-PV5-DPER	5	3850			Right

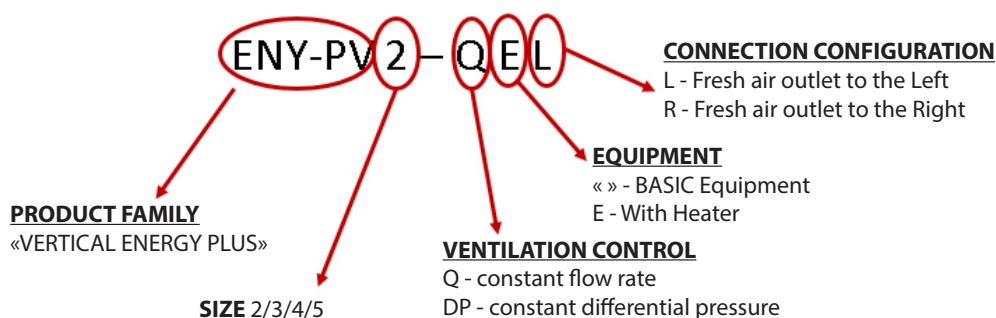

## DIMENSIONS

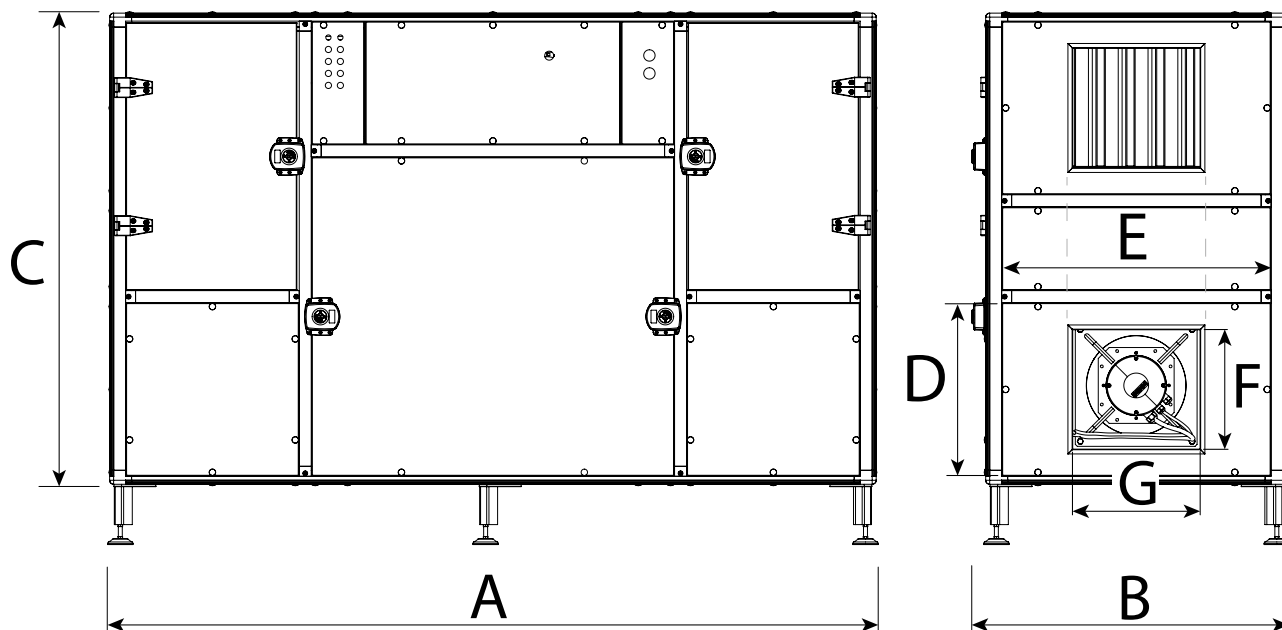

Model	A (mm)	B (mm)	C (mm)	D (mm)	E (mm)	F (mm)	G (mm)	WEIGHTS	
								with packaging	without packaging
ENY-PV2	1920	790	1180	433	673	300	320	245	220
ENY-PV3	2110	1110	1380	443	993	330	450	330	300
ENY-PV4	2300	1310	1480	443	1193	330	650	432	400
ENY-PV5	2300	1310	1750	578	1193	465	850	507	475

### » UNIT DIMENSIONS WITH PACKAGING

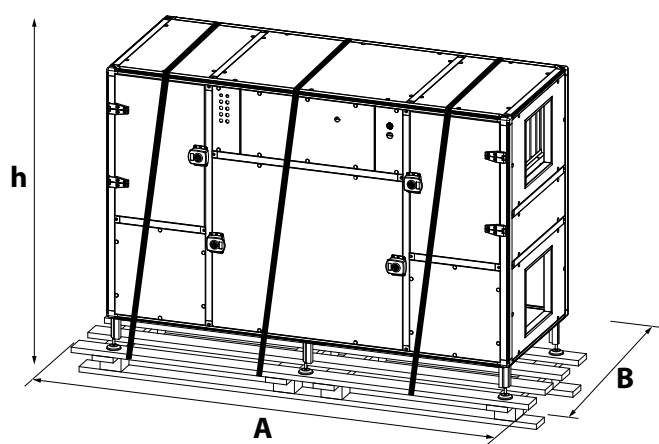

**NOTE:** To establish the unit height, please note that it is equipped with special feet for its positioning on the ground.

The feet can be adjusted from a minimum of 150 mm to a maximum of 200 mm.

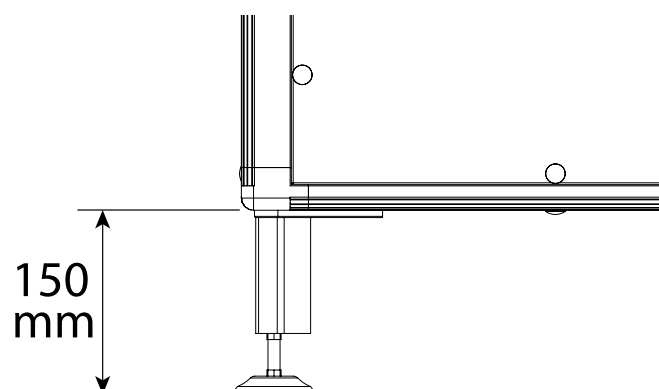

Model	A (mm)	B (mm)	h (mm)
ENY-PV2	2200	815	1470
ENY-PV3	2360	1135	1670
ENY-PV4	2550	1340	1770
ENY-PV5	2550	1340	2040

**POSITION OF THE CONDENSATE DRAIN**

The following table lists the positioning heights relating to the condensate drain from the tray.

The positioning of the condensate drain in left-side version machines refers to height A. For right-side version machines, the position of the tray is specular and, therefore, refers to height B.

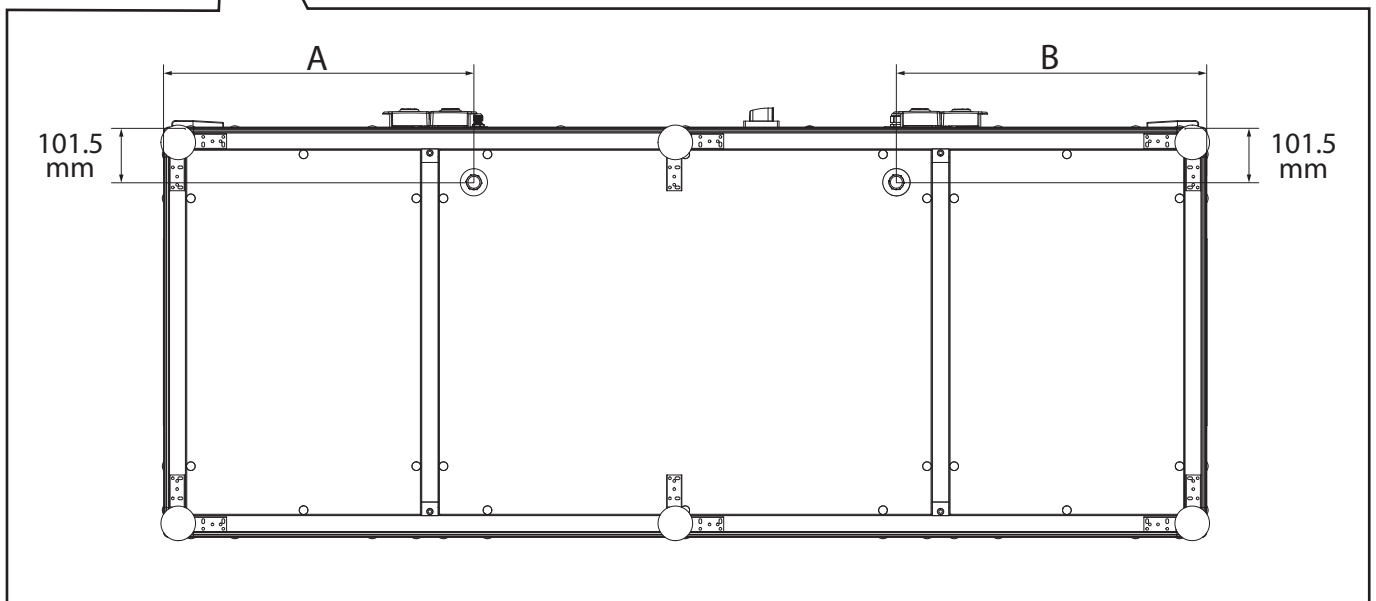
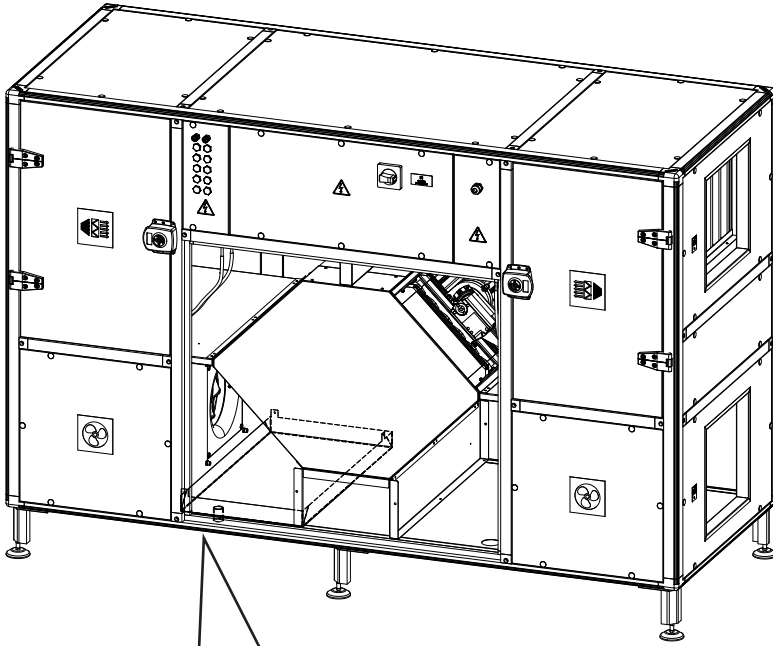

<b><i>Model</i></b>	<b>A and B (mm)</b>
<b>ENY-PV2</b>	571
<b>ENY-PV3</b>	581
<b>ENY-PV4</b>	581
<b>ENY-PV5</b>	581.5

## GENERAL DESCRIPTION OF UNIT OPERATION

The ENY-PV units are designed to exchange the room air in commercial, office and residential applications.

According to current regulations, the air exchange in buildings must be provided with the aim of maintaining hygienic conditions in spaces occupied by people and, at the same time, avoid the deterioration of the internal building structures.

The reference standards for calculating the necessary air changes are UNI10339, UNI 13779 and UNI 15251.

Furthermore, it is always necessary to consult the local Regulations that eventually establish specific requirements.

The ENY-PV units have important flexibility of use and ease of installation:

- The “vertical” structure with overlapping sections minimises the footprint occupied by the unit.
- Installation is easy by placing the feet on the floor.
- The units can be ordered with the external connections on the left (STANDARD) or on the right (INVERSE).
- It is possible to reconfigure some units in order to provide lateral (from the sides) or upper (from above) connections.
- The units have a smooth and clean external shape, without external electrical boxes which would risk being hit or damaged during handling.
- All components subject to maintenance can be inspected from the front.
- The filter compartment can be inspected through doors with hinges and handle with lock.

In order to limit the opening dimensions, the exchanger compartment inspection can be removed without rotating the door.

For easy and comfortable removal in case of replacement, the heat exchangers and filters are divided into modules.

The ENY-PV units make it possible to exchange the air and at the same time provide additional important services such as:

- Recover over 85% of ventilation heat thanks to the use of counter flow aluminium heat exchangers.
- The filtration of fresh air thanks to the use of standard supplied filters that allow the removal of up to 55% of up to 1 µm fine particles.

The maintenance of maximum filtering efficiency is ensured by the indication of the need for replacement, subject to monitoring of the actual level of obstruction of the filters.

- Certain flow rate thanks to the constant flow rate control system.

- Variable flow rate operation is possible in response to the modulation of external adjustment systems, thanks to the constant differential pressure control system.

- By selecting the integrated units with internal electric preheating heater, the risk of the exchanger freezing is drastically reduced.

- Possibility of integrating the ventilation unit with external hydronic post-treatment sections to maintain the neutral air temperature.

The installation of the ENY-PV units helps to make a responsible choice in saving energy, thanks to the following features:

- Compliance with the 2018 requirements of EU Regulation 1253/14 regarding internal pressure drops.
- Use of brushless electronic synchronous fans with backward curved blades.
- Use of high-efficiency and low pressure drop heat exchangers.
- Integration of the by-pass section with modulating damper capable of splitting or completely excluding the summer free-cooling exchanger.
- Integration of advanced logics to limit exchanger freezing in the absence of pre-heating and without sacrificing room comfort.

An additional element of quality and safety is established with the electrical panel placed within the perimeter of the units and that can be inspected by accessing the related front panel.

The solution provides a high protection rating of the internal electronics, a clean and tidy layout of the electrical distributions and an adequate level of electrical safety thanks to the presence of circuit breakers, before each inspection, make it possible to interrupt power to the main circuits from the outside.

The ENY-PV units are standard equipped with a wired wall control, equipped with a backlit display. The command is the basic interface for setting the ventilation mode and for displaying the alarm states.

## TECHNICAL DATA

	Unit of measurement	Model			
		ENY-PV2	ENY-PV3	ENY-PV4	ENY-PV5
Nominal flow rate	m <sup>3</sup> /h	1100	2000	3000	3850
Nominal available static pressure	Pa	500	500	500	600
Yield EN308	%	84.4%	84.2%	84%	83%
Electric power supply	-	230Vac 50Hz	400Vac 50Hz (3P+N)		
Maximum absorbed power (fans and controllers)	kW	1.2	1.7	2.6	3.8
Maximum current output (fans and controllers)	A	5	3	4.5	6
Protection Fuses	A	6	4	8	8
Models with heater					
Internal electric heater power	kW	4	8	11	13
Maximum current output with heater	A	17.5	11.5	16	18.8
Protection Fuses Electric heater	A	20	16	20	25
Filtering efficiency	-	<b>F7</b> ---- Fine Efficiency Filter: EN 779 F7-ISO 16890 ePM 1 55% <b>M6</b> ---- Average Efficiency Filter M6: EN 779 M6-ISO 16890 ePM 10 55%			

### Sound power data radiated from the casing

	Unit of measurement	Model			
		ENY-PV2	ENY-PV3	ENY-PV4	ENY-PV5
Sound power radiated from the Casing LWA	dB <sub>A</sub>	71.3	70.7	73.8	77.8

### Sound power data transmitted by the air flows at the nominal operating point

	Unit of measurement	Model			
		ENY-PV2	ENY-PV3	ENY-PV4	ENY-PV5
Intake/exhaust flow	dB <sub>A</sub>	82.3	81.7	84.8	88.4
Fresh air intake/extraction flow	dB <sub>A</sub>	76.3	75.7	78.8	82.4

## LEFT-SIDE CONFIGURATION UNIT - Unit with constant flow rate (ENY-PVx QL) -

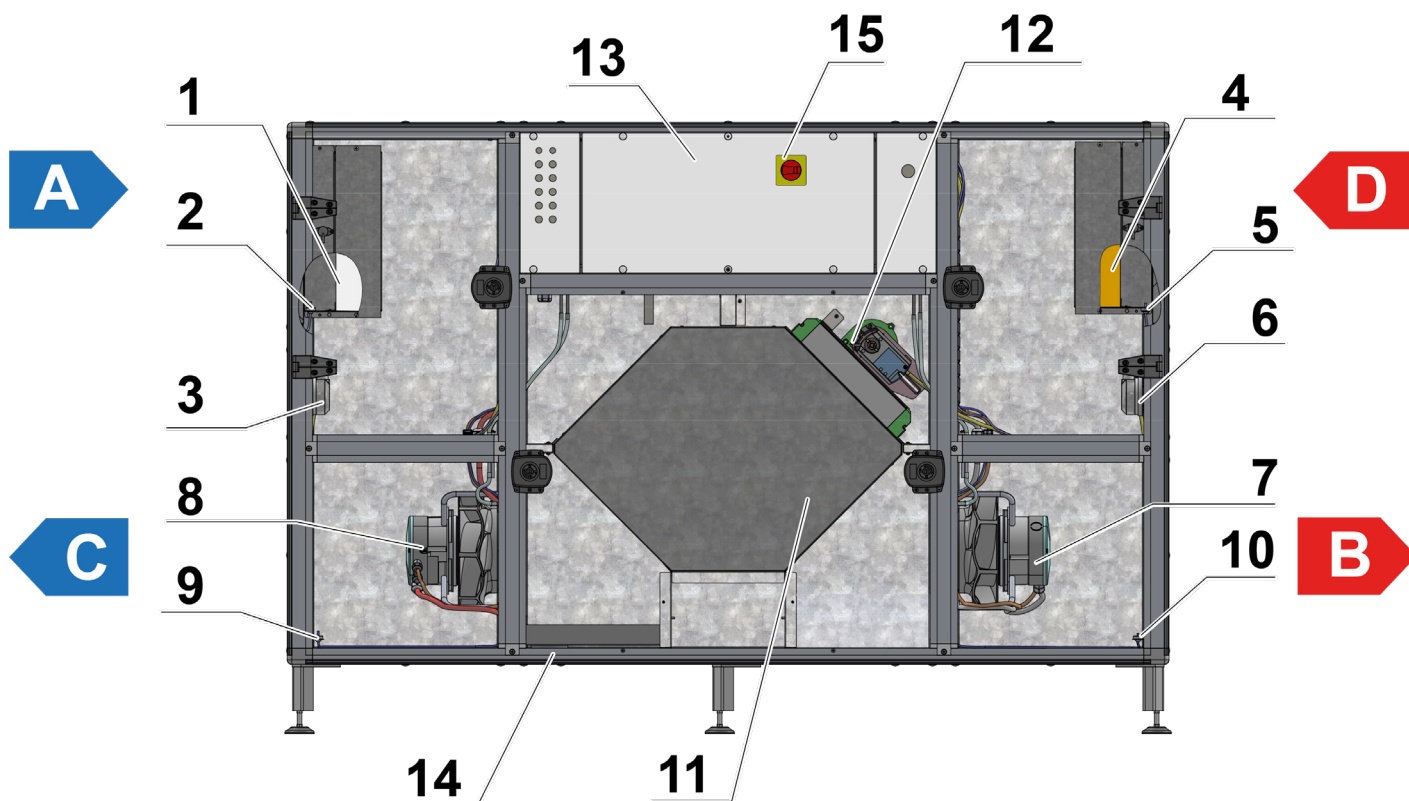

- |   |   |
|---|---|
| <ol style="list-style-type: none"> <li>1. Efficiency filter F7 (FINE FILTRATION)</li> <li>2. Fresh air temperature probe (T1)</li> <li>3. Differential pressure switch on F7 filter</li> <li>4. Efficiency filter M6 (AVERAGE FILTRATION)</li> <li>5. Extracted stale air temperature probe (T3)</li> <li>6. Differential pressure switch on M6 filter</li> <li>7. Supply air fan</li> <li>8. Stale air extraction fan</li> </ol> | <ol style="list-style-type: none"> <li>9. Exhaust air temperature probe (T4)</li> <li>10. Supply air temperature probe (T2)</li> <li>11. Heat exchanger</li> <li>12. Bypass Damper System</li> <li>13. Electrical panel</li> <li>14. Condensate drain</li> <li>15. Electrical part rotary disconnecting switch</li> </ol> |
|---|---|

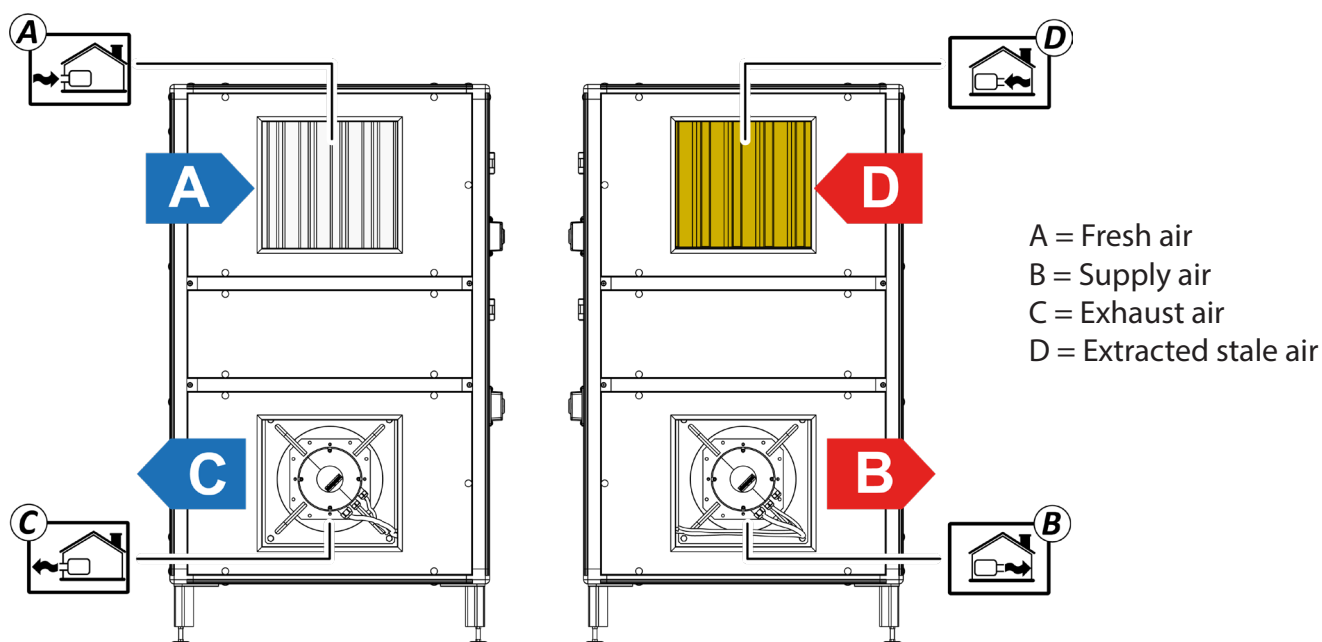

## RIGHT-SIDE CONFIGURATION UNIT - Unit with constant flow rate (ENY-PVx QR) -

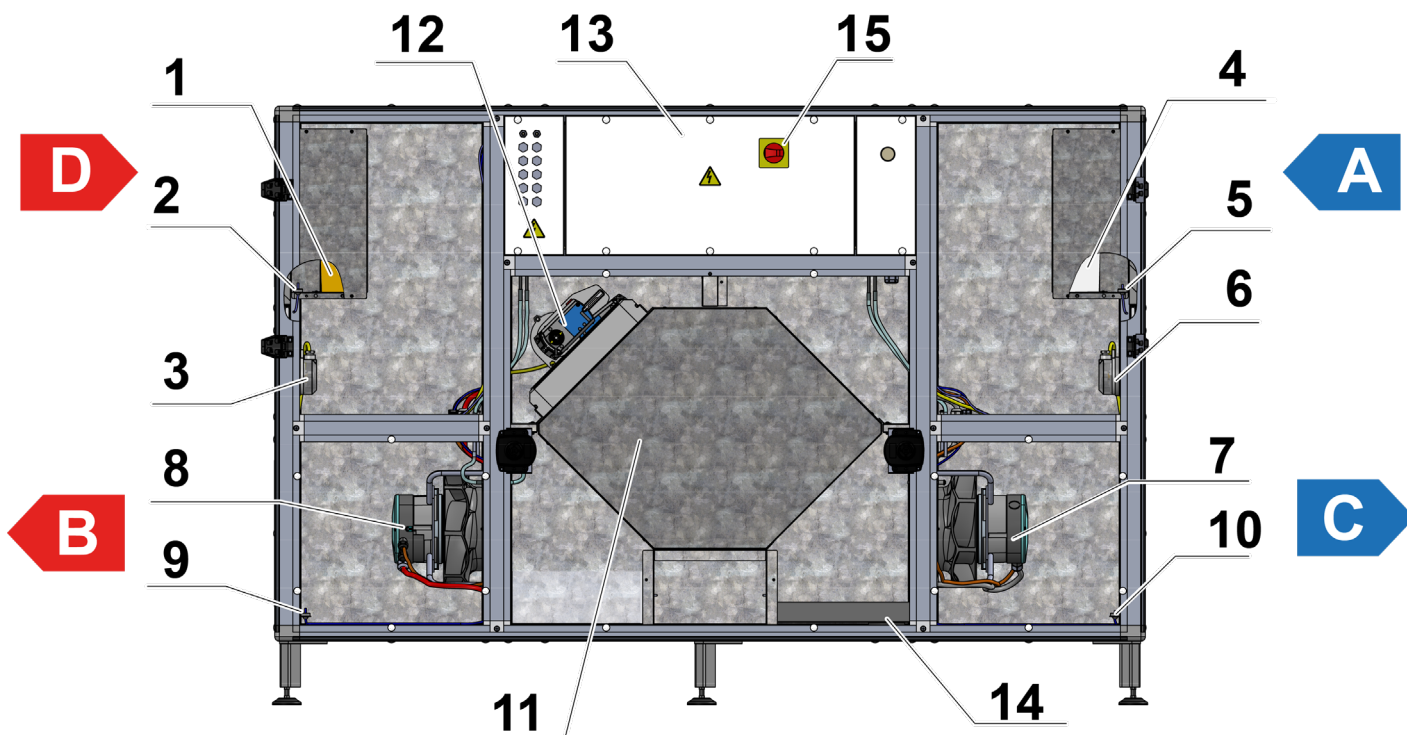

- |   |   |
|---|---|
| <ol style="list-style-type: none"> <li>1. Efficiency filter M6 (AVERAGE FILTRATION)</li> <li>2. Extracted stale air temperature probe (T3)</li> <li>3. Differential pressure switch on M6 filter</li> <li>4. Efficiency filter F7 (FINE FILTRATION)</li> <li>5. Fresh air temperature probe (T1)</li> <li>6. Differential pressure switch on F7 filter</li> <li>7. Stale air extraction fan</li> <li>8. Supply air fan</li> </ol> | <ol style="list-style-type: none"> <li>9. Supply air temperature probe (T2)</li> <li>10. Exhaust air temperature probe (T4)</li> <li>11. Heat exchanger</li> <li>12. Bypass Damper System</li> <li>13. Electrical panel</li> <li>14. Condensate drain</li> <li>15. Electrical part rotary disconnecting switch</li> </ol> |
|---|---|

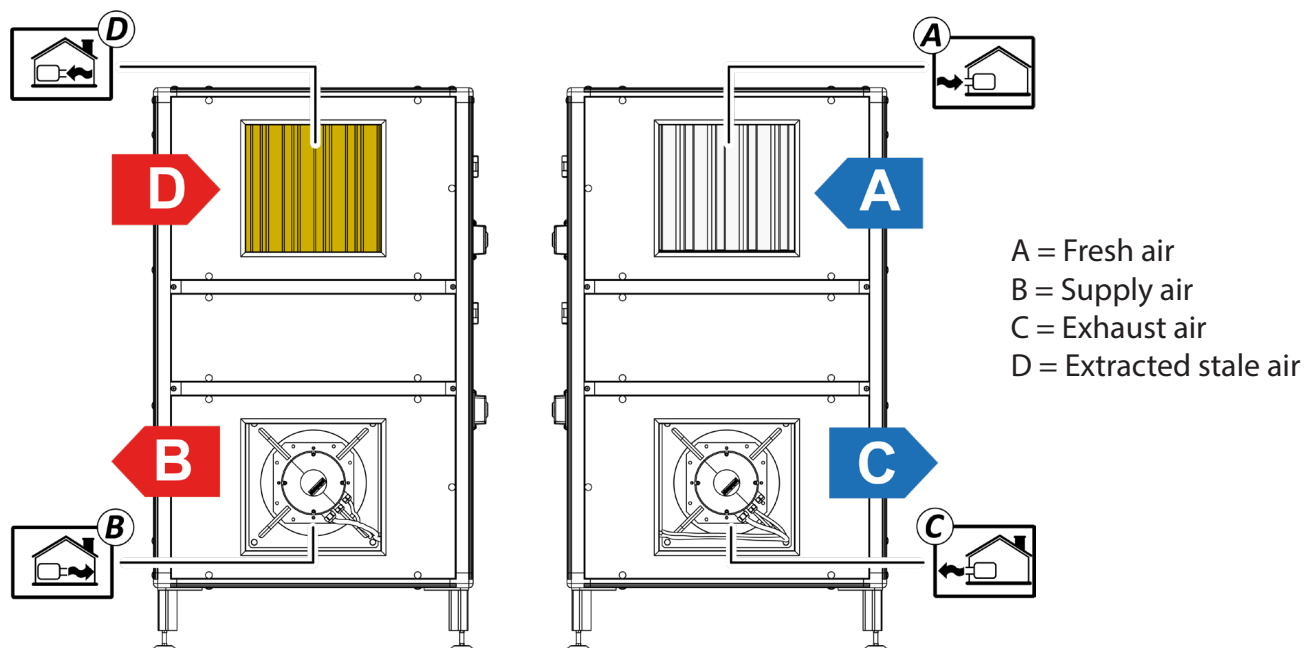

## LEFT-SIDE CONFIGURATION UNIT

### - Constant differential pressure unit (ENY-PVx DPL) -

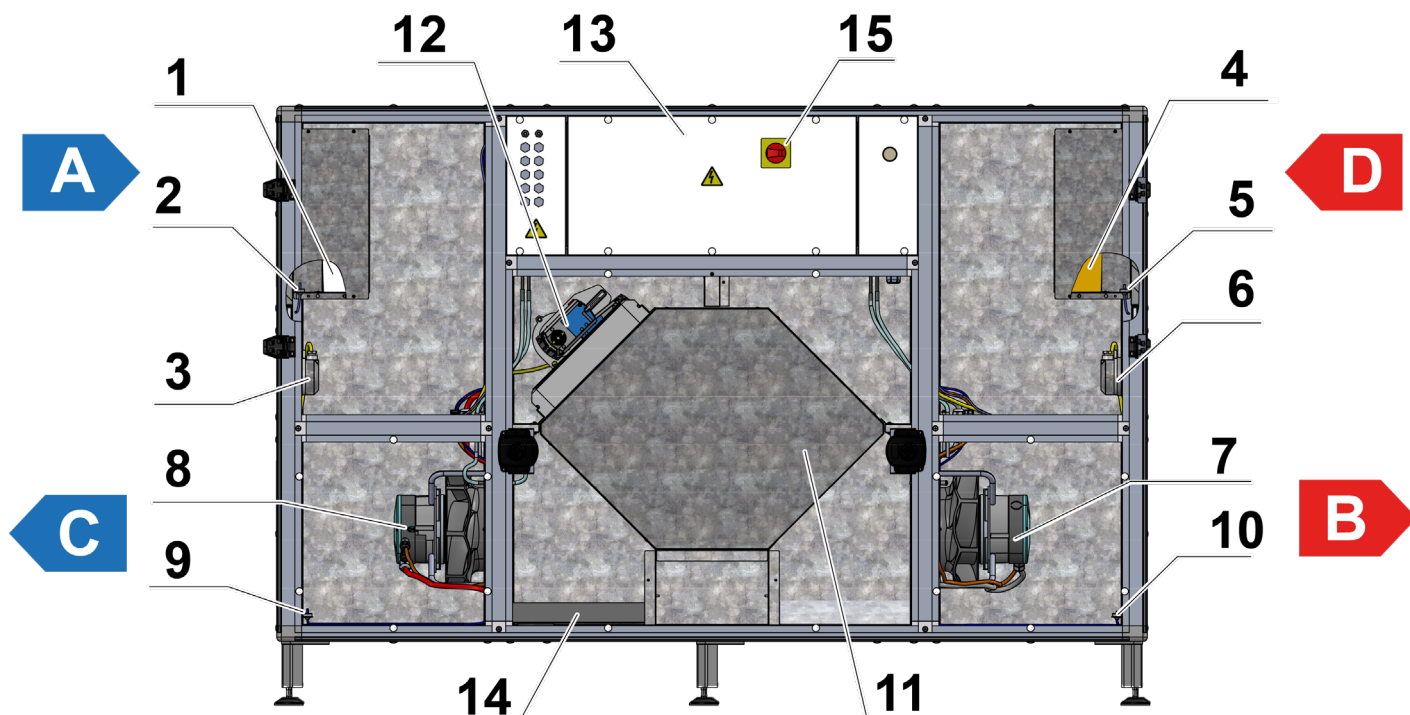

- |   |   |
|---|---|
| 1. Efficiency filter M6 (AVERAGE FILTRATION)  | 9. Supply air temperature probe (T2)            |
| 2. Extracted stale air temperature probe (T3) | 10. Exhaust air temperature probe (T4)          |
| 3. Differential pressure switch on M6 filter  | 11. Heat exchanger                              |
| 4. Efficiency filter F7 (FINE FILTRATION)     | 12. Bypass Damper System                        |
| 5. Fresh air temperature probe (T1)           | 13. Electrical panel                            |
| 6. Differential pressure switch on F7 filter  | 14. Condensate drain                            |
| 7. Stale air extraction fan                   | 15. Electrical part rotary disconnecting switch |
| 8. Supply air fan                             |   |

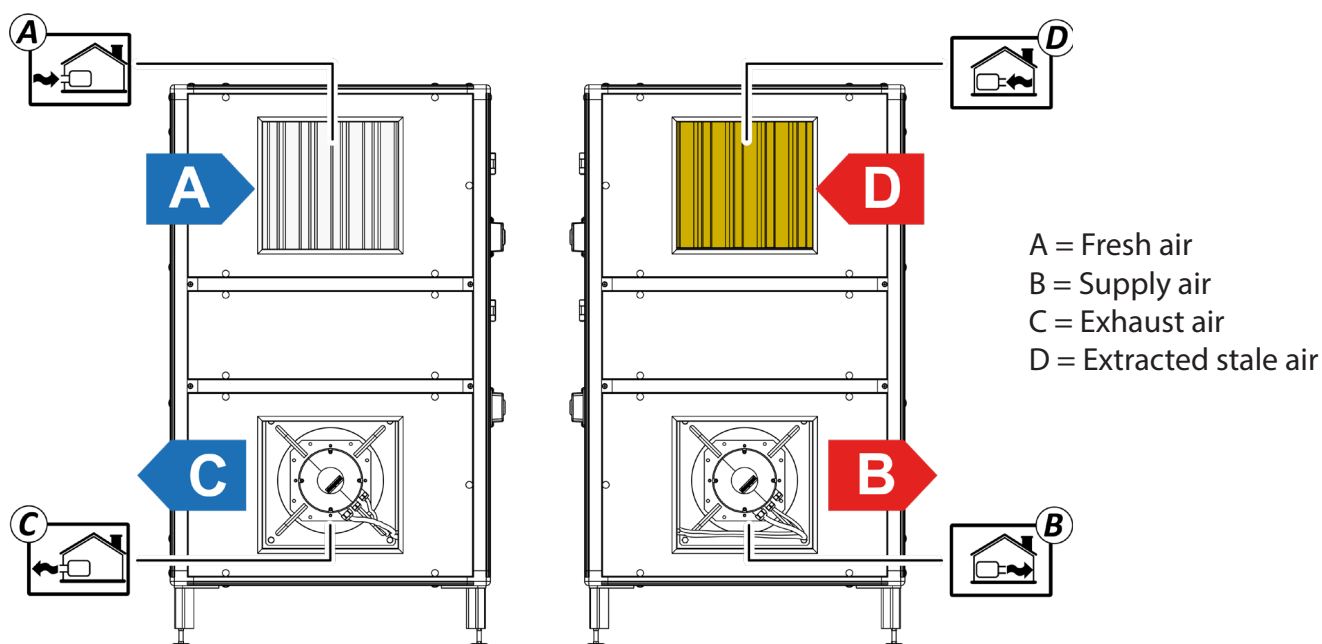

## RIGHT-SIDE CONFIGURATION UNIT - Constant differential pressure unit (ENY-PVx DPR) -

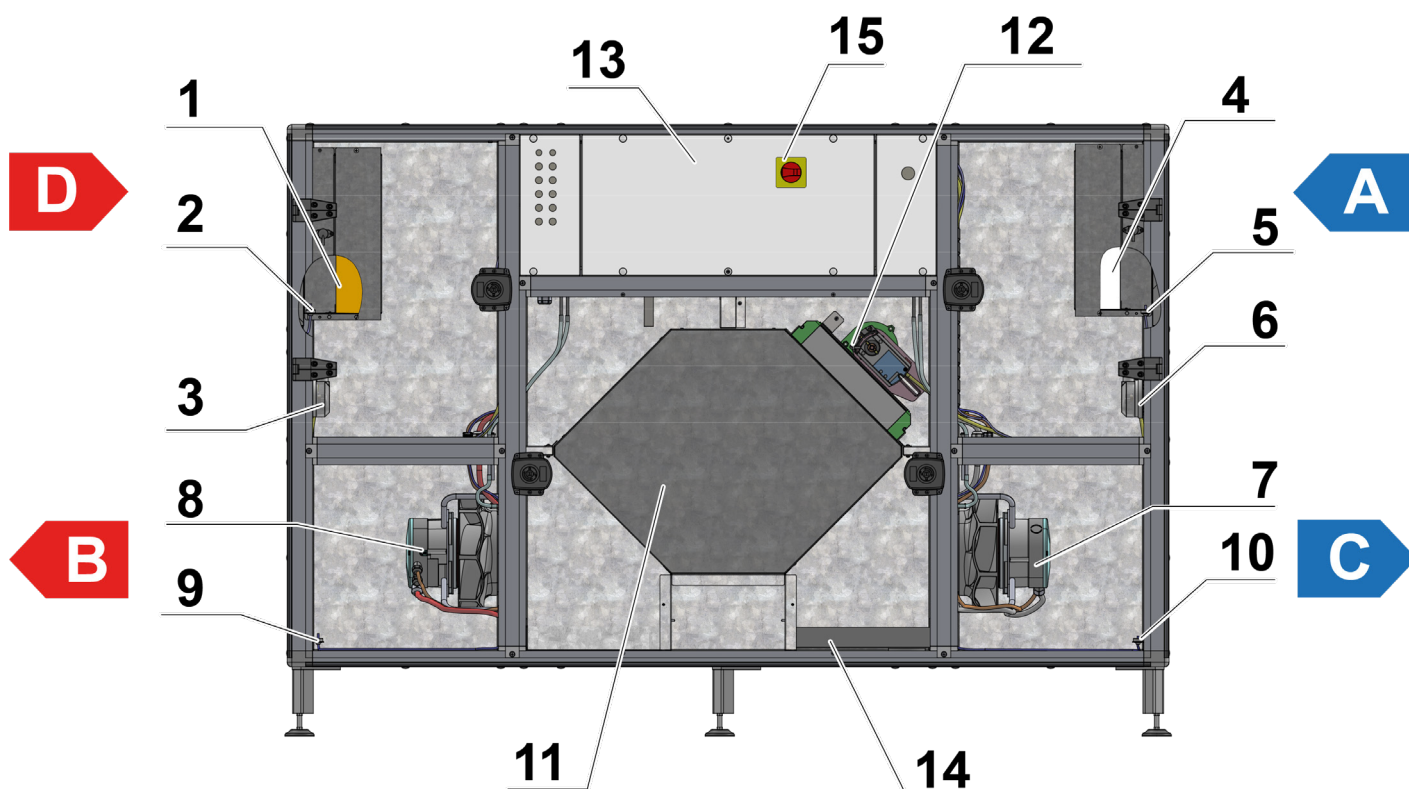

- |   |   |
|---|---|
| <ol style="list-style-type: none"> <li>1. Efficiency filter M6 (AVERAGE FILTRATION)</li> <li>2. Extracted stale air temperature probe (T3)</li> <li>3. Differential pressure switch on M6 filter</li> <li>4. Efficiency filter F7 (FINE FILTRATION)</li> <li>5. Fresh air temperature probe (T1)</li> <li>6. Differential pressure switch on F7 filter</li> <li>7. Stale air extraction fan</li> <li>8. Supply air fan</li> </ol> | <ol style="list-style-type: none"> <li>9. Supply air temperature probe (T2)</li> <li>10. Exhaust air temperature probe (T4)</li> <li>11. Heat exchanger</li> <li>12. Bypass Damper System</li> <li>13. Electrical panel</li> <li>14. Condensate drain</li> <li>15. Electrical part rotary disconnecting switch</li> </ol> |
|---|---|

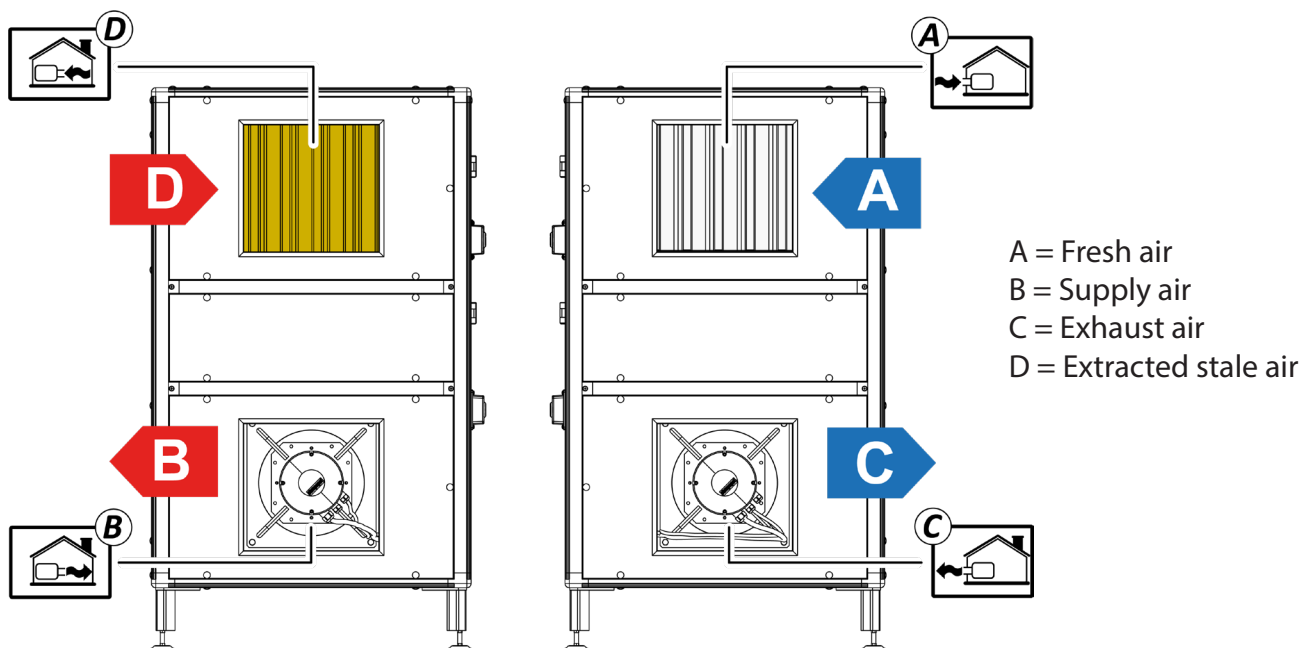

## LEFT-SIDE CONFIGURATION UNIT WITH ELECTRIC HEATER

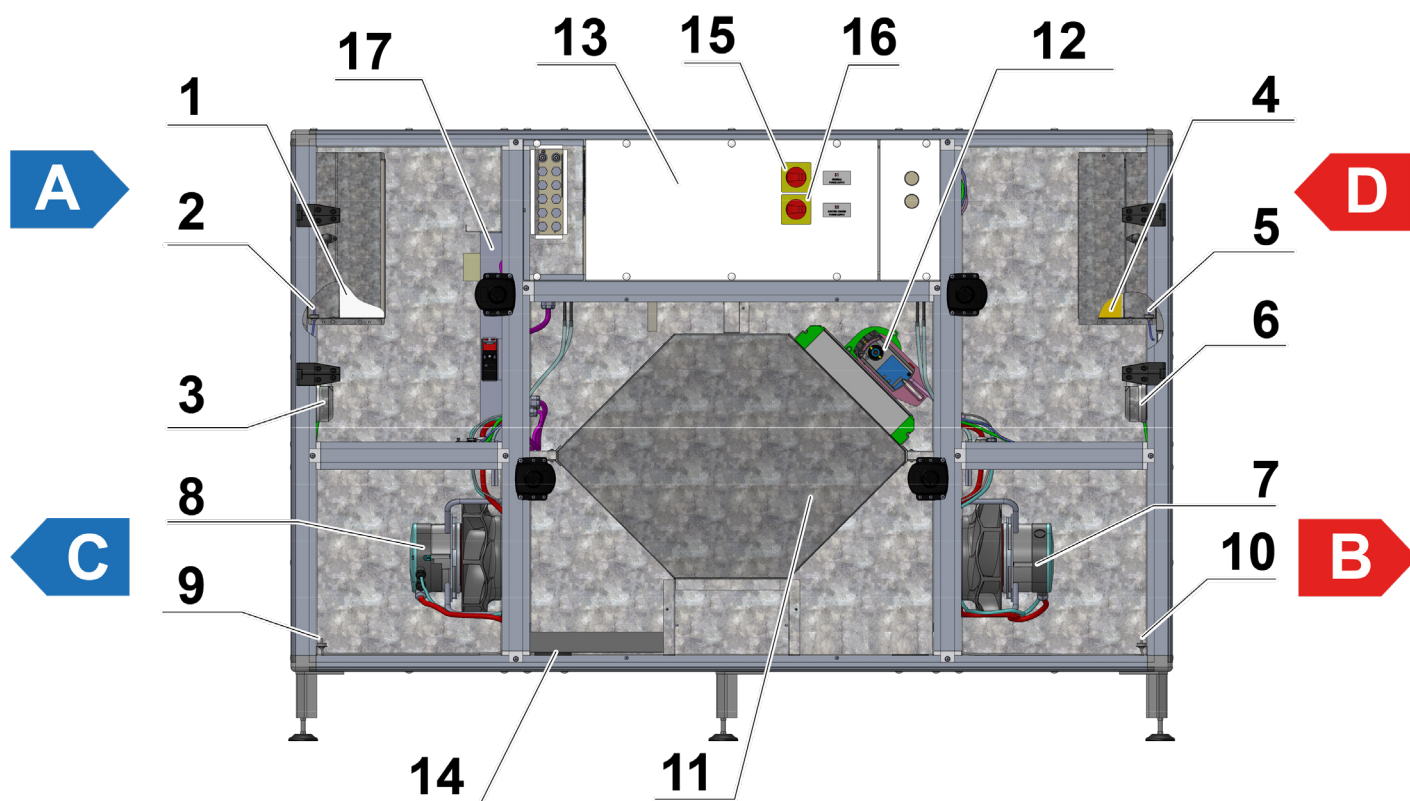

- |   |   |
|---|---|
| 1. Efficiency filter F7 (FINE FILTRATION)     | 10. Supply air temperature probe (T2)                                   |
| 2. Fresh air temperature probe (T1)           | 11. Heat exchanger  |
| 3. Differential pressure switch on F7 filter  | 12. Bypass Damper System  |
| 4. Efficiency filter M6 (AVERAGE FILTRATION)  | 13. Electrical panel  |
| 5. Extracted stale air temperature probe (T3) | 14. Condensate drain  |
| 6. Differential pressure switch on M6 filter  | 15. Electrical part rotary disconnecting switch                         |
| 7. Supply air fan                             | 16. AC1 load power supply rotary disconnecting switch - electric heater |
| 8. Stale air extraction fan                   | 17. Electric heater   |
| 9. Exhaust air temperature probe (T4)         |   |

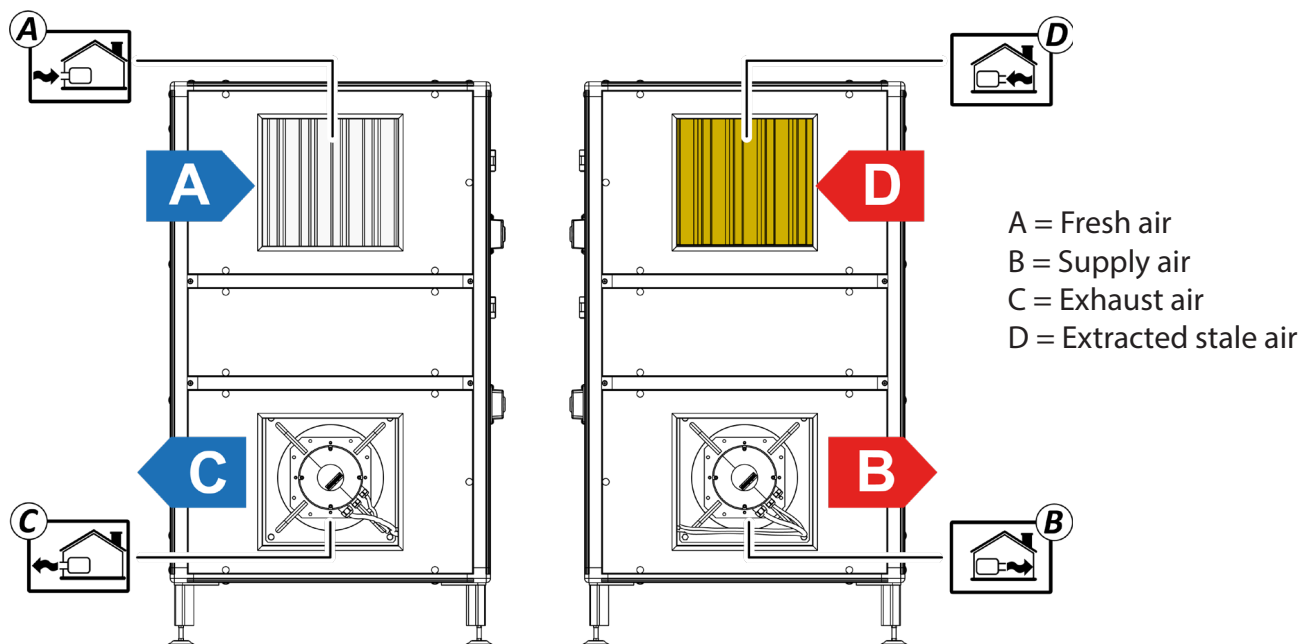

## RIGHT-SIDE CONFIGURATION UNIT WITH ELECTRIC HEATER

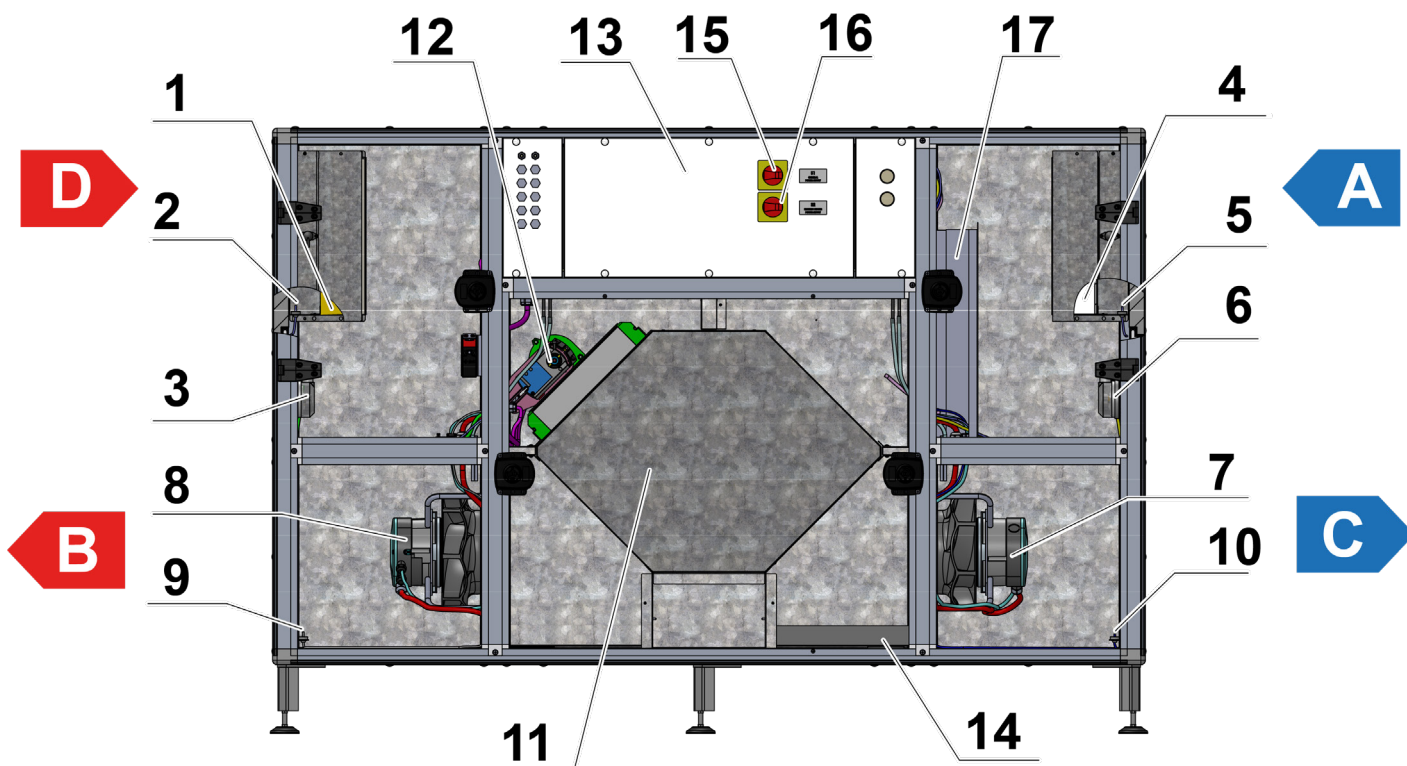

- |   |   |
|---|---|
| 1. Efficiency filter M6 (AVERAGE FILTRATION)  | 10. Exhaust air temperature probe (T4)                                  |
| 2. Extracted stale air temperature probe (T3) | 11. Heat exchanger  |
| 3. Differential pressure switch on M6 filter  | 12. Bypass Damper System  |
| 4. Efficiency filter F7 (FINE FILTRATION)     | 13. Electrical panel  |
| 5. Fresh air temperature probe (T1)           | 14. Condensate drain  |
| 6. Differential pressure switch on F7 filter  | 15. Electrical part rotary disconnecting switch                         |
| 7. Stale air extraction fan                   | 16. AC1 load power supply rotary disconnecting switch - electric heater |
| 8. Supply air fan                             | 17. Electric heater   |
| 9. Supply air temperature probe (T2)          |   |

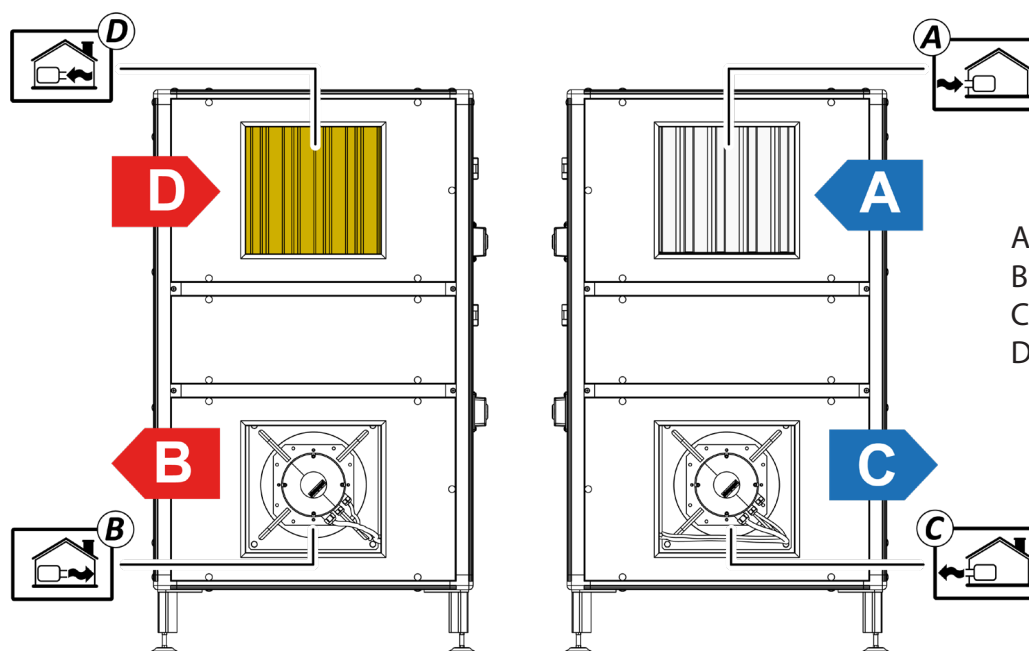

- A = Fresh air  
 B = Supply air  
 C = Exhaust air  
 D = Extracted stale air

# INSTALLATION



## » INSTALLATION CONDITIONS

The machine must only be installed by qualified and properly trained staff.

Do not leave the unit exposed to atmospheric agents. Use the unit only for the use for which it was expressly built. The manufacturer cannot be held responsible for any damage caused by improper or incorrect use.

It is recommended to install the unit inside buildings with a temperature between 0° and +50°C, avoiding areas near sources of heat, steam, gas or flammable and/or explosive liquids, particularly dusty areas, near water sources such as tubs, showers or pools.

Consider a position that does not obstruct passages or entrances;

The assembly location must be level and able to withstand the weight of the ventilation unit for a long time and not transmit vibrations during operation (see weight table).

Consider an area where the noise due to the unit casing and the air flows do not cause disturbance;

Consider a position that has the minimum spaces to be observed for installation and maintenance access (Fig.1);

The unit must be installed in a frost-free room.

The room must have a connection for the water drain, and for draining any condensate that may form.

## » INSTALLATION MODE (Fig. 1)

The unit is equipped with special feet for horizontal positioning on the floor.

Level the unit using the feet: turning the bolt in the mounting feet raises or lowers the corner of the unit.

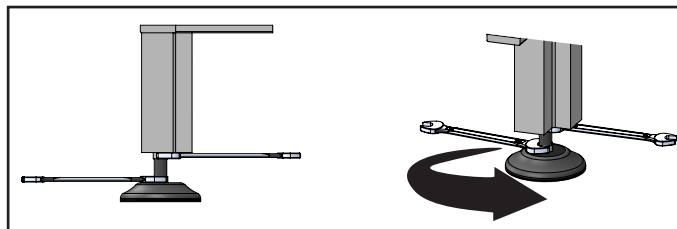

In this way, the unit can be adjusted to be made horizontal.

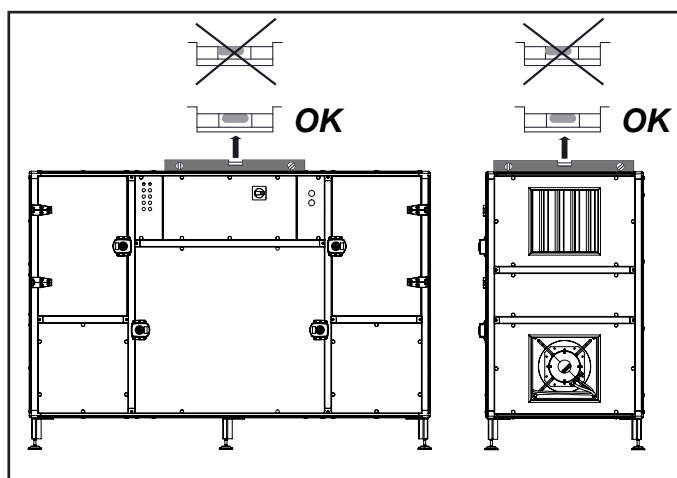

When the unit is in place, there must be enough space around it to ensure proper operation and maintenance.

Fig.1 and the table indicate the minimum spaces recommended.

Once the unit has been placed in the right position, make the connection with the ductwork, fasten the condensate drain pipe on the air exhaust side and connect the electrical panel to the mains.

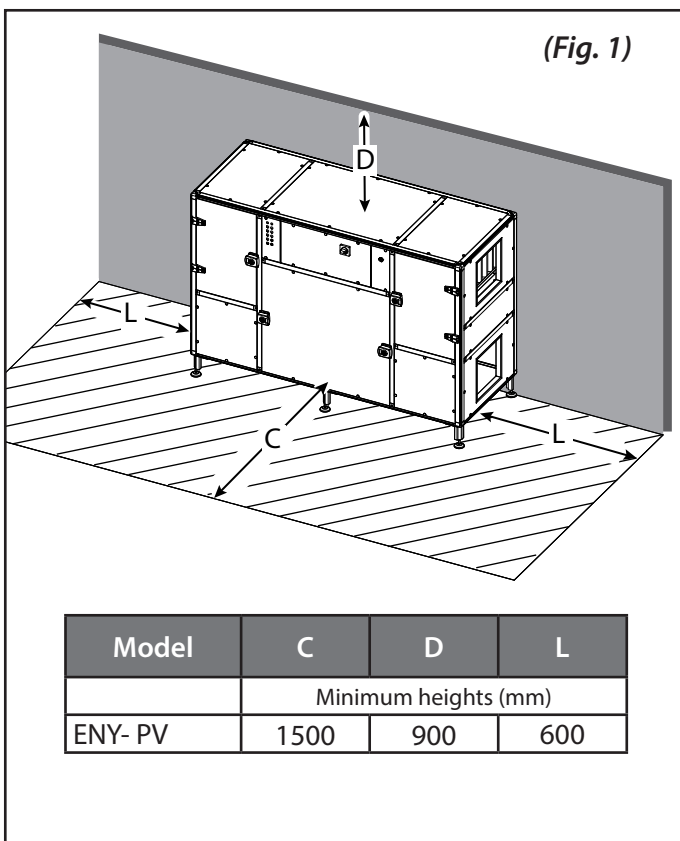

» **CONDENSATE DRAIN ASSEMBLY (Fig. 2)**

The unit is equipped with a drain for draining the water that forms during normal operation. The connection for the condensate drain is located underneath the unit.

A drain pipe with siphon and a minimum slope of 3% must always be provided in order to avoid the stagnation of condensate water.

The siphon is necessary for the outflow of condensate without air flow leaks through the drain pipes and also to ensure a hydraulic disjunction that prevents odours from rising from the sewer system.

The siphon must be correctly sized to avoid the suction of the hydraulic disjunction stagnation due to the strong negative pressure condition that can occur in the collection tray compartment.

The siphon must be filled with water and cautiously sized as follows for Negative pressure systems:

$$H1 = 2P$$

$$H2 = H1 / 2$$

P = max operating pressure of the heat recovery unit in mm, approx. (1 mm approx. = 9.81 Pa). --- P=100mm approx.

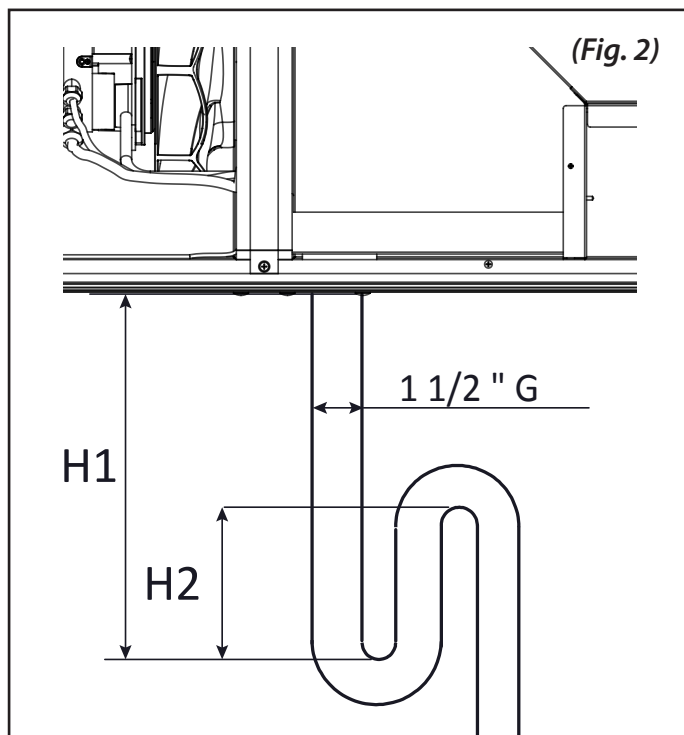

**DUCTWORK CONNECTIONS**

CAUTION! The units are set up as standard for connection to the rectangular section ducts.

**INSTALLATION EXAMPLE (LEFT-SIDE equipment version)**

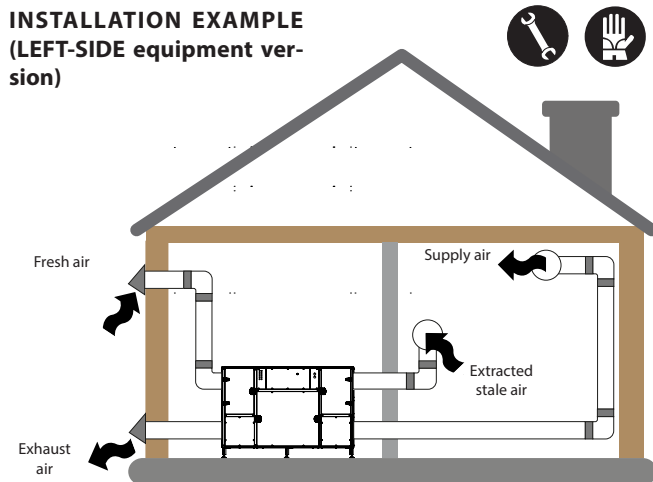

The connection ducts to the unit must be secured to the unit using a stop flange on the smooth surface of each of the 4 inlet panels.

To connect the ductwork, it is advisable to:

- ◇ clean the connection ends between the duct and the Unit;
- ◇ apply a gasket to the flanges of the ducts to avoid air infiltration;
- ◇ connect the duct to the unit, marking the duct holes on the structure and fixing with self-drilling screws.
- ◇ silicone the junction to optimise tightness.

**NOTE:** in order to ensure the tightness of the connections and the integrity of the unit structure, it is necessary to avoid the weight of the ductwork from weighing on it: the ductwork must be supported by special brackets or anchors (by the engineering fitter).

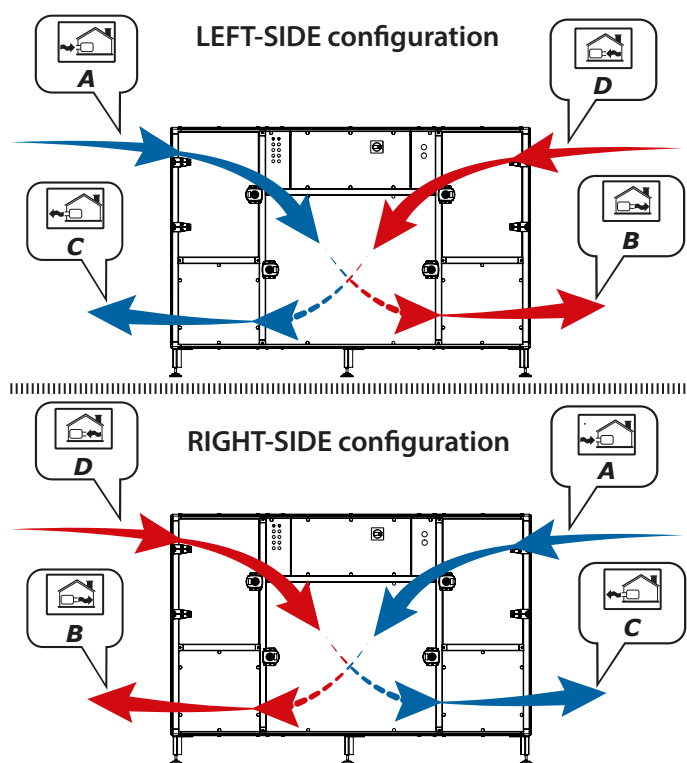

A = Fresh air    B = Supply air  
C = Exhaust air    D = Extracted stale air

## » DUCT CONNECTION FLEXIBILITY THROUGH LATERAL OR UPPER CONNECTION

The unit is factory supplied with lateral connections.

The connections can be moved from the side to the top, by performing simple operations.

**CAUTION!** The possibility of switching the connections on site is not available as standard for the ENY-PV5 unit.

1. Open the filter compartment door
2. Remove the fixing screws from the upper panel.

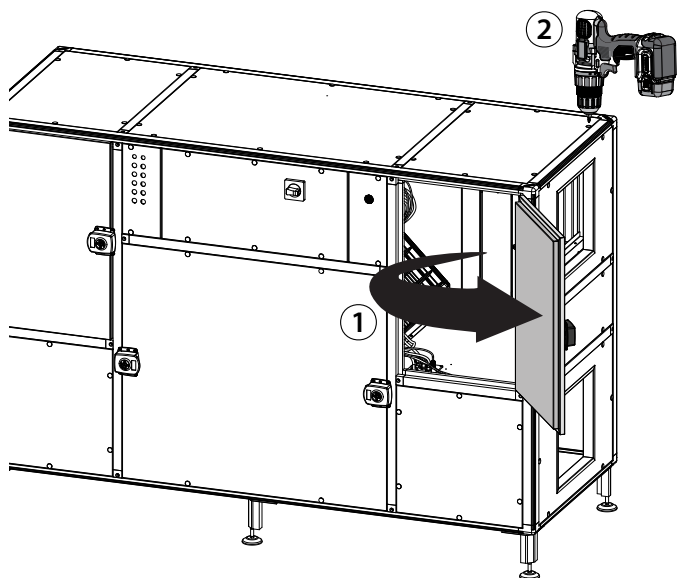

3. Remove the upper panel.

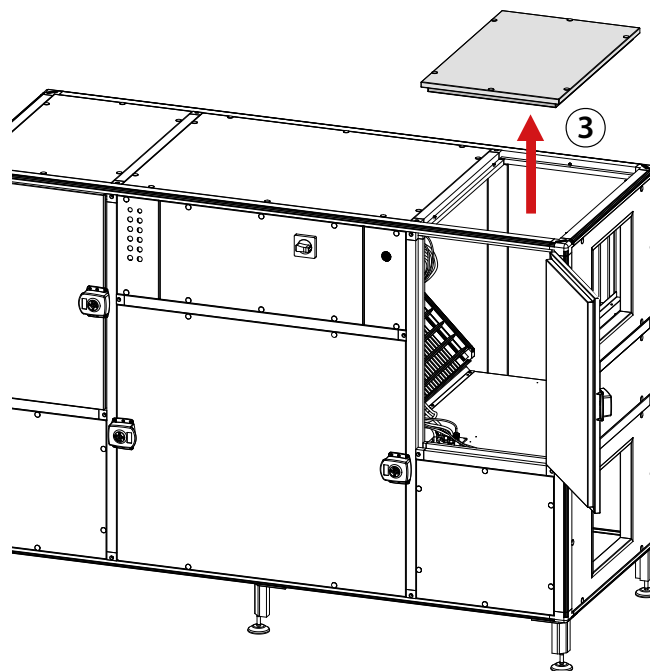

4. Remove the air temperature probe from its seat on the bottom of the filter.
5. Remove the connection pipe between the pressure outlet (on the filter) and the differential pressure switch.

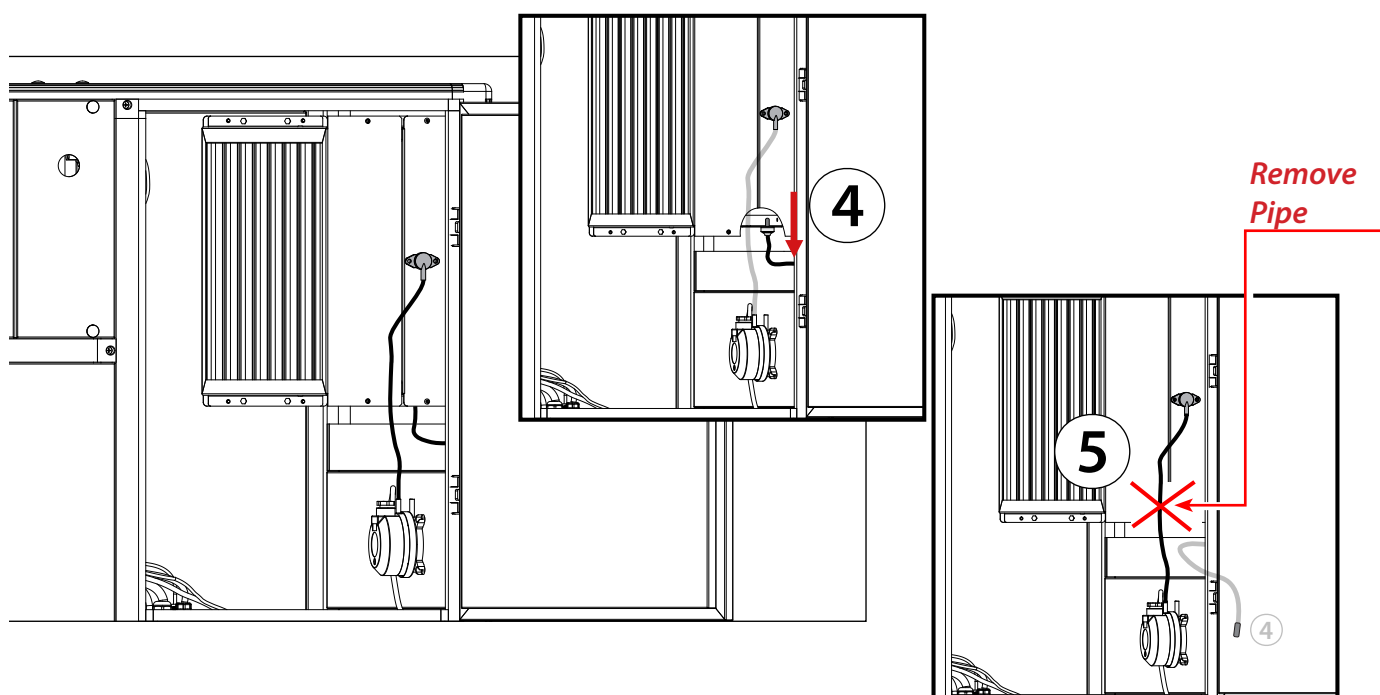

6. Remove the fixing screws from the side filter holder panel.
7. Remove the filter block.

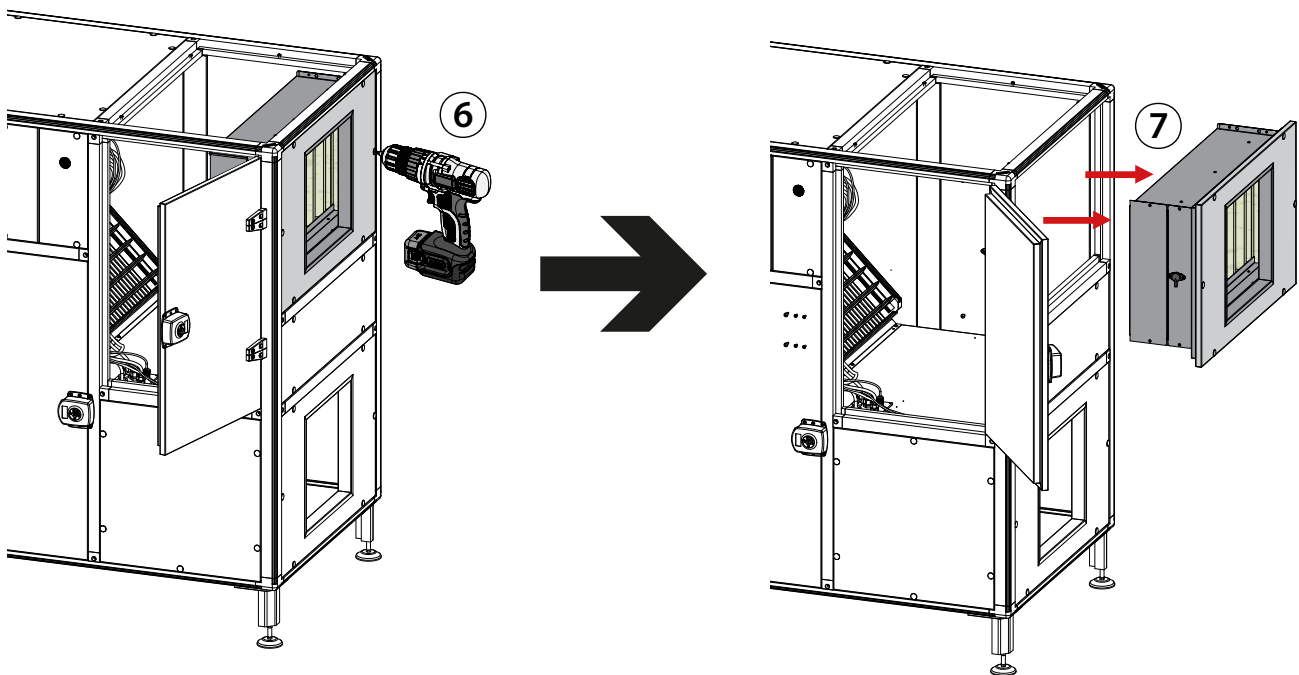

8. Rotate the filter block 90° (see image) so that the pressure outlet remains facing the outside of the machine.
9. Insert the filter block on the upper part of the machine.
10. Fix with the screws.

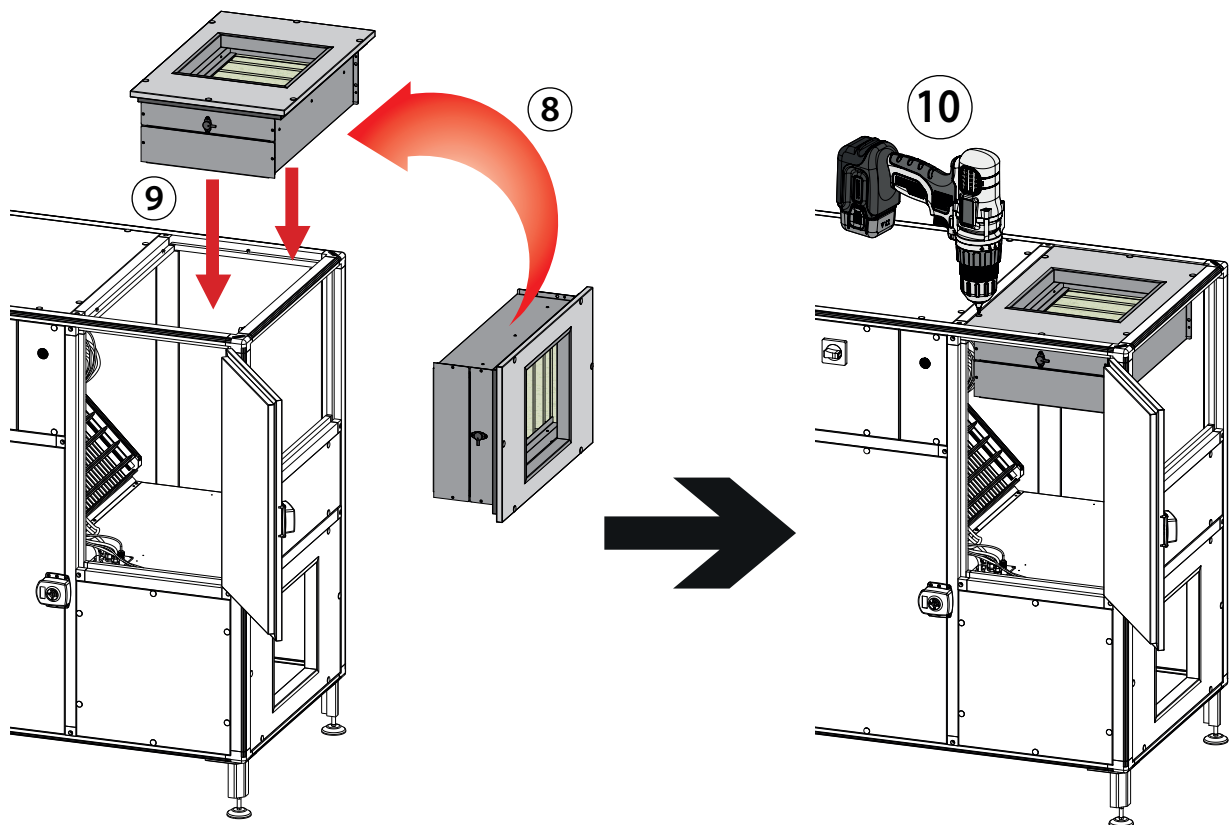

11. Insert the temperature probe in its seat again.
12. Make the connection again between the pressure outlet and the differential pressure switch.  
Use a silicone tube for the connection ( $\varnothing_i$  6 mm,  $\varnothing_e$  8 mm)

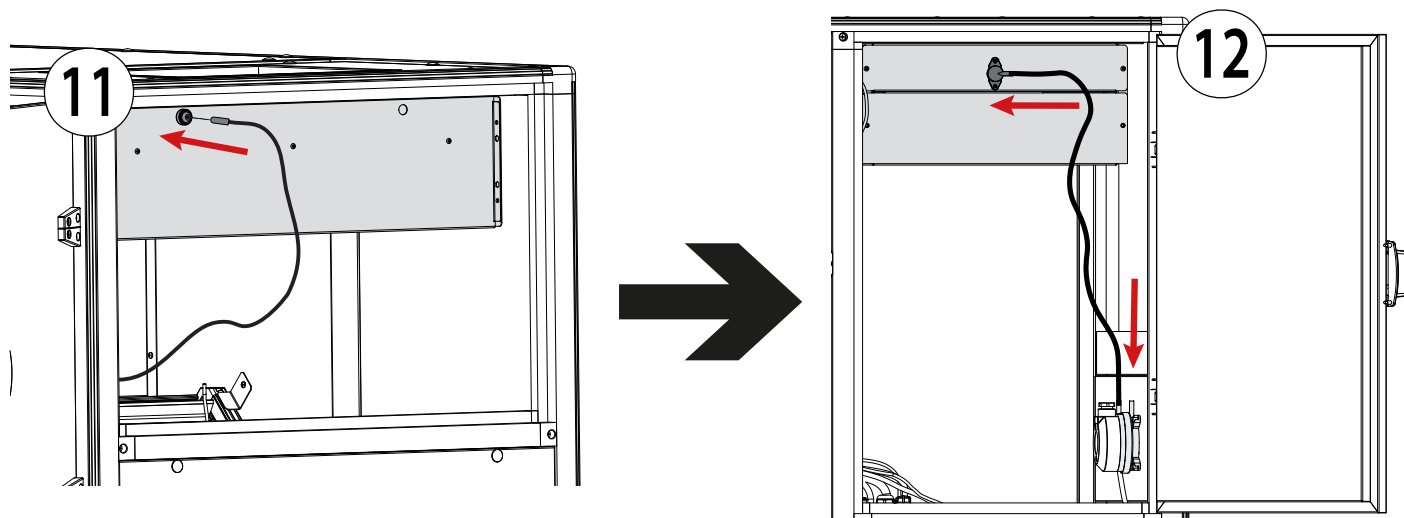

13. Take the panel previously removed from the top and place it on the side of the unit.
14. Fix the panel with the screws.

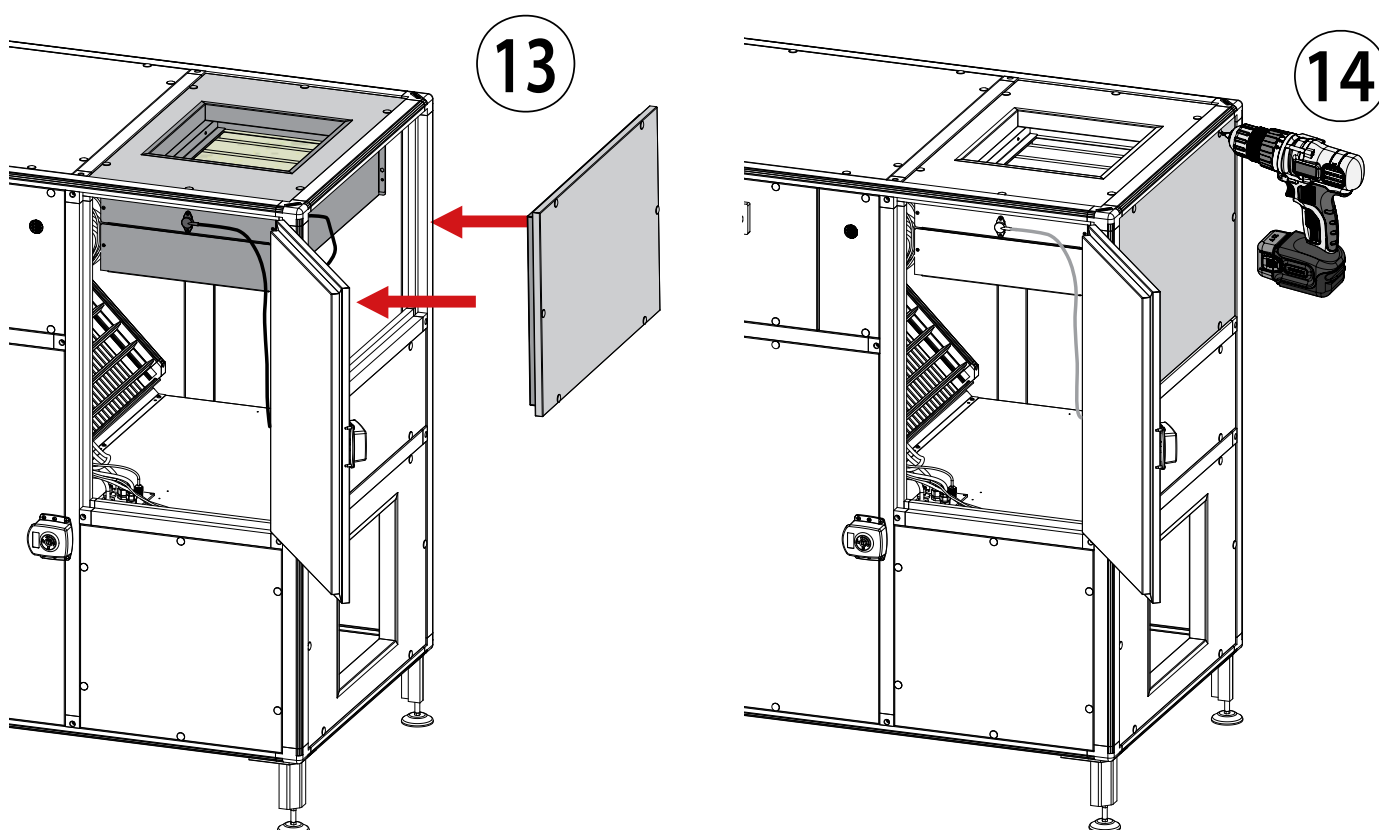

**NOTE:** The same operation can be performed for both sides or have a mixed configuration.



**IMPORTANT!:** once all the operations have been performed, close the inspection door.

## PERFORMANCE CURVES OF THE UNIT

The units can work freely within the action range recommended in the performance diagrams.

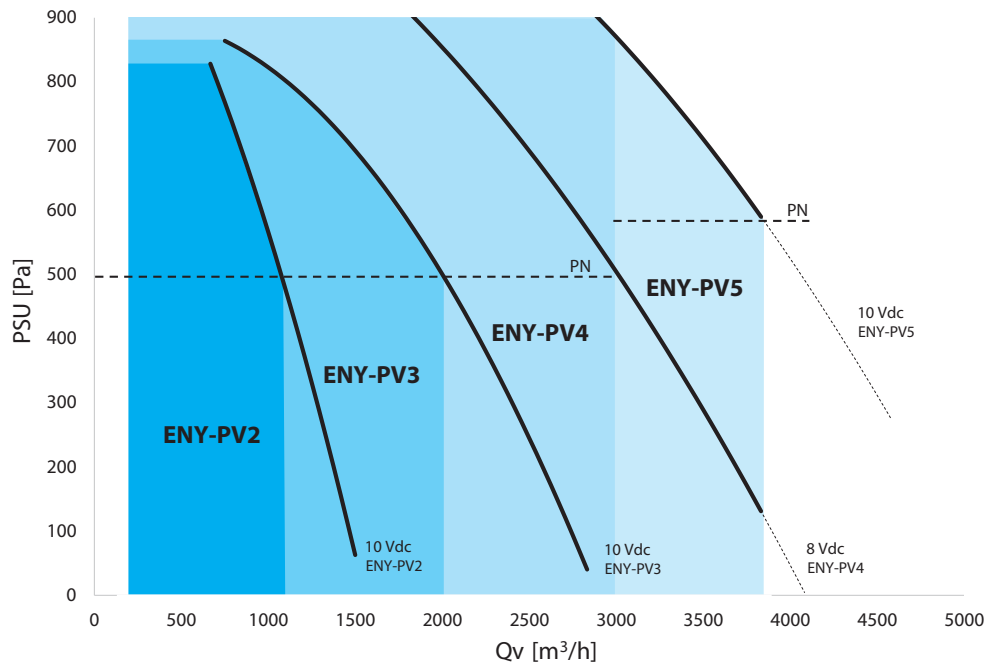

Psu = available static pressure

Qv = Air flow rate

PN = nominal available static pressure

Below are the recommended details for the operating range of the units:

Model	Nominal flow rate <sup>3</sup>	Nominal pressure <sup>4</sup>	Maximum pressure	Maximum flow rate at maximum pressure	Minimum flow rate recommended
	m <sup>3</sup> /h	Pa	Pa	m <sup>3</sup> /h	m <sup>3</sup> /h
ENY-PV2	1100	500	800	750	300
ENY-PV3	2000	500	850	800	500
ENY-PV4	3000	500	1000	2500	750
ENY-PV5	3850	600	1000	2600	1000

<sup>3</sup> The nominal flow rate corresponds to the maximum flow rate up to which it is possible to declare compliance of the internal pressure drops with EU Regulation 1253/14.

<sup>4</sup> The nominal pressure is the maximum head available at nominal flow rate.

## SFP<sub>int</sub> flow rate curve

Shown below is compliance with the EU Regulation 1253/14 for non-residential ventilation units, in relation to the maximum specific consumption required due to internal pressure drops  $SFP_{int}$ .

The ENY-PV units comply with the regulation up to operating flow rates corresponding to the nominal flow rate.

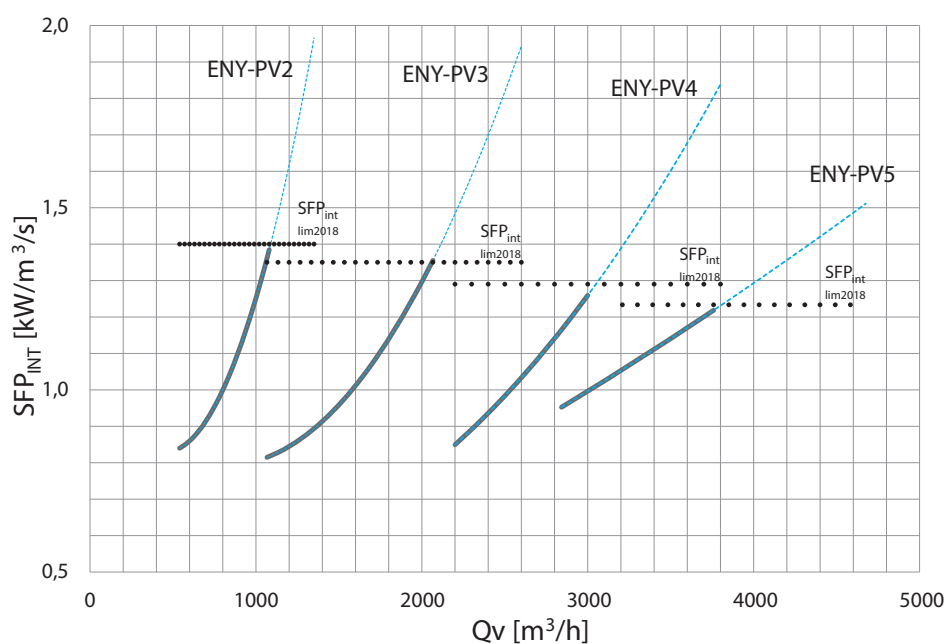

$Q_v$  = Air flow rate

## Thermal efficiency of exchangers according to EN 308 (25°C/5°C) dry conditions

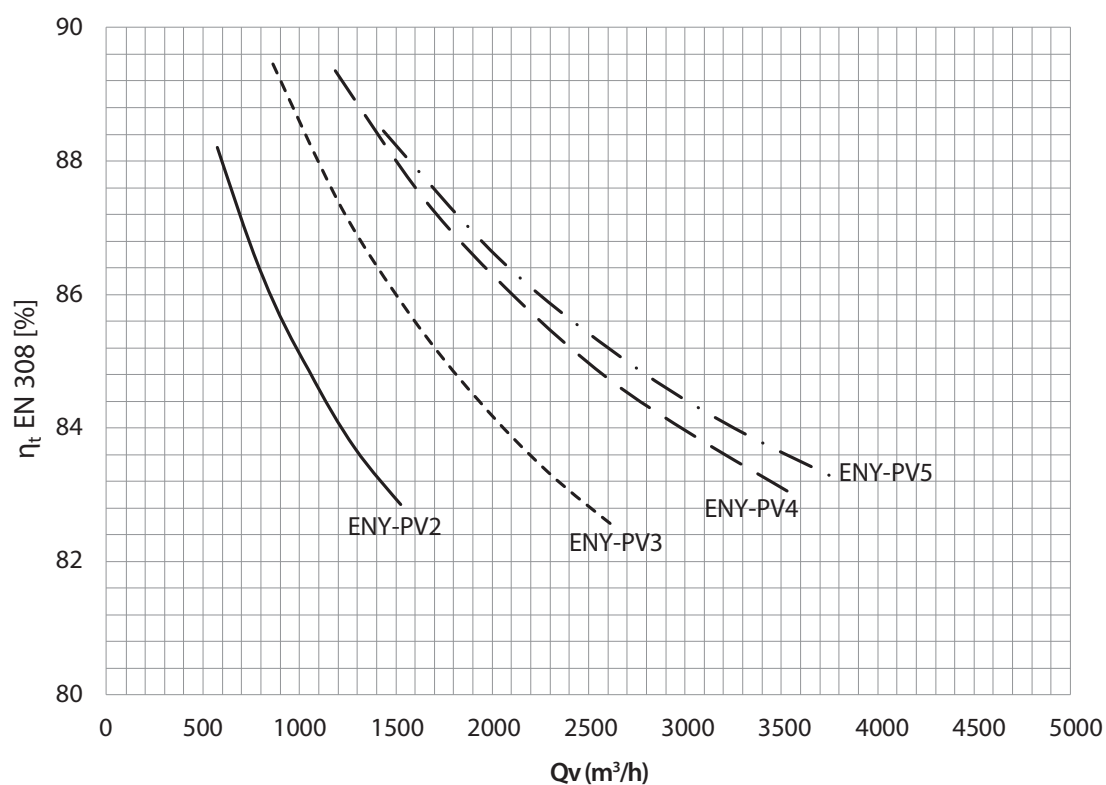

$\eta_t$  EN 308 = thermal efficiencies

$Q_v$  = Air flow rate

### Characteristic curves

The units are available factory supplied with the target flow rate or differential pressure control.

As an indication, the following diagrams show the available static flow rate/pressure curves of the machines at the different fan control voltages.

The performance can be used as reference both for the inlet flow with ePM<sub>1</sub> 55% filter and the extraction flow with ePM<sub>10</sub> 55% filter.

#### ENY-PV2

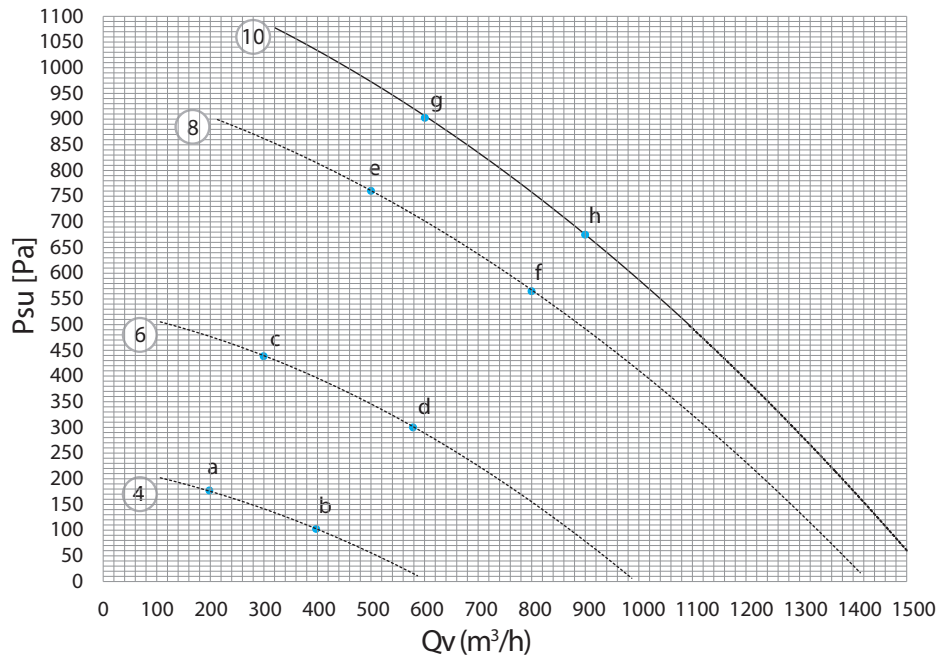

⊗ = control voltage  
 Psu = available static pressure  
 Qv = Air flow rate

ENY-PV2	a	b	c	d	e	f	g	h
Radiated Lw dB(A)	57.4	52.7	67.7	64.6	74.5	71.4	76.9	73.4
Supply Lw dB(A)	60.4	55.7	70.7	67.6	77.5	74.4	79.9	76.4
Extract Lw dB(A)	46.4	41.7	56.7	53.6	63.5	60.4	65.9	62.4

### Performance and absorption of the individual fan ENY-PV2

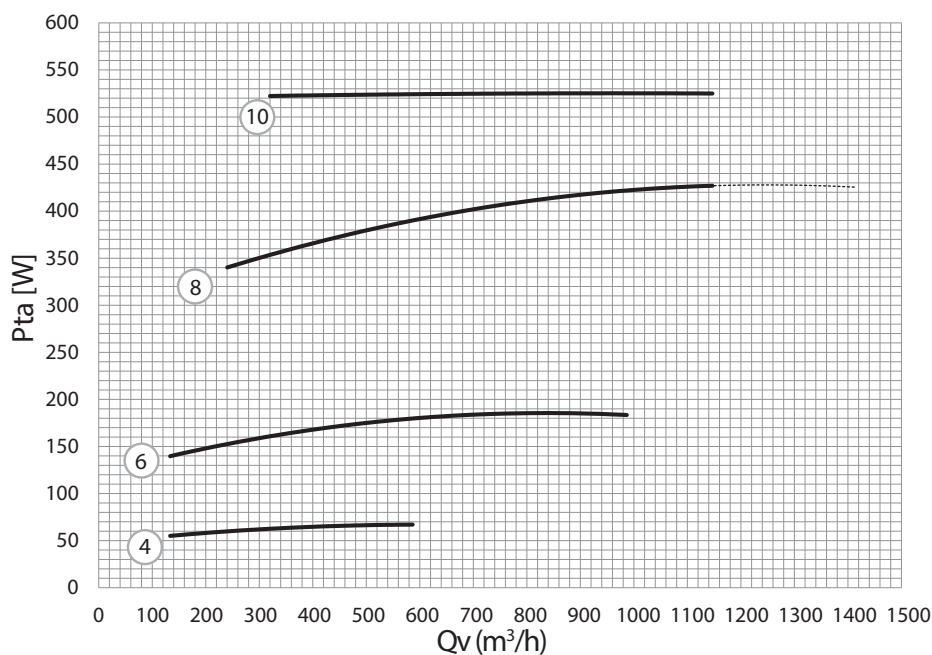

⊗ = control voltage  
 Pta = electrical power absorbed  
 Qv = Air flow rate

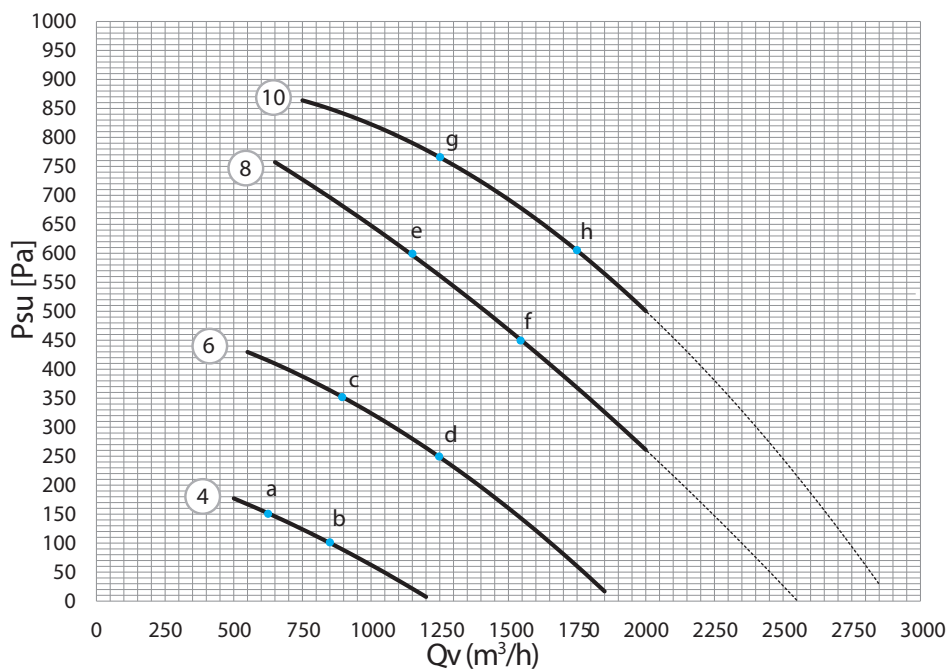
**ENY-PV3**

⊗ = control voltage  
 Psu = available static pressure  
 Qv = Air flow rate

ENY-PV3	a	b	c	d	e	f	g	h
Radiated Lw dB(A)	59.1	54.9	68.3	63.2	72.8	68.8	75.0	71.7
Supply Lw dB(A)	62.1	57.9	71.3	66.2	75.8	71.8	78.0	74.7
Extract Lw dB(A)	48.1	43.9	57.3	52.2	61.8	57.8	64.0	60.7

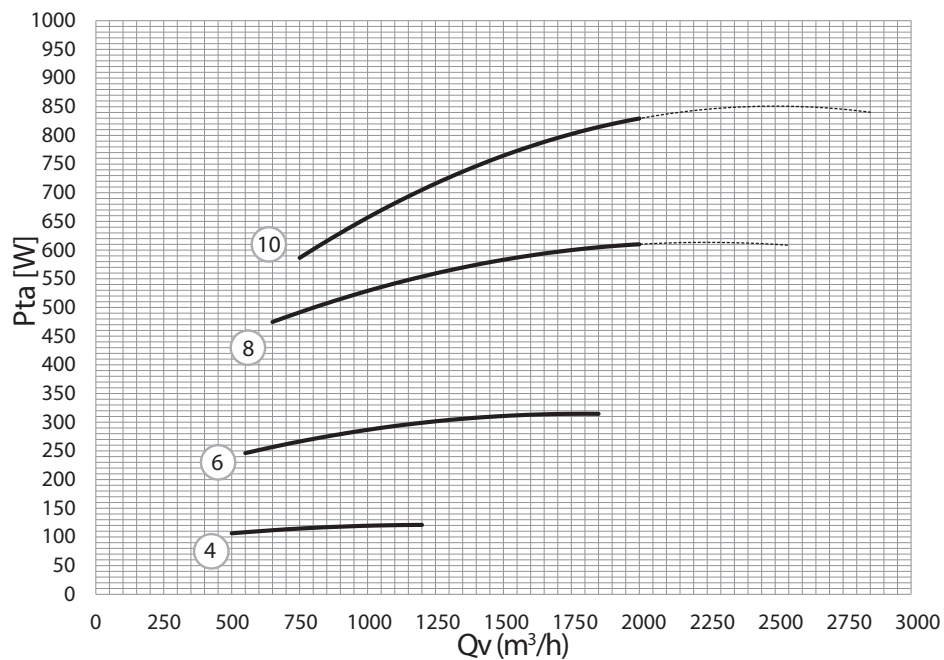
**Performance and absorption of the individual fan ENY-PV3**

⊗ = control voltage  
 Pta = electrical power absorbed  
 Qv = Air flow rate

**ENY-PV4**

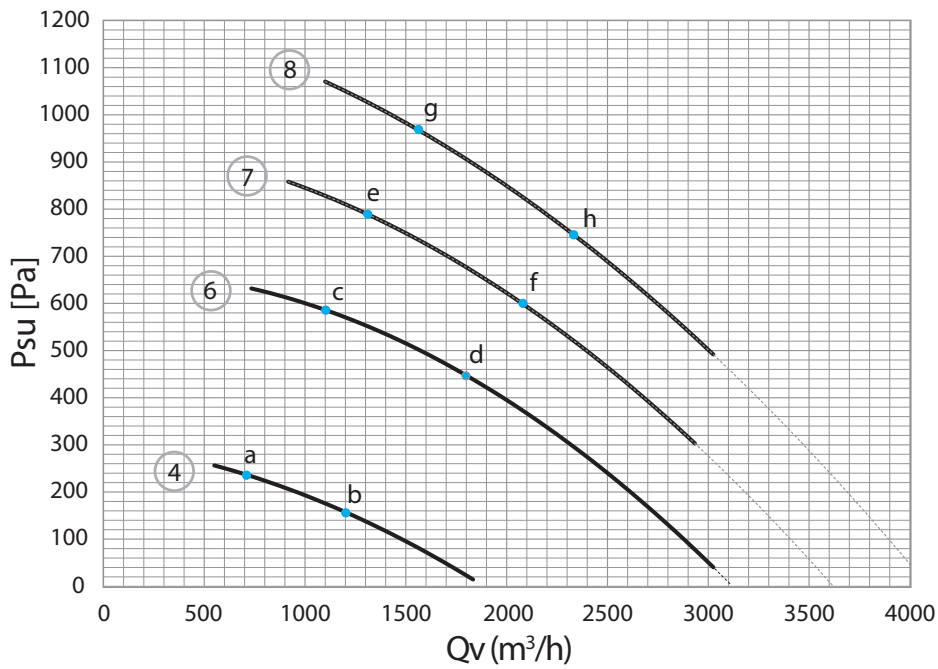

⊗ = control voltage  
 Psu = available static pressure  
 Qv = Air flow rate

ENY-PV4	a	b	c	d	e	f	g	h
Radiated Lw dB(A)	61.0	59.7	70.9	69.3	76.4	74.4	77.7	75.4
Supply Lw dB(A)	64.0	62.7	73.9	72.3	79.5	77.5	80.7	78.4
Extract Lw dB(A)	50.0	48.7	59.9	58.3	65.1	63.1	66.7	64.4

**Performance and absorption of the individual fan ENY-PV4**

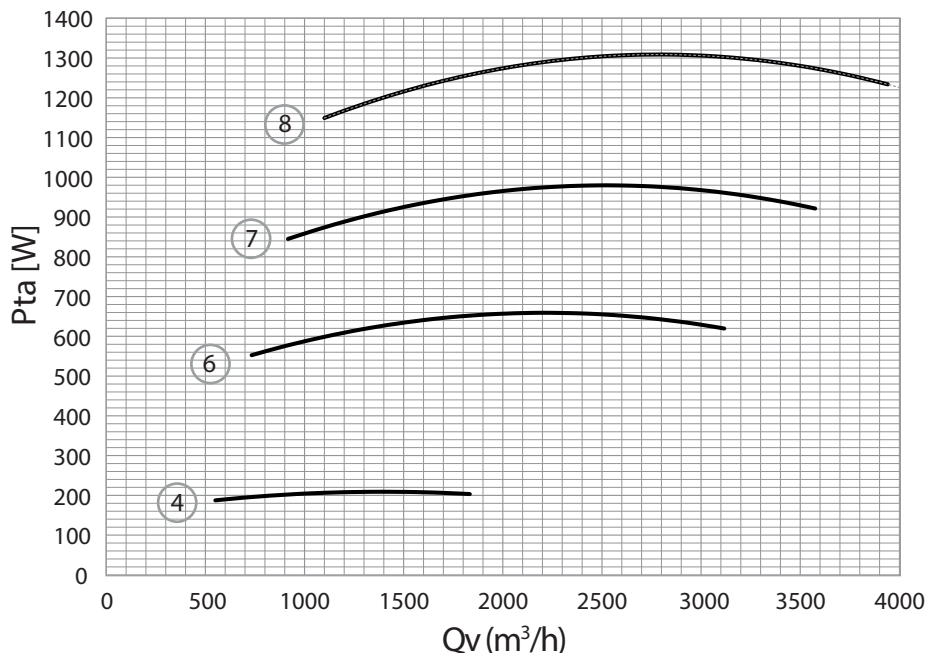

⊗ = control voltage  
 Pta = electrical power absorbed  
 Qv = Air flow rate  
 ENY-PV4 Reaches the nominal point of 3000 m³/h A 500 Pa at 8Vdc

## ENY-PV5

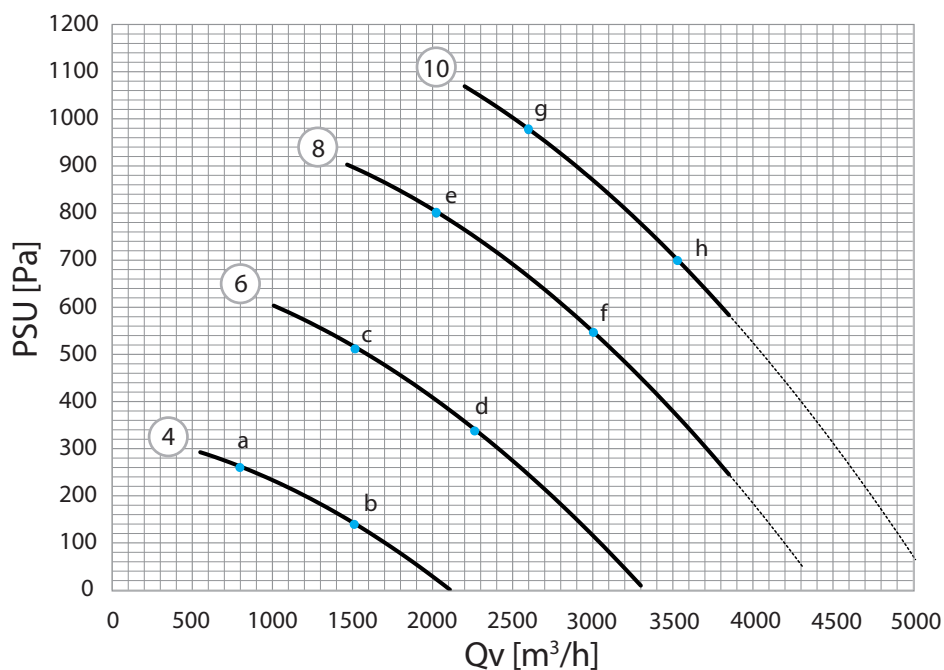

⊗ = control voltage  
 Psu = available static pressure  
 Qv = Air flow rate

ENY-PV5	a	b	c	d	e	f	g	h
Radiated Lw dB(A)	63.3	60.5	72.3	70.0	78.0	74.9	80.3	77.8
Supply Lw dB(A)	66.3	63.5	75.3	73.0	81.0	77.9	83.3	80.8
Extract Lw dB(A)	52.3	49.5	61.3	59.0	67.0	63.9	69.3	66.8

### Performance and absorption of the individual fan ENY-PV5

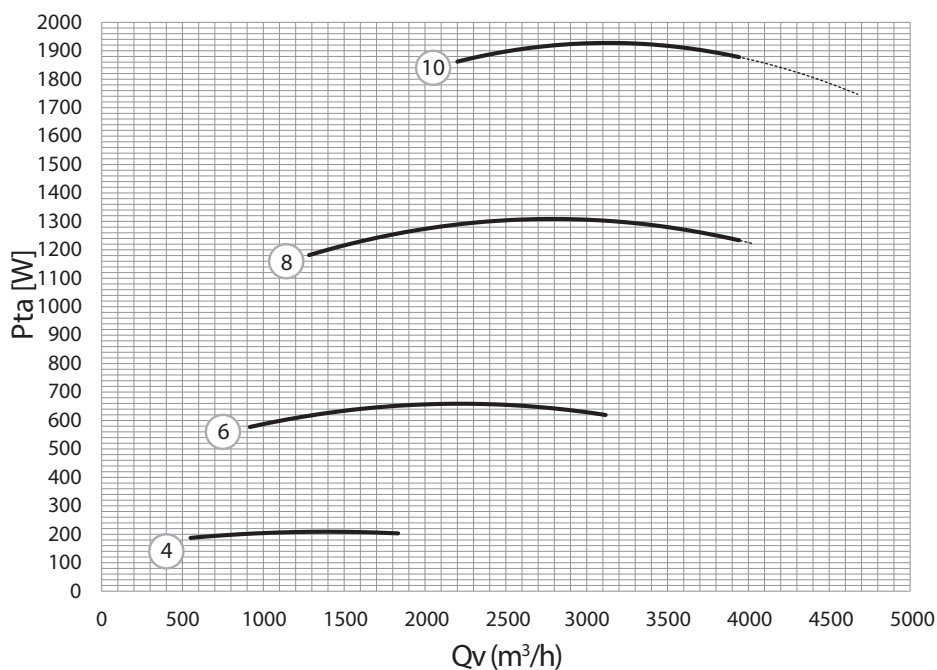

⊗ = control voltage  
 Pta = electrical power absorbed  
 Qv = Air flow rate

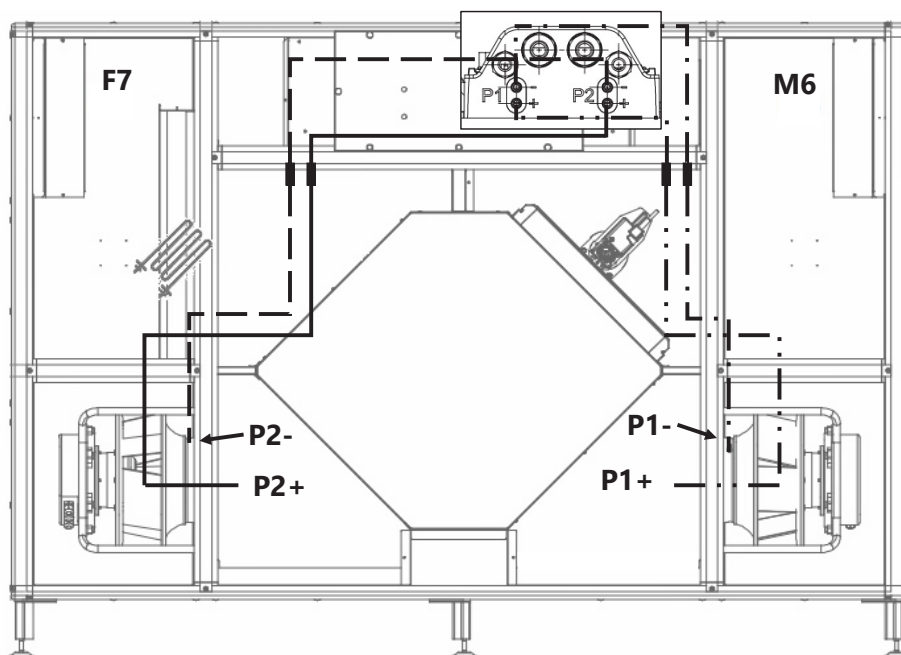
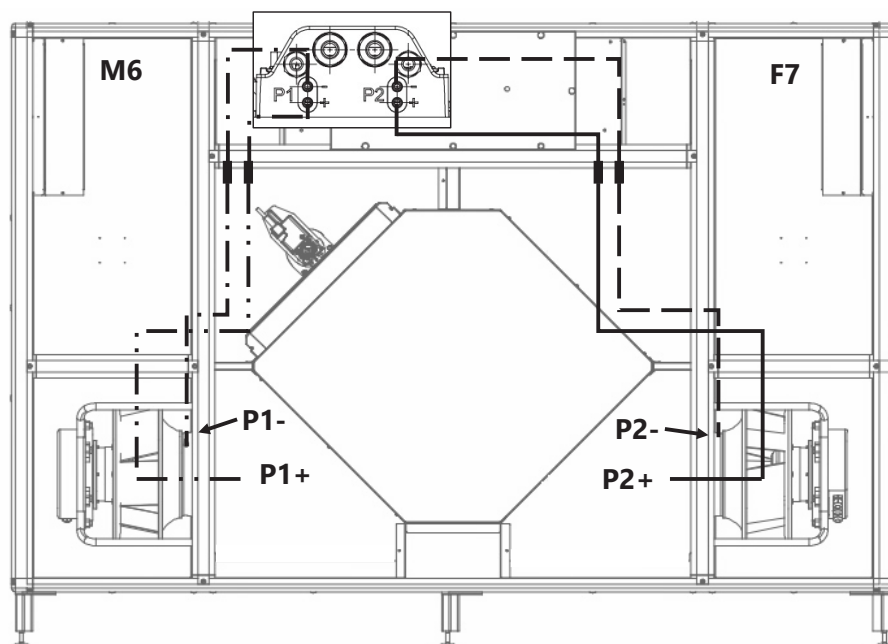
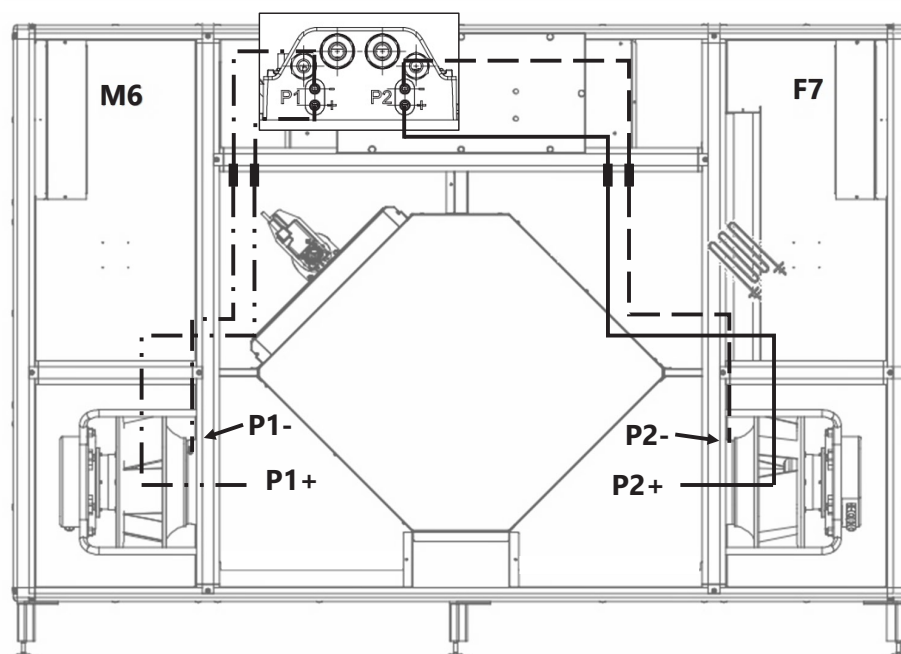

**ENY-PVx QEL****ENY-PVx QR****ENY-PVx QER**

## » **CONSTANT DIFFERENTIAL PRESSURE Units**

Two pressure outlets are applied between the upstream and downstream of the machine to measure the differential pressure at the ends of the unit in order to adapt to the variable flow rate demand by the local control systems. The pressure outlets are connected to the differential static pressure transducer inside the electrical panel, as shown in the following diagrams.

### KEY

Negative extraction pressure (P2-)	— — — —
Positive supply pressure (P1+)	- · - · - · - · -
Positive extraction pressure (P2+)	—————
Negative supply pressure (P1-)	- · — — — · -

### ENY-PVx DPL

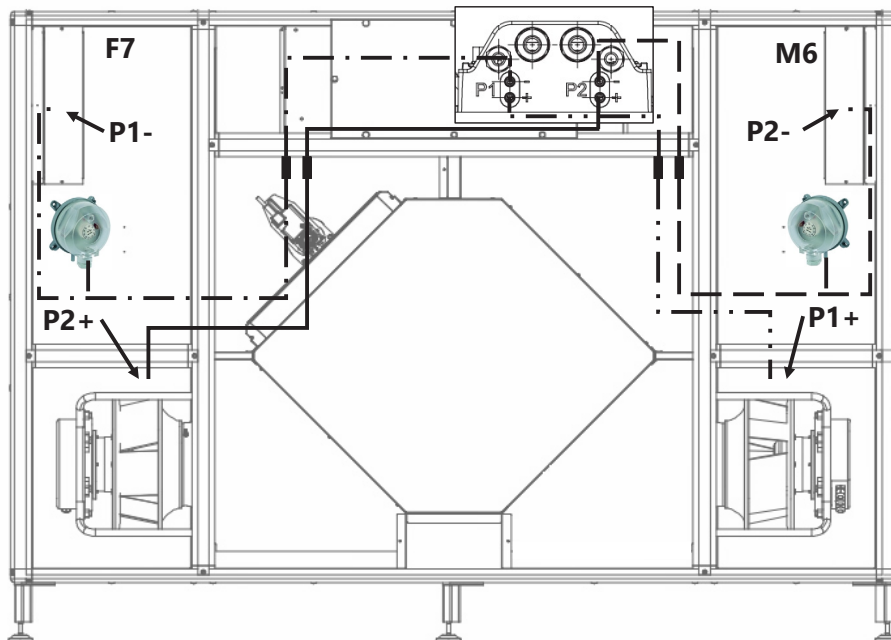

### ENY-PVx DPEL

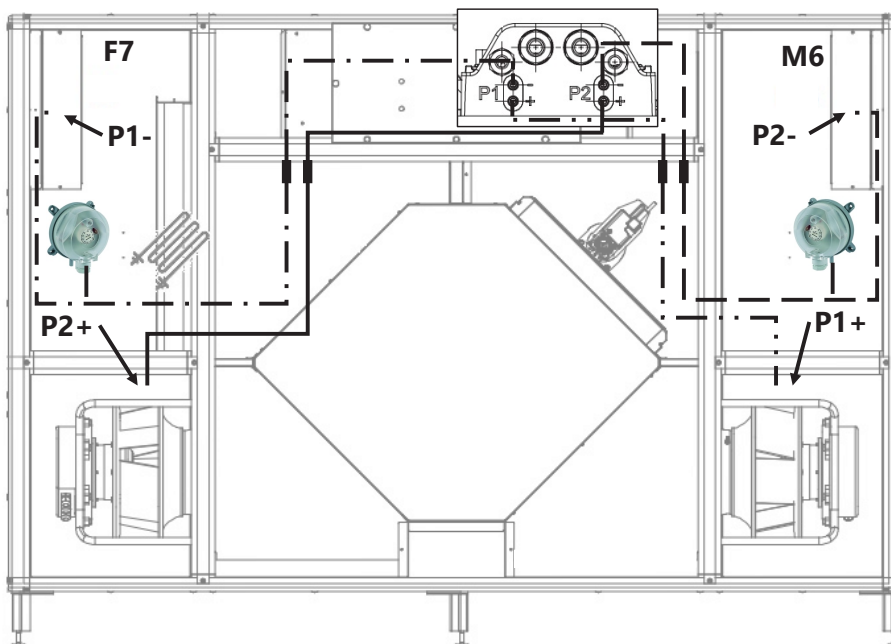

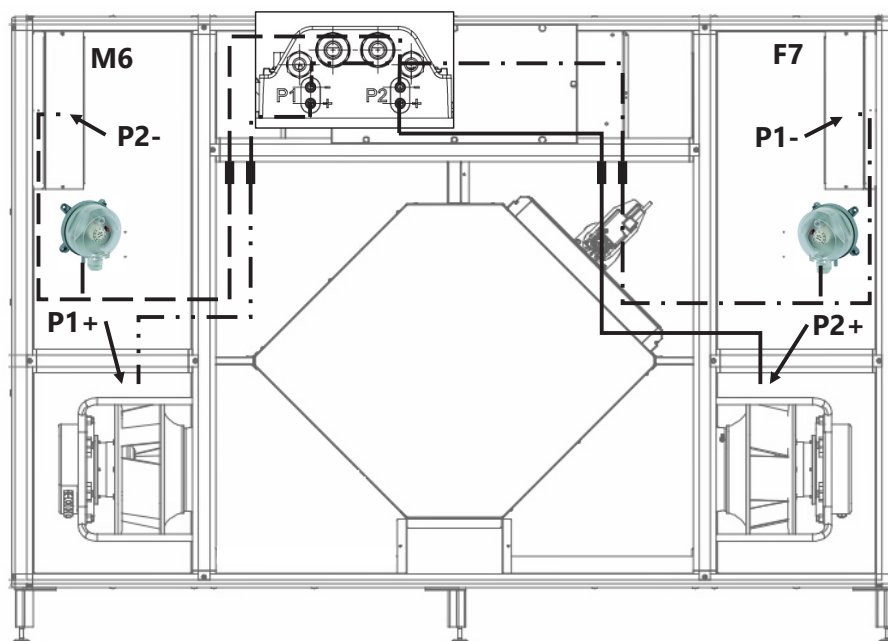
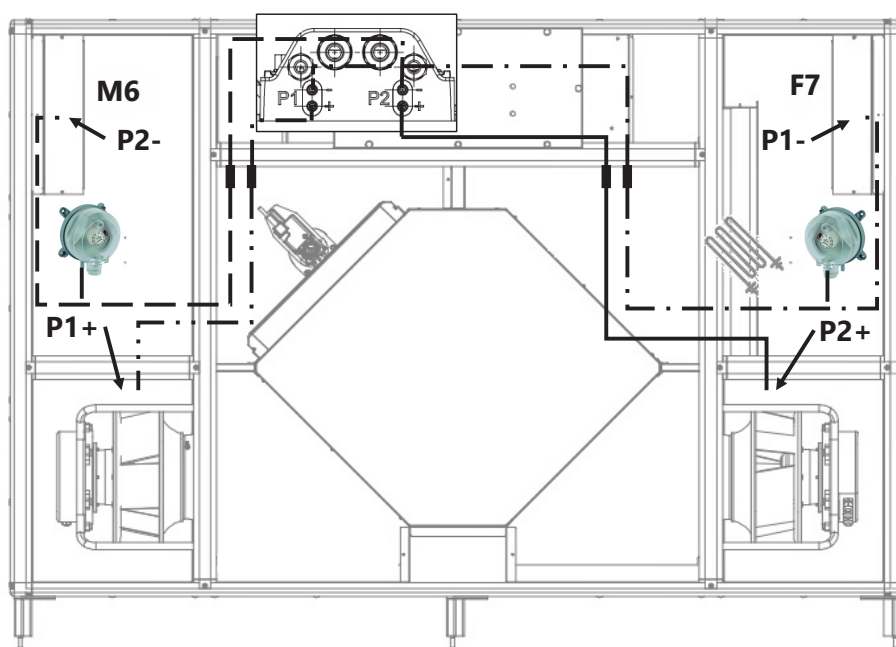
**ENY-PVx DPR****ENY-PVx DPER**

**CAUTION:** The pneumatic tubes are subject to maintenance as described in the relevant paragraph in this manual.

Changing the pneumatic connections compromises the machine's operation.

## ELECTRICAL CONNECTIONS

Upstream of the unit, provide an omnipolar switch (two in case of units with electric heater) with a contact opening distance that ensures complete disconnection in overvoltage category III conditions.

All electrical connections of the unit should be made by qualified staff.

The customer is responsible for providing a suitably sized power mains in compliance with the absorption parameters of the ventilation unit, declared in this manual.

### » *Electrical box panels topographic*

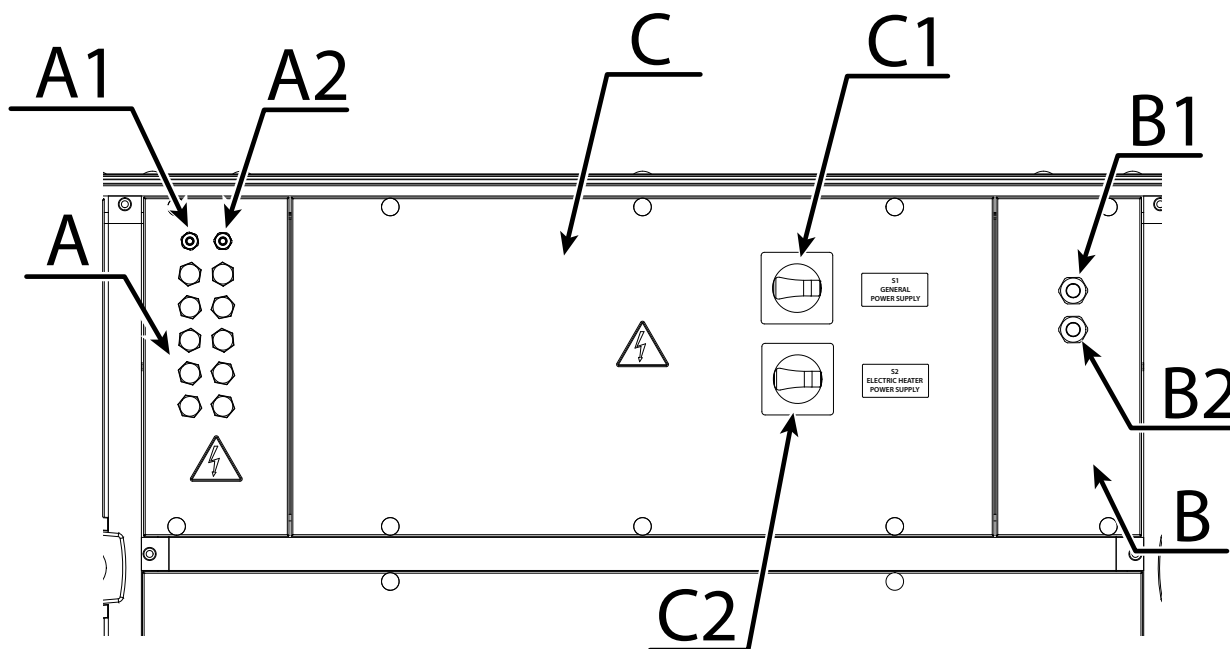

### Key

**A. AUXILIARIES** side inspection panel  
 A1. **PL-LINK** control input cable gland  
 A2. External probe general input cable gland

**B. POWER** side inspection panel  
 B1. Electronics and fan power supply input cable gland  
 B2. Internal electric heater power supply input cable gland (present and functional only in machines with internal electric heater)

**C. MAIN** electrical panel inspection panel  
 C1. Main circuit breaker (fans and electronics)  
 C2. Electric heater Circuit breaker (present and functional only in machines with internal electric heater)

**NOTE:** Panel "A" is supplied with 10 PG9 passages capped with removable rubber seals.

The supply of the PG9 cable glands for additional external auxiliaries other than the © Siemens **PL-Link** control and an external probe, are the responsibility of the installer.

## » Access to the electrical panel

To access the electrical panel:

1. Make sure that the **C1** circuit breaker (if machine with internal electric heater, circuit breakers C1 and C2) is set to **OFF**.

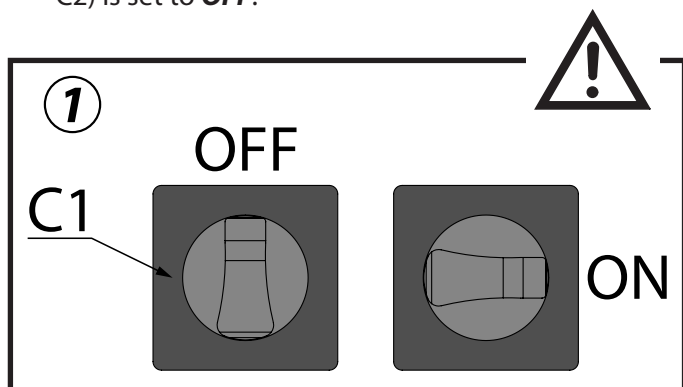

2. Remove the main electrical panel inspection panel "C";
3. Remove inspection panels "A" and "B" in succession.

It is now possible to fully access the electrical panel.

Close the inspection panels once the electrical connections have been made.

**NOTE:** pay attention to the centring pin "D" when extracting panels "A" and "B".

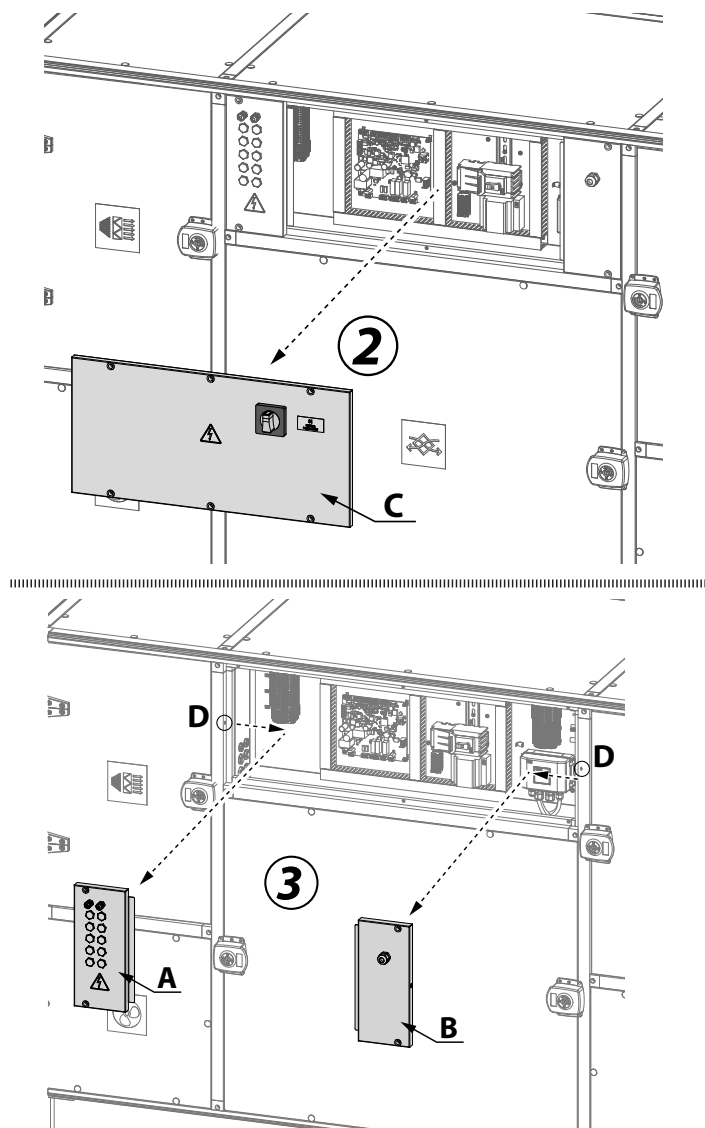

## » Electrical panel topographic

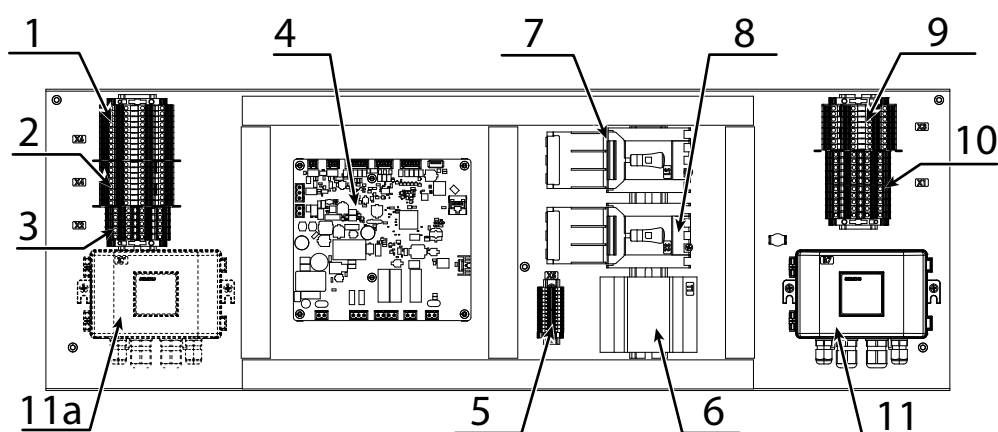

### Key

- |                          |  |
|--------------------------|--|
| 1. Terminal block X6     | 8. Electric heater Circuit breaker (present and functional only in machines with internal electric heater) |
| 2. Terminal block X4     | 9. Terminal block X3   |
| 3. Terminal block X2     | 10. Terminal block X1  |
| 4. Control Board         | 11. Differential Pressure Transducer   |
| 5. Terminal block X5     | 11a. Differential Pressure Transducer (right-side configuration unit)                                      |
| 6. 24V Power supply unit |  |
| 7. Main circuit breaker  |  |

## » Connection

Refer to the certified wiring diagrams, supplied with the unit.

### • Power supply

The power supply must comply with the specifications indicated on the data plate.

The power supply voltage must be within the range specified in the electrical feature table. For the connections, please refer to the certified wiring diagrams and dimensional drawings.

#### **CAUTION:**

After commissioning the unit, the power supply can only be deactivated for maintenance purposes. The units are equipped with a Main circuit breaker (supply of an additional circuit breaker if the unit has an internal electric heater).

### • Recommended cable sections

The installer is responsible for the sizing of the cable, which depends on the features and regulations applicable to each installation site. Once the sizing of the cables has been completed, the installer, using the certified dimensional drawings, must ensure to have identified a simple connection method and define any changes that may be necessary on site.

#### **IMPORTANT:**

Before connecting the main power cables (L1 - L2 - L3 - N - PE) on the terminal block, it is mandatory to check the exact order of the 3 phases. Then connect the aforementioned cables and the neutral wire correctly (an incorrect connection of the neutral conductor cable could irreversibly damage the unit).

### • Insertion of the control and power supply cables

The power supply cables must be inserted into the cable glands from the front of the unit.

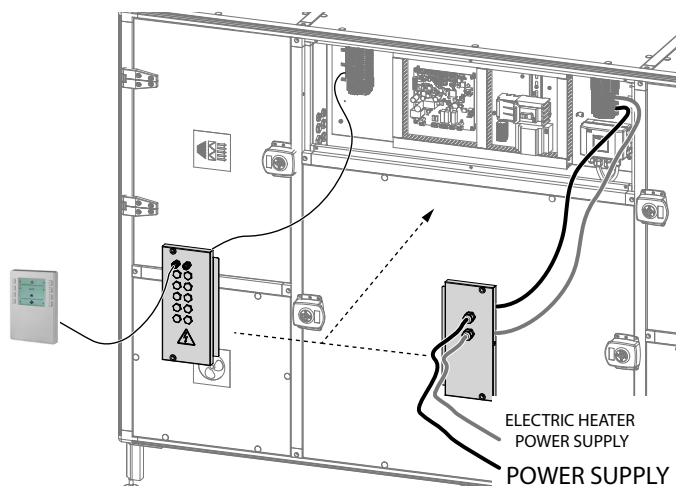

### • Electric power supply connections

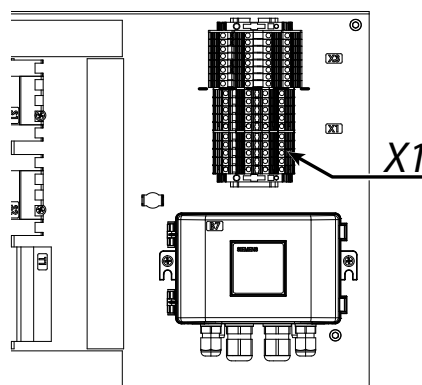

The units are supplied complete with electrical panel and the connections to the internal terminal blocks of the motors already made.

In this case, see to the connection of the power line to the main circuit breaker as described in the wiring diagram supplied.

In case of units with internal electric heater, in addition to the power line connection, it is necessary to connect the circuit breaker power line for the electric heater.

It is of extreme importance for the connection to the earth equipotential network to be carried out with due care, using cables of adequate section and quality, possibly conducted together with the power cables.

The power lines must be connected to the electrical panel "X1" terminal block.

Below are the connections of the power lines relating to the machine models divided by size and type:

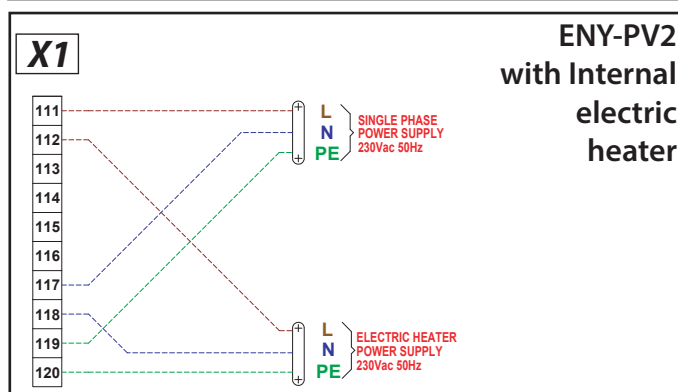
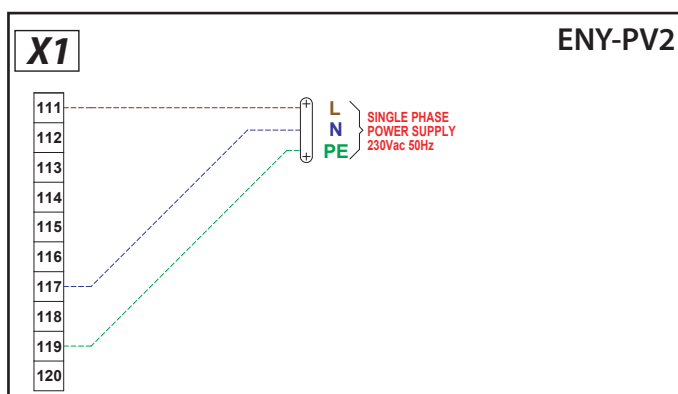

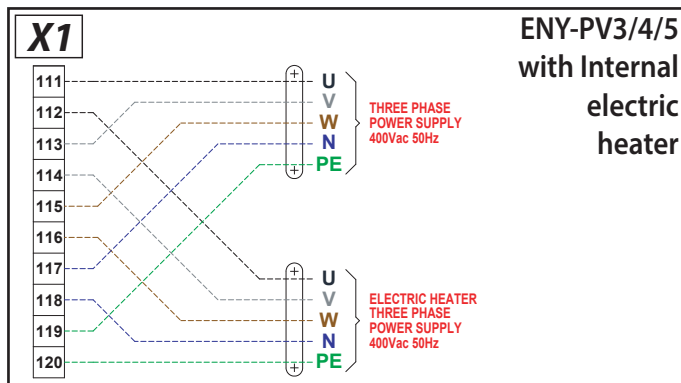
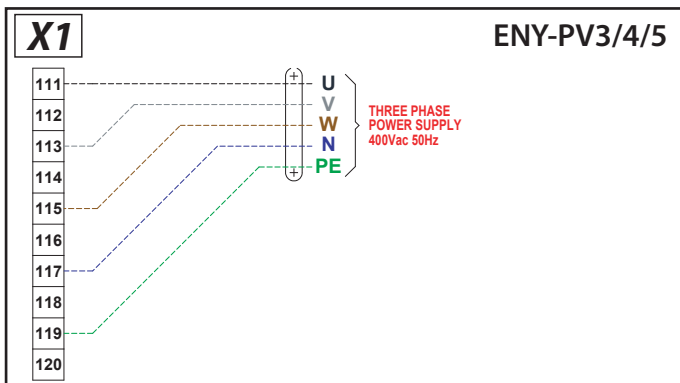

• **Auxiliary Contacts Connections**

The units are equipped with dedicated “X6” terminal block for connecting the auxiliary devices.

The following table lists the devices and related connections available by the installer

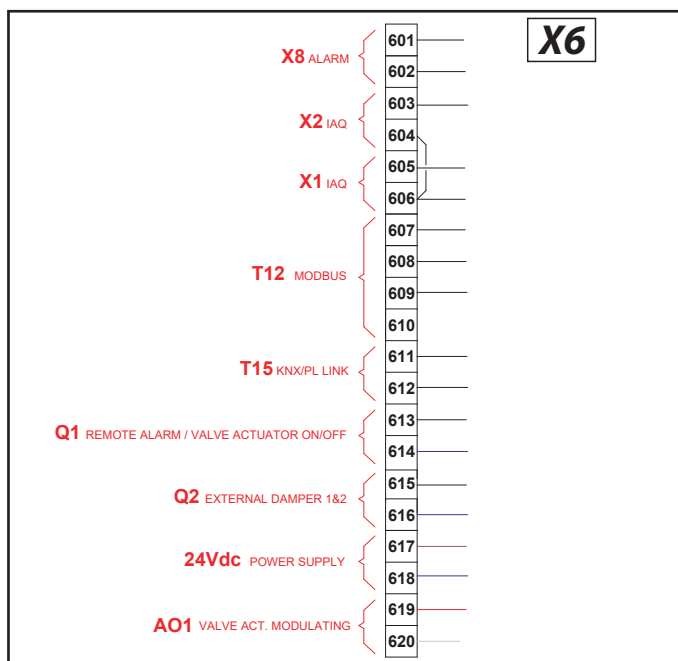

TERMINAL	DESCRIPTION	TYPE	TERMINALS
<b>X8 - ALARM**</b>	POST-TREATMENT heater safety thermostat	Dry contact NC Alarm alert (machine stop)	601 - 602
	POST-TREATMENT hydronic coil anti-freeze probe	NTC10k Probe Alarm alert (machine stop)	
<b>X2 - IAQ**</b>	Terminal for relative humidity sensor connection.	“Input signal - 0-10V”	“603 - 0-10 V 604 - GROUND”
<b>X1 - IAQ**</b>	Terminal for CO2 sensor connection	“Input signal - 0-10V Scale 0-2000 ppm”	“605 - 0-10 V 606 - GROUND”
<b>T12 - MODBUS</b>	Terminals for RS485 MODBUS connection	-	“607 - + 608 - - 609 - GROUND”
<b>T15 - © Siemens PL-Link</b>	Terminals for connecting the wall-mounted controller © Siemens <b>PL-Link</b>	-	“611 - + 612 - -”
<b>Q1 - REMOTE ALARM</b>	Remote control of the alarm signal. (Example: siren, beacon)	“Relay powered 24 Vdc NO”	“613 - L 614 - N”
<b>Q1 - VALVE ACTUATOR ON/OFF**</b>	Power supply ON/OFF for HEATING OR COOLING valve adjustment.	“Relay powered 24 Vdc Control logic post-treatment NO”	“615 - L 616 - N”
<b>Q2 - EXTERNAL DAMPERS</b>	Power terminal ON/OFF of external dampers.	“Relay powered 24 Vdc NO”	“615 - L 616 - N”
<b>AO1 - VALVE ACT. MODULATING**</b>	0-10V probe control and power terminal for HEATING OR COOLING valve	“0-10 V Output signal”	619 - 0-10 V 620 - GROUND”
<b>24 Vdc - POWER SUPPLY</b>	Auxiliary 24 Vdc power supply	“24 Vdc power supply”	“617 - 24Vdc 618 - 0V”

\*NO - Normally open / NC - Normally closed

\*\* THE FUNCTIONS MUST BE ACTIVATED THROUGH SPECIFIC CONFIGURATION OF THE ELECTRONIC BOARD WITH DEDICATED TOOL **ENY-PV MANAGER**

## CONTROL DEVICE

All the units are supplied with the © Siemens **PL-Link** wall control device.

**IMPORTANT!: These instructions are the property of © Siemens and granted for use to Sabiana Spa.**



### » DIMENSIONS

Unit of measurement: mm

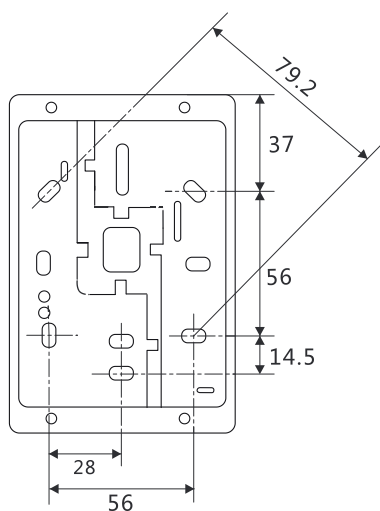
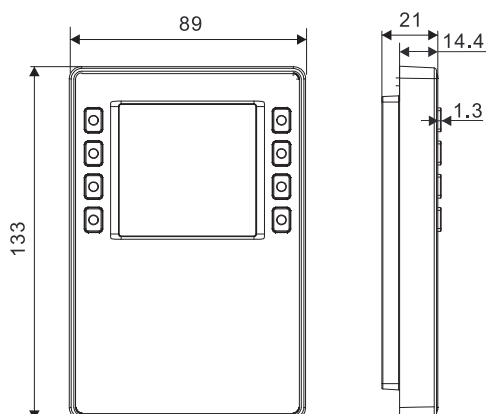

### » GENERAL AND CONNECTION WARNINGS

This section explains the general and specific regulations to control the network and operating voltages. It includes important safety information for people and the entire system.

Observe the following general rules during use:

- National electrical and mains power supply standards.
- Other applicable national regulations.
- National standards for installation in buildings.
- Company regulations for network supply.
- Diagrams, lists of cables, provisions, specifications by the customer or authorised technical department.
- Third party regulations, for example by the general contractor or building owner.

Electrical safety for building automation and Siemens control systems is essentially based on the safe separation of low voltage from mains voltage.

Pay attention during the design and installation of controllers and field devices with KNX® bus connection, to the permitted line lengths and types. Make sure that the bus power supply complies with the KNX® standard.

When installing cable ducts, separate the interfering cables from sensitive entities.

- Interfering cables: motor cables, in particular motors provided by inverter, power cables.
- Susceptible entities: control cables, low voltage cables, interface cables, LAN cables, digital and analogue signal cables.
- Both types of cables can be in the same duct, but in separate compartments.
- If a three-sided closed duct with separating wall is not available, the interfering cables must be separated by at least 150 mm from the others or located in separate ducts.
- The crossings of strongly interfering cables with potentially sensitive entity must be at right angles.
- In rare cases, the signal and interference power cables can be conducted in parallel, causing a high risk of interference.

It is recommended to use unshielded cables. Observe the manufacturer's installation recommendations when selecting unshielded cables. In general, unshielded twisted pair cables have sufficient EMC properties for technical construction applications (including data applications) and do not require coupling with the surrounding earth.

The device is considered an electronic device for disposal according to European Guidelines and cannot be disposed of as household waste.

Dispose of the device through the channels provided for this purpose.

Comply with local and currently applicable laws and regulations.

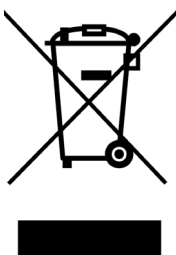

» **ELECTRICAL CONNECTION**

Connection cable requirements:

Max length 20 m.

Joint wiring with 230 V cables is not allowed.

Joint wiring with SELV AC or DC cables is allowed.

**R1** = © Siemens **PL-Link** device

**X6** = Auxiliary contact terminal block

Make the connection between the © Siemens **PL-Link** (R1) device and the **X6** terminal block.

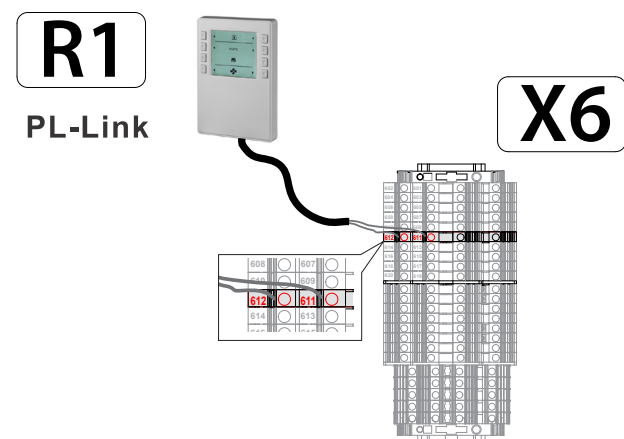

**Terminal connection**

Pin	Description
+	PL-Link / <b>POSITIVE</b> pole
-	PL-Link / <b>NEGATIVE</b> pole
<b>611</b>	X6 Terminal block / <b>POSITIVE</b> pole
<b>612</b>	Terminal block X6 / <b>NEGATIVE</b> pole

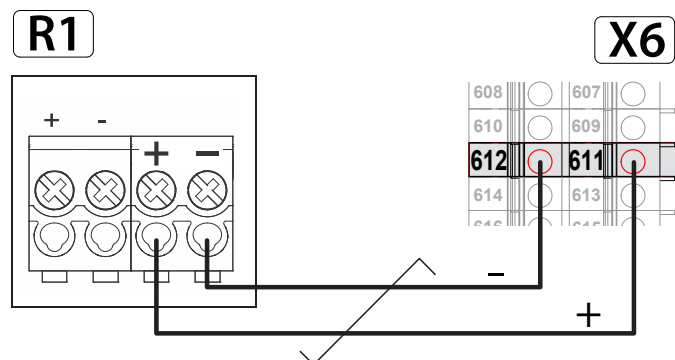

» **ASSEMBLY AND INSTALLATION**

Check the package contents for visible damage during transport and for completeness.

Do not install parts damaged during shipment. Contact the supplier in case of damaged parts.

Before reading these instructions for device use and installation, consult the technical data sheet with regard to:

- Climatic environmental conditions
- Protection ratings

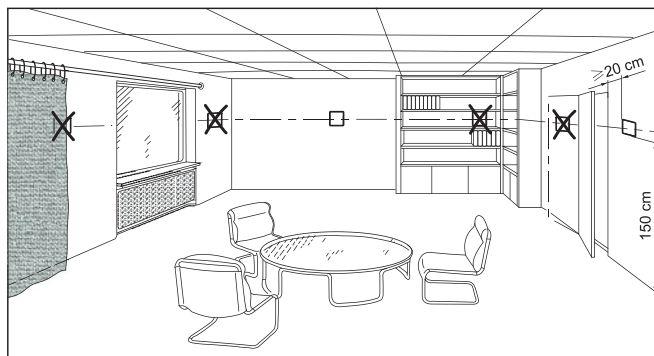

The devices are suitable for wall or panel mounting.

- Recommended height: 1.50 m from the ground.
- Do not fit the devices in niches, shelves, behind curtains or doors or above or near heat sources.
- Avoid direct sunlight and draughts.
- Observe the allowed environmental conditions.

For assembly, observe the assembly instructions provided with the devices.

**Wall Installation**

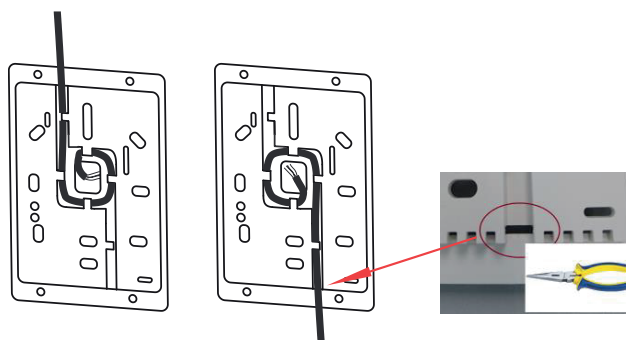

Remove the protective tab before inserting the cable into its housing.

If 4-wire cables are used for chain wiring, remove the cable covering to adapt it to the provided housing.

A6V1073377-1M02

### Assembly with wall cable ducts

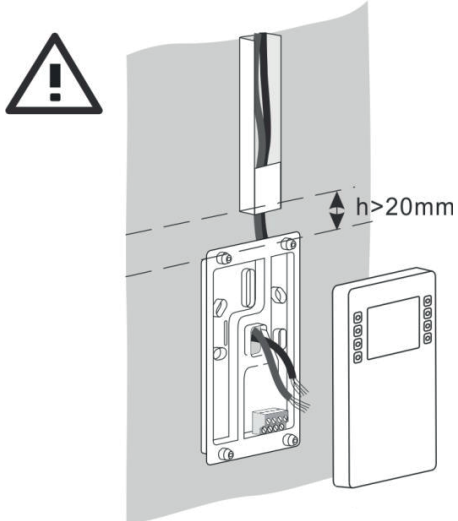

In order to hook the device cover to the base plate, keep at least 20 mm from any object such as cable ducts.

### Panel installation

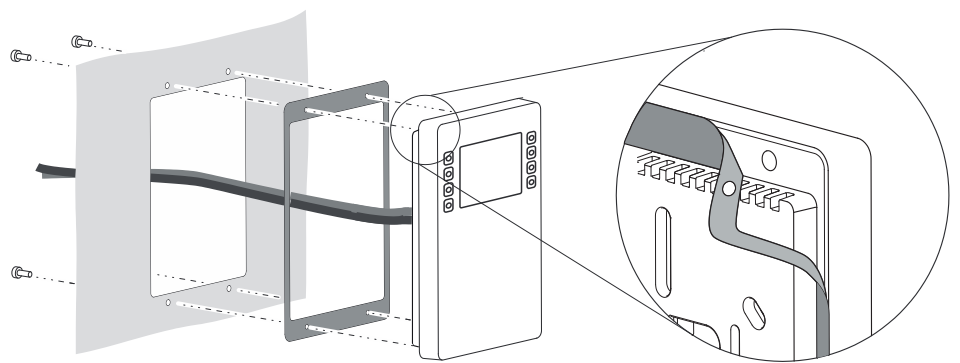
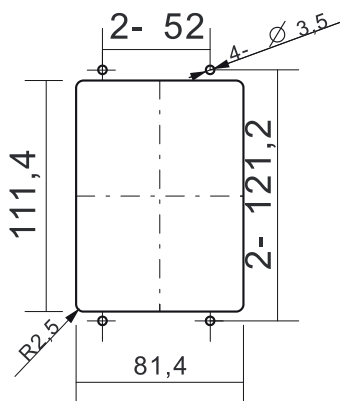

### Disassembly / Service

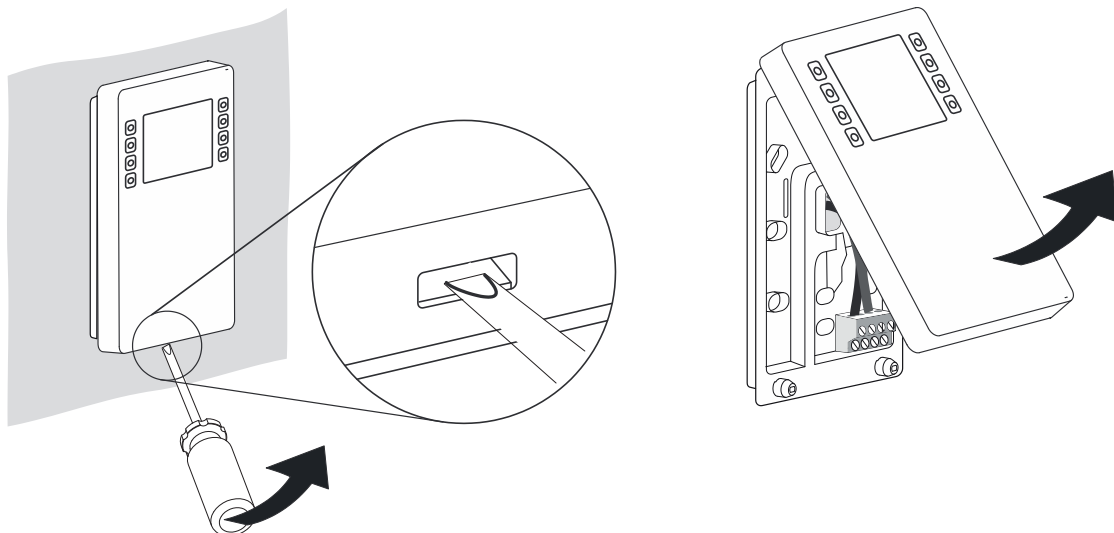

» **TECHNICAL DATA**



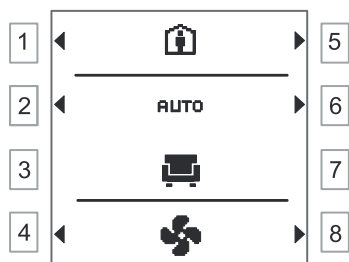



<b>Electric power supply</b>		
Operating voltage	KNX® PL-Link DC 21...30 V	
Maximum absorption	7...10 mA	
<b>Interface</b>		
Type of door between local operator unit and controller	KNX® PL-Link	
Baud rate	9.6 kbps	
Protocol	KNX® PL-LINK	
KNX® Standard Connector	Wire diameter 0.8 mm, max 1.0 mm (solid conductors only)	
Cable type	Twisted pair with 2 conductors, flexible, solid	
Single cable length (from the control board to the device)	<1000 m	
Section	0.5...1.5 mm <sup>2</sup>	
BUS line polarity	PL+, PL-	
BUS termination resistance	N/A	
<b>Sensor data</b>		
Temperature Sensor	Type of sensor	NTC sensor
	Measurement range	0...50°C
	Measurement precision (5 ... 30°C)	±0.8°C
	Measurement precision (25°C)	±0.5°C
<b>Environmental conditions and protection rating</b>		
Protection Rating	* IP30 * IP33 for the surface section	
Insulation class	Class III	
Climatic environmental conditions * Standard operation * Transport	* Environmental conditions: Class 3K5 Temperature 0 ... 50°C Air humidity <85% r.h. * Environmental conditions: Class 2K3 Temperature -25 ... 70°C Air humidity <95% r.h.t	
Mechanical environmental conditions Standard operation Transport	Class 3M2 Class 2M2	
<b>Standards, directives and approvals</b>		
EU compliance	CE	



## » FUNCTIONS

By pressing the keys on the wired control (shown in the figure with numbers from 1 to 8), it is possible to edit the machine settings and access the various device menus.

Symbols	Functions
	Operating modes: At home / Away from home / Temporary mode
	Temporary Mode: BOOST
	Ventilation Mode: Comfort / Economy / Unoccupied / Protection
<b>AUTO / MAN</b>	Auto / Manual
	Manual
	Ventilation mode menu
	Notifications Menu
	Home page/ Clock Menu
	General Settings / Expert Settings
	Indicates a usable element
	Wait
	Confirm
	Notifications list
	Active alarm herein not yet displayed and acknowledged by the user
	Past active alarm, the cause of which is no longer present, and not yet displayed and acknowledged by the user
	Alarm displayed and acknowledged by the user, although still active
	Alarm displayed and acknowledged by the user, the cause of which is resolved at present. The report can be deleted.
	Report not displayed
	Report not displayed and acknowledged by the user, the cause of which is no longer present
	Report displayed and acknowledged by the user, the cause of which is still active
	All notifications have been displayed
	Reset / return to default conditions
	Confirm
	Delete
	Go back
<b>&lt; / &gt;</b>	Exit / Next
<b>+ / -</b>	Increase / Decrease
	Add switching point
	Edit
	Delete

Symbols	Functions
1 2 3 4 5 6 7	1= Monday, 2= Tuesday, ... 7 = Sunday
00 06 12 18 24	Hours of the day
↓	Switching point
	Hourly programming time interval
	Unoccupied display
	Economy display
	Comfort display
P	Parameter Reading
	Outdoor Temperature
	Ambient Temperature

Use the keys to access the different device menus:

- Home page (Date and time).
- Ventilation mode.
- Weekly programming.
- Alarms.
- Settings

#### • Home Page (Date and Time)

The device date and time can be changed on the home page.

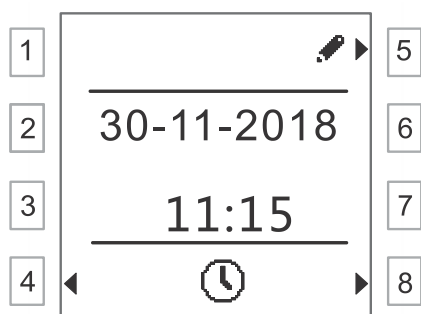

Keys 1, 2, 3, 6 and 7	Function not available (the indication arrow does not appear on display)
Key 5	Press to edit the date and time
Keys 4 and 8	Goes through the different menus: ventilation, notification and clock

#### • Ventilation mode

Pressing key 8 from the "**Home page**" gives access to the "**Ventilation mode**" menu.

Pressing buttons 1 and 5 gives access to the pages:

- At home
- Temporary mode
- Away from Home

#### • At home (default page)

Entering the ventilation menu gives access to the "**at home**" page.

Buttons 2 and 6 change the operating mode from AUTO to MAN.

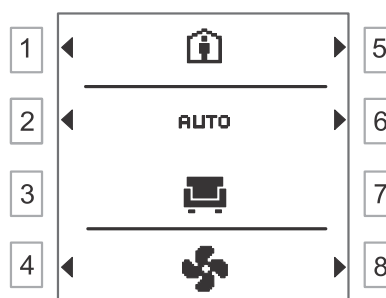

Keys 1 and 5	Switches between at home mode, temporary mode and away from home mode
Keys 2 and 6	Switches between AUTO and MANUAL mode
Keys 3 and 7	- In AUTO mode: no function (the arrow symbols are not present). - In MANUAL mode: switches between Comfort, Economy, Unoccupied and Protection ventilation modes.
Keys 4 and 8	Goes through the different menus: Home, Ventilation and Notifications menu

In **AUTO** mode, the unit is controlled according to the set weekly program.

The ventilation mode is only displayed; to change it, access the weekly programming menu.

In the event air quality sensors are installed and the electronic board is correctly configured, the ventilation units work automatically at variable flow rate depending on the readings from the sensors.

The pressure/flow rate setpoint is defined by the set ventilation mode which is fixed, if from **PL-LINK** manual mode is chosen, or subject to the hourly program, if from **PL-LINK** the "**AUTO**" mode is chosen.

In **MAN** mode, the wall-mounted control makes it possible to manually select the following ventilation modes:

- **Economy:** this is the standard ventilation mode corresponding to the project settings.
- **Comfort:** this is the hyperventilation mode.
- **Unoccupied:** this is the attenuated ventilation mode designed for when the room to be ventilated is partially or totally occupied.
- **Protection:** this is the standby mode of the unit. The fans are stopped.

**NOTE:** In order for the unit to work at a variable flow rate in response to the need to improve the air quality, it is necessary to install air quality sensors and change the main electronic board configuration as described in the paragraph "First machine start-up".

• **Temporary Mode**

From the "At Home" page, press key 5 to access the "Temporary Mode" page.

Press key 7 to activate the **BOOST** mode: the unit is set to Hyperventilation comfort mode for a specified time of 1 hour.

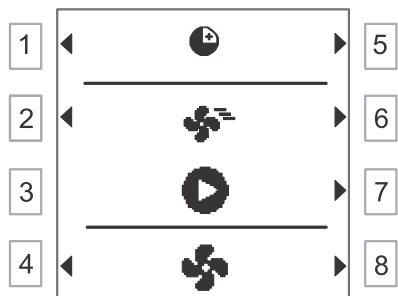

Keys 1 and 5	Switches between at home mode, temporary mode and away from home mode. When active , stops the BOOST prematurely.
Keys 2 and 6	Function not available
Key 3	Function not available (the indication arrow does not appear on display)
Key 7	Press to start the <b>BOOST</b> ventilation mode (A timer screen appears upon start-up, that indicates the duration)
Keys 4 and 8	Goes through the different menus: Home, Ventilation and notifications menu

Display of the **BOOST** start screen.

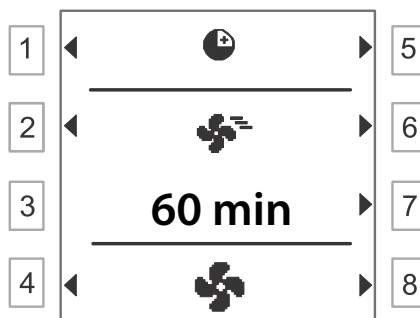

• **Away from Home Mode**

From the "Temporary Mode" page, press key 5 to access the "Away from Home" page.

By accessing it, the machine will go to "Unoccupied" mode regardless of the weekly programming.

If you have switched from "Manual" mode to "Away from Home" mode, when you exit the latter you will go back to the previous "Manual" mode.

If, instead, switching took place from the "Auto" mode, when you exit the "Away from Home" mode, the machine will enter the ventilation mode regardless of the weekly programming.

In "Away from Home" mode, the following are displayed:

- the ambient temperature
- the time

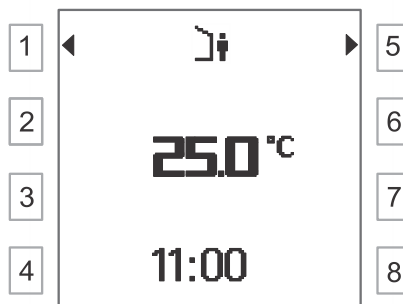

Keys 1 and 5	Switches between at home mode, temporary mode and away from home mode. When active, it stops the "Away from Home" mode prematurely.
Keys 2, 3, 4, 6, 7 and 8	Function not available (no indicator arrow displayed)

**Weekly Program**

From the "Ventilation mode" menu, on the "At home" page, press and hold key 2 for a long time to access the weekly programming

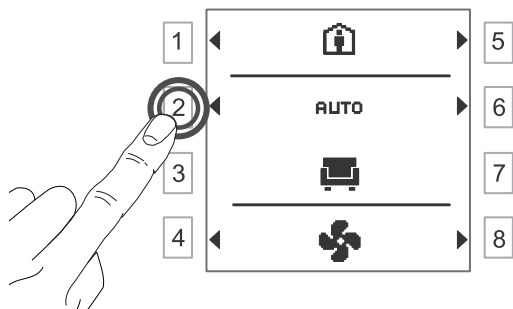

The display will show:

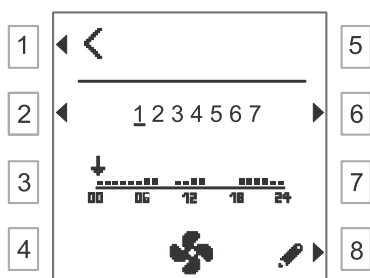

Key 1	Press to exit and save the settings
Keys 2 and 6	Press to select the week day
Keys 3, 4, 5 and 7	Function not available (the indication arrow does not appear on display)
Key 8	Press to change the weekly program for the chosen day

**Tables of settings for the preset weekly program**

The unit is set up with a factory set weekly program for its quicker start-up.

**Weekly program for commercial establishments (From Monday to Sunday)**



- Unoccupied** = 00:00 - 07:00
- Economy** = 07:00 - 20:00
- Unoccupied** = 20:00 - 00:00

**Weekly program change - Added switching points**

The weekly program can be customised to adapt it to your own needs by adding switching points. Proceed as follows to set new switching points:

Selecting a day of the week and pressing key 8 gives access to the programming editing page for the selected day.

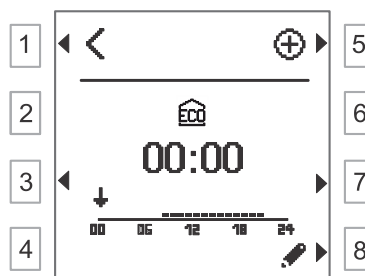

Key 1	Press to exit and save the settings
Keys 2, 4 and 6	Function not available (the indication arrow does not appear on display)
Keys 3 and 7	Switches between the switching points to view the preset program
Key 5	Press to add a switching point
Key 8	Press to change the switching point

The displayed time represents the start time of the switching point.

The end time is not displayed because it matches the start time of the next switching point.

The icon above the time represents the switching point ventilation mode.

Press key 5 to access the add switching point menu

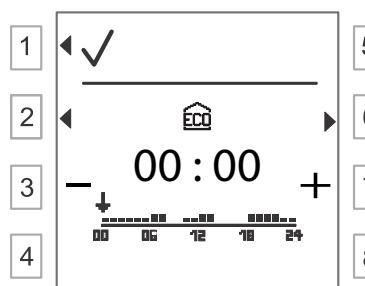

Key 1	Press to exit and save the settings
Keys 2 and 6	Press to select the type of ventilation to be associated with the switching point
Keys 3 and 7	Press to set the start time of the switching point
Keys 4, 5 and 8	Function not available (the indication arrow does not appear on display)

• **Practical example**

NOTE: After selecting the day of the week, press key 8.

Press key 5 to select a time using keys 3 and 7 and the ventilation mode using the arrows (2/6).

In the following image the **ECONOMY** ventilation mode activates in the morning from 7a.m. to 8p.m.

The purpose is to reduce this range by one hour (7a.m. – 7p.m.) and apply the **UNOCCUPIED** mode for the remaining one hour.

Press key 1 (✓) to confirm the change.

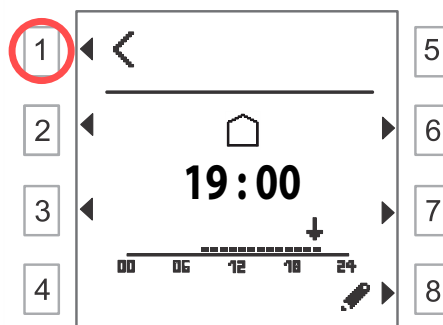

The weekly program is modified as requested.

The chosen ventilation mode has been modified

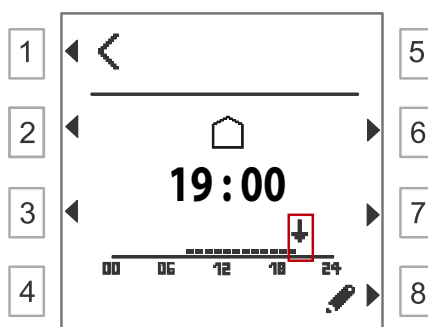
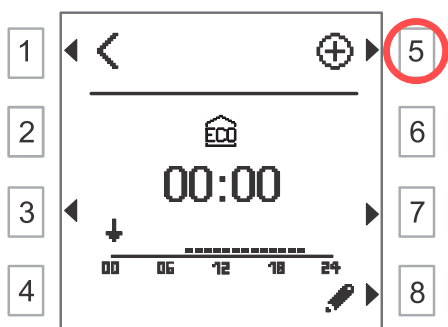

Press key 5 (⊕).

Using keys 7 (+) or 3 (-) shifts to 19:00 hours.

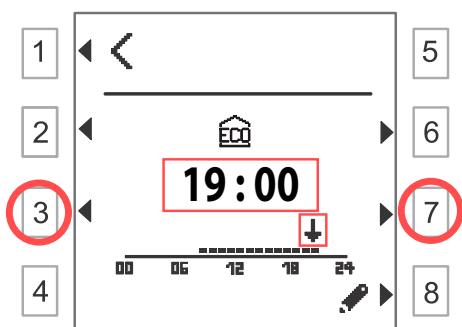

Using keys 2 (◀) or 6 (▶) selects the ventilation mode **UNOCCUPIED**.

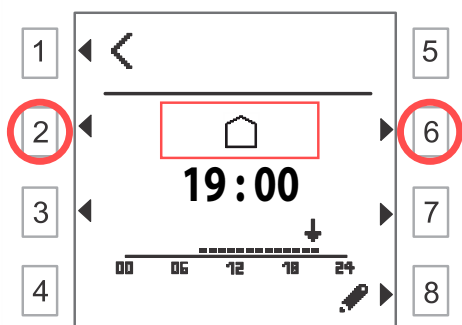

## • Alarms

The command displays the alarm state through the “**Notification page**”.

The alarms are displayed on the command with numerical codes and differentiate in “**Alarms**” (type 1) that involve stopping the machine and “**Signals**” (type 2) that do not stop the machine but can limit some of its functions.

The machine automatically recognises when the alarm condition is no longer present and signals it by changing the icon on the command in the relative menu.

To reset the alarm, it is necessary to have already viewed/acknowledged the signal provided by the device.

### Notification menu without active alarms

In the absence of active alarms, it is possible to go to the “**Notification**” menu page by pressing button 4 or 8.

In this case, the screen will appear as follows:

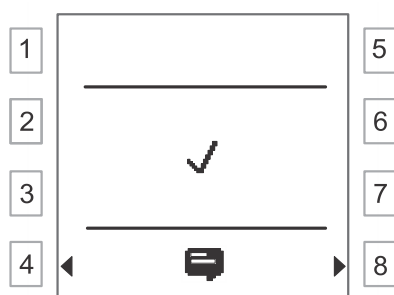



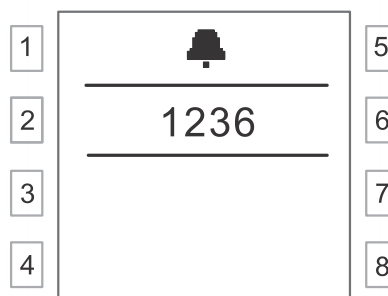

## • Alarms (type 1)

In case an event occurs that involves a type 1 alarm, regardless of the page being consulted, a screen will automatically appear identifying the alarm state and code (e.g. alarm 1236).



A bell icon appears on line 1-5 to identify the type of alarm:

	Active alarm herein not yet displayed and acknowledged by the user
	Alarm displayed and acknowledged by the user, although still active
	Past active alarm, the cause of which is no longer present, and not yet displayed and acknowledged by the user
	Alarm displayed and acknowledged by the user, the cause of which is resolved at present. The report can be deleted.

Press any button to automatically access the Notification page from where to perform the following operations:

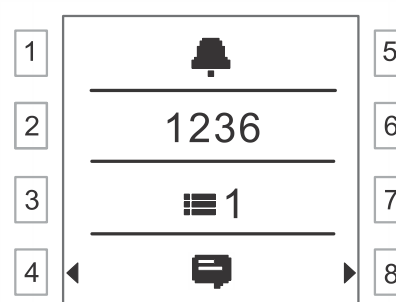



**Note:**  1 stands for *type 1*: alarm notification.

The alarm notification screen displays the last detected alarm, which overlaps any previous alarm.

Once the shown alarm has been resolved, the screen signalling the previous alarm will reappear which can be dealt with at a later time.

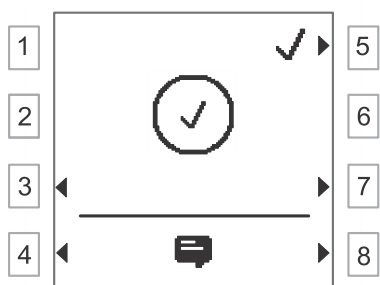
Pressing 3 or 7 accesses the page where to communicate to the ventilation unit control board that the alarm has been displayed and acknowledged by the user. The decryption table of each alarm based on the highlighted code will be shown below.



Once the problem has been operationally resolved, the ventilation unit will not restart yet but the display will show the icon  and it will be possible to proceed with the reset.



Press button 5 to communicate to the central electronic board of the aforementioned alarm acknowledgement. The following is displayed while waiting for feedback from the controller.

Press button 7 to access the reset page. Press button 3 or 7 in the reset page to go from the notification page to the reset page.

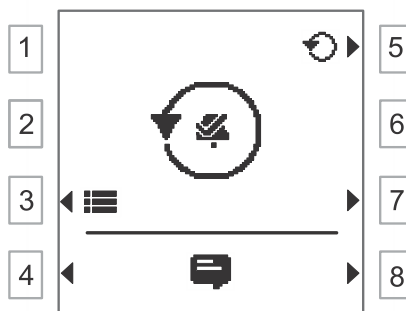
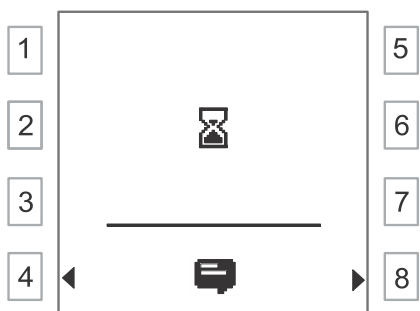

Once the alarm has been acknowledged by the user, in the notification screen the bell of the alarm still active is now represented by an overlapped tick. Therefore, operationally resolve the condition that caused the alarm on the machine.

Press button 5 to reset. The notifications  are eliminated after the reset. At the end of the process, the default screen of the notification page appears where no alarm state is displayed.

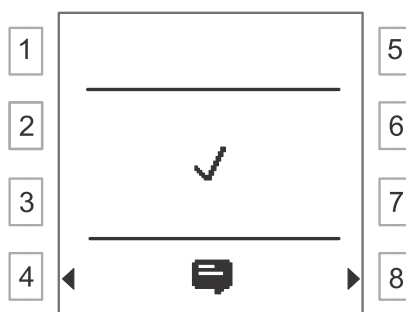

It is not sufficient to practically solve the cause of the alarm in order for the machine to restart correctly, but it is necessary to perform the alarm acknowledgement procedure described above.

Furthermore, the alarm signal must be restored.

Below is the specific table of possible alarms with relative codes and any required actions.

<b>Event</b>	<b>Description</b>	<b>Actions Required</b>
1001	Supply temperature: sensor disconnected/faulty.	Check that the probe is connected as per the manual, and, if necessary, replace it.
2001	Fans failure	Failure of the fans. call the Technical Assistance for the replacement
2004	Fire alarm	The supply or outdoor temperature probes have reached the protection limit values.
2007	Hot post-treatment coil: safety temperature exceeded	Limit temperature reached for risk of freezing of the hot coil.
2010	Post-treatment electric heater: safety temperature exceeded	Safety thermostat tripped: The heater has exceeded the maximum temperature allowed.
2012	Pre-treatment electric heater: safety temperature exceeded	Safety thermostat tripped: The heater has exceeded the maximum temperature allowed.

Under certain conditions, a screen may be displayed with an icon .

This icon identifies that there was an active alarm, the cause of which is no longer active or has been resolved but has never been viewed and acknowledged by the user.

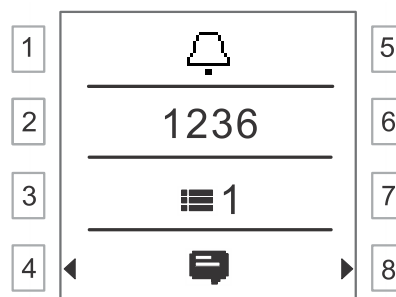

This situation causes the machine to stop.

In order to restore normal machine operation, it is necessary to perform the alarm acknowledgement, display and reset procedure.

Press any button to automatically access the Notification page from where to perform the following operations:

Pressing 3 or 7 accesses the page where to communicate to the ventilation unit control board that the alarm has been displayed and acknowledged by the user.



Press button 5 to communicate to the central electronic board of the aforementioned alarm acknowledgement.

The following is displayed while waiting for feedback from the controller.

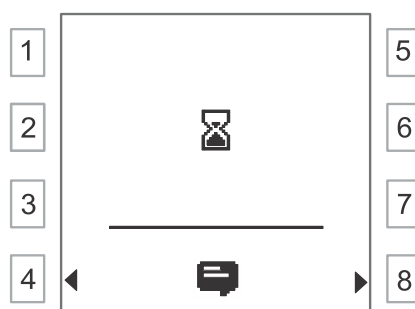

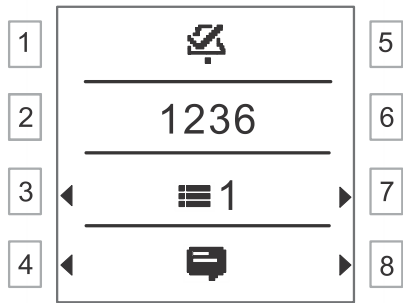

**CAUTION!:** If the machine shows codes that are not present in the following table, contact the technical assistance.

Once the alarm has been acknowledged by the user, the ventilation unit will not restart yet but the display will show the icon  and it will be possible to proceed with the reset.

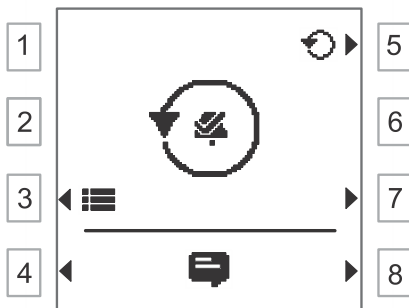

Press button 7 to access the reset page.  
Press button 3 or 7 in the reset page to go from the notification page to the reset page.



Press button 5 to reset.  
The notifications  are eliminated after the reset. At the end of the process, the default screen of the notification page appears where no alarm state is displayed.

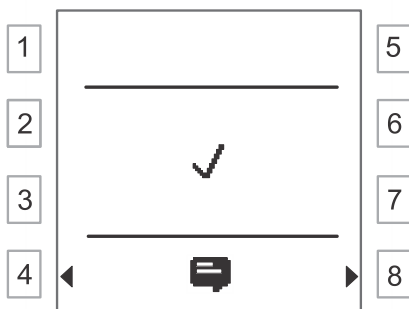

• **Signals (type 2)**

Unlike the Type1 Alarms, the Signal screen does not appear on top of the current PL-Link screen at the onset of the signal itself.

The signals do not involve stopping the machine and are displayed as follows in the Notification page:

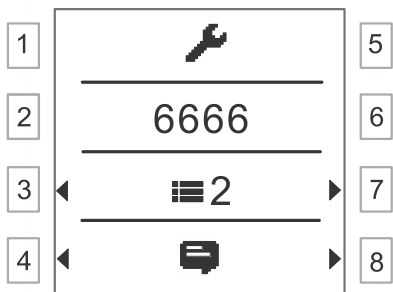

**Note:** 2 stands for *type 2*: Signal.

The notification screen displays the last detected signal, which overlaps any previous signal. Once the highlighted signal has been resolved, the previous signal screen will reappear which can be dealt with at a later time.

However, the alarms are always displayed with priority of importance over the signals.

An icon appears on line 1-5 that identifies the type of signal:

	Report not displayed
	Report displayed and acknowledged by the user, the cause of which is still active
	Report not displayed and acknowledged by the user, the cause of which is no longer present

As for the Alarms, in order for the notification to be reset, for the signals it is also necessary to go through the acknowledgement procedure.

However, unlike the alarms the reset is automatic and not subject to operator confirmation, as no restart command of the ventilation unit is required.

Press buttons 3 or 7 to acknowledge the signal:

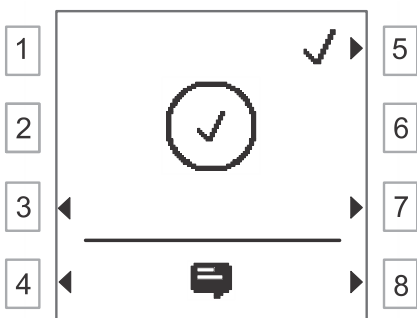

Press button 5 to communicate acknowledgement of the signal to the central electronic board.

The following page is displayed while waiting for feedback from the controller.

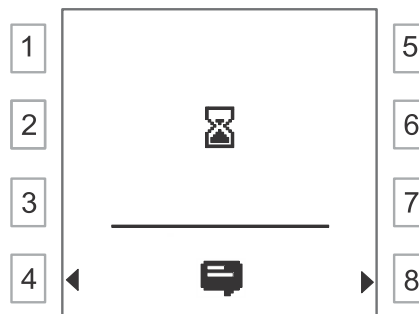

Following acknowledgement of the Signal, a tick appears on the signal icon.

Until the practical problem is solved, the background remains full

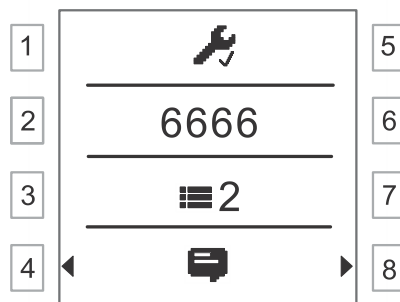

The Signals do not cause the machine to stop, therefore, to proceed with the reset it will not be necessary to restart the machine but simply for the condition that caused the alarm to no longer be present.

In fact, once the practical issue has been solved, the Signals disappear from the notification page.

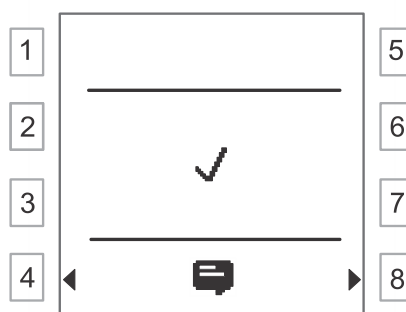

Below is the specific table of possible Signals with relative codes and any required actions.

<b>Event</b>	<b>Description</b>	<b>Actions Required</b>
1002	Expulsion temperature: sensor disconnected/faulty.	Check that the probe is connected as per the manual, and, if necessary, replace it.
1003	Extraction temperature: sensor disconnected/faulty.	Check that the probe is connected as per the manual, and, if necessary, replace it.
1004	Outdoor temperature: sensor disconnected/faulty.	Check that the probe is connected as per the manual, and, if necessary, replace it.
1006	Humidity sensor: sensor disconnected/faulty	Check that the probe sensor is connected as specified in the manual and, if necessary, replace it
1012	Wall-mounted controller temperature probe disconnected or faulty	Ambient temperature not detected by the wall-mounted controller. The command is disconnected or the temperature probe inside it is not working.
1014	Extraction air quality sensor (duct), sensor disconnected/faulty	Check that the probe sensor is connected as specified in the manual and, if necessary, replace it
1018	Exhaust temperature: sensor disconnected/faulty	Check that the probe is connected as specified in the manual and, if necessary, replace it. <b><i>The electric heater will not start working if the alarm is present.</i></b>
1020	Air filter sensor: dirty filters or sensor disconnected/faulty.	Replace the filters.
1032	Differential pressure sensor in supply: sensor disconnected/faulty	Check that the pneumatic tubes are properly connected to the P1 Terminal differential pressure sensor. The supply fan is adjusted with respect to the extraction fan. If alarm 1033 is also present, the fan is adjusted to constant speed according to the set setpoint.

<b>Event</b>	<b>Description</b>	<b>Actions Required</b>
1033	Differential pressure sensor in extraction: sensor disconnected/faulty	Check that the pneumatic tubes are properly connected to the P2 Terminal differential pressure sensor. The extraction fan is adjusted with respect to the supply fan. If alarm 1032 is also present, the fan is adjusted to constant speed according to the set setpoint.
1034	Differential pressure sensor on supply fan: sensor disconnected/faulty	Check that the pneumatic tubes are properly connected to the P1 Terminal differential pressure sensor. The fan is adjusted to constant speed according to the set setpoint.
1035	Differential pressure sensor on extraction fan: sensor disconnected/faulty	Check that the pneumatic tubes are properly connected to the P2 Terminal differential pressure sensor. The fan is adjusted to constant speed according to the set-point set.
2005	Supply temperature outside the operating limits	Supply temperature signal below 10°C.
3101	Communication with wall-mounted controller lost	Check the PL Link connection wiring to the unit

**CAUTION!: If the machine shows codes that are not present in the following table, contact the technical assistance.**

## • Parameter Settings

From the "Home page", press keys 6 and 8 to access the parameter settings page as shown below:

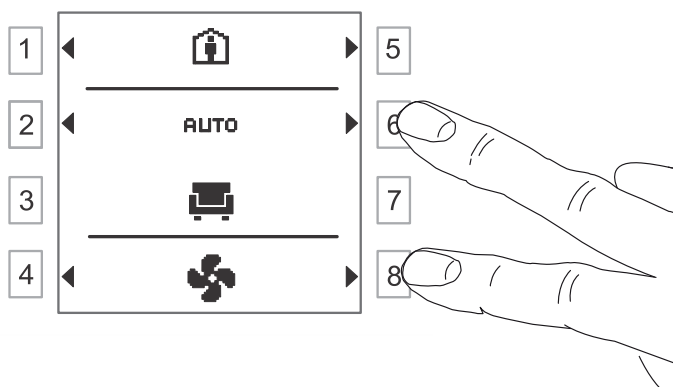

The display will show:

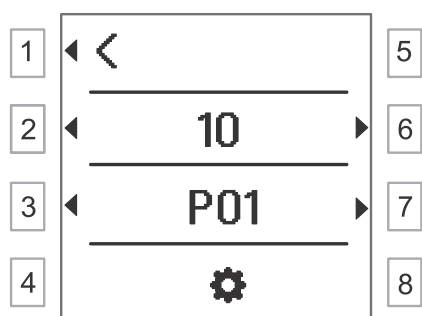

Key 1	Press to exit and save the settings
Keys 2 and 6	Value setting field
Keys 3 and 7	Choice of parameter
Keys 4, 5 and 8	Function not available (the indication arrow does not appear on display)

The editable parameters are:

	Description	Default Value
P01	Backlight level: 1, 2,..., 10	5
P02	Type of standby page: 1, 2,..., 5	1
P03	Correction of the ambient temperature: -3,0... 3.0 K	0.0K
P04	Temperature unit of measurement: °C and °F	°C
P05	Date Format: DD-MM-YYYY; MM-DD-YYYY; YYYY-MM-DD	DD-MM-YYYY
P51	Factory RESET by pressing button 6	N/A

## • Standby

When no operation is performed on the screen for a certain period of time, the backlight automatically turns off and the standby page is displayed.

There are 5 types of standby pages.

Users can select the desired standby page from the P02 standard settings.

Press any button to activate the backlight and any other button to access the home page.

The type 1 standby page is shown below.



## FIRST START-UP COMMISSIONING

The ENY-PV Commercial Recovery Units are pre-configured in the factory with the following default settings.

### » Unit with constant flow rate control

The basic operating logic of the units is based on an idea that there is a permanent operating flow rate that corresponds to that of the project or selection of the machine.

The PL-LINK control makes it possible to select the project flow rate by activating the "Economy" mode.

There are also temporary hyperventilation operating modes (30% more than Economy – "Comfort" mode) or night-time or holiday attenuation (50% of the project value – "Unoccupied" mode).

The units are pre-configured in the factory with preset settings for each of the aforementioned ventilation modes.

Model	[m³/h]	[m³/h]	[m³/h]
ENY-PV2	850	1100	425
ENY-PV3	1550	2000	775
ENY-PV4	2300	3000	1150
ENY-PV5	3000	3850	1500

\* the UNOCCUPIED mode flow rates are set at 50% of the ECONOMY value.

The present ventilation modes can be individually selected using the wall-mounted controller or can be combined in a weekly program that can be set using the same controller.

In order to modify the factory settings, it is necessary to use the PC tool ENY-PV Manager.

The available control curves are shown below:

### ENY-PV2

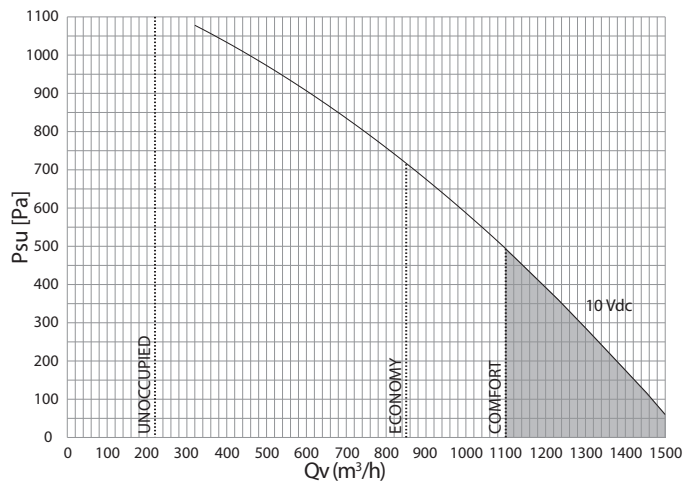

Psu = available static pressure  
Qv = Air flow rate

### ENY-PV3

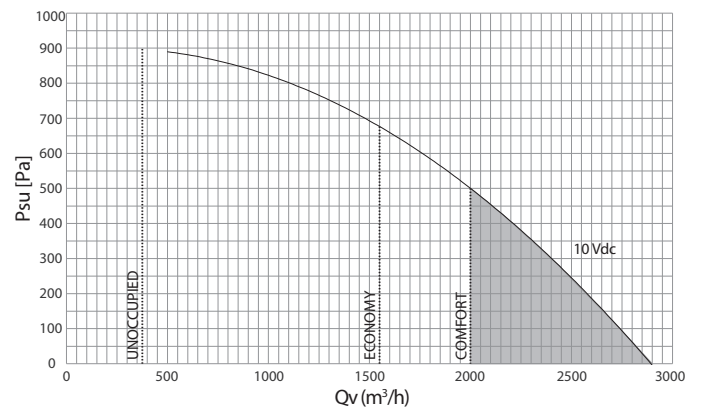

Psu = available static pressure  
Qv = Air flow rate

### ENY-PV4

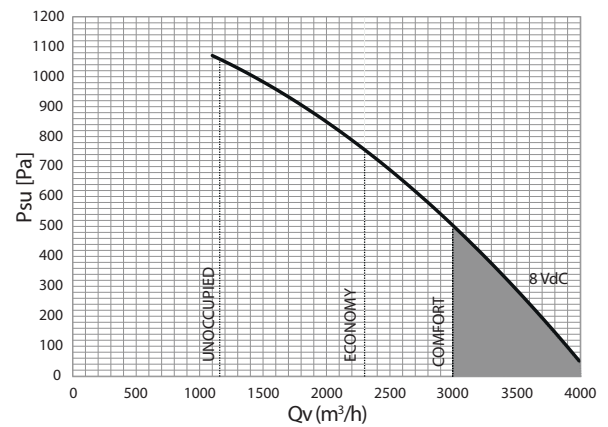

Psu = available static pressure  
Qv = Air flow rate

### ENY-PV5

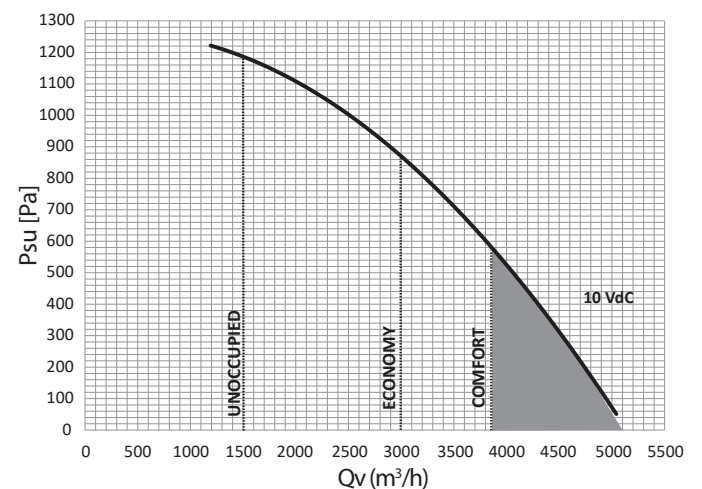

Psu = available static pressure  
Qv = Air flow rate

### » Unit with constant differential pressure control

The basic operating logic assumes that the system to which the unit is applied is equipped with control dampers that activate, choke or deactivate certain system sections and, consequently, change the flow rate required by the central unit during operation. These are multi-zone systems since the flow rate in each zone can be adjusted independently of the others.

Compared to single-zone systems, in multi-zone systems it is preferable that the central unit is able to respond to the pressure fluctuations due to the opening or closing of the system dampers, by modulating the provided flow rate according to the request and minimising the changes of the pressure itself.

The applied control logic is that of variable flow rate with maintenance of the constant differential pressure.

The ENY-PV units configured at constant differential pressure are able to modulate the flow rate according to the differential pressures measured at the ends of the unit nozzles.

Discrete preset factory settings are also available for constant differential pressure controlled units that can adapt to different cases where the pressure drops at the design flow rates are more or less high.

Differential pressure ECONOMY [Pa]	Differential pressure COMFORT [Pa]	Differential pressure UNOCCUPIED [Pa]
500	750	250

For units with constant differential pressure, the three ventilation modes must be understood as triple possibility of calibrating the machine in different engineering configurations that may occur.

In these cases, the unit must not be selected at an "Economy" flow rate, with respect to which temporary flow rate variations are allowed, but it must be selected based on its maximum flow rate that the subordinate damper system will adjust according to the needs of the individual zones, which may separately request flow rate attenuation rather than hyperventilation.

In order to modify the factory settings or differentiate them between the two flows, it is necessary to use the PC tool ENY-PV Manager.

The available control curves are shown below:

#### ENY-PV2

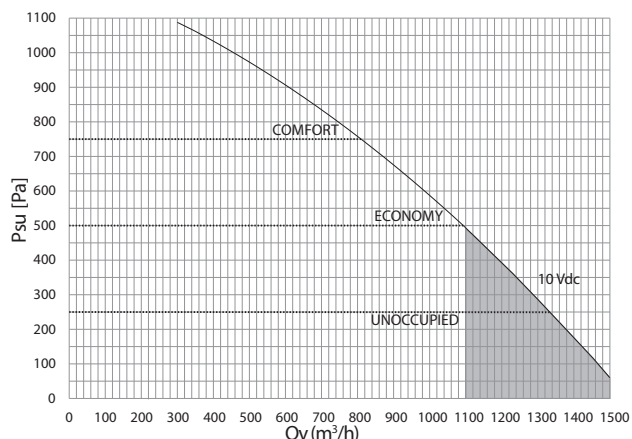

Psu = available static pressure  
Qv = Air flow rate

#### ENY-PV3

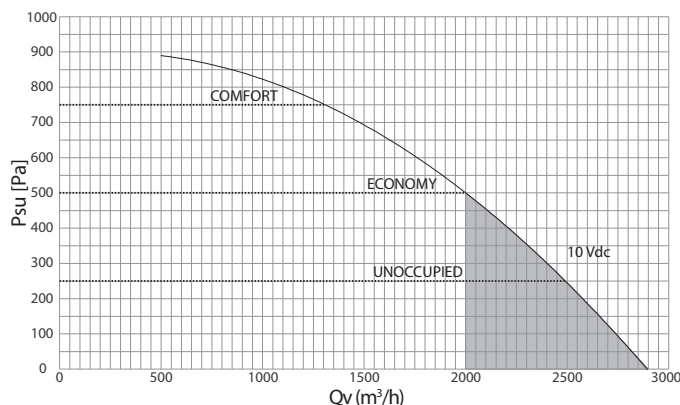

Psu = available static pressure  
Qv = Air flow rate

#### ENY-PV4

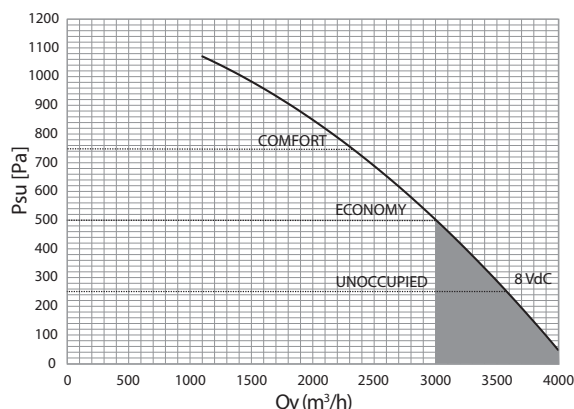

Psu = available static pressure  
Qv = Air flow rate

**ENY-PV5**

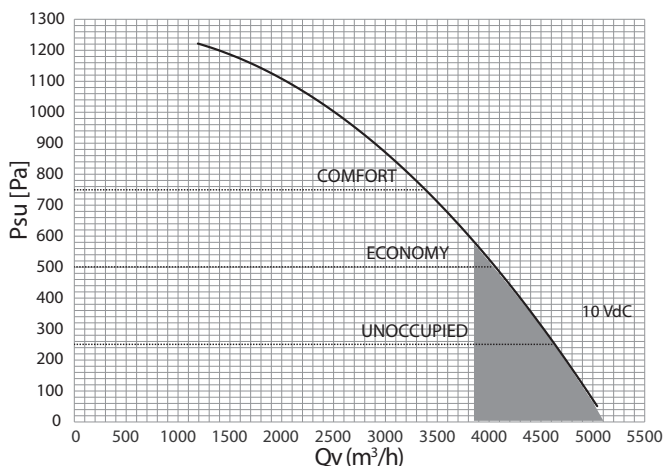

Psu = available static pressure  
 Qv = Air flow rate



**IMPORTANT! : Once the machine is powered, a few minutes are needed before the fans start.**

At the time of powering the machine, the main electronic board runs a start-up procedure for a few minutes and then the unit starts in AUTO mode with the following factory weekly program.

*Weekly program, Business Premises*

DAY	Monday - Sunday																							
TIME	0-1	1-2	2-3	3-4	4-5	5-6	6-7	7-8	8-9	9-10	10-11	11-12	12-13	13-14	14-15	15-16	16-17	17-18	18-19	19-20	20-21	21-22	22-23	23-24
SPEED																								
UNOCCUPIED																								
ECONOMY																								
COMFORT																								

It will, therefore, be necessary to perform the following operations using the PL-Link command, as described in the appropriate paragraph:

- Set the date and time
- Possibly modify the ventilation mode or define the desired weekly program.

If it is not possible to install the © Siemens **PL-Link** control in a place where it can be easily consulted, it is recommended to transfer the alarm signals to a remote control room, as described in the appropriate paragraph dedicated to auxiliary connectivity.

Should it be necessary to change the factory settings, perform an advanced modification of the factory configuration of the central electronic board.

## DESCRIPTION OF THE AUTOMATIC LOGICS INTEGRATED IN THE UNITS

The ENY-PV units are standard equipped with the following automatic control and sensor devices:

### » **SENSORS**

- 4 NTC temperature probes located respectively on the flows:
  - Fresh air outlet
  - Supply
  - Extraction from the occupied room
  - Exhaust
- Differential pressure switches for detecting the exceeding of the minimum fouling state in the filters which requires their replacement.
- Different pressure transducers for controlling the ventilation modes.

### » **SERVO-ASSISTED AUTOMATIC CONTROL SYSTEMS**

- Electronic plug-fans controlled with 0-10V analogue signal for controlling the target pressure or flow rate.
- 0-10V modulating actuator for controlling the opening and closing of the by-pass damper located on the counter flow heat exchanger.
- For units designed for colder climates, modulating electric heater controlled with 0-10V analogue signal for controlling the exhaust temperature in order to prevent the formation of ice in the exchanger.

The electronic control board is programmed with the following operating logics that use the sensor readings to actuate the servo assisted systems.

### » **MANAGING THE VENTILATION MODES**

The units can be factory set to control the fans with respect to two different operating logics.

**CONSTANT FLOW RATE CONTROL:** two differential static pressure transducers are applied to the fans between the upstream and downstream of their suction cones in order to measure the flow rate according to the inlet pressure drop and the flow coefficient characteristics of the suction geometry.

The electronic board runs an automatic PID control that regulates the speed of each fan to obtain and maintain the desired volumetric flow rate.

A target volumetric flow rate can be set for each of the ventilation modes.

This setting is recommended in commercial and auditorium applications where one wants to exchange the air of a single room with a single ventilation unit.

### • **CONSTANT DIFFERENTIAL PRESSURE CONTROL:**

Two differential static pressure transducers are applied between the upstream and downstream of the unit.

The system allows the electronic board to run an automatic PID control that regulates the speed of each fan to obtain and maintain the desired available static pressure at the ends of the unit. A target available static pressure can be set for each of the ventilation modes.

This setting is recommended in cases where the ventilation unit must serve a variety of different rooms through a branched network equipped with dedicated local control dampers.

In order for each room to be supplied with the desired flow rate, the pressure available to the individual junction damper must be kept as constant as possible.

The constant differential pressure control makes it possible to adapt fan flow rates according to the number of open dampers in order to obtain the desired flow rate in each room.

### » **BY-PASS DAMPER CONTROL**

The ENY-PV ventilation units are equipped with counter flow heat exchanger with 100% modulating by-pass damper.

The control logic of the by-pass damper aims to provide the room with an intake air flow as close as possible to neutral values with respect to the indoor temperature, in turn regulated by independent air conditioning systems. To ensure environmental comfort conditions, the target temperature is defined through a compensation curve according to the outdoor temperature. In this way, the colder the outdoor temperature, the higher the target intake temperature will be, allowing the unit to adapt to the natural demand of the occupants to increase heating.

Likewise, the higher the outdoor summer temperature, the higher the intake temperature that adapts to the natural trend of the occupants to wear less clothing.

The electronic control board constantly detects the need for heating or cooling the fresh air with respect to the indoor conditions and with respect to the desired target intake air temperature. Based on this detection and the target to be reached, the damper servo motor will be opened or closed, partially or totally, with the effect of controlling the full thermal recovery exchanger, to use the internal thermal resource or to directly use the external thermal resource (free-cooling or free-heating).

Therefore, free-cooling and free-heating are not indicated as specific operating modes but are naturally integrated into the by-pass damper control which uses the external thermal resource at any time convenient.

If, for example, the outdoor temperature ( $-10^{\circ}\text{C}$ ) is lower than the indoor temperature ( $22^{\circ}\text{C}$ ), the indoor temperature is higher than the input target ( $20^{\circ}\text{C}$ ) but the latter is higher than the outdoor one, then the resource to be used will be the indoor air and the by-pass damper will be commanded to close to use the thermal recovery exchanger in order to heat the intake flow. The higher the temperature target with respect to the extraction temperature (indoor), the more the damper will close and the thermal recovery will be total. Programming with compensation curve as the outdoor temperatures decrease makes it possible to make the most of thermal recovery in the winter season.

If the outdoor temperature ( $22^{\circ}\text{C}$ ) is lower than the indoor temperature ( $26^{\circ}\text{C}$ ), the indoor temperature is higher than the input target ( $20^{\circ}\text{C}$ ) but the latter is lower than the outdoor one, then using the recovery will be counterproductive and the resource to be used will be the outdoor one: the by-pass damper will be commanded to open to use the direct cooling capacity of the outdoor air flow (free-cooling).

#### » **FREEZING RISK MANAGEMENT**

If the outdoor temperatures are particularly cold and the internal humidity rises above the external dew point, not only will condensate form inside the exchanger in the exhaust quadrant, but there will also be the risk of freezing.

Freezing of the exchanger can cause undesired stresses on the plates and consequent breakages that would compromise operation and lead to a possible contamination between the flows.

It can also compromise the correct operation of the thermal recovery exchange.

Therefore, it is important and necessary to foresee certain actions in order to avoid this possibility, depending on whether the outdoor climate is more or less cold.

In case of particularly cold climates, with minimum outdoor temperatures below  $-10^{\circ}\text{C}$ , we recommend using units with internal antifreeze electric heater, otherwise it is possible to use the units without heater, in any case in compliance with the specified installation requirements.

#### » **UNITS WITH INTERNAL ELECTRIC HEATER**

The following table describes the control logic of the internal electric heater.

	Fresh air $t_1$	Exhaust air $t_4$
Switch on in continuous modulation antifreeze electric resistance	$t_1 > 0^{\circ}\text{C}$	Setpoint $5^{\circ}\text{C}$
	$-15^{\circ}\text{C} < t_1 < 0^{\circ}\text{C}$	Setpoint varies linearly from $5^{\circ}\text{C}$ to $7^{\circ}\text{C}$

The electric heater starts working only when the outdoor temperatures can cause the exchanger to freeze. For extremely cold climates, the electric heater setpoint is increased to further reduce the risk of damage.

#### » **MACHINES WITHOUT INTERNAL ELECTRIC HEATER**

##### **Constant flow rate machine**

The following table describes the control logic in the absence of internal electric heater.

	Exhaust air $t_4$
Supply= 70% of the Economy mode default flow rate Extraction= Economy mode default flow rate	Activation $t_4 < 3^{\circ}\text{C}$  Setpoint $t_4 = 3^{\circ}\text{C}$

To reduce the risk of freezing in the absence of integrated antifreeze systems, the fan flow rates are modified for the time necessary to reach the target exhaust temperature.

There is a general alarm condition, valid for all units, according to which the unit is stopped if the supply temperature drops below  $10^{\circ}\text{C}$ .

##### **Constant differential pressure machine**

The following table describes the control logic in the absence of internal electric heater.

	Exhaust air $t_4$
By-pass damper open by 30%	Activation $t_4 < 3^{\circ}\text{C}$ Setpoint $t_4 = 3^{\circ}\text{C}$  minimum duration of defrost cycle 3 minutes

In case of constant differential pressure machines, the target flow rate is defined by the local demand of the various control dampers. It is, therefore, not possible to apply antifreeze logics based on the variation of the supplied flow rate. For this reason one acts on the by-pass damper.

In case of particularly cold outdoor temperatures, using the by-pass damper can cause discomfort. In these cases, it is strongly recommended to select machines with active antifreeze protection systems.

### » **OPERATION IN CASE OF ADDITION OF AIR QUALITY SENSORS**

The air quality sensors that can be connected to the ventilation units are:

- Relative humidity sensor
- CO2 concentration sensor

No accessories specifically dedicated to the ventilation units are supplied.

The basic requirements for separately purchased sensors are:

- 0-10V Sensor analogue output signal
- Humidity sensors: scale 0-100%
- CO2 sensors: scale 0-2000 ppm

The ventilation units are not factory set to be able to receive the signal coming from an air quality probe. To this end, it is necessary to make the suitable integration to the electronic board configuration with the pc-tool **ENY-PV MANAGER**.

### » **ADDITION OF A HUMIDITY SENSOR**

It is possible to connect a relative humidity sensor to the unit (positioned in the extraction duct or inside a room). A humidity limit value can be defined for each of the ventilation modes (Comfort, Economy and Unoccupied).

If the relative humidity exceeds the set limit, the target flow rate of the fans is increased by means of a PI type control. In any case, the target pressure is limited to the maximum value of the Comfort ventilation mode.

The Boost mode has priority over the humidity control; therefore, it is not affected by the PI control. In the same way, the Comfort mode does not foresee changing the target flow rate.

Since a ventilation increase alone does not reduce the level of humidity in every situation, the dew temperature is used to define whether the fresh air conditions are such as to ensure a reduction in the room humidity.

If the fresh air temperature is low enough to ensure dehumidification, the PI control is activated. Otherwise, the PI control is only activated when favourable conditions are met.

If the humidity sensor is present, the automatic control starts working in background without having to activate a dedicated operating mode. There is no logic with the purpose of humidification but only dehumidification. Therefore, no reduction is foreseen for the fan speed aimed at increasing internal humidity.

The units are NOT able, by themselves, to lower the level of internal humidity to a value below that of the outdoor humidity.

### » **ADDITION OF A CO2 CONCENTRATION SENSOR**

It is possible to connect a CO2 sensor to the unit (positioned in the extraction duct or inside a room). A concentration limit value, expressed in ppm (CO2), can be defined for each of the ventilation modes (Comfort, Economy and Unoccupied).

If the concentration exceeds the set limit, the target flow rate of the fans is increased by means of a PI type control. In any case, the target flow rate is limited to the maximum value of the Comfort ventilation mode.

The Boost mode has priority over the automatic control; therefore, it is not affected by the PI control. In the same way, the Comfort mode does not foresee changing the target flow rate.

If the target flow rate increase is not enough to reach the set setpoint, the PI control further increases the supply flow rate favouring air oxygenation.

If the CO2 sensor is present, the automatic control starts working in background without having to activate a dedicated operating mode.

### » **RH AND CO2 COINCIDENCE**

If both sensors, CO2 and RH, are configured, both automatic fan control modes are active.

The two modes have different set points and thus different control logics.

Therefore, the fans are controlled according to the highest control signal, i.e. the one corresponding to a higher fan speed.

In this way, the air quality conditions are in any case met.

### » **AIR QUALITY SENSORS FOR CONSTANT DIFFERENTIAL PRESSURE MACHINES**

In case of constant differential pressure machines, the air quality control is entrusted to the local room systems. The central unit does not regulate the flow rate provided to the system, but adapts to the demand of the control dampers. Therefore, in the event constant differential pressure machines are used, the logics related to the air quality sensors are disabled.

## ROUTINE MAINTENANCE



It is advisable to carry out a PREVENTIVE MAINTENANCE on the unit in order to keep it efficient over time.

These units require little maintenance and have been designed to make every operation as easy and safe as possible.

The maintenance interventions must only be carried out by the installer or by qualified staff.

The following paragraphs have a short description of the maintenance interventions.

**NOTE: If maintenance is not carried out regularly, the ventilation system might not work properly.**

At each maintenance intervention, check the tightening torque of the connection screws of power supply cables and connection cables.

### » Inspection panel opening



**Always disconnect power from the main panel. Disconnect the power supply from the C1 Circuit breaker (if machine with internal electric heater, circuit breakers C1 and C2) setting it to OFF, before accessing the machine.**

In order to access the inside of the unit, it is necessary to open the inspection panels, which are equipped with handles with integrated safety locks.

Use the square cylinder key (1) provided to open the handles (2) and unlock the inspection panels.

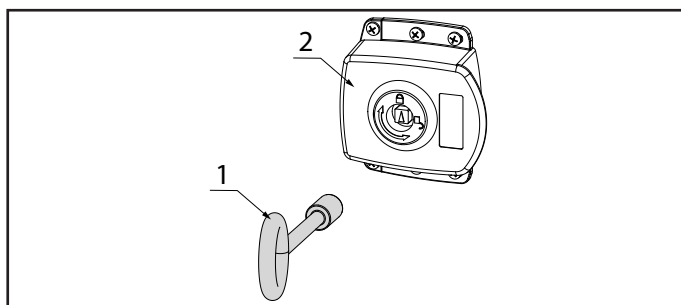

### • Lock detail

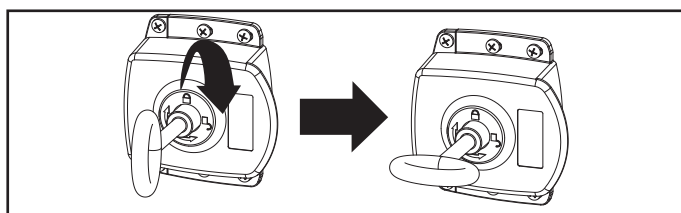
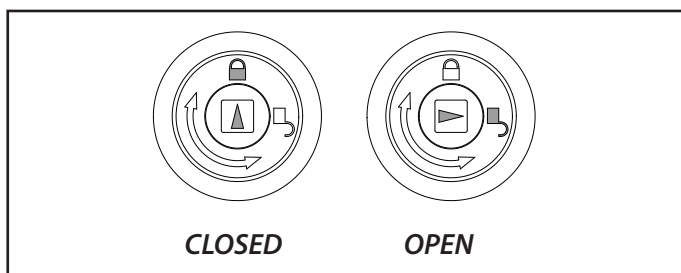

Unit view with the inspection panels open

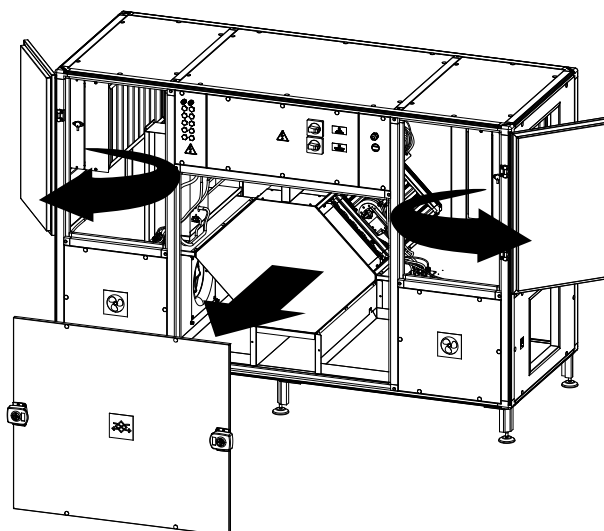

### » Parts subject to maintenance

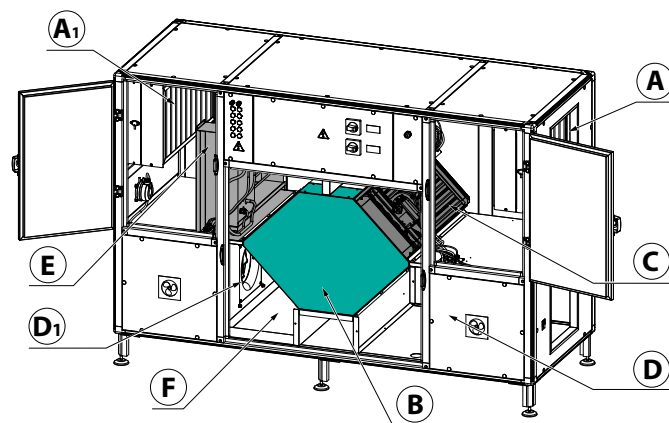

#### • FILTERS (A-A1)

Examine the filters every three months and, in the event of a signal by the control, proceed with the replacement;

#### • EXCHANGER (B)

Inspect the heat exchanger and clean it if necessary;

#### • DAMPER (C)

Inspect the damper and clean it, if necessary;

#### • FANS (D-D1)

Inspect the fans and clean them, if necessary;

#### • ELECTRIC HEATER (E)

Examine the electric heater and (if necessary), proceed with cleaning (valid for machines equipped with internal electric heater);

#### • CONDENSATE COLLECTION TRAY AND DRAIN (F)

Check the condensate tray and drain and, if necessary, proceed with cleaning.

#### • PNEUMATIC PIPES (see the paragraph "Pneumatic Connections")

Inspect the pipes and clean them, if necessary

### » **Filters (A-A1)**

The parts are the ones that most require frequent maintenance in order to:

- Maintain filtered air in the room with the desired efficiency.
- Prevent damaging the components inside the unit.

Examine the filters every three months to check their status.

The filters must be replaced when the type "2" alarm signal appears with the wording "1020" on the PL Link control panel. The signal occurs when a 160 Pa pressure difference on the filters is exceeded.

Follow the instructions given in the PL Link paragraph to reset the alarm and restore the function after replacing the filters.

The unit cannot be used without filters.

- Open the inspection doors;
- Remove the stop;
- Extract the filters and replace them;
- Pay attention to any dividing cover between the filtration modules (unit sizes 3, 4 and 5)
- Put all the components back in place, in the opposite order and reconnect the power.

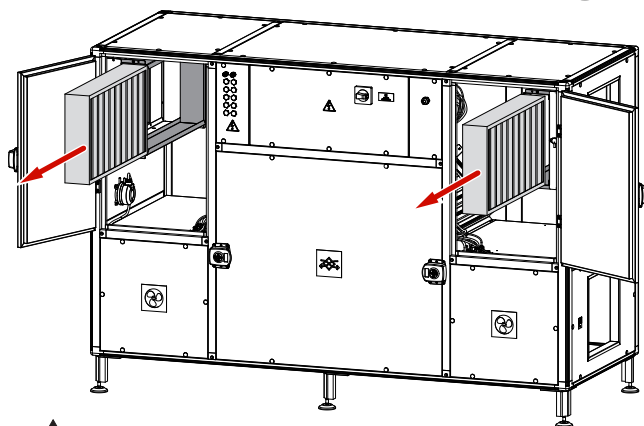
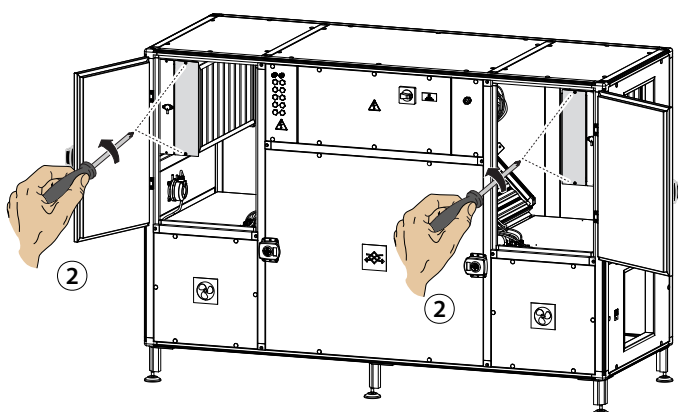

**IMPORTANT!: follow the codes on the filters.**

**Mount the filters so that the arrow on the front of the filter is consistent with the direction of the flow. Operation of the unit is ensured only if original spare parts are used.**

### » **Heat exchanger (B)**



**Always disconnect power from the main panel. Disconnect the power supply from the C1 Circuit breaker (if machine with internal electric heater, circuit breakers C1 and C2) setting it to OFF, before accessing the machine.**

Recommended cleaning frequency: **ANNUAL**

As there are no mobile parts, the maintenance of this type of recovery unit is limited to cleaning.

For normal ventilation applications, it is sufficient to clean the inlet and outlet with a brush or water and, if necessary, a neutral detergent.

If there is a lot of dirt, you may use compressed air or wash with water, as long as at a washing pressure of no more than 2 or 3 bar.

Remember not to aim high pressure jets directly at the plates.

Use a soft brush to clean the fins.

Use a vacuum cleaner or compressor (not high pressure) to remove debris and dust.

**IMPORTANT!: Always clean in the opposite direction of the air flow (see the paragraph "Ductwork Connections").**

### » **Damper (C)**

Recommended cleaning frequency: **ANNUAL**

The control damper does not require any particular maintenance.

However, it is advisable to check the alignment of the control levers and the opening and closing movement of the flaps.

Use a brush to clean the flaps.

Use a vacuum cleaner to remove dirt and dust.

Lever lubrication.

### » **Fans (D)**

Recommended cleaning frequency: **ANNUAL**

In order to maintain the performance and operating conditions of the fans optimal, it is advisable to clean the auger and fan by removing any residues/deposits using a soft brush, and a vacuum cleaner to remove the dust.

**CAUTION!: DO NOT DAMAGE THE FAN BLADES.**

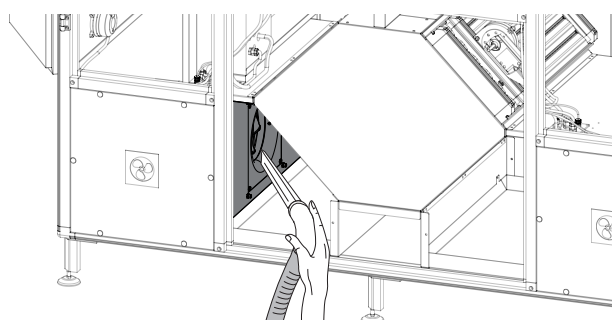

» **Internal electric heater (E) (if any)**



**Always disconnect power from the main panel. Disconnect the power supply from the “C1” and “C2” Circuit breakers by setting them to OFF, before accessing the machine.**

**Caution! Hot surfaces**



Recommended cleaning frequency: **ANNUAL**

In order to maintain the performance and operating conditions of the heater optimal, it is advisable to remove any residues/deposits using a vacuum cleaner.

» **Condensate drain and tray (F)**

Recommended cleaning frequency: **ANNUAL**

In order to maintain the operating conditions optimal, it is advisable to remove any residues/deposits.

The condensate collection tray must be washed with water and neutral soap and a brush.

It is important to check that the drain fitting is clean and not obstructed by objects, dust or other.

If necessary, use a pipe cleaner to remove any residues.

Before starting any maintenance, always make sure that the unit is disconnected from the mains.

» **Pneumatic pipes (see the paragraph “Pneumatic Connections”)**

Recommended cleaning frequency: **ANNUAL**

In order to ensure the correct operation of the units and control logics of the fans, it is advisable to check for residues/deposits or humidity inside the pneumatic pipes. If so, replace the pneumatic pipes.

**CAUTION!:** Do not use compressed air to clean the pipes if either end is connected to the machine. The pressurised air would irreversibly damage the sensors.







Oggetto: **Dichiarazione di conformità UE**  
Object: **EU Declaration of conformity**

**La presente dichiarazione di conformità è rilasciata sotto la responsabilità esclusiva del fabbricante.**  
**This declaration of conformity is issued under the exclusive responsibility of the manufacturer.**

**Prodotto:** Energy Plus V - Recuperatori di Calore  
**Product:** Energy Plus V - Recovery Units

**Modello / Pattern:** ENY-PV2QL, ENY-PV3QL, ENY-PV4QL, ENY-PV5QL,  
ENY-PV2QR, ENY-PV3QR, ENY-PV4QR, ENY-PV5QR,  
ENY-PV2QEL, ENY-PV3QEL, ENY-PV4QEL, ENY-PV5QEL,  
ENY-PV2QER, ENY-PV3QER, ENY-PV4QER, ENY-PV5QER,  
ENY-PV2DPL, ENY-PV3DPL, ENY-PV4DPL, ENY-PV5DPL,  
ENY-PV2DPR, ENY-PV3DPR, ENY-PV4DPR, ENY-PV5DPR,  
ENY-PV2DPEL, ENY-PV3DPEL, ENY-PV4DPEL, ENY-PV5DPEL,  
ENY-PV2DPER, ENY-PV3DPER, ENY-PV4DPER, ENY-PV5DPER

**al quale questa dichiarazione si riferisce, è conforme alle seguenti norme:**  
**to which this declaration relates is in conformity with the following standards or other normative document(s):**

EN 60335-1 (2012) + A11 (2014)  
EN 60335-2-80 (2003) + A1 (2004) + A2 (2009)  
EN 55014-1 (2006) +A1 (2009) + A2 (2011)  
EN 55014-2 (2015)  
EN 61000-3-2 (2014)  
EN 61000-3-3 (2013)  
EN 50581 (2012)  
Reg. N. 327/2011  
Regulation (UE) 1253/14

**L'oggetto della dichiarazione di cui sopra è conforme alla pertinente normativa di armonizzazione dell'Unione.**  
**The object of the declaration described above is in conformity with the relevant Union harmonization legislation.**  
**2014/35/UE 2014/30/UE 2006/42/EC 2011/65/UE 2009/125/EC**

Il fascicolo tecnico è costituito presso: Sabiana S.p.A. Via Piave 53, 20011 Corbetta (MILANO-ITALY)  
The technical file is made at: Sabiana S.p.A. Via Piave 53, 20011 Corbetta (MILANO-ITALY)

Corbetta, 26/02/2021

Nicola Binaghi  
Presidente

