

Low Noise Fan Coil



TEC Fan Coil Units

CONTENTS

• Construction	<i>Page 4</i>
• Models	<i>Page 5</i>
• Dimension, Weight, Water content	<i>Page 6</i>
• Technical features	<i>Page 10</i>
• Operation limits	<i>Page 13</i>
• Emission tables	<i>Page 14</i>
• Correction factors table	<i>Page 24</i>
• Water pressure drop	<i>Page 25</i>
• Accessories	<i>Page 26</i>
• Controls	<i>Page 45</i>
• Controls and units MB version	<i>Page 54</i>
• Management system for a network of fan coils	<i>Page 59</i>
• PSM-DI and NET electronic boards	<i>Page 63</i>

In line with innovative trends and modern industrial design, the **TEC** fan coil range meets today's demanding requirements of performance, size, acoustics, low energy, ease of installation and maintenance. The **TEC** fan coil unit has been designed around a platform of models, versions and accessories.

Designed around 5 different versions, the extensive range includes wall and ceiling mounted units, exposed or concealed with centrifugal fan, delivering one of the most versatile ranges of fan coils on the market today.

All **TEC** fan coils with centrifugal fans are equipped with electric motors which dramatically reduce electrical consumption of up to 40% comparative to previous models, with 6 speed motors as standard offering greater flexibility in the selection of products.

New market trends have also led to an extension of the four pipe model which now has a two row LTHW coil giving improved outputs at lower flow and return temperatures.

A full range of adjustment and control devices is available for rapidly obtaining correct environmental temperature and with an investment proportional to performances, comfort and desired measurement precision.

The **TEC** model is complemented with a full range of accessories: various types of adjustment valves, sturdy support feet, rear covering panel for glass installation, additional electric heater, auxiliary condensate pump, fresh air intake louver, air inlet/outlet diffusers for fitted installations.



TEC version with centrifugal fan

Range includes 9 air flow rates (from 105 to 1500 m³/h) and 5 models (for wall and ceiling installation, with casing and concealed), each equipped with 3 or 4 row coil and with the possibility to add a 1 or 2 row coil for 4 pipe systems.

It is the most comprehensive range, perfectly suited to meet all of the climate control needs of work environments such as offices, shops, restaurants and hotel rooms featuring ducted installations with available pressure up to 50 Pa.

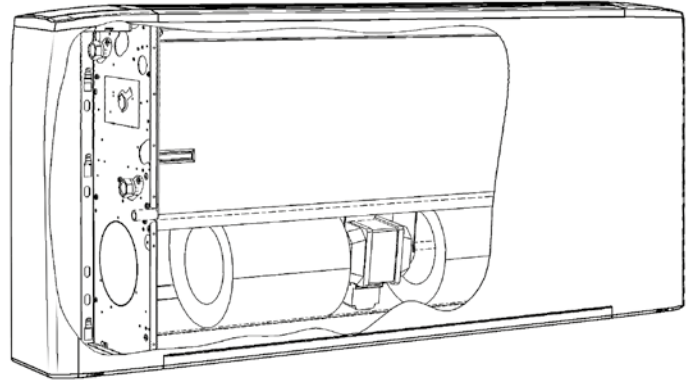

Plastic outlet grid in one single piece: extraordinary design and strength



Construction

Outer casing

Made of galvanized and pre-painted steel casing.

The plastic top grid has fixed louvres and is reversible in order to distribute the air in two different directions.

Standard colours:

- Top grid: **Pantone 427C (light grey)**

- Casing: **RAL 9003 (white)**
- Other colours on request.

Inner casing

Made from 1 mm galvanized steel insulated with 3 mm polyolefin (PO) foam (class M1).

Filter

Polypropylene cellular fabric regenerating filter.

The filter frame of galvanized steel is inserted into special plastic sliding guides fastened to the internal structure for easy insertion and removal of the filter.

Filter presence is highlighted by a plastic front cover featuring the same colour as the top grid.



Fan assembly

The fans have aluminium or plastic blades directly keyed on the motor with double aspiration and they are dynamically and statically balanced during manufacture in order to have an extremely quiet operation.

Electric motor

The motor is wired for single phase and has six speeds, three of which are connected, with capacitor.

The motor is fitted on sealed for life bearings and is secured on anti-vibration and self-lubricating mountings.

Internal thermal protection with automatic reset, protection IP 20, class B.

The speeds connected in the factory are indicated by "MIN, MED and MAX" in the following tables.

Coil

It is manufactured from drawn copper tube and the aluminium fins are mechanically bonded onto the tube by an expansion process. The coil has two 1/2inch BSP internal connections and 1/8 inch BSP air vent and drain.

The coil is not suitable for use in corrosive atmosphere or in environments where aluminium may be subject to corrosion.

The connections are on the left hand side facing the unit. On request we can deliver the unit with the connections on the right end side. This operation can also be easily carried out on site during installation.

Condensate collection tray

Made from plastic (ABS UL94 HB) with an "L"-shaped plastic fitted on the inner casing; in the CVB-CH and NC model the tray is insulated with 3 mm polyolefin (PO) foam (class M1). The outside diameter of the condensate discharge pipe is 15mm.

Accessories and Controls

See pages 26 - 43.

Models

CV

Vertical Casing – Wall Installation

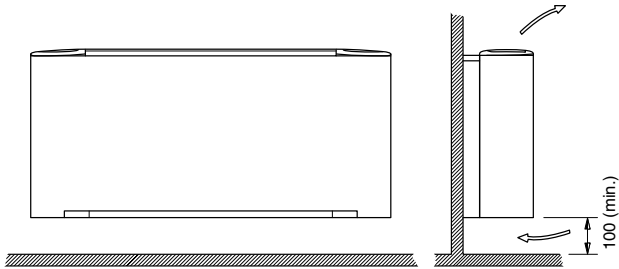

CV

Vertical Casing – Ceiling Installation

NOTE: the CV model can also be installed horizontally leaving behind a 100 mm gap for air intake.

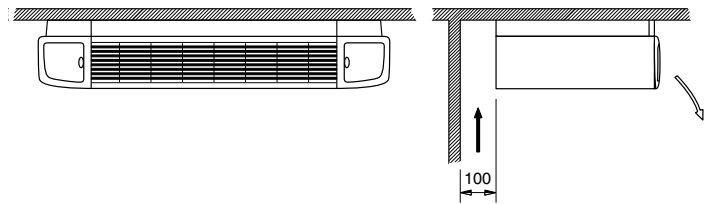

CVB

Vertical Casing – Floor Installation

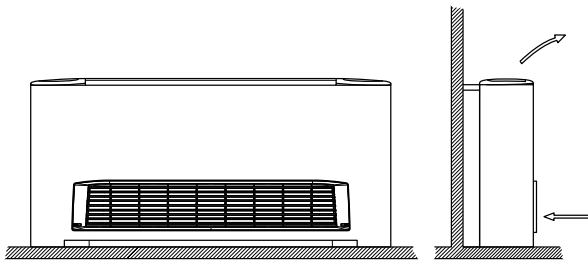

CH

Horizontal Casing

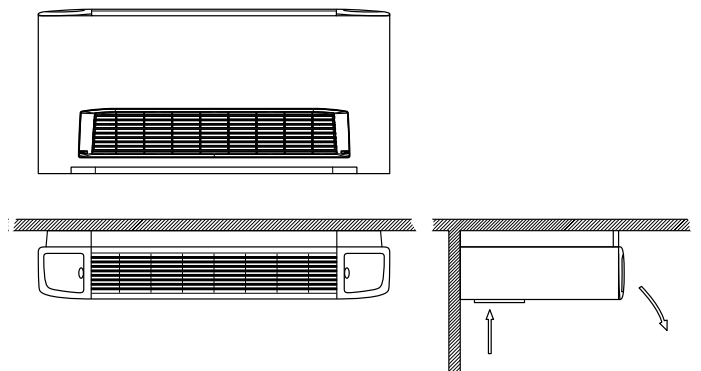

NC

Vertical Concealed

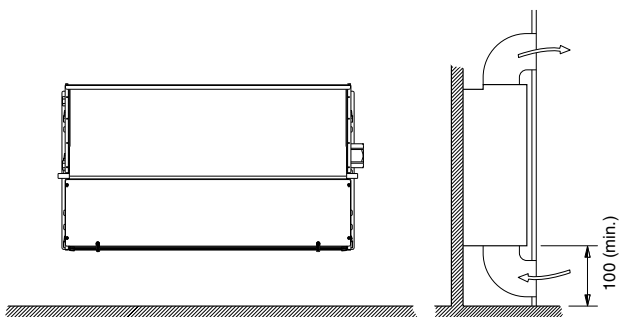

NC

Horizontal Concealed

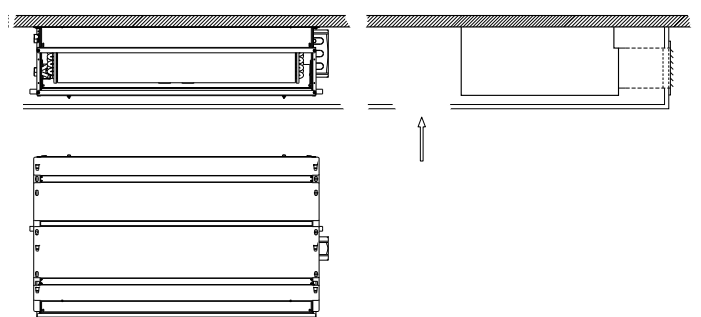

TEC version

Dimension, Weight, Water content

CV

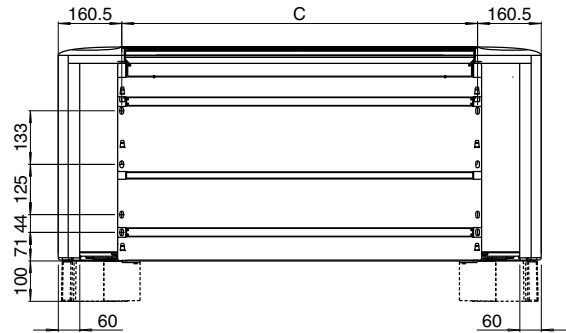
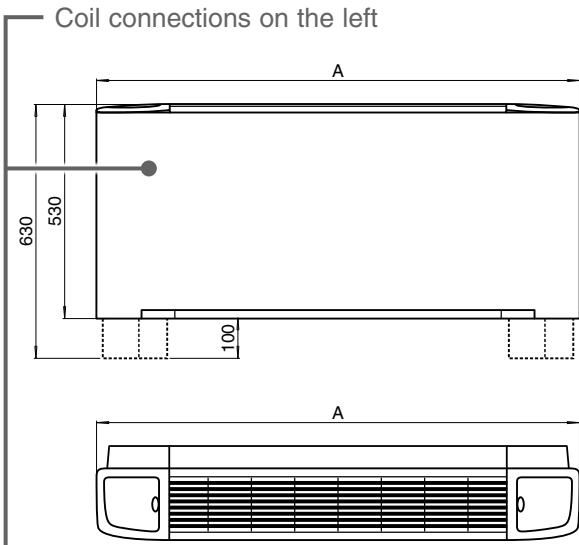

Feet (optional)

CH-CVB

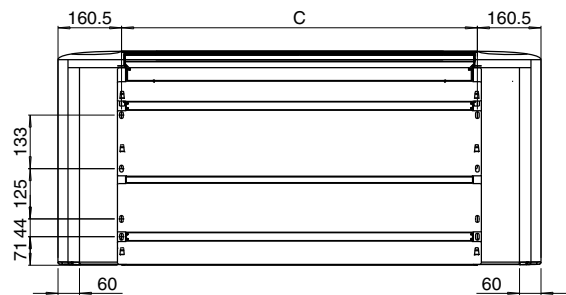
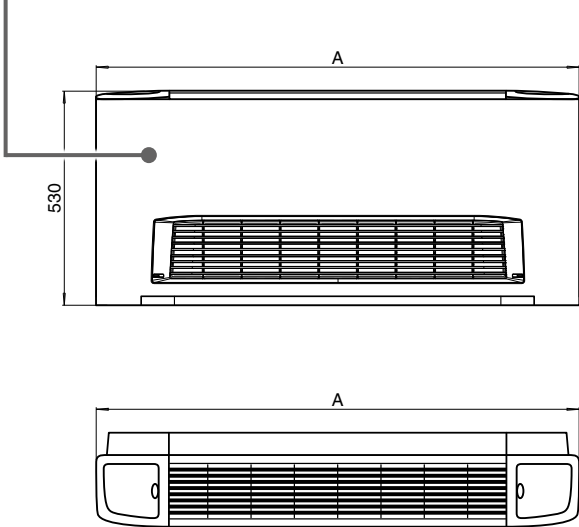

COIL CONNECTIONS

3 or 4 row coils

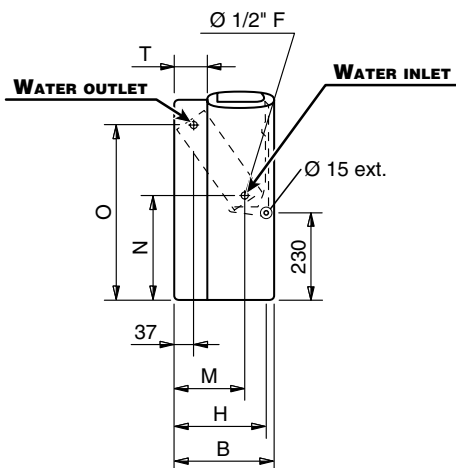

Heating additional coil (1 or 2 rows)

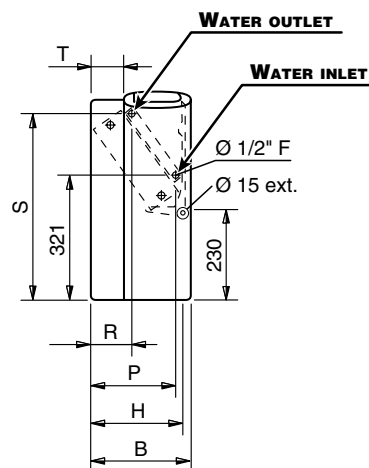

Dimension, Weight, Water content

PACKAGING

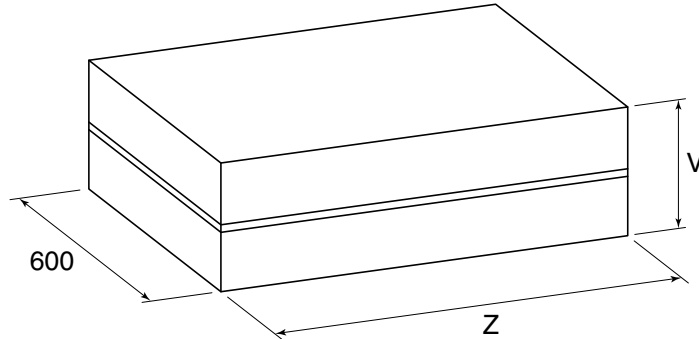

Dimension (mm)

MODELLO	1	2	3	4	5	6	7	8	9
A	675	775	990	990	1205	1205	1420	1420	1420
B	225	225	225	225	225	225	225	255	255
C	354	454	669	669	884	884	1099	1099	1099
H	205	205	205	205	205	205	205	235	235
M	145	145	145	145	145	145	145	170	170
N	260	260	260	260	260	260	260	270	270
O	460	460	460	460	460	460	460	450	450
P	185	185	185	185	185	185	185	210	210
R	105	105	105	105	105	105	105	110	110
S	475	475	475	475	475	475	475	465	465
T	55	55	55	55	55	55	55	85	85
V	260	260	260	260	260	260	260	290	290
Z	720	820	1035	1035	1250	1250	1465	1465	1465

Weight (kg)

		Weight with packaging									Weight without packaging								
MODEL		1	2	3	4	5	6	7	8	9	1	2	3	4	5	6	7	8	9
Rows	3	15,5	17,2	21,4	22,5	26,9	27,7	32,1	35,7	35,9	13,9	15,4	19,1	20,2	24,1	24,9	28,8	32,0	32,2
	3+1	16,2	18,0	22,6	23,7	28,4	29,2	33,9	37,5	37,7	14,6	16,2	20,3	21,4	25,6	26,4	30,6	33,8	34,0
	3+2	16,7	18,6	23,3	24,4	29,3	30,1	35,0	38,6	38,8	15,1	16,8	21,0	22,1	26,5	27,3	31,7	34,9	35,1
	4	16,0	18,0	22,4	23,5	28,1	29,0	33,6	37,2	37,4	14,4	16,2	20,1	21,2	25,3	26,2	30,3	33,5	33,7
	4+1	16,7	18,8	23,6	24,7	29,6	30,5	35,4	39,0	39,2	15,1	17,0	21,3	22,4	26,8	27,7	32,1	35,3	35,5

Water content (litres)

MODEL	1	2	3	4	5	6	7	8	9
Rows	3	0,5	0,6	0,9	0,9	1,3	1,6	1,7	1,9
	4	0,7	0,8	1,3	1,3	1,7	2,2	2,4	2,8
	+1	0,2	0,2	0,3	0,3	0,4	0,5	0,5	0,6
	+2	0,4	0,4	0,6	0,6	0,8	1,0	1,0	1,2

Dimension, Weight, Water content

NC Vertical Installation

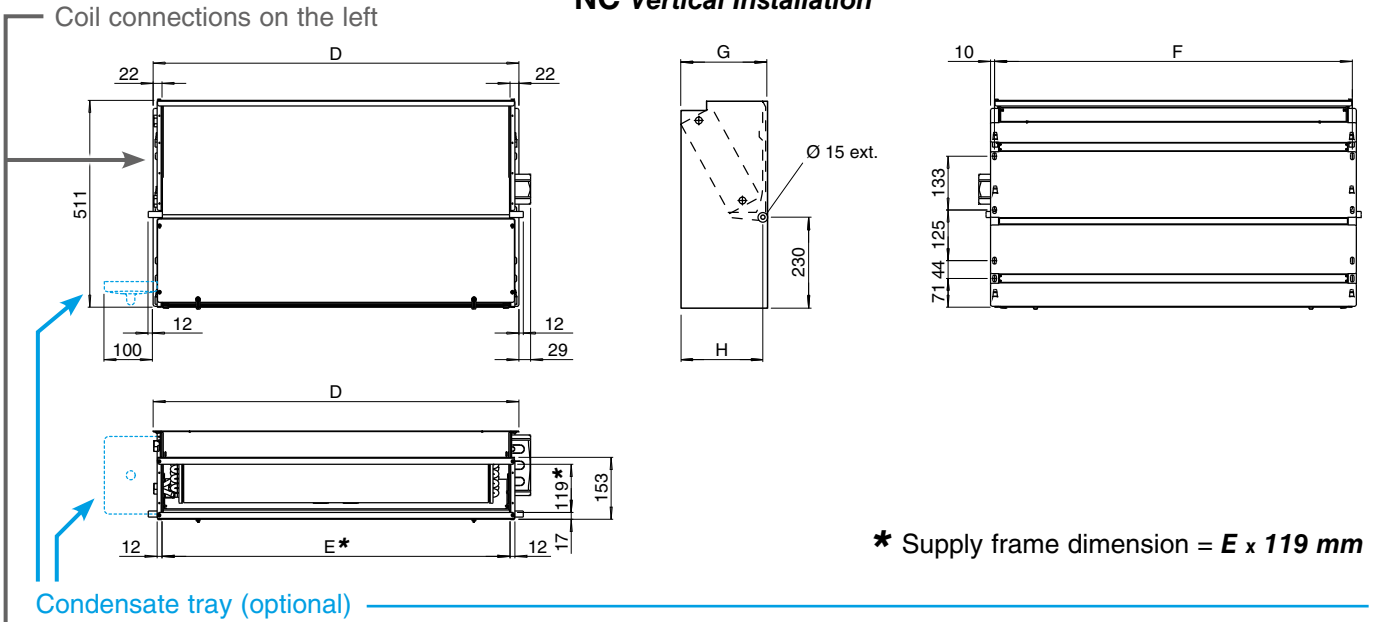

NC Horizontal Installation

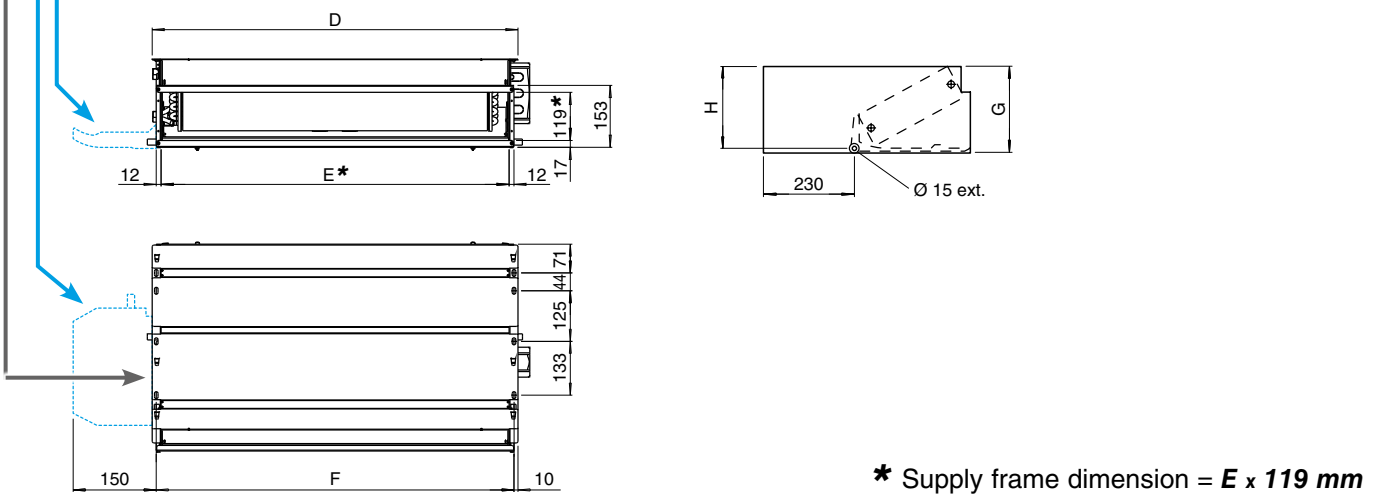

COIL CONNECTIONS

3 or 4 row coils

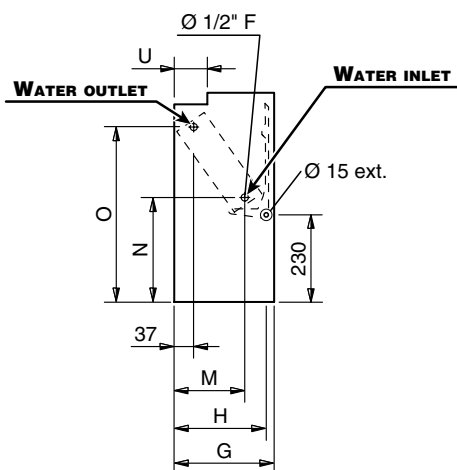

Heating additional coil (1 or 2 rows)

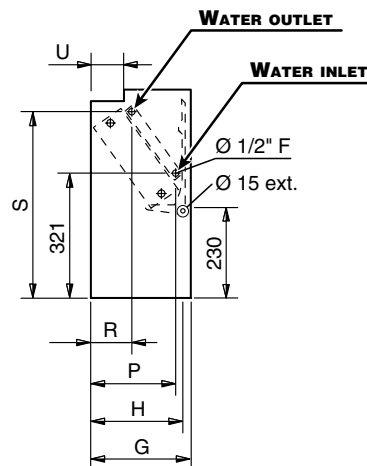

Dimension, Weight, Water content

PACKAGING

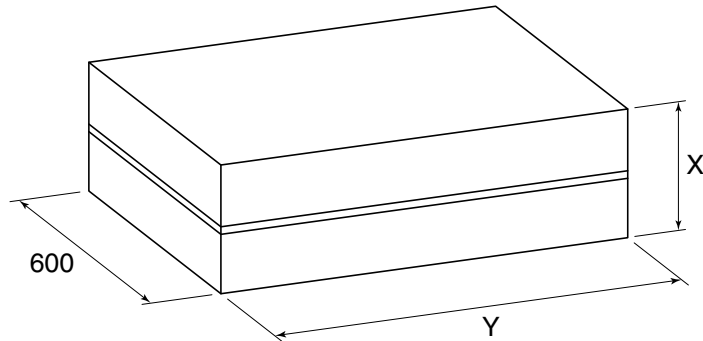

Dimension (mm)

MODEL	1	2	3	4	5	6	7	8	9
D	374	474	689	689	904	904	1119	1119	1119
E	330	430	645	645	860	860	1075	1075	1075
F	354	454	669	669	884	884	1099	1099	1099
G	218	218	218	218	218	218	218	248	248
H	205	205	205	205	205	205	205	235	235
M	145	145	145	145	145	145	145	170	170
N	260	260	260	260	260	260	260	270	270
O	460	460	460	460	460	460	460	450	450
P	185	185	185	185	185	185	185	210	210
R	105	105	105	105	105	105	105	110	110
S	475	475	475	475	475	475	475	465	465
U	65	65	65	65	65	65	65	95	95
X	260	260	260	260	260	260	260	290	290
Y	720	820	820	820	1035	1035	1250	1250	1250

Weight (kg)

		Weight with packaging									Weight without packaging								
MODEL		1	2	3	4	5	6	7	8	9	1	2	3	4	5	6	7	8	9
Rows	3	12,2	13,6	17,1	18,1	21,9	22,8	27,0	30,2	30,4	10,6	11,8	15,3	16,3	19,6	20,5	24,2	27,1	27,3
	3+1	12,9	14,4	18,3	19,3	23,4	24,3	28,8	32,0	32,2	11,3	12,6	16,5	17,5	21,1	22,0	26,0	28,9	29,1
	3+2	13,4	15,0	19,0	20,0	24,3	25,2	29,9	33,1	33,3	11,8	13,2	17,2	18,2	22,0	22,9	27,1	30,0	30,2
	4	12,7	14,4	18,1	19,1	23,1	24,1	28,5	31,7	31,9	11,1	12,6	16,3	17,3	20,8	21,8	25,7	28,6	28,8
	4+1	13,4	15,2	19,3	20,3	24,6	25,6	30,3	33,5	33,7	11,8	13,4	17,5	18,5	22,3	23,3	27,5	30,4	30,6

Water content (litres)

MODEL		1	2	3	4	5	6	7	8	9
Rows	3	0,5	0,6	0,9	0,9	1,3	1,6	1,7	1,9	1,9
	4	0,7	0,8	1,3	1,3	1,7	2,2	2,4	2,8	2,8
	+1	0,2	0,2	0,3	0,3	0,4	0,5	0,5	0,6	0,6
	+2	0,4	0,4	0,6	0,6	0,8	1,0	1,0	1,2	1,2

Technical features

TEC UNITS WITH 3 ROW COIL

2 pipe units.

The following standard rating conditions are used:

COOLING

Entering air temperature +27°C d.b. +19°C w.b.
Water temperature +7°C E.W.T. +12°C L.W.T.

HEATING

Entering air temperature +20°C
Water temperature +45°C E.W.T. +40°C L.W.T.

MODEL		TEC 1.3-2T						TEC 2.3-2T						TEC 3.3-2T					
		1	2	3	4	5	6	1	2	3	4	5	6	1	2	3	4	5	6
Speed		MIN		MED		MAX		MIN		MED		MAX		MIN		MED		MAX	
Air flow	m³/h	105	125	150	175	195	220	145	170	220	250	295	340	185	235	270	325	385	440
Cooling total emission	kW	0,57	0,66	0,75	0,84	0,91	1,00	0,90	0,99	1,23	1,35	1,53	1,70	1,27	1,55	1,76	2,04	2,35	2,61
Cooling sensible emission	kW	0,45	0,53	0,60	0,69	0,75	0,83	0,68	0,76	0,95	1,06	1,21	1,36	0,92	1,13	1,30	1,51	1,76	1,97
Heating	kW	0,64	0,76	0,86	0,98	1,07	1,19	0,94	1,06	1,34	1,49	1,70	1,92	1,26	1,56	1,79	2,10	2,44	2,74
Dp Cooling	kPa	2,5	3,0	3,8	4,7	5,4	6,3	2,5	3,0	4,4	5,3	6,5	7,9	6,6	9,4	11,8	15,3	19,7	23,8
Dp Heating	kPa	0,9	1,1	1,4	1,8	2,1	2,5	2,2	2,8	4,2	5,0	6,4	7,9	5,4	7,8	10,0	13,2	17,1	21,0
Fan	W	16	19	21	25	29	33	14	16	22	26	32	40	15	20	25	32	41	49
Sound power	Lw dB(A)	32	34	36	39	42	45	30	33	40	43	47	51	31	36	40	45	49	52
Sound pressure (*)	Lp dB(A)	23	25	27	30	33	36	21	24	31	34	38	42	22	27	31	36	40	43

MODEL		TEC 4.3-2T						TEC 5.3-2T						TEC 6.3-2T					
		1	2	3	4	5	6	1	2	3	4	5	6	1	2	3	4	5	6
Speed		MIN		MED		MAX		MIN		MED		MAX		MIN		MED		MAX	
Air flow	m³/h	185	265	335	400	485	570	250	315	420	495	545	650	415	505	590	680	760	830
Cooling total emission	kW	1,25	1,71	2,11	2,43	2,83	3,19	1,66	2,01	2,55	2,90	3,13	3,58	2,50	2,94	3,32	3,70	4,01	4,26
Cooling sensible emission	kW	0,91	1,26	1,57	1,82	2,15	2,45	1,22	1,49	1,91	2,19	2,38	2,76	1,87	2,23	2,54	2,86	3,12	3,35
Heating	kW	1,25	1,74	2,18	2,52	2,97	3,41	1,65	2,02	2,61	3,00	3,24	3,75	2,56	3,05	3,45	3,90	4,26	4,56
Dp Cooling	kPa	6,5	11,2	16,2	20,8	27,2	33,8	4,1	5,8	8,8	11,1	12,7	16,2	8,6	11,4	14,1	17,2	19,8	22,1
Dp Heating	kPa	5,3	9,5	14,0	18,2	24,3	30,8	3,4	4,8	7,5	9,6	11,0	14,2	7,3	9,9	12,3	15,2	17,8	20,1
Fan	W	14	21	28	34	44	57	18	22	32	39	46	61	37	46	55	67	78	88
Sound power	Lw dB(A)	27	33	39	43	47	52	26	31	37	41	43	48	37	42	46	49	52	54
Sound pressure (*)	Lp dB(A)	18	24	30	34	38	43	17	22	28	32	34	39	28	33	37	40	43	45

MODEL		TEC 7.3-2T						TEC 8.3-2T						TEC 9.3-2T					
		1	2	3	4	5	6	1	2	3	4	5	6	1	2	3	4	5	6
Speed		MIN		MED		MAX		MIN		MED		MAX		MIN		MED		MAX	
Air flow	m³/h	445	535	630	735	840	925	510	655	815	1020	1100	1200	735	830	980	1210	1365	1500
Cooling total emission	kW	2,82	3,29	3,74	4,21	4,66	5,01	3,01	3,68	4,32	5,09	5,36	5,69	4,00	4,38	4,95	5,74	6,21	6,56
Cooling sensible emission	kW	2,08	2,45	2,80	3,19	3,56	3,85	2,27	2,82	3,35	4,02	4,26	4,55	3,08	3,40	3,89	4,60	5,03	5,37
Heating	kW	2,83	3,34	3,83	4,33	4,83	5,23	3,22	4,02	4,78	5,75	6,11	6,55	4,42	4,86	5,58	6,62	7,26	7,78
Dp Cooling	kPa	12,3	16,2	20,3	25,1	30,1	34,2	7,2	10,3	13,8	18,4	20,2	22,5	11,8	13,8	17,3	22,4	25,9	28,6
Dp Heating	kPa	10,1	13,5	17,2	21,3	25,9	29,7	5,6	8,3	11,3	15,6	17,3	19,6	9,8	11,6	14,8	19,9	23,5	26,5
Fan	W	44	54	66	79	92	103	47	62	81	105	116	130	78	92	108	134	152	176
Sound power	Lw dB(A)	38	42	47	51	54	56	39	45	50	56	58	60	47	50	54	58	62	64
Sound pressure (*)	Lp dB(A)	29	33	38	42	45	47	30	36	41	47	49	51	38	41	45	49	53	55

MIN-MED-MAX = Standard connected speeds.

(*) = The sound pressure levels are 9 dB(A) lower than the sound power levels and apply to the reverberant field of a 100 m³ room and a reverberation time of 0.5 sec.

Technical features

TEC UNITS WITH 4 ROW COIL

2 pipe units.

The following standard rating conditions are used:

COOLING

Entering air temperature +27°C d.b. +19°C w.b.
 Water temperature + 7°C E.W.T. +12°C L.W.T.

HEATING

Entering air temperature +20°C
 Water temperature +45°C E.W.T. +40°C L.W.T.

MODEL		TEC 1.4-2T						TEC 2.4-2T						TEC 3.4-2T					
		1	2	3	4	5	6	1	2	3	4	5	6	1	2	3	4	5	6
Speed		MIN		MED		MAX		MIN		MED		MAX		MIN		MED		MAX	
Air flow	m³/h	105	125	150	175	195	220	145	170	220	250	295	340	185	235	270	325	385	440
Cooling total emission	kW	0,65	0,77	0,87	1,00	1,08	1,20	1,00	1,11	1,41	1,56	1,78	2,00	1,32	1,63	1,87	2,17	2,53	2,83
Cooling sensible emission	kW	0,49	0,58	0,66	0,77	0,84	0,94	0,73	0,82	1,05	1,17	1,35	1,53	0,95	1,18	1,36	1,59	1,86	2,09
Heating	kW	0,69	0,80	0,92	1,07	1,17	1,31	0,99	1,11	1,43	1,60	1,83	2,08	1,30	1,62	1,87	2,19	2,59	2,88
Dp Cooling	kPa	1,9	2,5	3,2	4,0	4,7	5,6	4,9	6,1	9,1	11,0	13,9	17,2	3,7	5,3	6,7	8,8	11,5	14,1
Dp Heating	kPa	1,7	2,2	2,8	3,7	4,3	5,3	4,0	4,9	7,6	9,3	11,8	14,8	2,8	4,2	5,4	7,1	9,8	11,5
Fan	W	16	19	21	25	29	33	14	16	22	26	32	40	15	20	25	32	41	49
Sound power	Lw dB(A)	32	34	36	39	42	45	30	33	40	43	47	51	31	36	40	45	49	52
Sound pressure (*)	Lp dB(A)	23	25	27	30	33	36	21	24	31	34	38	42	22	27	31	36	40	43

MODEL		TEC 4.4-2T						TEC 5.4-2T						TEC 6.4-2T					
		1	2	3	4	5	6	1	2	3	4	5	6	1	2	3	4	5	6
Speed		MIN		MED		MAX		MIN		MED		MAX		MIN		MED		MAX	
Air flow	m³/h	185	265	335	400	485	570	250	315	420	495	545	650	415	505	590	680	760	830
Cooling total emission	kW	1,31	1,81	2,25	2,62	3,08	3,50	1,77	2,17	2,79	3,21	3,49	4,03	2,79	3,34	3,81	4,31	4,71	5,04
Cooling sensible emission	kW	0,94	1,32	1,65	1,93	2,30	2,63	1,28	1,58	2,04	2,36	2,58	3,01	2,03	2,45	2,81	3,20	3,52	3,79
Heating	kW	1,28	1,80	2,27	2,64	3,14	3,62	1,71	2,10	2,74	3,16	3,46	4,01	2,82	3,39	3,90	4,46	4,92	5,31
Dp Cooling	kPa	3,4	6,1	9,0	11,7	15,5	19,6	7,3	10,4	16,3	20,8	24,2	31,3	14,4	19,7	24,8	30,9	36,2	40,9
Dp Heating	kPa	2,6	5,0	7,2	9,4	12,8	16,4	5,6	8,1	12,9	16,6	19,5	25,2	11,9	16,5	21,1	26,8	31,8	36,3
Fan	W	14	21	28	34	44	57	18	22	32	39	46	61	37	46	55	67	78	88
Sound power	Lw dB(A)	27	33	39	43	47	52	26	31	37	41	43	48	37	42	46	49	52	54
Sound pressure (*)	Lp dB(A)	18	24	30	34	38	43	17	22	28	32	34	39	28	33	37	40	43	45

MODEL		TEC 7.4-2T						TEC 8.4-2T						TEC 9.4-2T					
		1	2	3	4	5	6	1	2	3	4	5	6	1	2	3	4	5	6
Speed		MIN		MED		MAX		MIN		MED		MAX		MIN		MED		MAX	
Air flow	m³/h	445	535	630	735	840	925	510	655	815	1020	1100	1200	735	830	980	1210	1365	1500
Cooling total emission	kW	2,99	3,51	4,01	4,56	5,08	5,48	3,22	3,97	4,72	5,63	5,94	6,34	4,34	4,79	5,45	6,41	6,98	7,42
Cooling sensible emission	kW	2,18	2,57	2,96	3,39	3,80	4,13	2,38	2,98	3,58	4,33	4,59	4,93	3,28	3,63	4,18	4,98	5,48	5,87
Heating	kW	2,95	3,49	4,03	4,62	5,15	5,59	3,37	4,26	5,14	6,27	6,60	7,20	4,70	5,23	6,01	7,18	7,93	8,52
Dp Cooling	kPa	9,5	12,5	15,9	20,0	24,2	27,7	9,6	14,0	19,0	26,0	28,6	32,2	8,9	10,6	13,4	17,8	20,7	23,2
Dp Heating	kPa	7,5	10,1	13,1	16,6	20,1	23,2	8,5	12,8	17,9	24,9	27,8	31,7	8,3	10,0	12,8	17,6	20,9	23,7
Fan	W	44	54	66	79	92	103	47	62	81	105	116	130	78	92	108	134	152	176
Sound power	Lw dB(A)	38	42	47	51	54	56	39	45	50	56	58	60	47	50	54	58	62	64
Sound pressure (*)	Lp dB(A)	29	33	38	42	45	47	30	36	41	47	49	51	38	41	45	49	53	55

MIN-MED-MAX = Standard connected speeds.

(*) = The sound pressure levels are 9 dB(A) lower than the sound power levels and apply to the reverberant field of a 100 m³ room and a reverberation time of 0.5 sec.

Technical features

TEC UNITS WITH 1 ROW ADDITIONAL COIL

4 pipe units.

The following standard rating conditions are used:

COOLING

Entering air temperature +27°C d.b. +19°C w.b.
 Water temperature +7°C E.W.T. +12°C L.W.T.

HEATING

Entering air temperature +20°C
 Water temperature +65°C E.W.T. +55°C L.W.T.

MODEL		TEC 1.3-4T						TEC 2.3-4T						TEC 3.3-4T					
		1	2	3	4	5	6	1	2	3	4	5	6	1	2	3	4	5	6
Speed																			
		MIN			MED		MAX	MIN			MED		MAX		MIN		MED		MAX
Air flow	m³/h	105	125	150	175	195	220	145	170	220	250	295	340	185	235	270	325	385	440
Cooling total emission	kW	0,57	0,66	0,75	0,84	0,91	1,00	0,90	0,99	1,23	1,35	1,53	1,70	1,27	1,55	1,76	2,04	2,35	2,61
Cooling sensible emission	kW	0,45	0,53	0,60	0,69	0,75	0,83	0,68	0,76	0,95	1,06	1,21	1,36	0,92	1,13	1,30	1,51	1,76	1,97
Heating	kW	0,55	0,62	0,69	0,77	0,83	0,91	0,83	0,91	1,09	1,19	1,33	1,47	1,19	1,40	1,56	1,76	1,99	2,18
Dp Cooling	kPa	0,9	1,1	1,4	1,7	2,0	2,3	2,5	3,0	4,4	5,3	6,5	7,9	6,6	9,4	11,8	15,3	19,7	23,8
Dp Heating	kPa	0,5	0,7	0,8	1,0	1,1	1,3	1,3	1,6	2,2	2,5	3,1	3,7	3,2	4,2	5,1	6,3	7,8	9,2
Fan	W	16	19	21	25	29	33	14	16	22	26	32	40	15	20	25	32	41	49
Sound power	Lw dB(A)	32	34	36	39	42	45	30	33	40	43	47	51	31	36	40	45	49	52
Sound pressure (*)	Lp dB(A)	23	25	27	30	33	36	21	24	31	34	38	42	22	27	31	36	40	43

MODEL		TEC 4.3-4T						TEC 5.3-4T						TEC 6.3-4T					
		1	2	3	4	5	6	1	2	3	4	5	6	1	2	3	4	5	6
Speed																			
			MIN		MED		MAX		MIN		MED		MAX	MIN		MED		MAX	
Air flow	m³/h	185	265	335	400	485	570	250	315	420	495	545	650	415	505	590	680	760	830
Cooling total emission	kW	1,25	1,71	2,11	2,43	2,83	3,19	1,66	2,01	2,55	2,90	3,13	3,58	2,50	2,94	3,32	3,70	4,01	4,26
Cooling sensible emission	kW	0,91	1,26	1,57	1,82	2,15	2,45	1,22	1,49	1,91	2,19	2,39	2,76	1,87	2,23	2,54	2,86	3,12	3,35
Heating	kW	1,18	1,52	1,81	2,04	2,33	2,60	1,55	1,84	2,22	2,50	2,66	3,00	2,19	2,51	2,79	3,09	3,33	3,53
Dp Cooling	kPa	6,5	11,2	16,2	20,8	27,2	33,8	5,4	7,6	11,5	14,6	16,7	21,1	8,6	11,4	14,1	17,2	19,8	22,1
Dp Heating	kPa	3,1	4,9	6,6	8,2	10,3	12,5	1,0	1,3	1,9	2,3	2,6	3,2	1,8	2,3	2,8	3,3	3,8	4,2
Fan	W	14	21	28	34	44	57	18	22	32	39	46	61	37	46	55	67	78	88
Sound power	Lw dB(A)	27	33	39	43	47	52	26	31	37	41	43	48	37	42	46	49	52	54
Sound pressure (*)	Lp dB(A)	18	24	30	34	38	43	17	22	28	32	34	39	28	33	37	40	43	45

MODEL		TEC 7.3-4T						TEC 8.3-4T						TEC 9.3-4T					
		1	2	3	4	5	6	1	2	3	4	5	6	1	2	3	4	5	6
Speed																			
			MIN		MED		MAX		MIN		MED		MAX		MIN		MED		MAX
Air flow	m³/h	445	535	630	735	840	925	510	655	815	1020	1100	1200	735	830	980	1210	1365	1500
Cooling total emission	kW	2,82	3,29	3,74	4,21	4,66	5,01	3,01	3,68	4,32	5,09	5,36	5,69	4,00	4,38	4,95	5,74	6,21	6,56
Cooling sensible emission	kW	2,08	2,45	2,80	3,19	3,56	3,85	2,27	2,82	3,35	4,02	4,26	4,55	3,08	3,40	3,89	4,60	5,03	5,37
Heating	kW	2,54	2,89	3,23	3,59	3,94	4,20	2,66	3,16	3,66	4,26	4,48	4,75	3,41	3,71	4,15	4,79	5,17	5,46
Dp Cooling	kPa	12,3	16,2	20,3	25,1	30,1	34,2	7,2	10,3	13,8	18,4	20,2	22,5	12,5	14,6	18,2	23,6	27,3	30,1
Dp Heating	kPa	2,8	3,5	4,2	5,1	6,0	6,7	3,0	4,1	5,3	6,9	7,5	8,3	4,7	5,4	6,6	8,5	9,7	10,7
Fan	W	44	54	66	79	92	103	47	62	81	105	116	130	78	92	108	134	152	176
Sound power	Lw dB(A)	38	42	47	51	54	56	39	45	50	56	58	60	47	50	54	58	62	64
Sound pressure (*)	Lp dB(A)	29	33	38	42	45	47	30	36	41	47	49	51	38	41	45	49	53	55

MIN-MED-MAX = Standard connected speeds.

(*) = The sound pressure levels are 9 dB(A) lower than the sound power levels and apply to the reverberant field of a 100 m³ room and a reverberation time of 0.5 sec.

TEC version

Operation limits

Highest water inlet temperature..... + 85 °C

Lowest water inlet temperature..... + 5 °C

for entering water temperatures below + 5°C, contact the technical department

Highest working pressure..... 1000 kPa (10 bars)

Note: For CH model the maximum installation height is 2,8 m.

On heating it must be payed attention to rooms where the floor temperature is particularly low (for example less than 5°C).

In this situation the floor can cool the lower layer of air to a level that can stop the uniform diffusion of the hot air coming from the unit.

Water flow limits for 3 row coil (l/h)

MODEL	TEC 1.3	TEC 2.3	TEC 3.3	TEC 4.3	TEC 5.3	TEC 6.3	TEC 7.3	TEC 8.3	TEC 9.3
Lowest	100	100	100	100	150	150	150	200	200
Highest	400	500	750	750	1000	1000	1500	2000	2000

Water flow limits for 4 row coil (l/h)

MODEL	TEC 1.4	TEC 2.4	TEC 3.4	TEC 4.4	TEC 5.4	TEC 6.4	TEC 7.4	TEC 8.4	TEC 9.4
Lowest	100	100	150	150	150	150	200	300	300
Highest	650	750	1000	1000	1000	1500	2000	2000	2250

Water flow limits for 1 row additional coil (l/h)

MODEL	TEC 1	TEC 2	TEC 3	TEC 4	TEC 5	TEC 6	TEC 7	TEC 8	TEC 9
Lowest	50	50	50	50	100	100	100	100	100
Highest	200	250	350	350	450	500	650	700	750

Water flow limits for 2 row additional coil (l/h)

MODEL	TEC 1	TEC 2	TEC 3	TEC 4	TEC 5	TEC 6	TEC 7	TEC 8	TEC 9
Lowest	50	50	100	100	100	100	100	100	100
Highest	200	250	350	350	450	500	650	700	750

Motor electrical data (max. absorption)

MODEL		TEC 1	TEC 2	TEC 3	TEC 4	TEC 5	TEC 6	TEC 7	TEC 8	TEC 9
230/1 50Hz	W	33	40	49	57	61	88	103	130	176
	A	0,16	0,18	0,23	0,26	0,27	0,39	0,47	0,58	0,78

Cooling emission of 3 row coil

Entering air temperature: 27°C – R.H.: 50%

MODEL	Speed		WT: 7/12 °C					WT: 8/13 °C				WT: 10/15 °C				WT: 12/17 °C			
			Qv	Pc	Ps	Qw	Dp(c)	Pc	Ps	Qw	Dp(c)	Pc	Ps	Qw	Dp(c)	Pc	Ps	Qw	Dp(c)
			m³/h	kW	kW	l/h	kPa	kW	kW	l/h	kPa	kW	kW	l/h	kPa	kW	kW	l/h	kPa
TEC 1.3	VI	MAX	220	1,08	0,83	191	2,7	0,95	0,78	169	2,1	0,69	0,69	124	1,2	0,58	0,58	105	0,9
	V		195	0,99	0,75	175	2,3	0,87	0,70	155	1,8	0,61	0,60	110	1,0	0,52	0,52	95	0,8
	IV	MED	175	0,92	0,69	162	2,0	0,81	0,64	143	1,6	0,58	0,56	103	0,9	0,48	0,48	86	0,6
	III		150	0,81	0,60	143	1,6	0,72	0,56	127	1,3	0,51	0,48	91	0,7	0,42	0,42	76	0,5
	II		125	0,72	0,52	127	1,3	0,64	0,49	114	1,1	0,46	0,42	83	0,6	0,37	0,37	67	0,4
	I	MIN	105	0,62	0,45	110	1,0	0,55	0,42	98	0,8	0,40	0,36	72	0,5	0,31	0,31	57	0,3
TEC 2.3	VI		340	1,84	1,35	323	9,0	1,63	1,27	287	7,3	1,19	1,10	212	4,2	0,96	0,96	172	2,9
	V	MAX	295	1,66	1,20	291	7,5	1,47	1,13	258	6,1	1,08	0,98	191	3,5	0,86	0,86	153	2,3
	IV		250	1,46	1,05	256	6,0	1,30	0,98	229	4,9	0,96	0,85	170	2,9	0,75	0,75	134	1,8
	III	MED	220	1,33	0,95	232	5,1	1,19	0,89	208	4,1	0,88	0,77	155	2,4	0,68	0,68	120	1,5
	II		170	1,07	0,75	187	3,5	0,96	0,70	169	2,8	0,71	0,61	126	1,7	0,54	0,54	96	1,0
	I	MIN	145	0,97	0,68	169	2,9	0,86	0,63	150	2,3	0,65	0,55	114	1,4	0,49	0,49	86	0,8
TEC 3.3	VI		440	2,81	1,96	492	27,1	2,52	1,84	442	22,3	1,90	1,60	335	13,5	1,41	1,41	251	8,0
	V	MAX	385	2,53	1,75	442	22,4	2,27	1,65	397	18,4	1,72	1,43	303	11,2	1,26	1,26	224	6,5
	IV		325	2,20	1,51	384	17,4	1,97	1,42	344	14,4	1,50	1,23	263	8,8	1,08	1,08	191	5,0
	III	MED	270	1,90	1,30	330	13,4	1,70	1,22	296	11,1	1,30	1,06	227	6,8	0,94	0,94	165	3,8
	II	MIN	235	1,66	1,13	289	10,6	1,50	1,06	261	8,8	1,14	0,92	200	5,4	0,81	0,81	143	3,0
	I		185	1,37	0,93	237	7,5	1,23	0,87	213	6,2	0,95	0,75	165	3,9	0,66	0,66	115	2,1
TEC 4.3	VI		570	3,43	2,44	600	38,5	3,07	2,29	538	31,5	2,30	1,99	406	19,0	1,75	1,75	311	11,7
	V	MAX	485	3,04	2,14	530	31,0	2,73	2,01	476	25,4	2,06	1,75	361	15,4	1,54	1,54	272	9,2
	IV		400	2,62	1,82	456	23,7	2,35	1,71	409	19,5	1,78	1,49	311	11,8	1,31	1,31	230	6,9
	III	MED	335	2,27	1,57	396	18,5	2,04	1,47	356	15,2	1,55	1,28	272	9,3	1,12	1,12	198	5,3
	II	MIN	265	1,84	1,26	320	12,8	1,66	1,18	289	10,5	1,27	1,03	222	6,5	0,91	0,91	160	3,6
	I		185	1,35	0,92	234	7,3	1,22	0,86	212	6,1	0,94	0,75	163	3,8	0,66	0,66	115	2,0
TEC 5.3	VI	MAX	650	3,86	2,75	674	23,0	3,45	2,58	604	18,9	2,59	2,25	456	11,4	1,97	1,97	349	7,0
	V		545	3,37	2,37	588	18,1	3,02	2,23	528	14,9	2,27	1,94	399	9,0	1,70	1,70	301	5,4
	IV	MED	495	3,12	2,19	544	15,8	2,80	2,05	488	12,9	2,11	1,78	370	7,9	1,57	1,57	277	4,6
	III		420	2,75	1,91	478	12,5	2,46	1,79	428	10,3	1,87	1,56	327	6,3	1,37	1,37	241	3,6
	II	MIN	315	2,16	1,49	375	8,3	1,95	1,40	339	6,8	1,48	1,21	258	4,1	1,07	1,07	187	2,4
	I		250	1,78	1,22	310	5,9	1,60	1,14	279	4,9	1,22	0,99	213	3,0	0,87	0,87	153	1,6
TEC 6.3	VI		830	4,60	3,33	807	25,2	4,10	3,13	721	20,6	3,06	2,72	542	12,3	2,39	2,39	427	7,9
	V	MAX	760	4,32	3,11	757	22,6	3,86	2,92	678	18,5	2,89	2,55	511	11,0	2,23	2,23	397	7,0
	IV		680	3,99	2,85	698	19,6	3,57	2,68	626	16,0	2,67	2,33	471	9,6	2,04	2,04	363	6,0
	III	MED	590	3,58	2,53	624	16,0	3,20	2,38	559	13,1	2,41	2,07	423	7,9	1,82	1,82	322	4,8
	II		505	3,16	2,22	552	13,0	2,83	2,08	495	10,6	2,14	1,81	377	6,4	1,59	1,59	282	3,8
	I	MIN	415	2,69	1,87	470	9,7	2,41	1,75	421	8,0	1,82	1,52	320	4,9	1,34	1,34	237	2,8
TEC 7.3	VI	MAX	925	5,40	3,84	946	38,8	4,83	3,18	848	31,9	3,64	3,14	643	19,3	2,76	2,76	492	11,9
	V		840	5,03	3,55	881	34,2	4,50	28,01	789	28,1	3,40	2,91	600	17,1	2,55	2,55	454	10,3
	IV	MED	735	4,54	3,18	795	28,6	4,07	23,42	714	23,5	3,08	2,60	544	14,3	2,28	2,28	406	8,5
	III		630	4,02	2,79	703	23,1	3,61	18,93	633	19,0	2,73	2,28	482	11,6	2,00	2,00	356	6,7
	II	MIN	535	3,54	2,45	617	18,3	3,18	15,05	556	15,1	2,42	1,99	425	9,3	1,75	1,75	310	5,3
	I		445	3,04	2,08	530	14,0	2,73	11,56	476	11,6	2,09	1,70	366	7,2	1,50	1,50	265	4,0
TEC 8.3	VI	MAX	1200	6,14	4,52	1078	21,7	5,46	4,25	961	17,6	4,03	3,71	716	10,3	3,23	3,23	578	7,0
	V		1100	5,78	4,23	1015	19,5	5,15	3,97	906	15,8	3,81	3,46	676	9,3	3,02	3,02	540	6,2
	IV	MED	1020	5,50	4,00	963	17,7	4,90	3,76	860	14,4	3,63	3,27	642	8,5	2,86	2,86	509	5,6
	III		815	4,67	3,34	817	13,3	4,17	3,14	731	10,8	3,11	2,73	549	6,5	2,39	2,39	425	4,1
	II	MIN	655	3,97	2,81	693	9,9	3,55	2,63	621	8,1	2,66	2,29	468	4,9	2,02	2,02	358	3,0
	I		510	3,24	2,26	566	7,0	2,91	2,12	509	5,7	2,19	1,84	385	3,5	1,62	1,62	287	2,0
TEC 9.3	VI	MAX	1500	7,09	5,32	1250	28,1	6,30	5,01	1115	22,8	4,62	4,38	826	13,2	3,80	3,80	685	9,4
	V		1365	6,71	5,00	1180	25,4	5,96	4,70	1051	20,6	4,39	4,10	781	12,0	3,57	3,57	640	8,4
	IV	MED	1210	6,20	4,57	1089	22,0	5,51	4,29	970	17,9	4,07	3,75	722	10,5	3,27	3,27	585	7,1
	III		980	5,34	3,87	937	16,9	4,76	3,64	838	13,8	3,53	3,16	626	8,2	2,77	2,77	495	5,3
	II	MIN	830	4,73	3,39	829	13,6	4,22	3,18	741	11,1	3,14	2,76	556	6,6	2,42	2,42	432	4,2
	I		735	4,32	3,07	757	11,6	3,85	2,88	676	9,5	2,88	2,50	509	5,7	2,19	2,19	390	3,5

LEGEND

- WT = Water temperature
- Pc = Cooling total emission
- Ps = Cooling sensible emission
- Qw = Water flow
- Dp(c) = Water pressure drop
- Speed = Fan speed
- MAX = High speed
- MED = Medium speed
- MIN = Low speed
- Qv = Air flow

Cooling emission of 3 row coil

Entering air temperature: 26°C – R.H.: 50%

MODEL	Speed		WT: 7/12 °C					WT: 8/13 °C				WT: 10/15 °C				WT: 12/17 °C			
			Qv	Pc	Ps	Qw	Dp(c)	Pc	Ps	Qw	Dp(c)	Pc	Ps	Qw	Dp(c)	Pc	Ps	Qw	Dp(c)
			m³/h	kW	kW	l/h	kPa	kW	kW	l/h	kPa	kW	kW	l/h	kPa	kW	kW	l/h	kPa
TEC 1.3	VI	MAX	220	0,95	0,78	169	2,2	0,82	0,73	146	1,7	0,64	0,64	115	1,1	0,52	0,52	95	0,8
	V		195	0,87	0,70	155	1,8	0,75	0,65	134	1,4	0,57	0,57	103	0,9	0,47	0,47	86	0,6
	IV	MED	175	0,81	0,64	143	1,6	0,70	0,60	124	1,2	0,53	0,53	95	0,8	0,44	0,44	79	0,5
	III		150	0,71	0,56	126	1,3	0,62	0,52	110	1,0	0,46	0,46	83	0,6	0,38	0,38	69	0,4
	II		125	0,63	0,49	112	1,1	0,55	0,46	98	0,8	0,40	0,40	72	0,5	0,33	0,33	60	0,3
	I	MIN	105	0,55	0,42	98	0,8	0,47	0,39	84	0,6	0,35	0,35	64	0,4	0,28	0,28	52	0,3
TEC 2.3	VI		340	1,62	1,27	286	7,3	1,42	1,19	251	5,7	1,05	1,05	187	3,4	0,87	0,87	157	2,5
	V	MAX	295	1,46	1,13	256	6,0	1,28	1,06	225	4,8	0,94	0,94	167	2,8	0,78	0,78	139	2,0
	IV		250	1,29	0,98	227	4,9	1,13	0,92	200	3,9	0,82	0,82	146	2,2	0,68	0,68	122	1,6
	III	MED	220	1,18	0,89	206	4,1	1,04	0,83	182	3,3	0,72	0,71	127	1,7	0,62	0,62	110	1,3
	II		170	0,95	0,70	167	2,8	0,83	0,66	146	2,2	0,59	0,56	105	1,2	0,49	0,49	88	0,9
	I	MIN	145	0,86	0,63	150	2,3	0,76	0,59	132	1,9	0,54	0,51	95	1,0	0,44	0,44	77	0,7
TEC 3.3	VI		440	2,50	1,85	439	22,2	2,21	1,72	389	17,8	1,58	1,48	280	9,9	1,28	1,28	229	6,8
	V	MAX	385	2,25	1,65	394	18,4	1,99	1,54	349	14,7	1,43	1,32	253	8,3	1,15	1,15	205	5,6
	IV		325	1,96	1,42	342	14,3	1,73	1,33	303	11,5	1,25	1,14	220	6,5	0,99	0,99	175	4,3
	III	MED	270	1,69	1,22	294	11,0	1,50	1,14	261	8,9	1,09	0,98	191	5,0	0,86	0,86	151	3,3
	II	MIN	235	1,48	1,06	258	8,8	1,32	0,99	230	7,1	0,96	0,85	169	4,0	0,74	0,74	131	2,6
	I		185	1,22	0,87	212	6,2	1,09	0,81	189	5,0	0,80	0,70	139	2,9	0,61	0,61	107	1,8
TEC 4.3	VI		570	3,05	2,29	535	31,5	2,69	2,14	473	25,1	1,91	1,84	339	13,8	1,60	1,60	286	10,0
	V	MAX	485	2,71	2,02	473	25,3	2,39	1,89	418	20,3	1,71	1,62	301	11,2	1,41	1,41	249	7,9
	IV		400	2,33	1,72	406	19,4	2,06	1,60	359	15,5	1,49	1,38	261	8,7	1,20	1,20	212	5,9
	III	MED	335	2,02	1,47	353	15,1	1,79	1,38	313	12,2	1,29	1,18	227	6,9	1,03	1,03	182	4,5
	II	MIN	265	1,65	1,19	287	10,5	1,46	1,11	255	8,5	1,06	0,95	186	4,8	0,83	0,83	146	3,1
	I		185	1,21	0,86	210	6,1	1,08	0,81	187	4,9	0,79	0,69	138	2,8	0,60	0,60	105	1,7
TEC 5.3	VI	MAX	650	3,43	2,59	600	18,8	3,02	2,42	530	15,0	2,14	2,08	378	8,1	1,80	1,80	320	6,0
	V		545	3,00	2,23	525	14,9	2,65	2,09	464	11,9	1,89	1,79	334	6,5	1,55	1,55	275	4,6
	IV	MED	495	2,78	2,06	485	12,9	2,45	1,92	428	10,3	1,76	1,65	310	5,8	1,43	1,43	253	4,0
	III		420	2,45	1,80	427	10,3	2,16	1,68	377	8,3	1,56	1,44	273	4,6	1,25	1,25	220	3,1
	II	MIN	315	1,93	1,40	335	6,8	1,71	1,31	298	5,4	1,24	1,12	217	3,1	0,98	0,98	172	2,0
	I		250	1,59	1,14	277	4,9	1,41	1,07	246	3,9	1,03	0,91	181	2,3	0,80	0,80	141	1,4
TEC 6.3	VI		830	4,09	3,13	719	20,6	3,59	2,93	633	16,3	2,60	2,60	463	9,3	2,17	2,17	389	6,8
	V	MAX	760	3,84	2,93	674	18,4	3,38	2,74	595	14,7	2,38	2,35	423	7,9	2,03	2,02	363	6,0
	IV		680	3,55	2,68	623	16,0	3,12	2,51	549	12,7	2,21	2,15	392	6,9	1,86	1,86	332	5,1
	III	MED	590	3,18	2,38	556	13,1	2,81	2,23	492	10,5	2,00	1,91	353	5,7	1,66	1,66	294	4,1
	II		505	2,82	2,09	494	10,6	2,49	1,95	437	8,5	1,77	1,67	313	4,7	1,45	1,45	258	3,3
	I	MIN	415	2,40	1,76	420	8,0	2,12	1,64	372	6,4	1,52	1,41	268	3,6	1,22	1,22	217	2,4
TEC 7.3	VI	MAX	925	4,81	3,61	845	31,8	4,24	3,38	746	25,4	3,02	2,91	537	14,0	2,16	2,16	389	6,8
	V		840	4,48	3,34	786	28,0	3,95	3,13	695	22,5	2,82	2,69	501	12,5	2,02	2,02	363	6,0
	IV	MED	735	4,04	2,99	709	23,4	3,57	2,80	628	18,8	2,56	2,40	454	10,5	1,85	1,85	332	5,1
	III		630	3,58	2,63	628	18,9	3,17	2,46	557	15,2	2,28	2,11	404	8,6	1,64	1,64	294	4,1
	II	MIN	535	3,16	2,30	552	15,1	2,80	2,15	490	12,1	2,03	1,85	358	6,9	1,45	1,45	258	3,3
	I		445	2,72	1,96	475	11,5	2,41	1,83	421	9,3	1,75	1,57	308	5,3	1,22	1,22	217	2,4
TEC 8.3	VI	MAX	1200	5,44	4,26	958	17,6	4,77	3,99	843	13,9	3,53	3,53	630	8,2	2,94	2,94	528	6,0
	V		1100	5,13	3,98	903	15,8	4,49	3,72	793	12,5	3,30	3,30	588	7,3	2,75	2,75	494	5,3
	IV	MED	1020	4,88	3,76	857	14,4	4,28	3,52	753	11,4	3,12	3,12	554	6,6	2,60	2,60	464	4,8
	III		815	4,14	3,15	726	10,8	3,64	2,94	640	8,6	2,56	2,52	454	4,6	2,18	2,18	389	3,5
	II	MIN	655	3,53	2,64	617	8,1	3,11	2,47	545	6,5	2,20	2,11	389	3,5	1,84	1,84	327	2,6
	I		510	2,89	2,13	506	5,7	2,55	1,99	447	4,6	1,82	1,70	322	2,5	1,48	1,48	263	1,7
TEC 9.3	VI	MAX	1500	5,39	4,21	958	17,6	5,48	4,70	974	18,0	4,16	4,16	746	11,1	3,45	3,45	624	8,0
	V		1365	5,10	3,95	903	15,8	5,20	4,41	920	16,3	3,91	3,91	698	9,9	3,25	3,25	585	7,1
	IV	MED	1210	4,85	3,73	857	14,4	4,81	4,03	850	14,1	3,57	3,57	636	8,4	2,97	2,97	533	6,1
	III		980	4,11	3,12	726	10,8	4,15	3,41	733	10,9	3,02	3,02	538	6,2	2,51	2,51	451	4,5
	II	MIN	830	3,50	2,61	617	8,1	3,69	2,98	650	8,8	2,59	2,55	461	4,7	2,20	2,20	394	3,6
	I		735	2,86	2,10	506	5,7	3,37	2,70	593	7,5	2,37	2,31	421	4,1	1,99	1,99	356	3,0

LEGEND

- WT = Water temperature
- Pc = Cooling total emission
- Ps = Cooling sensible emission
- Qw = Water flow
- Dp(c) = Water pressure drop
- Speed = Fan speed
- MAX = High speed
- MED = Medium speed
- MIN = Low speed
- Qv = Air flow

Cooling emission of 3 row coil

Entering air temperature: 25°C – R.H.: 50%

MODEL	Speed		WT: 7/12 °C					WT: 8/13 °C				WT: 10/15 °C				WT: 12/17 °C			
			Qv	Pc	Ps	Qw	Dp(c)	Pc	Ps	Qw	Dp(c)	Pc	Ps	Qw	Dp(c)	Pc	Ps	Qw	Dp(c)
			m³/h	kW	kW	l/h	kPa	kW	kW	l/h	kPa	kW	kW	l/h	kPa	kW	kW	l/h	kPa
TEC 1.3	VI	MAX	220	0,82	0,73	146	1,7	0,68	0,67	122	1,2	0,58	0,58	105	0,9	0,47	0,47	86	0,6
	V		195	0,75	0,65	134	1,4	0,62	0,60	112	1,1	0,52	0,52	95	0,8	0,42	0,42	77	0,5
	IV	MED	175	0,70	0,60	124	1,2	0,59	0,56	105	0,9	0,48	0,48	86	0,7	0,39	0,39	71	0,5
	III		150	0,62	0,52	110	1,0	0,52	0,48	93	0,7	0,42	0,42	76	0,5	0,34	0,34	62	0,4
	II		125	0,55	0,46	98	0,8	0,46	0,42	83	0,6	0,37	0,37	67	0,4	0,30	0,30	55	0,3
	I	MIN	105	0,47	0,39	84	0,6	0,40	0,36	72	0,5	0,31	0,31	57	0,3	0,25	0,25	46	0,2
TEC 2.3	VI		340	1,42	1,19	251	5,8	1,21	1,11	215	4,4	0,96	0,96	172	2,9	0,78	0,78	141	2,0
	V	MAX	295	1,28	1,06	225	4,8	1,09	0,98	193	3,6	0,86	0,86	153	2,4	0,70	0,70	126	1,7
	IV		250	1,13	0,92	200	3,9	0,97	0,86	172	2,9	0,75	0,75	134	1,9	0,61	0,61	110	1,3
	III	MED	220	1,03	0,84	181	3,3	0,89	0,78	157	2,5	0,68	0,68	120	1,6	0,56	0,56	100	1,1
	II		170	0,83	0,66	146	2,2	0,72	0,61	127	1,7	0,54	0,54	96	1,0	0,44	0,44	79	0,7
	I	MIN	145	0,75	0,59	131	1,9	0,65	0,55	114	1,4	0,49	0,49	86	0,9	0,40	0,40	71	0,6
TEC 3.3	VI		440	2,20	1,73	387	17,8	1,91	1,61	337	13,8	1,41	1,41	251	8,1	1,16	1,16	208	5,8
	V	MAX	385	1,98	1,55	347	14,8	1,72	1,44	303	11,5	1,26	1,26	224	6,6	1,04	1,04	186	4,7
	IV		325	1,73	1,33	303	11,5	1,50	1,24	263	9,0	1,09	1,09	193	5,1	0,90	0,90	160	3,6
	III	MED	270	1,49	1,14	260	8,9	1,30	1,06	227	6,9	0,94	0,94	165	3,9	0,78	0,78	138	2,8
	II	MIN	235	1,31	1,00	229	7,1	1,14	0,93	200	5,5	0,82	0,82	144	3,1	0,67	0,67	119	2,2
	I		185	1,08	0,82	187	5,0	0,95	0,76	165	3,9	0,64	0,64	112	2,0	0,55	0,55	96	1,5
TEC 4.3	VI		570	2,68	2,15	471	25,2	2,32	2,00	409	19,5	1,76	1,76	313	11,9	1,44	1,44	258	8,4
	V	MAX	485	2,39	1,89	418	20,3	2,07	1,76	363	15,7	1,55	1,55	273	9,4	1,27	1,27	225	6,6
	IV		400	2,06	1,61	359	15,6	1,78	1,50	311	12,1	1,32	1,32	232	7,0	1,08	1,08	191	5,0
	III	MED	335	1,78	1,38	311	12,2	1,55	1,28	272	9,5	1,13	1,13	200	5,4	0,93	0,93	165	3,8
	II	MIN	265	1,45	1,11	253	8,5	1,27	1,03	222	6,6	0,91	0,91	160	3,7	0,75	0,75	132	2,6
	I		185	1,07	0,81	186	4,9	0,94	0,75	163	3,8	0,64	0,63	112	1,9	0,55	0,55	96	1,5
TEC 5.3	VI	MAX	650	3,02	2,42	530	15,0	2,61	2,26	459	11,6	1,98	1,98	351	7,1	1,62	1,62	289	5,0
	V		545	2,64	2,09	463	11,9	2,28	1,95	401	9,1	1,71	1,71	303	5,5	1,40	1,40	249	3,9
	IV	MED	495	2,45	1,93	428	10,4	2,12	1,79	372	8,0	1,57	1,57	277	4,8	1,29	1,29	229	3,4
	III		420	2,16	1,68	377	8,3	1,87	1,57	327	6,4	1,37	1,37	241	3,8	1,13	1,13	200	2,6
	II	MIN	315	1,71	1,31	298	5,4	1,48	1,22	258	4,3	1,08	1,08	189	2,4	0,89	0,89	157	1,8
	I		250	1,41	1,07	246	3,9	1,23	0,99	215	3,0	0,87	0,87	153	1,6	0,72	0,72	127	1,1
TEC 6.3	VI		830	3,58	2,94	631	16,4	3,09	2,73	547	12,6	2,39	2,39	427	8,1	1,96	1,96	353	5,7
	V	MAX	760	3,37	2,74	593	14,7	2,91	2,56	514	11,3	2,23	2,23	397	7,1	1,83	1,83	329	5,0
	IV		680	3,12	2,51	549	12,8	2,69	2,34	475	9,9	2,05	2,05	365	6,1	1,68	1,68	301	4,3
	III	MED	590	2,80	2,23	490	10,5	2,42	2,08	425	8,1	1,82	1,82	322	4,9	1,50	1,50	267	3,5
	II		505	2,48	1,95	435	8,5	2,14	1,82	377	6,6	1,59	1,59	282	3,9	1,31	1,31	234	2,8
	I	MIN	415	2,11	1,64	370	6,4	1,83	1,53	322	5,0	1,34	1,34	237	2,9	1,10	1,10	196	2,0
TEC 7.3	VI	MAX	925	4,23	3,39	745	25,5	3,66	3,16	647	19,8	2,76	2,76	492	12,1	2,27	2,27	408	8,5
	V		840	3,94	3,14	693	22,5	3,41	2,92	602	17,5	2,56	2,56	456	10,5	2,10	2,10	377	7,4
	IV	MED	735	3,56	2,81	626	18,8	3,09	2,61	545	14,6	2,29	2,29	408	8,6	1,88	1,88	337	6,1
	III		630	3,16	2,46	556	15,2	2,74	2,29	483	11,9	2,01	2,01	358	6,9	1,65	1,65	296	4,9
	II	MIN	535	2,79	2,16	488	12,1	2,42	2,00	425	9,5	1,76	1,76	311	5,4	1,45	1,45	258	3,8
	I		445	2,40	1,84	420	9,3	2,09	1,71	366	7,3	1,51	1,51	267	4,1	1,24	1,24	220	2,9
TEC 8.3	VI	MAX	1200	4,76	3,99	841	14,0	4,08	3,72	724	10,7	3,24	3,24	580	7,1	2,64	2,64	476	5,0
	V		1100	4,49	3,73	793	12,6	3,85	3,47	683	9,6	3,03	3,03	542	6,3	2,47	2,47	445	4,4
	IV	MED	1020	4,27	3,53	752	11,5	3,67	3,28	648	8,8	2,87	2,87	511	5,7	2,34	2,34	420	4,0
	III		815	3,63	2,95	638	8,6	3,13	2,74	552	6,6	2,39	2,39	425	4,1	1,96	1,96	351	2,9
	II	MIN	655	3,10	2,47	544	6,5	2,67	2,30	470	5,0	2,03	2,03	359	3,1	1,66	1,66	296	2,2
	I		510	2,54	1,99	445	4,6	2,20	1,85	387	3,5	1,63	1,63	289	2,1	1,34	1,34	239	1,5
TEC 9.3	VI	MAX	1500	5,49	4,71	975	18,1	4,68	4,39	836	13,7	3,81	3,81	686	9,6	3,10	3,10	564	6,7
	V		1365	5,20	4,42	920	16,4	4,44	4,11	789	12,4	3,58	3,58	642	8,5	2,92	2,92	528	5,9
	IV	MED	1210	4,81	4,04	850	14,2	4,12	3,76	731	10,8	3,27	3,27	585	7,2	2,67	2,67	482	5,1
	III		980	4,15	3,41	733	11,0	3,56	3,17	631	8,4	2,77	2,77	495	5,4	2,26	2,26	408	3,8
	II	MIN	830	3,68	2,98	648	8,8	3,17	2,78	561	6,8	2,42	2,42	432	4,2	1,98	1,98	356	3,0
	I		735	3,36	2,70	592	7,5	2,90	2,51	513	5,8	2,20	2,20	392	3,6	1,80	1,80	323	2,5

LEGEND

- WT = Water temperature
- Pc = Cooling total emission
- Ps = Cooling sensible emission
- Qw = Water flow
- Dp(c) = Water pressure drop
- Speed = Fan speed
- MAX = High speed
- MED = Medium speed
- MIN = Low speed
- Qv = Air flow

Cooling emission of 4 row coil

Entering air temperature: 27°C – R.H.: 50%

MODEL	Speed		WT: 7/12 °C					WT: 8/13 °C				WT: 10/15 °C				WT: 12/17 °C			
			Qv	Pc	Ps	Qw	Dp(c)	Pc	Ps	Qw	Dp(c)	Pc	Ps	Qw	Dp(c)	Pc	Ps	Qw	Dp(c)
			m³/h	kW	kW	l/h	kPa	kW	kW	l/h	kPa	kW	kW	l/h	kPa	kW	kW	l/h	kPa
TEC 1.4	VI	MAX	220	1,30	0,93	229	6,4	1,15	0,88	203	5,2	0,84	0,76	150	3,0	0,67	0,67	120	2,0
	V		195	1,17	0,84	206	5,4	1,04	0,78	184	4,3	0,76	0,68	136	2,5	0,59	0,59	107	1,6
	IV	MED	175	1,08	0,77	189	4,6	0,96	0,72	169	3,7	0,71	0,62	126	2,2	0,55	0,55	98	1,4
	III		150	0,94	0,66	165	3,6	0,84	0,62	148	2,9	0,62	0,53	110	1,7	0,47	0,47	84	1,1
	II		125	0,83	0,58	146	2,9	0,74	0,54	131	2,4	0,55	0,46	98	1,4	0,41	0,41	74	0,9
	I	MIN	105	0,71	0,49	126	2,2	0,63	0,45	112	1,8	0,47	0,39	84	1,1	0,35	0,35	64	0,6
TEC 2.4	VI		340	2,16	1,52	378	19,6	1,93	1,43	339	16,0	1,45	1,24	256	9,6	1,09	1,09	194	5,9
	V	MAX	295	1,92	1,34	335	15,9	1,72	1,26	301	13,0	1,30	1,09	229	7,8	0,96	0,96	170	4,7
	IV		250	1,68	1,16	294	12,5	1,50	1,09	263	10,3	1,13	0,94	200	6,2	0,83	0,83	148	3,6
	III	MED	220	1,52	1,05	265	10,4	1,36	0,98	237	8,6	1,03	0,85	181	5,2	0,75	0,75	132	3,0
	II		170	1,20	0,81	210	6,9	1,07	0,76	187	5,7	0,82	0,66	144	3,5	0,58	0,58	103	1,9
	I	MIN	145	1,07	0,73	186	5,6	0,96	0,68	167	4,6	0,74	0,59	129	2,9	0,52	0,52	91	1,6
TEC 3.4	VI		440	3,04	2,09	531	16,0	2,73	1,96	478	13,2	2,07	1,70	365	8,1	1,50	1,50	267	4,6
	V	MAX	385	2,72	1,86	475	13,1	2,44	1,74	427	10,8	1,85	1,51	325	6,6	1,33	1,33	236	3,7
	IV		325	2,34	1,59	408	10,1	2,11	1,49	368	8,3	1,61	1,29	282	5,1	1,14	1,14	201	2,8
	III	MED	270	2,01	1,36	349	7,6	1,81	1,27	315	6,3	1,38	1,10	241	3,9	0,98	0,98	172	2,1
	II	MIN	235	1,75	1,18	304	6,0	1,57	1,10	273	5,0	1,21	0,95	212	3,1	0,84	0,84	148	1,6
	I		185	1,42	0,96	246	4,1	1,29	0,90	224	3,4	0,99	0,78	172	2,2	0,69	0,69	120	1,1
TEC 4.4	VI		570	3,65	2,54	638	21,2	3,27	2,38	573	17,4	2,47	2,06	435	10,5	1,82	1,82	323	6,2
	V	MAX	485	3,31	2,29	576	17,7	2,97	2,15	518	14,5	2,25	1,86	394	8,8	1,65	1,65	291	5,1
	IV		400	2,82	1,93	490	13,3	2,53	1,81	440	10,9	1,93	1,57	337	6,7	1,39	1,39	244	3,8
	III	MED	335	2,42	1,65	421	10,2	2,18	1,55	380	8,4	1,66	1,34	291	5,2	1,18	1,18	208	2,9
	II	MIN	265	1,95	1,32	339	6,9	1,76	1,24	306	5,7	1,34	1,07	234	3,6	0,95	0,95	167	1,9
	I		185	1,41	0,95	244	3,9	1,27	0,89	220	3,2	0,98	0,77	170	2,0	0,68	0,68	119	1,1
TEC 5.4	VI	MAX	650	4,34	3,00	757	35,5	3,90	2,82	681	29,3	2,96	2,45	519	18,0	2,16	2,16	382	10,3
	V		545	3,75	2,57	654	27,4	3,37	2,41	588	22,7	2,57	2,10	451	14,0	1,85	1,85	327	7,8
	IV	MED	495	3,45	2,36	600	23,6	3,10	2,21	540	19,5	2,37	1,92	415	12,1	1,69	1,69	298	6,7
	III		420	3,00	2,04	521	18,5	2,71	1,92	471	15,3	2,08	1,67	363	9,5	1,47	1,47	258	5,2
	II	MIN	315	2,33	1,57	404	11,8	2,10	1,48	365	9,8	1,62	1,28	282	6,1	1,13	1,13	198	3,2
	I		250	1,90	1,28	330	8,3	1,72	1,20	299	6,9	1,33	1,04	232	4,3	0,87	0,87	153	2,1
TEC 6.4	VI		830	5,43	3,77	949	46,5	4,87	3,54	853	38,3	3,69	3,08	650	23,4	2,71	2,71	482	13,6
	V	MAX	760	5,06	3,51	884	41,1	4,55	3,29	796	33,9	3,45	2,86	607	20,8	2,52	2,52	447	12,0
	IV		680	4,63	3,19	808	35,1	4,16	2,99	728	28,9	3,17	2,60	557	17,8	2,29	2,29	406	10,1
	III	MED	590	4,10	2,81	714	28,1	3,69	2,64	643	23,3	2,81	2,29	492	14,4	2,02	2,02	356	8,0
	II		505	3,58	2,44	624	22,3	3,23	2,29	564	18,4	2,47	1,98	433	11,4	1,75	1,75	310	6,2
	I	MIN	415	3,00	2,03	523	16,3	2,70	1,90	471	13,5	2,08	1,65	365	8,4	1,46	1,46	258	4,5
TEC 7.4	VI	MAX	925	5,90	4,11	1032	31,4	5,29	3,86	927	25,9	4,01	3,36	707	15,8	2,95	2,95	525	9,3
	V		840	5,47	3,79	956	27,5	4,91	3,56	860	22,6	3,72	3,10	655	13,9	2,72	2,72	483	8,0
	IV	MED	735	4,90	3,38	857	22,7	4,40	3,17	771	18,7	3,35	2,76	590	11,5	2,42	2,42	430	6,5
	III		630	4,31	2,95	753	18,1	3,88	2,77	679	14,9	2,95	2,40	519	9,2	2,11	2,11	375	5,1
	II	MIN	535	3,77	2,57	657	14,2	3,39	2,41	592	11,8	2,60	2,09	456	7,3	1,85	1,85	327	4,0
	I		445	3,21	2,18	559	10,7	2,90	2,04	506	8,9	2,22	1,77	389	5,5	1,56	1,56	275	3,0
TEC 8.4	VI	MAX	1200	6,85	4,91	1201	36,0	6,11	4,60	1073	29,3	4,55	4,00	805	17,5	3,50	3,50	624	11,0
	V		1100	6,41	4,57	1123	32,0	5,72	4,29	1004	26,1	4,27	3,72	755	15,5	3,26	3,26	581	9,7
	IV	MED	1020	6,07	4,31	1061	29,0	5,42	4,04	949	23,6	4,05	3,51	714	14,0	3,08	3,08	547	8,6
	III		815	5,09	3,57	889	21,2	4,56	3,35	798	17,3	3,42	2,91	602	10,4	2,57	2,57	456	6,3
	II	MIN	655	4,28	2,98	746	15,7	3,84	2,79	671	12,8	2,89	2,42	507	7,7	2,13	2,13	377	4,5
	I		510	3,46	2,38	604	10,8	3,11	2,23	544	8,8	2,35	1,93	413	5,4	1,70	1,70	301	3,1
TEC 9.4	VI	MAX	1500	8,02	5,83	1410	26,5	7,14	5,47	1259	21,6	5,28	4,76	939	12,7	4,16	4,16	746	8,4
	V		1365	7,54	5,45	1323	23,7	6,72	5,12	1182	19,3	4,98	4,46	882	11,4	3,89	3,89	695	7,4
	IV	MED	1210	6,92	4,96	1213	20,3	6,17	4,66	1084	16,5	4,59	4,05	812	9,8	3,54	3,54	631	6,2
	III		980	5,89	4,17	1032	15,3	5,26	3,91	924	12,5	3,93	3,39	695	7,5	2,97	2,97	530	4,6
	II	MIN	830	5,16	3,62	903	12,1	4,62	3,40	810	9,9	3,46	2,94	611	6,0	2,60	2,60	463	3,6
	I		735	4,69	3,27	820	10,2	4,19	3,06	734	8,4	3,15	2,66	556	5,0	2,34	2,34	416	3,0

LEGEND

- WT = Water temperature
- Pc = Cooling total emission
- Ps = Cooling sensible emission
- Qw = Water flow
- Dp(c) = Water pressure drop
- Speed = Fan speed
- MAX = High speed
- MED = Medium speed
- MIN = Low speed
- Qv = Air flow

Cooling emission of 4 row coil

Entering air temperature: 26°C – R.H.: 50%

MODEL	Speed		WT: 7/12 °C					WT: 8/13 °C				WT: 10/15 °C				WT: 12/17 °C			
			Qv	Pc	Ps	Qw	Dp(c)	Pc	Ps	Qw	Dp(c)	Pc	Ps	Qw	Dp(c)	Pc	Ps	Qw	Dp(c)
			m³/h	kW	kW	l/h	kPa	kW	kW	l/h	kPa	kW	kW	l/h	kPa	kW	kW	l/h	kPa
TEC 1.4	VI	MAX	220	1,14	0,88	201	5,1	1,00	0,82	177	4,0	0,73	0,73	131	2,3	0,60	0,60	108	1,7
	V		195	1,03	0,78	182	4,3	0,90	0,73	160	3,4	0,65	0,65	117	1,9	0,54	0,54	98	1,4
	IV	MED	175	0,95	0,72	167	3,7	0,83	0,67	146	2,9	0,58	0,57	103	1,5	0,50	0,50	89	1,2
	III		150	0,83	0,62	146	2,9	0,73	0,58	129	2,3	0,51	0,49	91	1,2	0,43	0,43	77	0,9
	II		125	0,73	0,54	129	2,4	0,64	0,50	114	1,9	0,45	0,43	81	1,0	0,37	0,37	67	0,7
	I	MIN	105	0,63	0,46	112	1,8	0,55	0,42	98	1,4	0,39	0,36	71	0,8	0,31	0,31	57	0,5
TEC 2.4	VI		340	1,92	1,43	337	16,0	1,69	1,34	298	12,7	1,20	1,14	213	7,0	0,99	0,99	177	5,0
	V	MAX	295	1,71	1,26	299	13,0	1,51	1,18	265	10,3	1,08	1,01	191	5,7	0,88	0,88	157	4,0
	IV		250	1,49	1,09	261	10,3	1,32	1,02	232	8,2	0,95	0,87	169	4,6	0,76	0,76	136	3,1
	III	MED	220	1,35	0,98	236	8,5	1,20	0,92	210	6,8	0,86	0,79	151	3,8	0,69	0,69	122	2,5
	II		170	1,07	0,77	187	5,7	0,95	0,71	167	4,6	0,68	0,61	120	2,6	0,53	0,53	95	1,7
	I	MIN	145	0,96	0,68	167	4,6	0,85	0,64	148	3,7	0,62	0,55	108	2,1	0,48	0,48	84	1,3
TEC 3.4	VI		440	2,71	1,97	475	13,1	2,40	1,83	421	10,6	1,73	1,57	306	5,9	1,37	1,37	244	3,9
	V	MAX	385	2,43	1,75	425	10,8	2,15	1,63	377	8,7	1,55	1,39	273	4,9	1,22	1,22	217	3,2
	IV		325	2,09	1,50	365	8,3	1,86	1,40	325	6,7	1,35	1,19	237	3,8	1,04	1,04	184	2,4
	III	MED	270	1,79	1,28	311	6,3	1,59	1,19	277	5,1	1,16	1,02	203	2,9	0,89	0,89	157	1,8
	II	MIN	235	1,56	1,11	272	4,9	1,39	1,03	243	4,0	1,02	0,88	179	2,3	0,77	0,77	136	1,4
	I		185	1,28	0,90	222	3,4	1,14	0,84	198	2,8	0,84	0,72	146	1,6	0,63	0,63	110	1,0
TEC 4.4	VI		570	3,25	2,39	569	17,3	2,87	2,23	504	13,8	2,06	1,91	365	7,7	1,66	1,66	296	5,3
	V	MAX	485	2,96	2,16	516	14,5	2,61	2,01	456	11,6	1,88	1,72	330	6,5	1,51	1,51	267	4,4
	IV		400	2,52	1,82	439	10,9	2,23	1,70	389	8,8	1,61	1,45	282	4,9	1,27	1,27	224	3,2
	III	MED	335	2,16	1,55	377	8,4	1,92	1,45	335	6,7	1,39	1,24	244	3,8	1,08	1,08	191	2,4
	II	MIN	265	1,74	1,24	303	5,7	1,55	1,16	270	4,6	1,13	0,99	198	2,6	0,87	0,87	153	1,6
	I		185	1,26	0,89	218	3,2	1,12	0,83	194	2,6	0,83	0,71	144	1,5	0,62	0,62	108	0,9
TEC 5.4	VI	MAX	650	3,87	2,83	676	29,1	3,43	2,64	600	23,5	2,49	2,27	439	13,3	1,97	1,97	349	8,8
	V		545	3,35	2,42	585	22,6	2,97	2,26	519	18,2	2,16	1,94	380	10,4	1,69	1,69	299	6,7
	IV	MED	495	3,08	2,22	537	19,4	2,74	2,07	478	15,7	2,00	1,78	351	9,0	1,55	1,55	273	5,7
	III		420	2,69	1,93	468	15,2	2,39	1,80	416	12,3	1,75	1,54	306	7,1	1,35	1,35	237	4,5
	II	MIN	315	2,09	1,48	363	9,7	1,86	1,38	323	7,9	1,37	1,19	239	4,6	1,04	1,04	182	2,8
	I		250	1,70	1,20	296	6,8	1,52	1,12	265	5,6	1,12	0,96	196	3,2	0,84	0,84	148	1,9
TEC 6.4	VI		830	4,84	3,55	848	38,1	4,28	3,32	752	30,6	3,09	2,85	547	17,2	2,48	2,48	442	11,7
	V	MAX	760	4,52	3,30	791	33,8	4,00	3,09	702	27,1	2,89	2,65	511	15,4	2,30	2,30	409	10,2
	IV		680	4,14	3,00	724	28,8	3,66	2,81	642	23,2	2,66	2,41	470	13,2	2,09	2,09	372	8,7
	III	MED	590	3,66	2,64	638	23,1	3,25	2,47	568	18,7	2,37	2,12	416	10,7	1,84	1,84	325	6,8
	II		505	3,20	2,29	559	18,3	2,84	2,14	497	14,8	2,08	1,84	366	8,5	1,60	1,60	284	5,4
	I	MIN	415	2,68	1,91	468	13,4	2,39	1,78	418	10,9	1,75	1,53	308	6,3	1,33	1,33	236	3,9
TEC 7.4	VI	MAX	925	5,26	3,87	922	25,8	4,65	3,62	817	20,7	3,35	3,11	593	11,6	2,70	2,70	482	7,9
	V		840	4,88	3,57	855	22,6	4,32	3,34	759	18,1	3,12	2,86	552	10,2	2,49	2,49	444	6,9
	IV	MED	735	4,38	3,18	767	18,6	3,88	2,97	681	15,0	2,81	2,55	497	8,5	2,21	2,21	394	5,6
	III		630	3,85	2,78	674	14,9	3,41	2,59	599	12,0	2,48	2,22	439	6,8	1,93	1,93	344	4,4
	II	MIN	535	3,37	2,42	588	11,7	2,99	2,26	523	9,4	2,18	1,94	384	5,4	1,69	1,69	299	3,4
	I		445	2,87	2,05	501	8,8	2,56	1,91	447	7,1	1,87	1,64	329	4,1	1,43	1,43	253	2,6
TEC 8.4	VI	MAX	1200	6,08	4,61	1068	29,2	5,33	4,31	939	23,2	3,73	3,70	664	12,4	3,19	3,19	571	9,4
	V		1100	5,69	4,30	999	26,1	5,00	4,01	881	20,7	3,51	3,44	624	11,2	2,97	2,97	531	8,3
	IV	MED	1020	5,39	4,05	944	23,6	4,74	3,79	832	18,7	3,34	3,24	592	10,1	2,80	2,80	499	7,4
	III		815	4,53	3,36	793	17,3	3,99	3,14	700	13,9	2,83	2,68	501	7,6	2,34	2,34	416	5,4
	II	MIN	655	3,81	2,80	666	12,8	3,36	2,61	588	10,3	2,40	2,23	423	5,6	1,95	1,95	346	3,8
	I		510	3,09	2,24	540	8,8	2,73	2,09	478	7,0	1,96	1,78	346	4,0	1,55	1,55	275	2,5
TEC 9.4	VI	MAX	1500	7,11	5,48	1254	21,5	6,22	5,13	1101	17,0	4,54	4,54	812	9,8	3,78	3,78	681	7,1
	V		1365	6,69	5,13	1176	19,3	5,86	4,80	1034	15,2	4,25	4,25	757	8,7	3,54	3,54	635	6,3
	IV	MED	1210	6,14	4,67	1078	16,5	5,39	4,36	949	13,1	3,77	3,74	671	7,0	3,22	3,22	576	5,3
	III		980	5,23	3,92	918	12,5	4,60	3,66	810	9,9	3,24	3,13	576	5,4	2,70	2,70	483	3,9
	II	MIN	830	4,59	3,41	805	9,9	4,04	3,18	710	7,9	2,86	2,72	507	4,3	2,37	2,37	423	3,1
	I		735	4,17	3,07	731	8,3	3,67	2,87	645	6,6	2,61	2,45	463	3,7	2,14	2,14	382	2,6

LEGEND

- WT = Water temperature
- Pc = Cooling total emission
- Ps = Cooling sensible emission
- Qw = Water flow
- Dp(c) = Water pressure drop
- Speed = Fan speed
- MAX = High speed
- MED = Medium speed
- MIN = Low speed
- Qv = Air flow

Cooling emission of 4 row coil

Entering air temperature: 25°C – R.H.: 50%

MODEL	Speed		WT: 7/12 °C					WT: 8/13 °C				WT: 10/15 °C				WT: 12/17 °C			
			Qv	Pc	Ps	Qw	Dp(c)	Pc	Ps	Qw	Dp(c)	Pc	Ps	Qw	Dp(c)	Pc	Ps	Qw	Dp(c)
			m³/h	kW	kW	l/h	kPa	kW	kW	l/h	kPa	kW	kW	l/h	kPa	kW	kW	l/h	kPa
TEC 1.4	VI	MAX	220	1,00	0,82	177	4,1	0,85	0,76	151	3,1	0,67	0,67	120	2,0	0,54	0,54	98	1,4
	V		195	0,90	0,73	160	3,4	0,77	0,68	138	2,6	0,60	0,60	108	1,7	0,48	0,48	88	1,2
	IV	MED	175	0,83	0,67	146	2,9	0,71	0,62	126	2,2	0,55	0,55	98	1,4	0,45	0,45	81	1,0
	III		150	0,73	0,58	129	2,3	0,62	0,54	110	1,8	0,47	0,47	84	1,1	0,38	0,38	69	0,8
	II		125	0,64	0,50	114	1,9	0,55	0,47	98	1,4	0,41	0,41	74	0,9	0,34	0,34	62	0,6
	I	MIN	105	0,55	0,42	98	1,4	0,47	0,39	84	1,1	0,35	0,35	64	0,7	0,28	0,28	52	0,5
TEC 2.4	VI		340	1,69	1,34	298	12,8	1,46	1,24	258	9,8	1,09	1,09	194	6,0	0,90	0,90	162	4,2
	V	MAX	295	1,51	1,18	265	10,4	1,30	1,10	229	8,0	0,97	0,97	172	4,7	0,79	0,79	141	3,4
	IV		250	1,32	1,02	232	8,2	1,14	0,95	201	6,4	0,83	0,83	148	3,7	0,68	0,68	122	2,6
	III	MED	220	1,19	0,92	208	6,8	1,03	0,85	181	5,3	0,75	0,75	132	3,0	0,62	0,62	110	2,1
	II		170	0,94	0,72	165	4,6	0,82	0,66	144	3,5	0,59	0,59	105	2,0	0,48	0,48	86	1,4
	I	MIN	145	0,85	0,64	148	3,7	0,74	0,59	129	2,9	0,53	0,53	93	1,6	0,43	0,43	76	1,1
TEC 3.4	VI		440	2,39	1,84	420	10,6	2,07	1,71	365	8,2	1,50	1,50	267	4,7	1,24	1,24	222	3,3
	V	MAX	385	2,14	1,64	375	8,7	1,86	1,52	327	6,7	1,34	1,34	237	3,8	1,10	1,10	196	2,7
	IV		325	1,85	1,40	323	6,7	1,61	1,30	282	5,2	1,15	1,15	203	2,9	0,95	0,95	169	2,0
	III	MED	270	1,59	1,20	277	5,1	1,38	1,11	241	4,0	0,93	0,93	163	2,0	0,81	0,81	143	1,5
	II	MIN	235	1,38	1,04	241	4,0	1,21	0,96	212	3,1	0,82	0,80	144	1,6	0,70	0,70	124	1,2
	I		185	1,13	0,84	196	2,8	0,99	0,78	172	2,2	0,68	0,66	119	1,1	0,57	0,57	100	0,8
TEC 4.4	VI		570	2,95	2,31	518	14,6	2,56	2,15	451	11,3	1,89	1,89	335	6,7	1,50	1,50	268	4,5
	V	MAX	485	2,60	2,02	454	11,6	2,26	1,87	396	9,0	1,65	1,65	291	5,2	1,36	1,36	241	3,7
	IV		400	2,22	1,70	387	8,8	1,93	1,58	337	6,8	1,40	1,40	246	3,8	1,15	1,15	203	2,7
	III	MED	335	1,91	1,45	334	6,7	1,66	1,35	291	5,3	1,19	1,19	210	2,9	0,98	0,98	174	2,1
	II	MIN	265	1,54	1,16	268	4,6	1,34	1,08	234	3,6	0,91	0,90	160	1,8	0,79	0,79	139	1,4
	I		185	1,12	0,83	194	2,6	0,98	0,77	170	2,0	0,67	0,65	117	1,0	0,56	0,56	98	0,8
TEC 5.4	VI	MAX	650	3,42	2,65	599	23,5	2,97	2,46	521	18,3	2,16	2,16	382	10,5	1,78	1,78	316	7,4
	V		545	2,96	2,27	518	18,2	2,58	2,11	452	14,2	1,85	1,85	327	8,0	1,53	1,53	272	5,7
	IV	MED	495	2,72	2,08	475	15,7	2,38	1,93	416	12,3	1,70	1,70	299	6,8	1,40	1,40	248	4,8
	III		420	2,38	1,80	415	12,3	2,08	1,68	363	9,7	1,48	1,48	260	5,3	1,22	1,22	215	3,8
	II	MIN	315	1,85	1,39	322	7,9	1,62	1,29	282	6,2	1,11	1,09	194	3,2	0,94	0,94	165	2,4
	I		250	1,51	1,13	263	5,5	1,32	1,05	230	4,4	0,91	0,88	160	2,3	0,76	0,76	134	1,6
TEC 6.4	VI		830	4,27	3,33	750	30,7	3,70	3,09	652	23,9	2,72	2,72	483	13,9	2,24	2,24	401	9,9
	V	MAX	760	3,99	3,09	700	27,2	3,46	2,87	609	21,2	2,53	2,53	449	12,2	2,08	2,08	372	8,6
	IV		680	3,65	2,81	640	23,2	3,17	2,62	557	18,1	2,30	2,30	408	10,3	1,89	1,89	337	7,3
	III	MED	590	3,24	2,48	566	18,7	2,82	2,30	494	14,6	2,02	2,02	356	8,1	1,67	1,67	296	5,8
	II		505	2,83	2,15	495	14,8	2,47	2,00	433	11,6	1,75	1,75	310	6,4	1,45	1,45	258	4,5
	I	MIN	415	2,38	1,79	416	10,9	2,08	1,66	365	8,5	1,41	1,39	249	4,3	1,21	1,21	215	3,3
TEC 7.4	VI	MAX	925	4,64	3,63	815	20,7	4,02	3,37	709	16,1	2,96	2,96	526	9,4	2,44	2,44	437	6,7
	V		840	4,30	3,35	755	18,2	3,74	3,11	659	14,1	2,73	2,73	485	8,2	2,25	2,25	402	5,8
	IV	MED	735	3,86	2,98	678	15,0	3,36	2,77	592	11,7	2,43	2,43	432	6,7	2,00	2,00	358	4,7
	III		630	3,40	2,60	597	12,0	2,96	2,42	521	9,4	2,12	2,12	377	5,2	1,75	1,75	313	3,7
	II	MIN	535	2,98	2,27	521	9,4	2,60	2,11	456	7,4	1,86	1,86	329	4,1	1,53	1,53	272	2,9
	I		445	2,54	1,92	444	7,1	2,22	1,78	389	5,6	1,51	1,50	267	2,8	1,30	1,30	230	2,2
TEC 8.4	VI	MAX	1200	5,32	4,32	937	23,2	4,58	4,02	810	17,8	3,51	3,51	626	11,2	2,87	2,87	516	7,9
	V		1100	4,99	4,02	879	20,7	4,29	3,74	759	15,8	3,27	3,27	583	9,9	2,67	2,67	480	6,8
	IV	MED	1020	4,73	3,79	831	18,7	4,07	3,53	717	14,4	3,08	3,08	547	8,8	2,53	2,53	452	6,3
	III		815	3,98	3,14	698	13,9	3,43	2,92	604	10,6	2,57	2,57	456	6,5	2,11	2,11	377	4,5
	II	MIN	655	3,35	2,62	587	10,3	2,90	2,43	509	7,9	2,14	2,14	378	4,7	1,76	1,76	313	3,2
	I		510	2,72	2,09	476	7,0	2,36	1,94	415	5,4	1,70	1,70	301	3,1	1,40	1,40	249	2,2
TEC 9.4	VI	MAX	1500	6,22	5,14	1101	17,1	5,33	4,78	948	13,1	4,16	4,16	746	8,5	3,39	3,39	614	5,9
	V		1365	5,85	4,80	1032	15,3	5,02	4,47	889	11,7	3,90	3,90	697	7,5	3,18	3,18	573	5,3
	IV	MED	1210	5,38	4,37	948	13,1	4,62	4,06	817	10,1	3,55	3,55	633	6,3	2,90	2,90	521	4,4
	III		980	4,58	3,67	807	9,9	3,95	3,41	698	7,6	2,98	2,98	531	4,7	2,44	2,44	439	3,3
	II	MIN	830	4,03	3,18	709	7,9	3,48	2,96	614	6,1	2,61	2,61	464	3,7	2,14	2,14	384	2,6
	I		735	3,66	2,87	643	6,7	3,16	2,67	557	5,1	2,35	2,35	418	3,1	1,93	1,93	346	2,2

LEGEND

- WT = Water temperature
- Pc = Cooling total emission
- Ps = Cooling sensible emission
- Qw = Water flow
- Dp(c) = Water pressure drop
- Speed = Fan speed
- MAX = High speed
- MED = Medium speed
- MIN = Low speed
- Qv = Air flow

Heating emission of 3 row coil

Entering air temperature: 20°C

MODEL	Speed		WT: 70/60 °C				WT: 60/50 °C			WT: 50/40 °C			WT: 50/45 °C			WT: 45/40 °C		
			Qv	Ph	Qw	Dp(c)	Ph	Qw	Dp(c)	Ph	Qw	Dp(c)	Ph	Qw	Dp(c)	Ph	Qw	Dp(c)
			m³/h	kW	l/h	kPa	kW	l/h	kPa	kW	l/h	kPa	kW	l/h	kPa	kW	l/h	kPa
TEC 1.3	VI	MAX	220	2,42	208	2,4	1,83	157	1,5	1,25	108	0,8	1,48	255	3,7	1,19	205	2,5
	V		195	2,18	187	2,0	1,66	143	1,3	1,13	97	0,7	1,33	229	3,1	1,07	184	2,1
	IV	MED	175	1,99	171	1,7	1,51	130	1,1	1,03	89	0,6	1,21	208	2,6	0,98	169	1,8
	III		150	1,75	151	1,4	1,33	114	0,9	0,91	78	0,5	1,07	184	2,1	0,86	148	1,4
	II		125	1,53	132	1,1	1,17	101	0,7	0,80	69	0,4	0,94	162	1,6	0,76	131	1,1
	I	MIN	105	1,31	113	0,8	1,00	86	0,5	0,68	58	0,3	0,80	138	1,2	0,64	110	0,9
TEC 2.3	VI		340	3,89	335	7,5	2,97	255	4,8	2,05	176	2,6	2,38	409	11,2	1,92	330	7,9
	V	MAX	295	3,44	296	6,0	2,63	226	3,9	1,82	157	2,1	2,10	361	9,1	1,70	292	6,4
	IV		250	3,00	258	4,7	2,30	198	3,0	1,59	137	1,6	1,84	316	7,1	1,49	256	5,0
	III	MED	220	2,70	232	3,9	2,07	178	2,5	1,43	123	1,4	1,65	284	5,9	1,34	230	4,2
	II		170	2,14	184	2,6	1,64	141	1,7	1,14	98	0,9	1,31	225	3,9	1,06	182	2,8
	I	MIN	145	1,90	163	2,1	1,46	126	1,4	1,01	87	0,7	1,16	200	3,2	0,94	162	2,2
TEC 3.3	VI		440	5,52	475	19,8	4,24	365	12,8	2,96	255	7,0	3,37	580	29,8	2,74	471	21,0
	V	MAX	385	4,92	423	16,1	3,78	325	10,5	2,64	227	5,8	3,00	516	24,3	2,44	420	17,1
	IV		325	4,24	365	12,4	3,26	280	8,1	2,28	196	4,5	2,59	445	18,7	2,10	361	13,2
	III	MED	270	3,61	310	9,4	2,78	239	6,1	1,95	168	3,4	2,21	380	14,1	1,79	308	10,0
	II	MIN	235	3,14	270	7,3	2,42	208	4,8	1,70	146	2,6	1,92	330	11,0	1,56	268	7,8
	I		185	2,54	218	5,1	1,96	169	3,3	1,38	119	1,8	1,55	267	7,6	1,26	217	5,4
TEC 4.3	VI		570	6,87	591	29,1	5,27	453	18,8	3,67	316	10,3	4,20	722	43,8	3,41	587	30,8
	V	MAX	485	6,00	516	22,9	4,60	396	14,8	3,21	276	8,1	3,66	630	34,4	2,97	511	24,3
	IV		400	5,08	437	17,1	3,90	335	11,1	2,73	235	6,1	3,10	533	25,7	2,52	433	18,2
	III	MED	335	4,36	375	13,1	3,36	289	8,5	2,36	203	4,7	2,68	461	19,9	2,18	375	14,0
	II	MIN	265	3,51	302	8,9	2,70	232	5,8	1,89	163	3,2	2,14	368	13,4	1,74	299	9,5
	I		185	2,51	216	5,0	1,94	167	3,2	1,36	117	1,8	1,54	265	7,5	1,25	215	5,3
TEC 5.3	VI	MAX	650	7,57	651	13,5	5,81	500	8,7	4,04	347	4,7	4,62	795	20,2	3,75	645	14,2
	V		545	6,54	562	10,4	5,02	432	6,7	3,49	300	3,7	3,99	686	15,6	3,24	557	11,0
	IV	MED	495	6,04	519	9,0	4,64	399	5,9	3,23	278	3,2	3,69	635	13,6	3,00	516	9,6
	III		420	5,26	452	7,1	4,04	347	4,6	2,82	243	2,5	3,21	552	10,6	2,61	449	7,5
	II	MIN	315	4,07	350	4,5	3,13	269	2,9	2,19	188	1,6	2,49	428	6,8	2,02	347	4,8
	I		250	3,32	286	3,2	2,56	220	2,1	1,79	154	1,1	2,03	349	4,8	1,65	284	3,4
TEC 6.3	VI		830	9,22	793	19,0	7,06	607	12,3	4,91	422	6,7	5,63	968	28,6	4,56	784	20,1
	V	MAX	760	8,61	740	16,9	6,59	567	10,9	4,58	394	5,9	5,26	905	25,3	4,26	733	17,8
	IV		680	7,87	677	14,4	6,03	519	9,3	4,20	361	5,1	4,81	827	21,7	3,90	671	15,2
	III	MED	590	6,96	599	11,6	5,34	459	7,5	3,71	319	4,1	4,25	731	17,4	3,45	593	12,3
	II		505	6,15	529	9,3	4,72	406	6,0	3,29	283	3,3	3,76	647	14,0	3,05	525	9,9
	I	MIN	415	5,17	445	6,9	3,97	341	4,4	2,77	238	2,4	3,15	542	10,3	2,56	440	7,3
TEC 7.3	VI	MAX	925	10,55	907	28,1	8,10	697	18,2	5,64	485	10,0	6,44	1108	42,2	5,23	900	29,7
	V		840	9,76	839	24,5	7,49	644	15,8	5,22	449	8,7	5,96	1025	36,8	4,83	831	25,9
	IV	MED	735	8,73	751	20,1	6,71	577	13,0	4,68	402	7,2	5,33	917	30,3	4,33	745	21,3
	III		630	7,67	660	16,0	5,93	510	10,5	4,15	357	5,8	4,71	810	24,4	3,83	659	17,2
	II	MIN	535	6,72	578	12,7	5,17	445	8,3	3,62	311	4,5	4,11	707	19,1	3,34	574	13,5
	I		445	5,71	491	9,5	4,39	378	6,2	3,08	265	3,4	3,49	600	14,3	2,83	487	10,1
TEC 8.3	VI	MAX	1200	13,25	1140	18,5	10,13	871	11,9	7,01	603	6,5	8,09	1391	27,9	6,55	1127	19,6
	V		1100	12,36	1063	16,4	9,45	813	10,6	6,55	563	5,7	7,55	1299	24,7	6,11	1051	17,3
	IV	MED	1020	11,63	1000	14,7	8,90	765	9,5	6,17	531	5,2	7,10	1221	22,2	5,75	989	15,6
	III		815	9,67	832	10,6	7,40	636	6,9	5,14	442	3,7	5,90	1015	16,0	4,78	822	11,3
	II	MIN	655	8,11	697	7,8	6,22	535	5,1	4,33	372	2,8	4,96	853	11,8	4,02	691	8,3
	I		510	6,49	558	5,3	4,98	428	3,4	3,47	298	1,9	3,97	683	7,9	3,22	554	5,6
TEC 9.3	VI	MAX	1500	15,74	1354	25,1	12,03	1035	16,1	8,31	715	8,7	9,61	1653	37,8	7,78	1338	26,5
	V		1365	14,70	1264	22,3	11,23	966	14,3	7,77	668	7,7	8,98	1545	33,5	7,26	1249	23,5
	IV	MED	1210	13,39	1152	18,9	10,24	881	12,1	7,09	610	6,6	8,18	1407	28,4	6,62	1139	19,9
	III		980	11,29	971	14,0	8,64	743	9,0	5,99	515	4,9	6,89	1185	21,0	5,58	960	14,8
	II	MIN	830	9,82	845	11,0	7,52	647	7,1	5,22	449	3,8	6,00	1032	16,5	4,86	836	11,6
	I		735	8,87	763	9,2	6,85	589	6,0	4,76	409	3,3	5,46	939	13,9	4,42	760	9,8

LEGEND

- WT = Water temperature
- Ph = Emission
- Qw = Water flow
- Dp(c) = Water pressure drop
- Speed = Fan speed
- MAX = High speed
- MED = Medium speed
- MIN = Low speed
- Qv = Air flow

Heating emission of 4 row coil

Entering air temperature: 20°C

MODEL	Speed		WT: 70/60 °C				WT: 60/50 °C			WT: 50/40 °C			WT: 50/45 °C			WT: 45/40 °C		
			Qv	Ph	Qw	Dp(c)	Ph	Qw	Dp(c)	Ph	Qw	Dp(c)	Ph	Qw	Dp(c)	Ph	Qw	Dp(c)
			m³/h	kW	l/h	kPa	kW	l/h	kPa	kW	l/h	kPa	kW	l/h	kPa	kW	l/h	kPa
TEC 1.4	VI	MAX	220	2,63	226	4,9	2,00	172	3,1	1,38	119	1,7	1,60	275	7,3	1,30	224	5,1
	V		195	2,36	203	4,0	1,80	155	2,6	1,24	107	1,4	1,44	248	6,1	1,17	201	4,3
	IV	MED	175	2,15	185	3,4	1,64	141	2,2	1,14	98	1,2	1,32	227	5,2	1,06	182	3,6
	III		150	1,86	160	2,7	1,43	123	1,7	0,99	85	0,9	1,14	196	4,0	0,92	158	2,8
	II		125	1,62	139	2,1	1,24	107	1,3	0,86	74	0,7	0,99	170	3,1	0,80	138	2,2
	I	MIN	105	1,38	119	1,6	1,06	91	1,0	0,73	63	0,5	0,84	144	2,4	0,68	117	1,7
TEC 2.4	VI		340	4,19	360	14,0	3,22	277	9,0	2,24	193	4,9	2,56	440	21,0	2,08	358	14,8
	V	MAX	295	3,69	317	11,1	2,83	243	7,2	1,97	169	3,9	2,25	387	16,7	1,83	315	11,8
	IV		250	3,22	277	8,7	2,47	212	5,7	1,72	148	3,1	1,97	339	13,2	1,60	275	9,3
	III	MED	220	2,88	248	7,2	2,21	190	4,7	1,54	132	2,6	1,76	303	10,8	1,43	246	7,6
	II		170	2,24	193	4,6	1,73	149	3,0	1,21	104	1,7	1,37	236	7,0	1,11	191	4,9
	I	MIN	145	1,98	170	3,7	1,53	132	2,4	1,07	92	1,3	1,21	208	5,6	0,99	170	4,0
TEC 3.4	VI		440	5,80	499	10,8	4,46	384	7,0	3,12	268	3,9	3,55	611	16,3	2,88	495	11,5
	V	MAX	385	5,14	442	8,7	3,96	341	5,7	2,77	238	3,1	3,14	540	13,2	2,56	440	9,3
	IV		325	4,40	378	6,6	3,39	292	4,3	2,38	205	2,4	2,69	463	10,0	2,19	377	7,1
	III	MED	270	3,73	321	5,0	2,87	247	3,2	2,02	174	1,8	2,28	392	7,5	1,85	318	5,3
	II	MIN	235	3,23	278	3,9	2,49	214	2,5	1,75	151	1,4	1,98	341	5,8	1,61	277	4,1
	I		185	2,60	224	2,6	2,01	173	1,7	1,41	121	1,0	1,59	273	4,0	1,30	224	2,8
TEC 4.4	VI		570	7,30	628	15,4	5,60	482	10,0	3,90	335	5,5	4,46	767	23,2	3,62	623	16,4
	V	MAX	485	6,33	544	12,0	4,86	418	7,8	3,39	292	4,3	3,87	666	18,1	3,14	540	12,8
	IV		400	5,32	458	8,9	4,09	352	5,8	2,86	246	3,2	3,25	559	13,3	2,64	454	9,4
	III	MED	335	4,56	392	6,8	3,51	302	4,4	2,46	212	2,4	2,79	480	10,2	2,27	390	7,2
	II	MIN	265	3,62	311	4,5	2,79	240	2,9	1,96	169	1,6	2,21	380	6,8	1,80	310	4,8
	I		185	2,57	221	2,5	1,99	171	1,6	1,40	120	0,9	1,57	270	3,7	1,28	220	2,6
TEC 5.4	VI	MAX	650	8,07	694	23,7	6,21	534	15,4	4,34	373	8,5	4,93	848	35,7	4,01	690	25,2
	V		545	6,97	599	18,3	5,36	461	11,9	3,76	323	6,6	4,26	733	27,6	3,46	595	19,5
	IV	MED	495	6,37	548	15,6	4,90	421	10,2	3,44	296	5,6	3,89	669	23,5	3,16	544	16,6
	III		420	5,51	474	12,1	4,24	365	7,9	2,97	255	4,4	3,36	578	18,2	2,74	471	12,9
	II	MIN	315	4,23	364	7,6	3,26	280	5,0	2,29	197	2,8	2,58	444	11,4	2,10	361	8,1
	I		250	3,44	296	5,3	2,65	228	3,4	1,87	161	1,9	2,10	361	7,9	1,71	294	5,6
TEC 6.4	VI		830	10,68	918	34,1	8,22	707	22,2	5,75	495	12,2	6,53	1123	51,4	5,31	913	36,3
	V	MAX	760	9,90	851	29,9	7,62	655	19,4	5,34	459	10,7	6,05	1041	44,9	4,92	846	31,8
	IV		680	8,98	772	25,2	6,92	595	16,4	4,85	417	9,1	5,49	944	37,9	4,46	767	26,8
	III	MED	590	7,85	675	19,8	6,05	520	12,9	4,24	365	7,2	4,80	826	29,9	3,90	671	21,1
	II		505	6,81	586	15,5	5,25	452	10,1	3,69	317	5,6	4,17	717	23,3	3,39	583	16,5
	I	MIN	415	5,66	487	11,2	4,37	376	7,3	3,07	264	4,1	3,46	595	16,8	2,82	485	11,9
TEC 7.4	VI	MAX	925	11,26	968	21,9	8,65	744	14,2	6,05	520	7,8	6,88	1183	32,8	5,59	961	23,2
	V		840	10,38	893	18,9	7,98	686	12,3	5,58	480	6,8	6,34	1090	28,5	5,15	886	20,1
	IV	MED	735	9,30	800	15,6	7,16	616	10,2	5,01	431	5,6	5,68	977	23,5	4,62	795	16,6
	III		630	8,12	698	12,3	6,25	538	8,0	4,38	377	4,4	4,96	853	18,5	4,03	693	13,1
	II	MIN	535	7,02	604	9,5	5,41	465	6,2	3,79	326	3,4	4,29	738	14,3	3,49	600	10,1
	I		445	5,93	510	7,1	4,57	393	4,6	3,21	276	2,6	3,63	624	10,6	2,95	507	7,5
TEC 8.4	VI	MAX	1200	14,36	1235	29,3	11,00	946	18,9	7,63	656	10,3	8,77	1508	44,1	7,11	1223	31,0
	V		1100	13,34	1147	25,7	10,22	879	16,6	7,10	611	9,0	8,15	1402	38,9	6,60	1135	27,4
	IV	MED	1020	12,52	1077	23,0	9,60	826	14,9	6,67	574	8,1	7,65	1316	34,7	6,20	1066	24,5
	III		815	10,37	892	16,6	7,96	685	10,8	5,54	476	5,9	6,34	1090	24,8	5,14	884	17,6
	II	MIN	655	8,55	735	11,9	6,57	565	7,6	4,58	394	4,1	5,23	900	17,8	4,24	729	12,6
	I		510	6,78	583	7,9	5,22	449	5,0	3,65	314	2,9	4,15	714	11,9	3,37	580	8,3
TEC 9.4	VI	MAX	1500	17,23	1482	22,5	13,18	1133	14,5	9,13	785	7,8	10,53	1811	33,8	8,52	1465	23,7
	V		1365	16,02	1378	19,8	12,26	1054	12,7	8,50	731	6,9	9,79	1684	29,7	7,93	1364	20,9
	IV	MED	1210	14,52	1249	16,6	11,12	956	10,7	7,71	663	5,8	8,87	1526	25,0	7,18	1235	17,6
	III		980	12,13	1043	12,1	9,30	800	7,8	6,46	556	4,3	7,41	1275	18,2	6,01	1034	12,8
	II	MIN	830	10,55	907	9,5	8,09	696	6,1	5,63	484	3,4	6,44	1108	14,3	5,23	900	10,0
	I		735	9,47	814	7,8	7,27	625	5,1	5,07	436	2,8	5,79	996	11,8	4,70	808	8,3

LEGEND

- WT = Water temperature Speed = Fan speed
- Ph = Emission MAX = High speed
- Qw = Water flow MED = Medium speed
- Dp(c) = Water pressure drop MIN = Low speed
- Qv = Air flow

Heating emission of 1 row additional coil

Entering air temperature: 20°C

MODEL	Speed		WT: 80/70 °C				WT: 75/65 °C				WT: 70/60 °C				WT: 65/55 °C				WT: 60/50 °C				WT: 55/45 °C			
			Qv	Ph	Qw	Dp(c)	Ph	Qw	Dp(c)	Ph	Qw	Dp(c)	Ph	Qw	Dp(c)	Ph	Qw	Dp(c)	Ph	Qw	Dp(c)	Ph	Qw	Dp(c)		
			m³/h	kW	l/h	kPa	kW	l/h	kPa	kW	l/h	kPa	kW	l/h	kPa	kW	l/h	kPa	kW	l/h	kPa	kW	l/h	kPa		
TEC 1	VI	MAX	220	1,32	114	2,4	1,18	101	2,0	1,04	89	1,6	0,91	78	1,3	0,77	66	1,0	0,63	54	0,7					
	V		195	1,21	104	2,1	1,08	93	1,7	0,96	83	1,4	0,83	71	1,1	0,71	61	0,9	0,58	50	0,6					
	IV	MED	175	1,12	96	1,8	1,00	86	1,5	0,89	77	1,2	0,77	66	1,0	0,65	56	0,7	0,54	46	0,5					
	III		150	1,00	86	1,5	0,90	77	1,2	0,79	68	1,0	0,69	59	0,8	0,59	51	0,6	0,48	41	0,4					
	II		125	0,90	77	1,2	0,81	70	1,0	0,71	61	0,8	0,62	53	0,7	0,53	46	0,5	0,44	38	0,4					
	I	MIN	105	0,79	68	1,0	0,71	61	0,8	0,63	54	0,7	0,55	47	0,5	0,47	40	0,4	0,39	34	0,3					
TEC 2	VI		340	2,11	181	6,6	1,90	163	5,6	1,68	144	4,6	1,47	126	3,7	1,26	108	2,8	1,05	90	2,1					
	V	MAX	295	1,90	163	5,5	1,71	147	4,7	1,52	131	3,8	1,33	114	3,1	1,14	98	2,4	0,95	82	1,8					
	IV		250	1,70	146	4,5	1,53	132	3,8	1,36	117	3,2	1,19	102	2,5	1,02	88	2,0	0,85	73	1,4					
	III	MED	220	1,56	134	3,9	1,41	121	3,3	1,25	108	2,7	1,09	94	2,2	0,94	81	1,7	0,78	67	1,2					
	II		170	1,30	112	2,8	1,17	101	2,4	1,04	89	2,0	0,91	78	1,6	0,78	67	1,2	0,65	56	0,9					
	I	MIN	145	1,18	101	2,4	1,06	91	2,0	0,94	81	1,7	0,83	71	1,3	0,71	61	1,0	0,59	51	0,8					
TEC 3	VI		440	3,08	265	16,2	2,78	239	13,7	2,48	213	11,4	2,18	187	9,2	1,88	162	7,2	1,57	135	5,4					
	V	MAX	385	2,81	242	13,8	2,54	218	11,7	2,26	194	9,7	1,99	171	7,8	1,71	147	6,1	1,44	124	4,6					
	IV		325	2,49	214	11,1	2,25	194	9,4	2,00	172	7,8	1,76	151	6,3	1,52	131	4,9	1,28	110	3,7					
	III	MED	270	2,20	189	9,0	1,98	170	7,6	1,77	152	6,3	1,56	134	5,1	1,34	115	4,0	1,13	97	3,0					
	II	MIN	235	1,98	170	7,4	1,78	153	6,3	1,59	137	5,2	1,40	120	4,2	1,21	104	3,3	1,02	88	2,5					
	I		185	1,68	144	5,6	1,52	131	4,7	1,35	116	3,9	1,19	102	3,2	1,03	89	2,5	0,86	74	1,9					
TEC 4	VI		570	3,68	316	22,1	3,32	286	18,7	2,96	255	15,5	2,60	224	12,5	2,24	193	9,8	1,88	162	7,3					
	V	MAX	485	3,30	284	18,2	2,97	255	15,4	2,65	228	12,8	2,33	200	10,3	2,00	172	8,1	1,68	144	6,0					
	IV		400	2,89	249	14,4	2,60	224	12,2	2,32	200	10,1	2,04	175	8,2	1,76	151	6,4	1,47	126	4,8					
	III	MED	335	2,56	220	11,7	2,31	199	9,9	2,06	177	8,2	1,81	156	6,6	1,56	134	5,2	1,31	113	3,9					
	II	MIN	265	2,15	185	8,6	1,94	167	7,3	1,73	149	6,0	1,52	131	4,9	1,31	113	3,8	1,10	95	2,9					
	I		185	1,67	144	5,5	1,50	129	4,7	1,34	115	3,9	1,18	101	3,1	1,02	88	2,5	0,86	74	1,8					
TEC 5	VI	MAX	650	4,28	368	5,6	3,85	331	4,8	3,42	294	3,9	3,00	258	3,2	2,57	221	2,4	2,14	184	1,8					
	V		545	3,79	326	4,6	3,41	293	3,8	3,03	261	3,2	2,66	229	2,6	2,28	196	2,0	1,90	163	1,5					
	IV	MED	495	3,54	304	4,0	3,18	273	3,4	2,83	243	2,8	2,48	213	2,3	2,13	183	1,8	1,78	153	1,3					
	III		420	3,16	272	3,3	2,85	245	2,8	2,53	218	2,3	2,22	191	1,9	1,90	163	1,4	1,59	137	1,1					
	II	MIN	315	2,59	223	2,3	2,33	200	2,0	2,07	178	1,6	1,82	157	1,3	1,56	134	1,0	1,30	112	0,8					
	I		250	2,20	189	1,8	1,99	171	1,5	1,77	152	1,2	1,55	133	1,0	1,33	114	0,8	1,12	96	0,6					
TEC 6	VI		830	5,05	434	7,5	4,54	390	6,4	4,04	347	5,3	3,53	304	4,2	3,03	261	3,3	2,53	218	2,4					
	V	MAX	760	4,77	410	6,8	4,29	369	5,8	3,81	328	4,8	3,33	286	3,8	2,86	246	2,9	2,38	205	2,2					
	IV		680	4,42	380	6,0	3,98	342	5,0	3,54	304	4,1	3,09	266	3,3	2,65	228	2,6	2,21	190	1,9					
	III	MED	590	3,99	343	5,0	3,59	309	4,2	3,19	274	3,5	2,79	240	2,8	2,40	206	2,1	2,00	172	1,6					
	II		505	3,59	309	4,1	3,23	278	3,5	2,87	247	2,9	2,51	216	2,3	2,16	186	1,8	1,80	155	1,3					
	I	MIN	415	3,12	268	3,2	2,81	242	2,7	2,50	215	2,3	2,19	188	1,8	1,88	162	1,4	1,57	135	1,1					
TEC 7	VI	MAX	925	5,97	513	11,9	5,38	463	10,1	4,79	412	8,3	3,53	304	5,9	3,61	310	5,2	3,03	261	3,9					
	V		840	5,59	481	10,6	5,04	433	9,0	4,49	386	7,4	3,33	286	5,3	3,39	292	4,7	2,84	244	3,5					
	IV	MED	735	5,10	439	9,0	4,59	395	7,6	4,09	352	6,3	3,09	266	4,7	3,09	266	4,0	2,59	223	3,0					
	III		630	4,58	394	7,5	4,13	355	6,3	3,68	316	5,2	2,79	240	3,9	2,78	239	3,3	2,33	200	2,5					
	II	MIN	535	4,10	353	6,1	3,69	317	5,2	3,29	283	4,3	2,51	216	3,3	2,49	214	2,7	2,09	180	2,0					
	I		445	3,60	310	4,9	3,25	280	4,1	2,89	249	3,4	2,19	188	2,5	2,19	188	2,2	1,84	158	1,6					
TEC 8	VI	MAX	1200	6,75	581	14,8	6,08	523	12,5	5,41	465	10,3	4,75	409	8,3	4,08	351	6,5	3,42	294	4,8					
	V		1100	6,37	548	13,3	5,74	494	11,3	5,11	439	9,3	4,48	385	7,5	3,85	331	5,9	3,23	278	4,4					
	IV	MED	1020	6,05	520	12,2	5,45	469	10,3	4,86	418	8,5	4,26	366	6,9	3,66	315	5,4	3,07	264	4,0					
	III		815	5,19	446	9,3	4,68	402	7,9	4,17	359	6,5	3,66	315	5,3	3,15	271	4,1	2,64	227	3,1					
	II	MIN	655	4,48	385	7,2	4,04	347	6,1	3,60	310	5,0	3,16	272	4,1	2,72	234	3,2	2,28	196	2,4					
	I		510	3,76	323	5,3	3,39	292	4,5	3,03	261	3,7	2,66	229	3,0	2,29	197	2,3	1,92	165	1,7					
TEC 9	VI	MAX	1500	7,77	668	18,9	7,00	602	16,0	6,23	536	13,2	5,46	470	10,7	4,69	403	8,3	3,93	338	6,2					
	V		1365	7,36	633	17,2	6,63	570	14,5	5,90	507	12,0	5,17	445	9,7	4,45	383	7,5	3,72	320	5,6					
	IV	MED	1210	6,81	586	15,0	6,13	527	12,7	5,46	470	10,5	4,79	412	8,5	4,12	354	6,6	3,45	297	4,9					
	III		980	5,90	507	11,7	5,32	458	9,9	4,74	408	8,2	4,15	357	6,6	3,57	307	5,1	2,99	257	3,8					
	II	MIN	830	5,26	452	9,5	4,74	408	8,1	4,22	363	6,7	3,71	319	5,4	3,19	274	4,2	2,67	230	3,1					
	I		735	4,84	416	8,2	4,37	376	7,0	3,89	335	5,8	3,41	293	4,7	2,94	253	3,6	2,46	212	2,7					

LEGEND

- WT = Water temperature
- Ph = Emission
- Qw = Water flow
- Dp(c) = Water pressure drop
- Speed = Fan speed
- MAX = High speed
- MED = Medium speed
- MIN = Low speed
- Qv = Air flow

Heating emission of 2 row additional coil

Entering air temperature: 20°C

MODEL	Speed		WT: 65/55 °C				WT: 60/50 °C			WT: 55/45 °C			WT: 50/40 °C			WT: 45/40 °C			WT: 45/35 °C		
			Qv	Ph	Qw	Dp(c)	Ph	Qw	Dp(c)	Ph	Qw	Dp(c)	Ph	Qw	Dp(c)	Ph	Qw	Dp(c)	Ph	Qw	Dp(c)
			m³/h	kW	l/h	kPa	kW	l/h	kPa	kW	l/h	kPa	kW	l/h	kPa	kW	l/h	kPa	kW	l/h	kPa
TEC 1	VI	MAX	220	1,67	144	7,1	1,44	124	5,5	1,20	103	4,1	0,97	83	2,9	0,93	160	9,1	0,74	64	1,8
	V		195	1,52	131	6,0	1,31	113	4,7	1,10	95	3,5	0,89	77	2,5	0,85	146	7,8	0,68	58	1,6
	IV	MED	175	1,40	120	5,2	1,21	104	4,1	1,01	87	3,0	0,82	71	2,1	0,78	134	6,7	0,63	54	1,3
	III		150	1,24	107	4,2	1,07	92	3,3	0,90	77	2,5	0,73	63	1,7	0,69	119	5,4	0,56	48	1,1
	II		125	1,10	95	3,4	0,95	82	2,7	0,80	69	2,0	0,65	56	1,4	0,62	107	4,4	0,50	43	0,9
	I	MIN	105	0,97	83	2,7	0,83	71	2,1	0,70	60	1,6	0,57	49	1,1	0,54	93	3,5	0,44	38	0,7
TEC 2	VI		340	2,58	222	17,9	2,23	192	14,0	1,88	162	10,6	1,53	132	7,5	1,44	248	23,1	1,18	101	4,8
	V	MAX	295	2,32	200	14,8	2,00	172	11,6	1,69	145	8,8	1,37	118	6,2	1,30	224	19,2	1,06	91	4,0
	IV		250	2,06	177	12,0	1,78	153	9,4	1,50	129	7,1	1,22	105	5,0	1,15	198	15,5	0,94	81	3,3
	III	MED	220	1,87	161	10,2	1,62	139	8,0	1,37	118	6,0	1,11	95	4,3	1,05	181	13,2	0,86	74	2,8
	II		170	1,52	131	7,1	1,32	114	5,6	1,11	95	4,2	0,91	78	3,0	0,85	146	9,1	0,70	60	1,9
	I	MIN	145	1,39	120	6,0	1,20	103	4,7	1,01	87	3,6	0,83	71	2,5	0,78	134	7,7	0,64	55	1,6
TEC 3	VI		440	3,52	303	6,3	3,04	261	5,0	2,56	220	3,7	2,00	172	2,6	1,97	339	8,2	1,59	137	1,7
	V	MAX	385	3,19	274	5,3	2,76	237	4,2	2,32	200	3,1	1,88	162	2,2	1,79	308	6,9	1,45	125	1,4
	IV		325	2,80	241	4,2	2,42	208	3,3	2,04	175	2,5	1,66	143	1,8	1,57	270	5,5	1,27	109	1,1
	III	MED	270	2,45	211	3,3	2,11	181	2,6	1,78	153	2,0	1,46	126	1,4	1,38	237	4,4	1,13	97	0,9
	II	MIN	235	2,20	189	2,8	1,90	163	2,2	1,60	138	1,6	1,30	112	1,2	1,23	212	3,6	1,00	86	0,7
	I		185	1,82	157	2,0	1,58	136	1,6	1,33	114	1,2	1,08	93	0,8	1,02	175	2,6	0,84	72	0,5
TEC 4	VI		570	4,13	355	8,4	3,56	306	6,5	2,99	257	4,9	2,42	208	3,4	2,31	397	10,8	1,86	160	2,2
	V	MAX	485	3,78	325	7,2	3,26	280	5,6	2,74	236	4,2	2,22	191	3,0	2,11	363	9,2	1,70	146	1,9
	IV		400	3,28	282	5,6	2,83	243	4,4	2,38	205	3,3	1,94	167	2,3	1,84	316	7,2	1,49	128	1,5
	III	MED	335	2,89	249	4,5	2,49	214	3,5	2,10	181	2,6	1,70	146	1,9	1,61	277	5,8	1,31	113	1,2
	II	MIN	265	2,41	207	3,2	2,08	179	2,6	1,76	151	1,9	1,43	123	1,4	1,35	232	4,2	1,10	95	0,9
	I		185	1,81	156	2,0	1,56	134	1,5	1,32	114	1,2	1,07	92	0,8	1,01	174	2,5	0,83	71	0,5
TEC 5	VI	MAX	650	5,23	450	15,6	4,52	389	12,3	3,82	329	9,3	3,11	267	6,6	2,93	504	20,2	2,41	207	4,3
	V		545	4,59	395	12,4	3,97	341	9,8	3,36	289	7,4	2,74	236	5,3	2,57	442	16,1	2,12	182	3,4
	IV	MED	495	4,26	366	10,9	3,68	316	8,6	3,11	267	6,5	2,54	218	4,6	2,38	409	14,1	1,97	169	3,0
	III		420	3,76	323	8,7	3,26	280	6,9	2,75	237	5,2	2,25	194	3,7	2,11	363	11,3	1,74	150	2,4
	II	MIN	315	3,03	261	6,0	2,62	225	4,7	2,22	191	3,6	1,82	157	2,6	1,70	292	7,7	1,41	121	1,7
	I		250	2,52	217	4,3	2,18	187	3,4	1,85	159	2,6	1,51	130	1,8	1,41	243	5,6	1,18	101	1,2
TEC 6	VI		830	6,22	535	21,2	5,38	463	16,6	4,54	390	12,5	3,70	318	8,9	3,48	599	27,4	2,86	246	5,8
	V	MAX	760	5,86	504	19,0	5,06	435	15,0	4,27	367	11,3	3,48	299	8,0	3,28	564	24,6	2,69	231	5,2
	IV		680	5,41	465	16,6	4,68	402	13,0	3,95	340	9,8	3,22	277	7,0	3,03	521	21,4	2,49	214	4,5
	III	MED	590	4,85	417	13,7	4,20	361	10,7	3,54	304	8,1	2,89	249	5,7	2,72	468	17,7	2,24	193	3,8
	II		505	4,32	372	11,2	3,74	322	8,8	3,16	272	6,6	2,58	222	4,8	2,42	416	14,4	2,00	172	3,1
	I	MIN	415	3,70	318	8,5	3,21	276	6,7	2,71	233	5,1	2,21	190	3,6	2,07	356	11,0	1,72	148	2,4
TEC 7	VI	MAX	925	7,30	628	33,3	6,32	544	26,3	5,35	460	19,9	4,37	376	14,2	4,08	702	43,1	3,40	292	9,3
	V		840	6,81	586	29,5	5,90	507	23,3	4,99	429	17,6	4,08	351	12,6	3,81	655	38,2	3,17	273	8,2
	IV	MED	735	6,17	531	24,8	5,34	459	19,6	4,52	389	14,8	3,70	318	10,6	3,45	593	32,1	2,88	248	6,9
	III		630	5,49	472	20,2	4,76	409	16,0	4,03	347	12,1	3,30	284	8,7	3,07	528	26,2	2,57	221	5,7
	II	MIN	535	4,85	417	16,3	4,21	362	12,9	3,57	307	9,8	2,92	251	7,0	2,72	468	21,1	2,27	195	4,6
	I		445	4,24	365	12,8	3,68	316	10,2	3,12	268	7,7	2,56	220	5,5	2,38	409	16,6	1,99	171	3,6
TEC 8	VI	MAX	1200	8,76	753	46,0	7,58	652	36,2	6,41	551	27,4	5,24	451	19,6	4,90	843	59,5	4,07	350	12,8
	V		1100	8,25	710	41,4	7,14	614	32,6	6,04	519	24,7	4,94	425	17,6	4,62	795	53,5	3,83	329	11,5
	IV	MED	1020	7,82	673	37,7	6,78	583	29,7	5,73	493	22,5	4,69	403	16,1	4,38	753	48,8	3,64	313	10,5
	III		815	6,65	572	28,3	5,76	495	22,3	4,87	419	16,9	3,99	343	12,1	3,72	640	36,6	3,10	267	7,9
	II	MIN	655	5,66	487	21,3	4,91	422	16,9	4,16	358	12,8	3,40	292	9,1	3,17	545	27,6	2,65	228	6,0
	I		510	4,66	401	15,1	4,04	347	12,0	3,42	294	9,1	2,81	242	6,5	2,61	449	19,6	2,19	188	4,3
TEC 9	VI	MAX	1500	10,18	875	59,9	8,81	758	47,2	7,45	641	35,7	6,08	523	25,4	-	-	-	4,72	406	16,6
	V		1365	9,59	825	53,9	8,30	714	42,5	7,02	604	32,1	5,73	493	22,9	-	-	-	4,45	383	14,9
	IV	MED	1210	8,84	760	46,8	7,65	658	36,8	6,47	556	27,8	5,29	455	19,9	-	-	-	4,10	353	13,0
	III		980	7,62	655	36,0	6,60	568	28,4	5,58	480	21,5	4,57	393	15,3	-	-	-	3,55	305	10,0
	II	MIN	830	6,74	580	29,0	5,84	502	22,9	4,94	425	17,3	4,04	347	12,4	-	-	-	3,14	270	8,1
	I		735	6,17	531	24,8	5,34	459	19,6	4,52	389	14,8	3,70	318	10,6	-	-	-	2,88	248	6,9

LEGEND

- WT = Water temperature
- Ph = Emission
- Qw = Water flow
- Dp(c) = Water pressure drop
- Speed = Fan speed
- MAX = High speed
- MED = Medium speed
- MIN = Low speed
- Qv = Air flow

**Air flow and correction factors for emission
with different available pressures**

MODEL	Speed		Qv (m³/h)							K1					K2					
			Ap (Pa)							Ap (Pa)					Ap (Pa)					
			0	10	20	30	40	50	0	10	20	30	40	50	0	10	20	30	40	50
TEC 1	VI	MAX	220	199	179	154	128	100	1,00	0,92	0,84	0,75	0,66	0,53	-	0,91	0,83	0,73	0,64	0,51
	V		195	174	152	130	102	72	1,00	0,91	0,82	0,72	0,60	-	1,00	0,90	0,80	0,71	0,58	-
	IV	MED	175	151	129	100	74	-	1,00	0,88	0,78	0,65	0,50	-	1,00	0,87	0,77	0,63	0,48	-
	III		150	123	94	69	-	-	1,00	0,85	0,69	0,54	-	-	1,00	0,84	0,67	0,52	-	-
	II		125	96	63	-	-	-	1,00	0,81	0,58	-	-	-	1,00	0,79	0,56	-	-	-
I	MIN	105	70	43	-	-	-	1,00	0,73	0,49	-	-	-	1,00	0,71	0,47	-	-	-	
TEC 2	VI		340	312	287	254	218	180	1,00	0,93	0,87	0,79	0,71	0,61	-	0,92	0,85	0,77	0,69	0,59
	V	MAX	295	260	233	195	163	117	1,00	0,90	0,83	0,72	0,63	0,48	1,00	0,89	0,81	0,70	0,61	0,45
	IV		250	218	180	145	108	-	1,00	0,89	0,77	0,65	0,51	-	1,00	0,88	0,75	0,63	0,49	-
	III	MED	220	177	135	98	-	-	1,00	0,84	0,68	0,52	-	-	1,00	0,82	0,66	0,50	-	-
	II		170	119	92	-	-	-	1,00	0,75	0,62	-	-	-	1,00	0,73	0,60	-	-	-
I	MIN	145	83	45	-	-	-	1,00	0,64	0,37	-	-	-	1,00	0,62	0,35	-	-	-	
TEC 3	VI		440	413	380	348	314	270	1,00	0,95	0,88	0,83	0,76	0,68	-	0,94	0,87	0,81	0,75	0,66
	V	MAX	385	351	320	287	249	208	1,00	0,93	0,86	0,79	0,71	0,62	1,00	0,92	0,84	0,77	0,69	0,60
	IV		325	284	244	209	179	-	1,00	0,89	0,79	0,71	0,63	-	1,00	0,88	0,78	0,69	0,61	-
	III	MED	270	212	178	141	-	-	1,00	1,17	0,72	0,60	-	-	1,00	1,20	0,70	0,58	-	-
	II	MIN	235	177	138	-	-	-	1,00	0,79	0,66	-	-	-	1,00	0,78	0,64	-	-	-
I		185	125	75	-	-	-	1,00	0,73	0,48	-	-	-	1,00	0,72	0,46	-	-	-	
TEC 4	VI		570	527	472	432	381	314	1,00	0,94	0,86	0,80	0,73	0,63	-	0,93	0,84	0,78	0,71	0,61
	V	MAX	485	437	387	340	282	230	1,00	0,92	0,83	0,75	0,65	0,55	1,00	0,91	0,82	0,74	0,63	0,53
	IV		400	343	293	238	187	-	1,00	0,88	0,78	0,67	0,55	-	1,00	0,87	0,76	0,65	0,53	-
	III	MED	335	275	215	159	-	-	1,00	0,85	0,71	0,56	-	-	1,00	0,83	0,69	0,54	-	-
	II	MIN	265	176	124	-	-	-	1,00	0,72	0,55	-	-	-	1,00	0,70	0,53	-	-	-
I		185	78	-	-	-	-	1,00	0,50	-	-	-	-	1,00	0,48	-	-	-	-	
TEC 5	VI	MAX	650	590	532	472	405	341	1,00	0,92	0,85	0,77	0,69	0,60	-	0,91	0,83	0,76	0,67	0,58
	V		545	480	413	341	283	230	1,00	0,90	0,80	0,69	0,60	-	1,00	0,89	0,78	0,67	0,58	-
	IV	MED	495	420	343	275	226	-	1,00	0,87	0,75	0,63	0,54	-	1,00	0,86	0,73	0,61	0,52	-
	III		420	333	247	192	-	-	1,00	0,83	0,66	0,54	-	-	1,00	0,81	0,64	0,52	-	-
	II	MIN	315	205	135	-	-	-	1,00	0,71	0,51	-	-	-	1,00	0,69	0,49	-	-	-
I		250	150	-	-	-	-	1,00	0,67	-	-	-	-	1,00	0,65	-	-	-	-	
TEC 6	VI		830	771	719	648	585	521	1,00	0,94	0,89	0,82	0,76	0,69	-	0,93	0,87	0,80	0,74	0,67
	V	MAX	760	705	639	581	514	446	1,00	0,94	0,87	0,81	0,73	0,66	1,00	0,93	0,85	0,79	0,72	0,64
	IV		680	592	555	503	436	360	1,00	0,89	0,85	0,79	0,70	0,61	1,00	0,88	0,83	0,77	0,69	0,59
	III	MED	590	524	466	411	347	282	1,00	0,91	0,83	0,75	0,66	0,56	1,00	0,89	0,81	0,73	0,64	0,54
	II		505	430	362	298	244	-	1,00	0,88	0,77	0,66	0,56	-	1,00	0,86	0,75	0,64	0,54	-
I	MIN	415	332	271	-	-	-	1,00	0,83	0,71	-	-	-	1,00	0,82	0,69	-	-	-	
TEC 7	VI	MAX	925	873	814	748	673	593	1,00	0,95	0,90	0,84	0,78	0,70	-	0,95	0,89	0,83	0,76	0,69
	V		840	794	775	676	609	542	1,00	0,95	0,93	0,84	0,77	0,71	1,00	0,95	0,93	0,82	0,76	0,69
	IV	MED	735	686	633	573	512	443	1,00	0,94	0,88	0,82	0,75	0,67	1,00	0,94	0,87	0,80	0,73	0,65
	III		630	580	522	470	405	352	1,00	0,93	0,86	0,79	0,71	0,63	1,00	0,92	0,84	0,77	0,69	0,61
	II	MIN	535	471	415	359	302	-	1,00	0,90	0,81	0,73	0,64	-	1,00	0,89	0,80	0,71	0,62	-
I		445	373	318	254	-	-	1,00	0,87	0,77	0,65	-	-	1,00	0,85	0,75	0,63	-	-	
TEC 8	VI	MAX	1200	1138	1076	1020	952	869	1,00	0,96	0,91	0,87	0,83	0,77	-	0,95	0,90	0,86	0,81	0,75
	V		1100	1043	975	907	834	751	1,00	0,95	0,90	0,85	0,80	0,74	1,00	0,95	0,89	0,84	0,78	0,72
	IV	MED	1020	946	885	815	736	668	1,00	0,94	0,89	0,83	0,77	0,72	1,00	0,93	0,88	0,82	0,75	0,70
	III		815	736	668	589	526	452	1,00	0,92	0,85	0,77	0,71	0,63	1,00	0,91	0,83	0,75	0,69	0,61
	II	MIN	655	556	487	385	312	-	1,00	0,87	0,79	0,66	0,56	-	1,00	0,86	0,77	0,64	0,54	-
I		510	406	291	208	-	-	1,00	0,83	0,65	0,49	-	-	1,00	0,81	0,63	0,47	-	-	
TEC 9	VI	MAX	1500	1438	1387	1315	1233	1063	1,00	0,96	0,94	0,90	0,85	0,76	-	0,96	0,93	0,88	0,84	0,74
	V		1365	1312	1259	1190	1127	931	1,00	0,97	0,93	0,89	0,85	0,74	1,00	0,96	0,93	0,88	0,84	0,72
	IV	MED	1210	1167	1114	1055	964	803	1,00	0,97	0,93	0,89	0,83	0,72	1,00	0,97	0,92	0,88	0,82	0,70
	III		980	927	873	799	724	597	1,00	0,95	0,91	0,85	0,79	0,68	1,00	0,95	0,90	0,83	0,77	0,66
	II	MIN	830	761	702	633	575	447	1,00	0,93	0,87	0,80	0,75	0,62	1,00	0,92	0,86	0,79	0,73	0,60
I		735	662	599	525	457	-	1,00	0,91	0,85	0,77	0,69	-	1,00	0,91	0,83	0,75	0,67	-	

LEGEND

Qv = Air flow

K1 = Correction factors for Total cooling emission

K2 = Correction factors for Sensible cooling emission and Heating emission

Ap = Available pressure

Speed = Fan speed

MAX = High speed

MED = Medium speed

MIN = Low speed

Water pressure drop

3 row coil

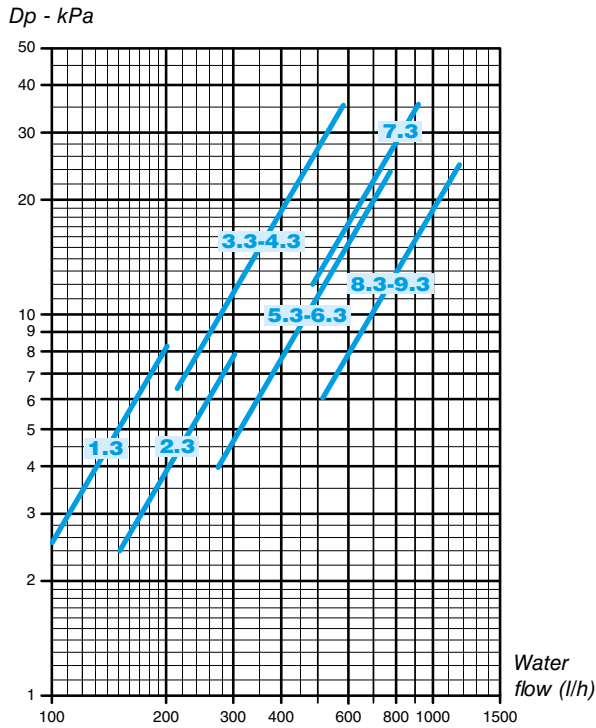

4 row coil

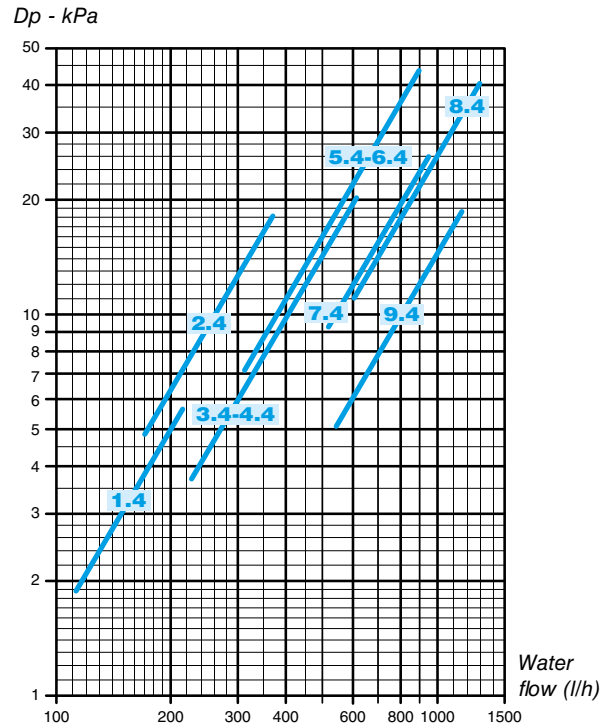

The water pressure drop figures refer to a mean water temperature of **10°C**; for different temperatures, multiply the pressure drop figures by the correction factors **K**.

°C	20	30	40	50	60	70	80
K	0,94	0,90	0,86	0,82	0,78	0,74	0,70

1 row additional coil

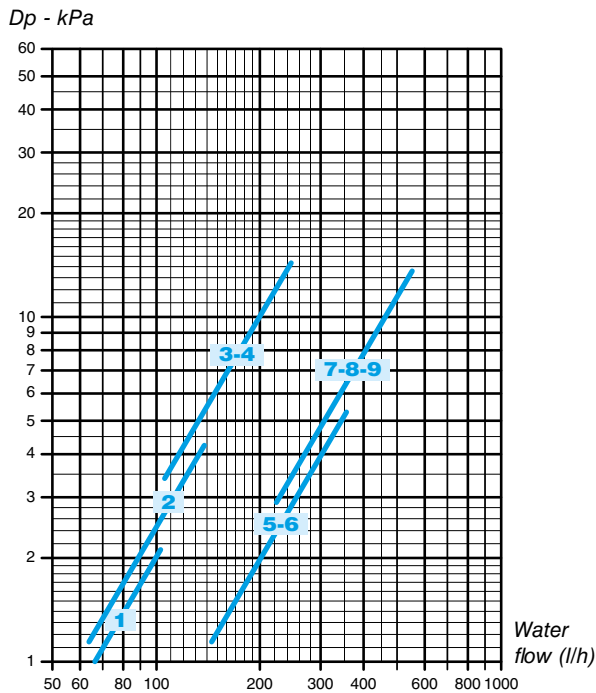

2 row additional coil

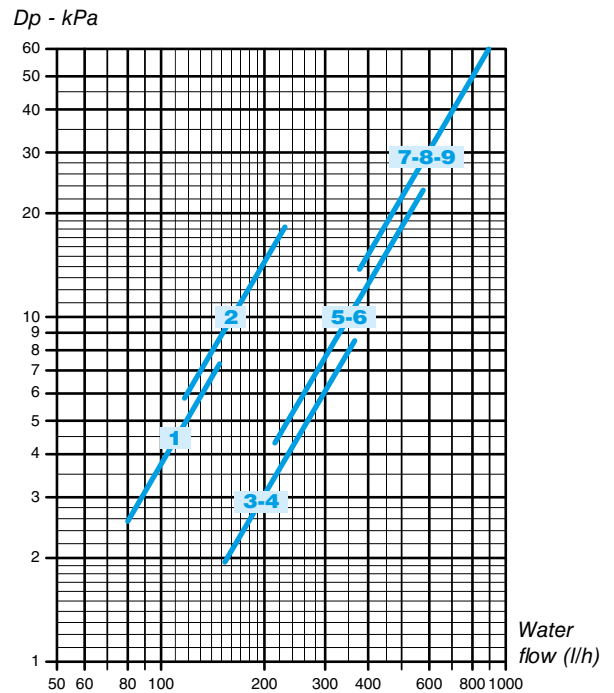

The water pressure drop figures refer to a mean water temperature of **60°C**; for different temperatures, multiply the pressure drop figures by the correction factors **K**.

°C	40	50	70	80
K	1,12	1,06	0,94	0,88

VBP
main coil 3 way valve

Control valve kit:
3 way valve, ON-OFF,
with electric motor and mounting kit
with micrometric lockshield valve.

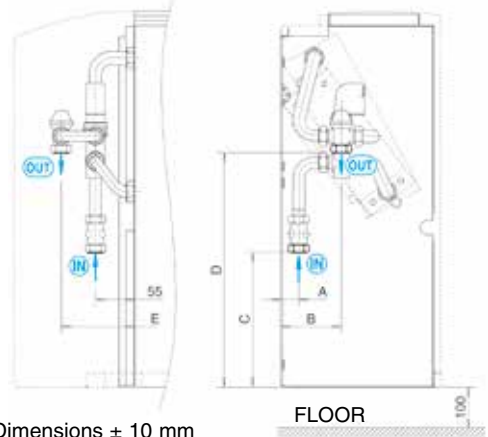
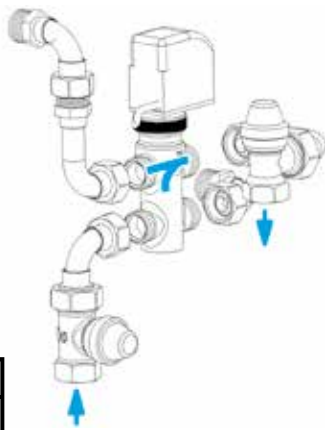

Dimensions ± 10 mm

VERSION	TEC
MODEL	CV - CH - CVB - NC

Mod.	Dimensions (mm)					Valve			Micrometric lockshield valve			Code	
	A	B	C	D	E	DN	(Ø)	Kvs	DN	(Ø)	Kvs	FITTED	NOT FITTED
1 ÷ 5	25	85	190	290	105	15	1/2"	1,6	15	1/2" F	2	9066561H	9066560H
6 - 7	25	85	190	290	105	20	3/4"	2,5	15	1/2" F	2	9060471H	9060474H
8 - 9	50	120	185	290	105	20	3/4"	2,5	15	1/2" F	2	9060471H	9060474H

VBA
additional coil 3 way valve

Control valve kit:
3 way valve, ON-OFF,
with electric motor and mounting kit
with micrometric lockshield valve.

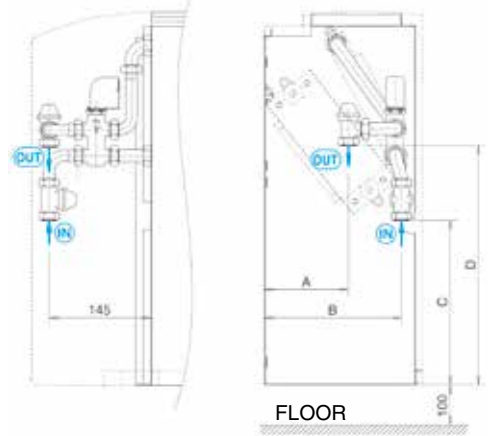
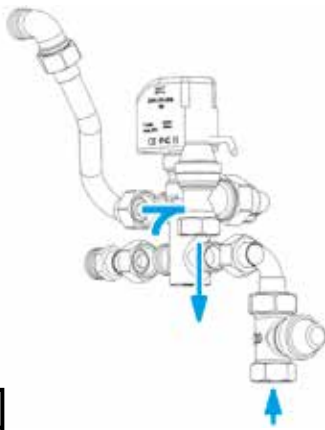

Dimensions ± 10 mm

VERSION	TEC
MODEL	CV - CH - CVB - NC

Mod.	Dimensions (mm)				Valve			Micrometric lockshield valve			Code	
	A	B	C	D	DN	(Ø)	Kvs	DN	(Ø)	Kvs	FITTED	NOT FITTED
1 ÷ 7	120	195	240	340	15	1/2"	1,6	15	1/2" F	2	9060472H	9060475H
8 - 9	135	200	235	330	15	1/2"	1,6	15	1/2" F	2	9060472H	9060475H

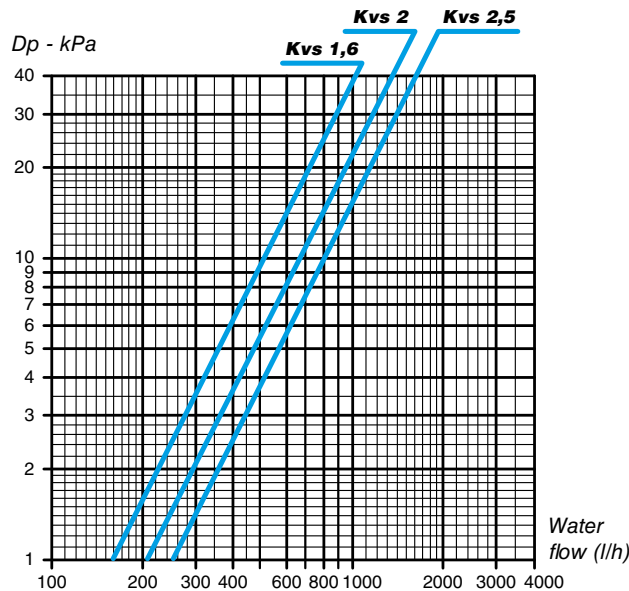

Accessories for TEC

VS simplified kit for 3 way valve (concealed model only)

3 way valve, (ON-OFF)
with electric motor and mounting kit.
Valve with flat connection
without micrometric lockshield valve.

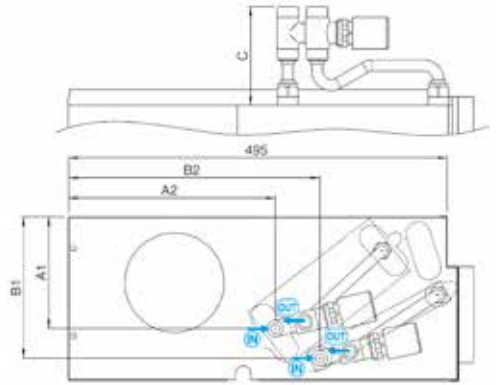
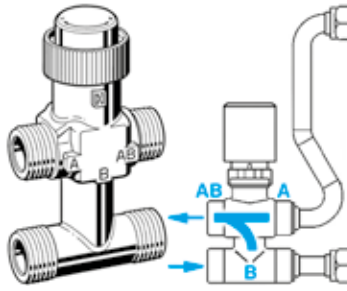

Dimensions ± 10 mm

VERSION	TEC
MODEL	NC

MOD.	Dimensions (mm)					MAIN				ADDITIONAL					
	MAIN		ADDITIONAL		C	Valve			Code		Valve			Code	
	A1	A2	B1	B2		DN	(Ø)	Kvs	FITTED	NOT FITTED	DN	(Ø)	Kvs	FITTED	NOT FITTED
1 ÷ 5	152	270	185	330	116	15	1/2"	1,6	9066571H	9066570H	15	1/2"	1,6	9060483H	9060480H
6 - 7	152	268	185	330	124	20	3/4"	2,5	9060484H	9060481H					
8 - 9	177	270	210	327	124	20	3/4"	2,5	9060484H	9060481H					

V2 2 way valve for main and additional coil

Control valve kit:
2 way valve, ON-OFF,
with electric motor and mounting kit.

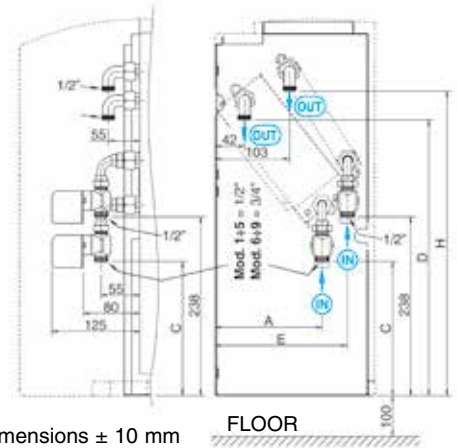
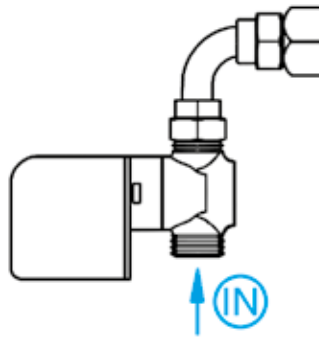

Dimensions ± 10 mm

VERSION	TEC
MODEL	CV - CH - CVB - NC

MOD.	Dimensions (mm)					MAIN				ADDITIONAL					
	MAIN		ADDITIONAL		H	Valve			Code		Valve			Code	
	A	C	D	E		DN	(Ø)	Kvs	FITTED	NOT FITTED	DN	(Ø)	Kvs	FITTED	NOT FITTED
1 ÷ 5	149	180	438	186	456	15	1/2"	1,7	9066573H	9066575H	15	1/2"	1,7	9066573H	9066575H
6 - 7	150	181	438	186	456	20	3/4"	2,8	9066574H	9066576H					
8 - 9	176	175	422	210	440	20	3/4"	2,8	9066574H	9066576H					

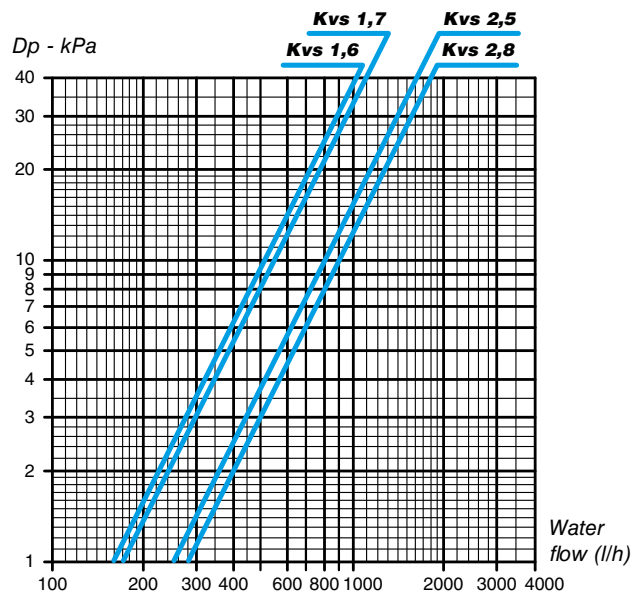

Accessories for **TEC**

3 way double valve kit for 4 tube installation and single coil

The kit consists of:

- 2 special 3 way valves;
- 2 230 Volt ON-OFF actuators with internal safety micro switch;
- insulated pipe kit;
- external valve insulation sleeve.

VERSION	TEC
MODEL	CV - CH - CVB - NC

MOD.	Ø	Kvs	FITTED		NOT FITTED	
			CODE	TYPE	CODE	TYPE
1 ÷ 9	3/4"	2,2	9066572W	V3M4X2	9066562W	V3S4X2

The kit uses a special 3 way valve which allows the transformation of the fan coil, equipped with one single coil, into a 4 tube installation.

The new **4X2** valve has been designed to keep the water flow between flow and return perfectly separated, allowing its use in parallel.

Therefore, it can be used on 4 pipe fan coil systems with one single heat-exchange coil on board the fan coil.

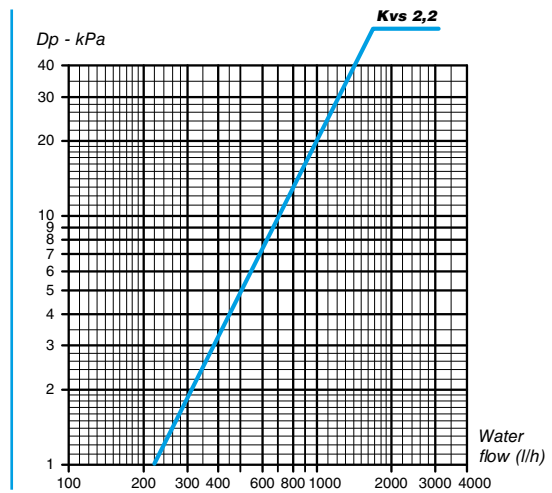
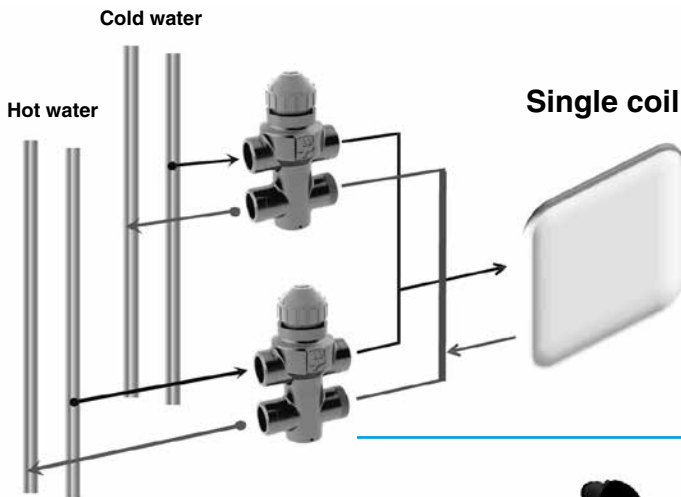

Double actuator electrical connections

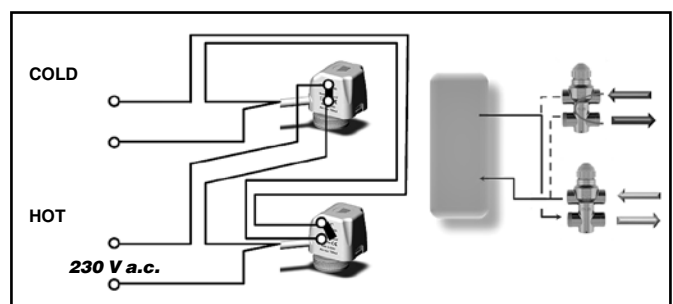
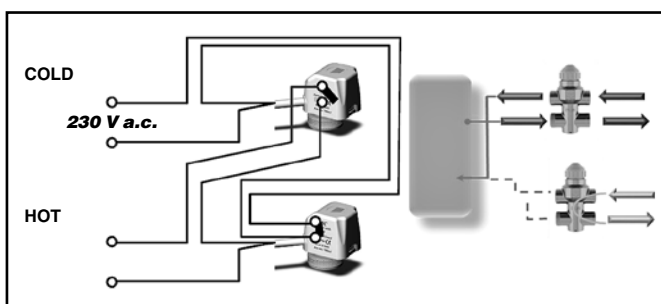

Balancing valves independent from the system pressure

- The balancing valve and a combined 2 way valve allow the regulation of the water flow value autonomously, regardless of the system pressure, and the control of the flow by using an ON/OFF electro-thermal actuator.
- The balancing valve allows you to balance the hydraulic system by supplying the required water flow, for each fan- coil, and to maintain it even under partial load conditions.
- A graduated ring nut placed under the valve allows you to set the flow rate value and also allows direct reading of the set value.



Valve operation logic

- “p1” is the valve inlet pressure.
- “p3” is the outlet pressure.
- “p2” is the diaphragm activation pressure, which allows differential pressure “p2” – “p3” to be maintained at a constant value, in order to guarantee the water to flow at the set value.

The minimum differential pressure “p1” – “p3”, required to guarantee the correct value of the set water flow rate, is indicated in the diagrams on page 30. This is an essential factor to size the system pressure drop and pump pressure head. The flow rate is kept at a constant value only if the valve pressure drop is higher than the indicated value.

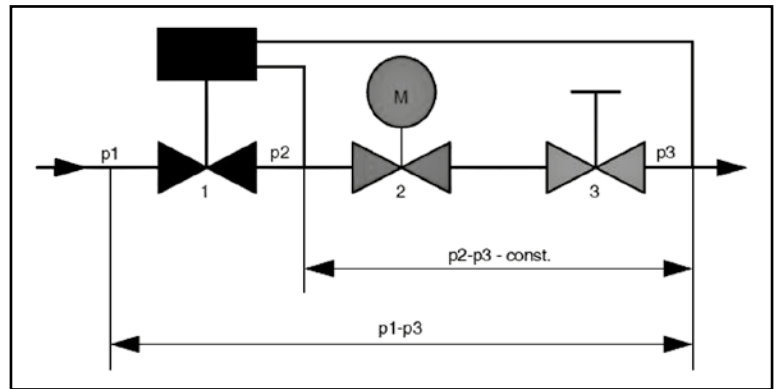

Minimum operating differential pressure

The minimum differential pressure and the balancing valve pressure drop must be considered to size the system pumps.

Flow rate is constant if the pressure drop is higher than that indicated in the diagrams on page 30.

The following diagram shows an example of the flow rate trend according to the pressure drop and calibration required.

Example DN 10 Model

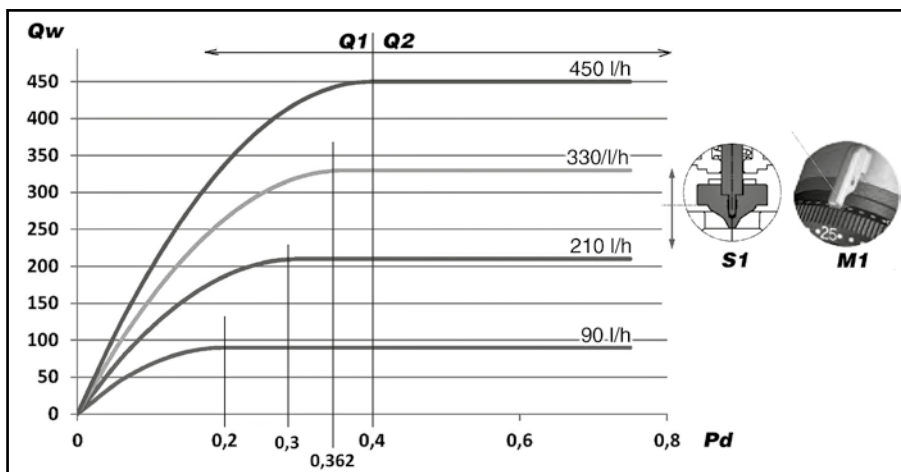

LEGEND:

- Qw** = Water flow rate
- Pd** = Min. differential pressure “p1” – “p3” (bar)
- Q1** = Area with inconstant water flow
- Q2** = Area with constant water flow
- S1** = Position of the adjustment valve plunger
- M1** = Position of the knob

Accessories for **TEC**

The valve upstream-downstream minimum differential pressure (“p1” – “p3”), which depends on the valve calibration value, must be exceeded to access the constant flow rate field.

DN 10 Model

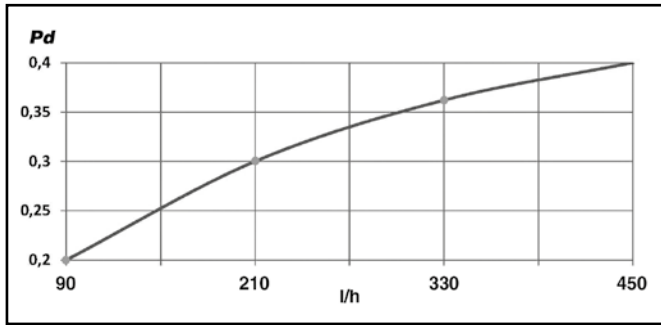

DN 15 Model

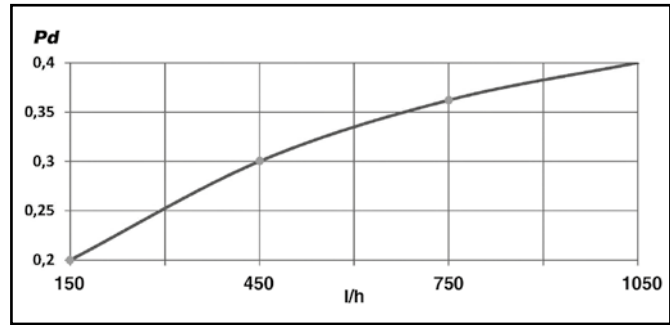

DN 20 Model

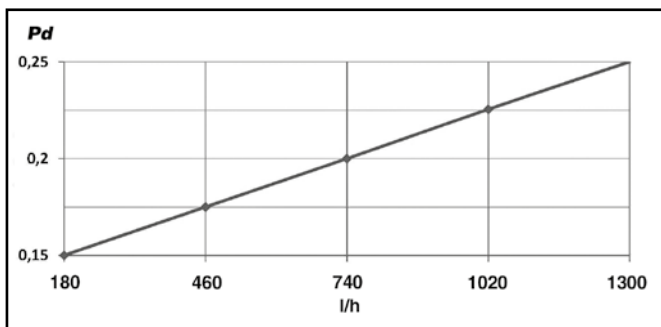

LEGEND:

Pd = Min. differential pressure “p1” – ”p3” (bar)

E.g., when sizing the system pump, in which the **DN 10** valves will be installed and in which 210 l/h are constantly required for each device, consider a useful pressure of 0.3 bar (to compensate the pressure drop of the valve) for each balancing valve. Therefore, the pressure drop values produced by the system balancing valves must be summed and the pump must be sized to produce a pressure equal to or greater than the value obtained previously.

Benefits

- Reduced dimensions.
- Easy installation on 2 or 4 pipe devices.
- Pre-regulation of the nominal value set even with installed actuator.
- Easy display of the nominal value set. Nominal values are indicated in 10 l/h without any conversion.
- Guarantee of constant flow rate set even with partial loads.
- Pre-regulation can be blocked and leaded with the locking ring.

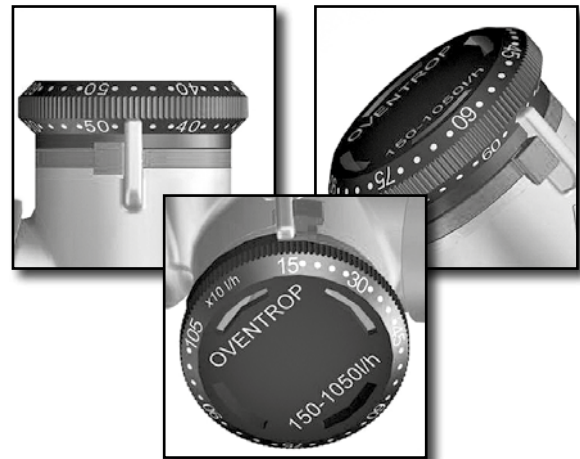

Technical features

DN MODEL	FLOW RATE RANGE (l/h)	Kvs
DN 10	90 – 450	1,1
DN 15	150 – 1050	1,8
DN 20	180 – 1300	2,5

Operation limits of the balancing valves

- Maximum operating temperature 120°C
- Maximum operating pressure 16 bar
- Maximum % of water/glycol mixture 50%
- Minimum operating temperature -10°C
- Maximum differential pressure 4 bar

Accessories for **TEC**

Balancing valves for main coil

2 way valve for main coil and assembly kit.
The valve is supplied equipped with
230 Volt electro-thermal actuator for the ON/OFF control.

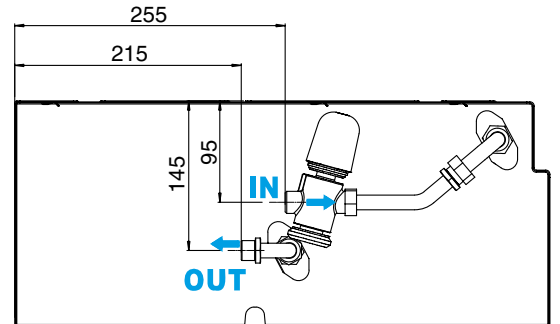
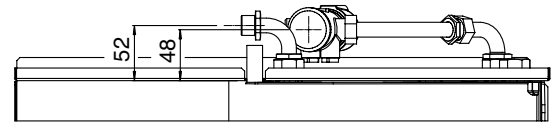

VERSION	TEC
MODEL	CV - CH - CVB - NC

MOD.	VALVE			FITTED		NOT FITTED	
	DN	Ø	Range	CODE	TYPE	CODE	TYPE
1 ÷ 3	10	1/2"	90 – 450	9066660	V2OVBPM 90-450	9066650	V2OVBPS 90-450
4 ÷ 7	15	3/4"	150 – 1050	9066661	V2OVBPM 150-1050	9066651	V2OVBPS 150-1050
8 – 9	20	1"	180 – 1300	9066662	V2OVBPM 180-1300	9066652	V2OVBPS 180-1300

Balancing valves for additional coil

2 way valve for additional coil and assembly kit.
The valve is supplied equipped with
230 Volt electro-thermal actuator for the ON/OFF control.

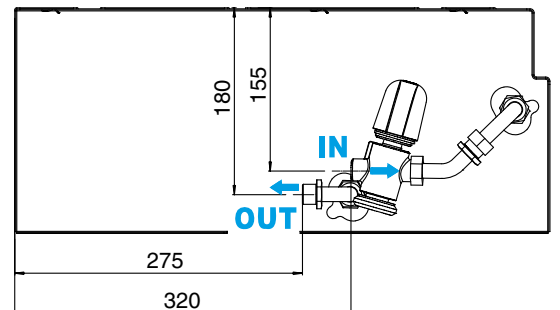
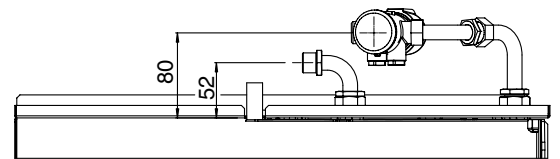

VERSION	TEC
MODEL	CV - CH - CVB - NC

MOD.	VALVE			FITTED		NOT FITTED	
	DN	Ø	Range	CODE	TYPE	CODE	TYPE
1 ÷ 5	10	1/2"	90 – 450	9066663	V2OVBAM 90-450	9066653	V2OVBAS 90-450
6 ÷ 9	15	3/4"	150 – 1050	9066664	V2OVBAM 150-1050	9066654	V2OVBAS 150-1050

2 pipe units

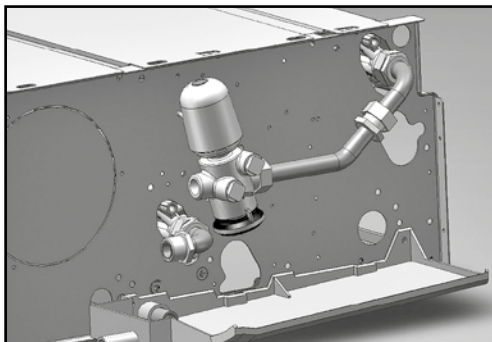

4 pipe units

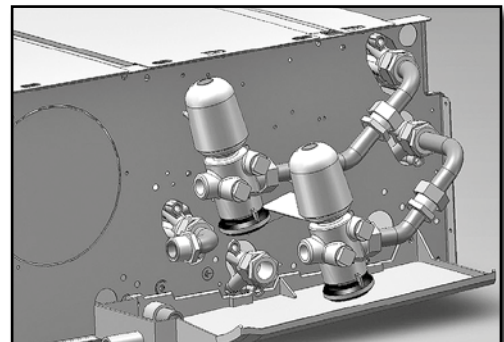

BREEZE frame kit for wall concealed installation

The Breeze frame kit is available in 3 sizes and allows the installation of recessed TEC fan coils. The kit includes a top closing panel that prevents the access to technical spaces and coil ensuring the safety of the end user.



Recessed box kit



Aesthetic frame kit



The **Aesthetic frame kit** and the **Recessed box kit** have different codes as they are separately delivered with their own packaging and they must be assembled together.

These items are only suitable for TEC models, NC version, 2-6 sizes.

When the Fan Coil is equipped with the Recessed box kit, it must be connected to a remote control and it is not possible to use the built-in electronic controls.

With the Breeze frame kit the simplified valve kits can not be installed.

Technical characteristics of the main components:

The aesthetic frame includes:

- the closing frame;
- air supply louver;
- front panel;
- air intake grid.

Perimeter frame, front panel and intake grid are made of steel painted with epoxy polyester coat, dried in a furnace at 180°, colour RAL 9003. It is possible to repaint the entire frame of the same color as the wall.



The air supply louver is made of extruded aluminum with satin finish.



The Grid is fixed to the frame by using a simple and fast connecting system and it can be easily removed to clean the filter and the inner casing.



The recessed box is made of galvanized steel with opening for the electrical and hydraulic connections. To fit in the Fan Coil easily, there are 4 grub screws.



Accessories for **TEC**

Aesthetic frame dimensions

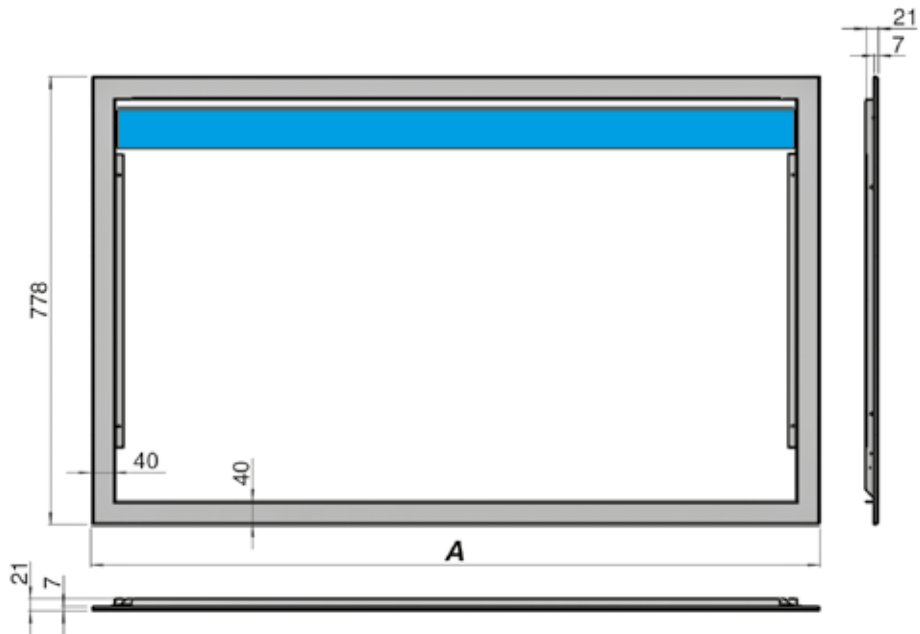

VERSION	TEC
MODEL	NC

SIZE	TYPE	A	CODE
2	CBR 2	837	9076452
3 - 4	CBR 3-4	1052	9076453
5 - 6	CBR 5-6	1267	9076455

PACKAGED AESTHETIC FRAME WEIGHT
10,5
12,5
14,5



Accessories for **TEC**

Recessed box dimensions

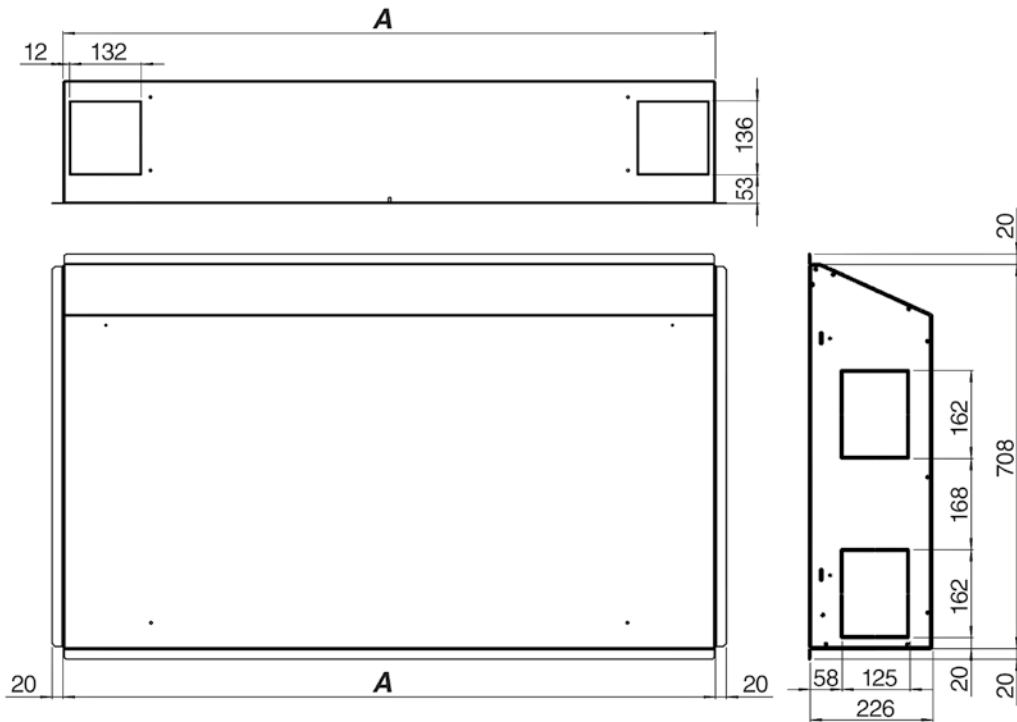

VERSION	TEC
MODEL	NC

SIZE	TYPE	A	CODE
2	IBR 2	771	9076462
3 - 4	IBR 3-4	986	9076463
5 - 6	IBR 5-6	1201	9076465

PACKAGED RECESSED BOX WEIGHT
13
16
18



Accessories for **TEC**

BEL electric heater

1 PHASE 230V Electric heater with integral: safety thermostat and relay control.

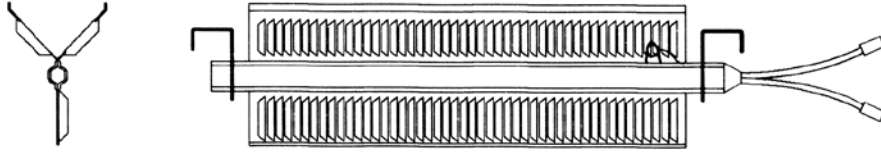

VERSION	TEC
MODEL	CV - CH - CVB - NC

CV - CH - CVB MODEL		
SIZE	WATT	CODE
1	650	9066491E
2	1000	9066492E
	600	9066482E
	400	9066472E
3 - 4	1500	9066493E
	900	9066483E
	600	9066473E
5 - 6	2000	9066495E
	1250	9066485E
	750	9066475E
7 - 8 - 9	2500	9066497E
	1500	9066487E
	1000	9066477E

NC MODEL		
SIZE	WATT	CODE
1	650	9066611
2	1000	9066612
	600	9066602
	400	9066592
3 - 4	1500	9066613
	900	9066603
	600	9066593
5 - 6	2000	9066615
	1250	9066605
	750	9066595
7 - 8 - 9	2500	9066617
	1500	9066607
	1000	9066597

BSV extension condensate collection tray to cover valve assembly (for vertical units)

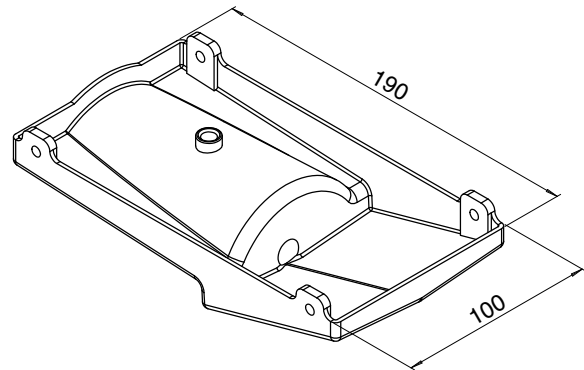

VERSION	TEC
MODEL	CV - CVB - NC (vertical)
CODE	6060400

BSO extension condensate collection tray to cover valve assembly (for CH horizontal units with casing)

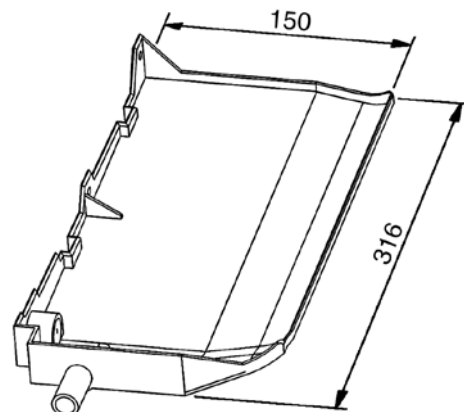

VERSION	TEC	
MODEL	CH (horizontal)	
CONNECTION SIDE	LEFT	RIGHT
TYPE	BSO-SX	BSO-DX
CODE	6060402	6060403

Accessories for **TEC**

BSI-C extension condensate collection tray to cover valve assembly (for NC horizontal units without casing)

Not to be used with **KAF** accessory.

VERSION	TEC
MODEL	NC (horizontal)
CODE	6066039

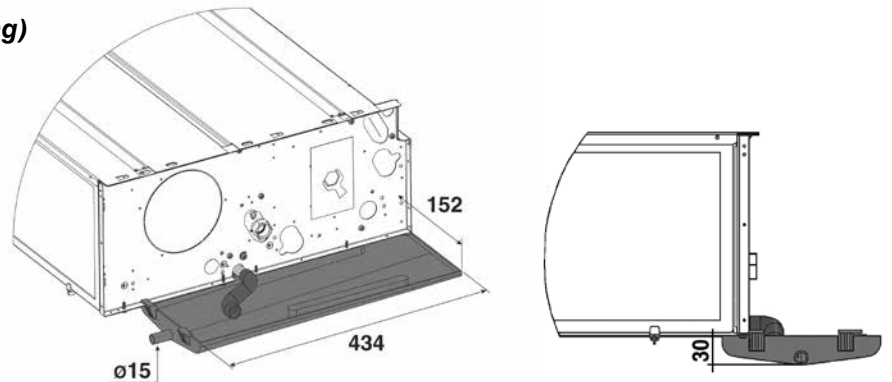

DRPV-C fitted condensate pump (for vertical units)

	FITTED	NOT FITTED
TYPE	DRPV-C-M	DRPV-C-S
CODE	9066297	9066296

HEIGHT FOR VERTICAL FLOW (m)	WATER FLOW (l/h) DEPENDENT ON THE LENGTH OF HORIZONTAL FLOW	
	5 m	10 m
1	7,6	7,2
2	5,6	5,2
3	4,0	3,7
4	3,2	2,9



VERSION	TEC
MODEL	CV - CVB - NC (vertical)

DRPO-C fitted condensate pump (for CH horizontal units, fitted on the unit)

VERSION	TEC
MODEL	CH (horizontal)
CODE	9066295

HEIGHT FOR VERTICAL FLOW (m)	WATER FLOW (l/h) DEPENDENT ON THE LENGTH OF HORIZONTAL FLOW	
	5 m	10 m
1	7,6	7,2
2	5,6	5,2
3	4,0	3,7
4	3,2	2,9

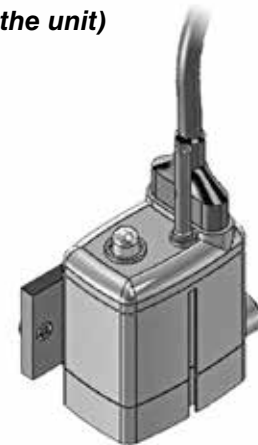

DRPI-C not fitted condensate pump (for NC horizontal units)

VERSION	TEC
MODEL	NC (horizontal)
CODE	9066180

HEIGHT FOR VERTICAL FLOW (m)	WATER FLOW (l/h) DEPENDENT ON THE LENGTH OF HORIZONTAL FLOW	
	5 m	10 m
1	7,6	7,2
2	5,6	5,2
3	4,0	3,7
4	3,2	2,9



Accessories for **TEC**

SCR plastic condensate drain pipe with fast connection

(allows correct condensate drain)

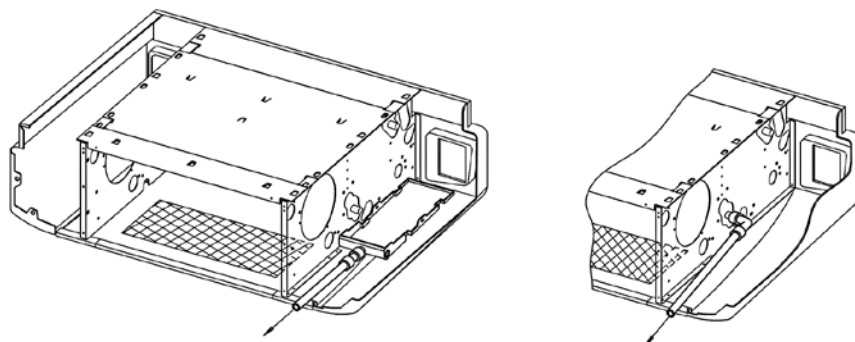

VERSION	TEC
MODEL	CH - NC
CODE	6060420

PAP feet

VERSION	TEC
MODEL	CV

SIZE	L	CODE
1	330	9060150
2	430	9060150
3 - 4	645	9060150
5 - 6	860	9060150
7	1119	9060150
8 - 9	1119	9060151

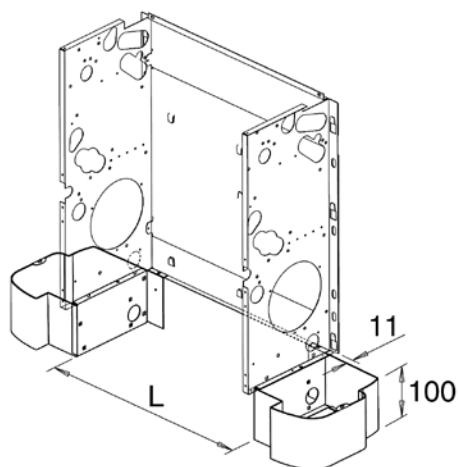

GAP

Aluminium low intake grid
(to be installed with PAP feet)

VERSION	TEC
MODEL	CV

SIZE	CODE
1	9066541
2	9066542
3 - 4	9066543
5 - 6	9066545
7 ÷ 9	9066547

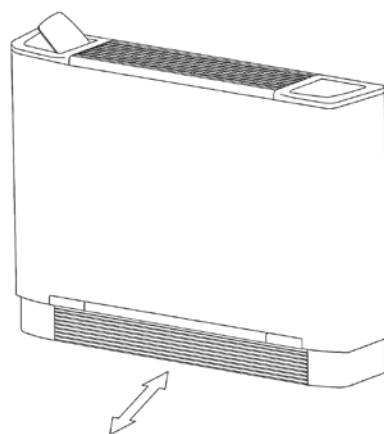

KAF frontal intake kit

Bottom closing panel and filter sliding guides.

VERSION	TEC
MODEL	NC

SIZE	CODE
1	9066501
2	9066502
3 - 4	9066503
5 - 6	9066505
7	9066507
8 - 9	9066508

Not to be used
with **BSI-C** accessory.

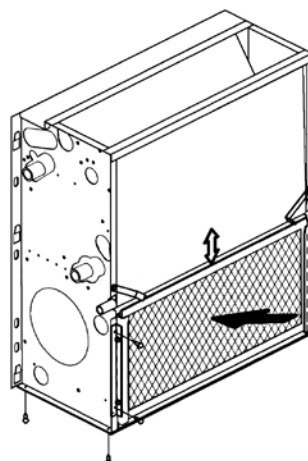

Accessories for **TEC**

PCVL rear closing panel (for vertical units)

SIZE	CODE
1	9070139
2	9070140
3 - 4	9070141
5 - 6	9070142
7 ÷ 9	9070143

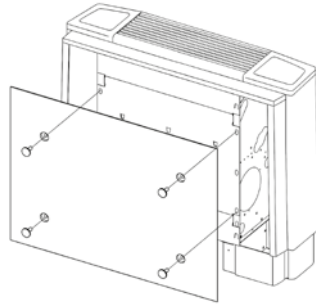

VERSION	TEC
MODEL	CV - CVB

PCOL bottom closing panel (for horizontal units)

SIZE	CODE
1	9070219
2	9070220
3 - 4	9070221
5 - 6	9070222
7	9070223
8 - 9	9070224

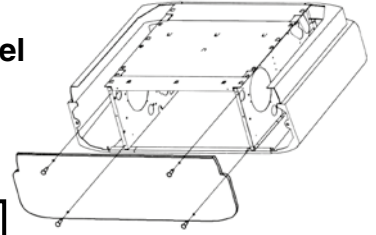

VERSION	TEC
MODEL	CH

SAEM fresh air mixing damper (factory mounted with feet and intake grid included, CV only)

VERSION	TEC
MODEL	CV

(can be motorized on request)

SIZE	A	B	L	CODE
1	186	78	354	9076331
2	186	78	454	9076332
3 - 4	186	78	669	9076333
5 - 6	186	78	884	9076335
7	186	78	1099	9076337
8 - 9	216	108	1099	9076338

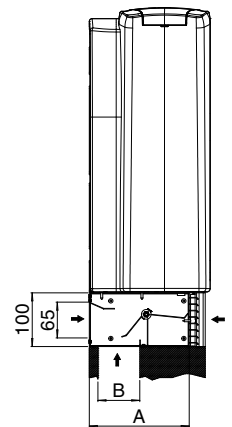
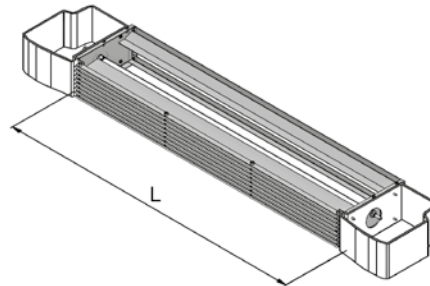

SAE fresh air mixing damper (not mounted, NC only)

VERSION	TEC
MODEL	NC

(can be motorized on request)

SIZE	A	B	L	CODE
1	186	78	354	9066531
2	186	78	454	9066532
3 - 4	186	78	669	9066533
5 - 6	186	78	884	9066535
7	186	78	1099	9066537
8 - 9	216	108	1099	9066538

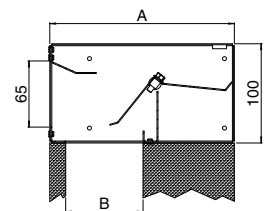
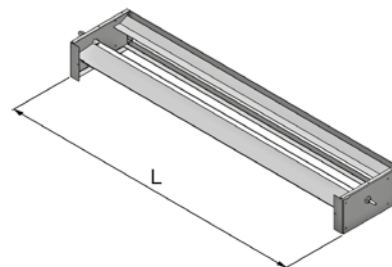

Belimo motor

Fitted on the unit for motorized version of the SAE damper (available with "IAQ" control only).

VERSION	TEC
MODEL	CV - NC
TYPE	BESAE
CODE	9066620

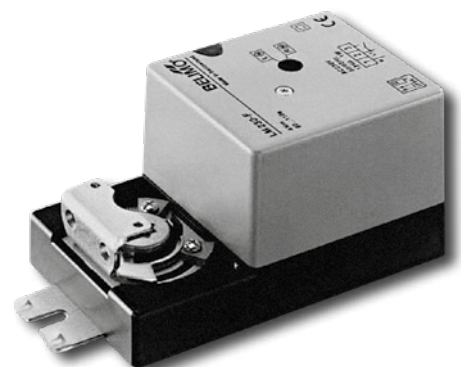

Accessories for **TEC**

FRD straight inlet flange

Can be used together with GRAG air inlet grid.
Made of galvanized steel.

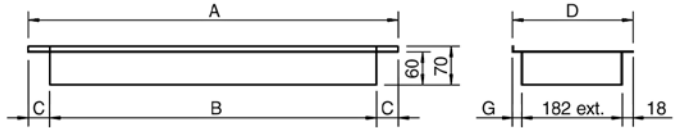

SIZE	TYPE	A	B	C	D	G	CODE
1	FRD - 1	354	290	32	216	16	9066451
2	FRD - 2	454	390	32	216	16	9060720
3 - 4	FRD - 3/4	669	590	39,5	216	16	9060721
5 - 6	FRD - 5/6	884	790	47	216	16	9060722
7	FRD - 7	1099	990	54,5	216	16	9060723
8 - 9	FRD - 8/9	1099	990	54,5	246	46	9060724

VERSION	TEC
MODEL	NC

FR 90 90° inlet flange

Can be used together with GRAP air inlet grid.
Made of galvanized steel.

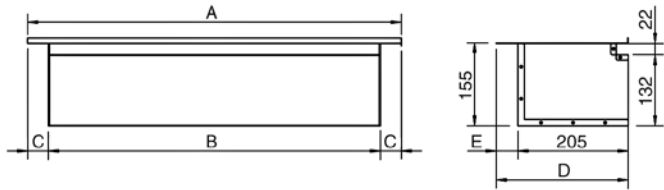

SIZE	TYPE	A	B	C	D	E	CODE
1	FR90 - 1	354	290	32	216	11	9066441
2	FR90 - 2	454	390	32	216	11	9060710
3 - 4	FR90 - 3/4	669	590	39,5	216	11	9060711
5 - 6	FR90 - 5/6	884	790	47	216	11	9060712
7	FR90 - 7	1099	990	54,5	216	11	9060713
8 - 9	FR90 - 8/9	1099	990	54,5	246	41	9060714

VERSION	TEC
MODEL	NC

GRAP air inlet grid

To be used with FR 90 90° inlet flange.
Made of anodized aluminium.

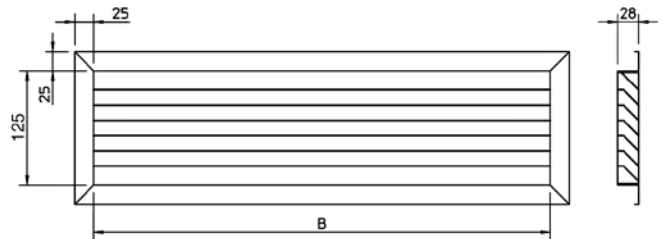

SIZE	TYPE	DESCRIPTION	B	CODE
1	GRAP - 1	Grid 300x150	275	9066421
2	GRAP - 2	Grid 400x150	375	9060760
3 - 4	GRAP - 3/4	Grid 600x150	575	9060761
5 - 6	GRAP - 5/6	Grid 800x150	775	9060762
7 ÷ 9	GRAP - 7/9	Grid 1000x150	975	9060763

VERSION	TEC
MODEL	NC

GRAG air inlet grid

To be used with FRD straight inlet flange.
Made of anodized aluminium.

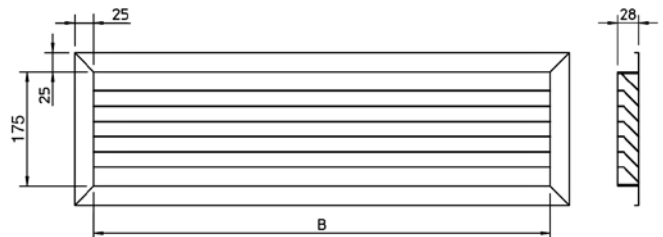

SIZE	TYPE	DESCRIPTION	B	CODE
1	GRAG - 1	Grid 300x200	275	9066431
2	GRAG - 2	Grid 400x200	375	9060764
3 - 4	GRAG - 3/4	Grid 600x200	575	9060765
5 - 6	GRAG - 5/6	Grid 800x200	775	9060766
7 ÷ 9	GRAG - 7/9	Grid 1000x200	975	9060767

VERSION	TEC
MODEL	NC

Accessories for **TEC**

FRC fresh air connection (not mounted)

VERSION	TEC
MODEL	NC

SIZE	TYPE	A	CODE
1 ÷ 7	FRC 100	98	6064191
1 ÷ 7	FRC 120	122	6064192

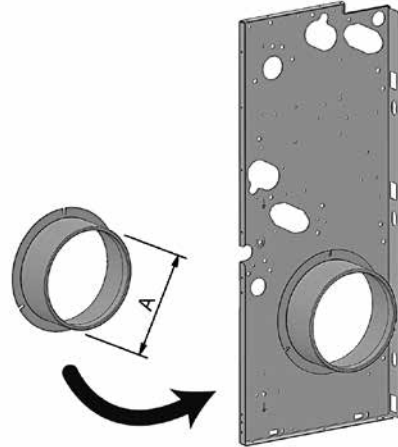

FMD straight outlet flange

Made of galvanized steel.

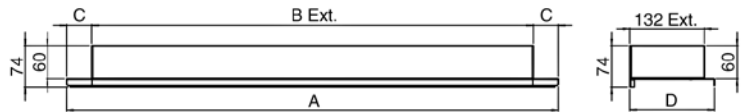

SIZE	TYPE	A	B	C	D	CODE
1	FMD - 1	352	290	31	152	9066371
2	FMD - 2	452	390	31	152	9066372
3 - 4	FMD - 3/4	667	590	38,5	152	9066373
5 - 6	FMD - 5/6	882	790	46	152	9066375
7	FMD - 7	1097	990	53,5	152	9066377
8 - 9	FMD - 8/9	1097	990	53,5	179	9066378

VERSION	TEC
MODEL	NC

FM 90 90° outlet flange

Made of galvanized steel
insulated with polyethylene lining.

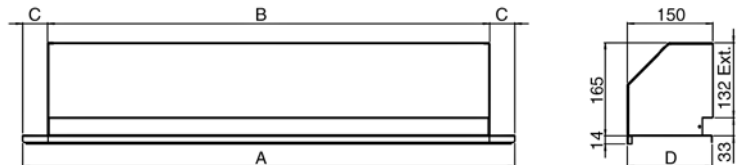

SIZE	TYPE	A	B	C	D	CODE
1	FM90 - 1	352	290	31	152	9066381
2	FM90 - 2	452	390	31	152	9066382
3 - 4	FM90 - 3/4	667	590	38,5	152	9066383
5 - 6	FM90 - 5/6	882	790	46	152	9066385
7	FM90 - 7	1097	990	53,5	152	9066387
8 - 9	FM90 - 8/9	1097	990	53,5	179	9066388

VERSION	TEC
MODEL	NC

BMA air outlet grid

Double louvre grid to be fitted to the duct,
to the FMD straight outlet flange
or to the FM 90 90° outlet flange.
Made of anodized aluminium.

SIZE	TYPE	B	CODE
1	BMA - 1	275	9066411
2	BMA - 2	375	9060750
3 - 4	BMA - 3/4	575	9060751
5 - 6	BMA - 5/6	775	9060752
7 ÷ 9	BMA - 7/9	975	9060753

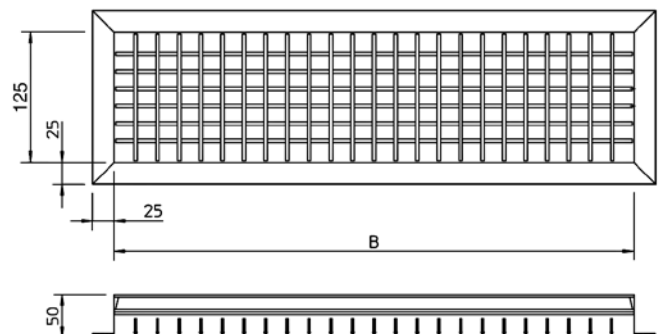

VERSION	TEC
MODEL	NC

Accessories for **TEC**

PRC air inlet spigot plenum

Made of galvanized steel insulated with polyethylene lining.

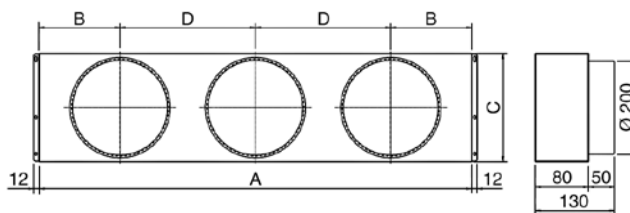

SIZE	TYPE	A	B	C	D	SPIGOTS	CODE
1	PRC - 1	330	165	218	/	N° 1	9066461
2	PRC - 2	430	107	218	216	N° 2	9066462
3 - 4	PRC - 3/4	645	166	218	313	N° 2	9066463
5 - 6	PRC - 5/6	860	160	218	270	N° 3	9066465
7	PRC - 7	1075	190	218	347,5	N° 3	9066467
8 - 9	PRC - 8/9	1075	190	248	347,5	N° 3	9066468

All the plenums are supplied with spigots for the connection of flexible ducts.

VERSION	TEC
MODEL	NC

PMC spigot diffuser

Made of galvanized steel insulated with polyethylene lining.

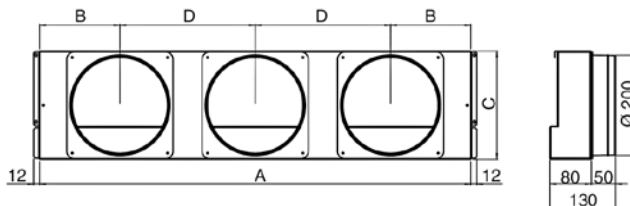

SIZE	TYPE	A	B	C	D	SPIGOTS	CODE
1	PMC - 1	330	165	218	/	N° 1	9066361
2	PMC - 2	430	107	218	216	N° 2	9066362
3 - 4	PMC - 3/4	645	166	218	313	N° 2	9066363
5 - 6	PMC - 5/6	860	160	218	270	N° 3	9066365
7	PMC - 7	1075	190	218	347,5	N° 3	9066367
8 - 9	PMC - 8/9	1075	190	248	347,5	N° 3	9066368

All the plenums are supplied with spigots for the connection of flexible ducts.

VERSION	TEC
MODEL	NC

GRAFP air inlet grid with filter

To be fitted to the FR 90 90° inlet flange. Made of anodized aluminium.

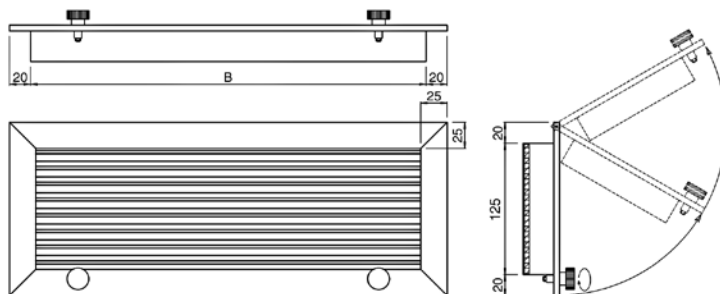

SIZE	TYPE	B	CODE
1	GRAFP - 1	275	9066391
2	GRAFP - 2	375	9060770
3 - 4	GRAFP - 3/4	575	9060771
5 - 6	GRAFP - 5/6	775	9060772
7 ÷ 9	GRAFP - 7/9	975	9060773

VERSION	TEC
MODEL	NC

GRAFG air inlet grid with filter

To be fitted to the FRD straight inlet flange. Made of anodized aluminium.

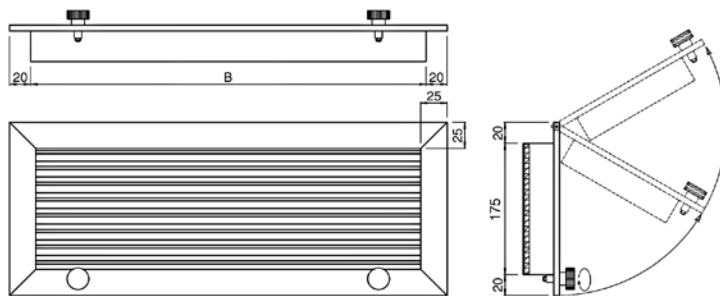

SIZE	TYPE	B	CODE
1	GRAFG - 1	275	9066401
2	GRAFG - 2	375	9060774
3 - 4	GRAFG - 3/4	575	9060775
5 - 6	GRAFG - 5/6	775	9060776
7 ÷ 9	GRAFG - 7/9	975	9060777

VERSION	TEC
MODEL	NC

Accessories for **TEC**

CHK Hotel fan kit

Hotel box for concealed installation for NC Horizontal Installation (frontal return and supply).

The new CHK kit is the best solution for all installations requiring a built-in fan coil where there is no other possibility of accessing the unit except from the air outlet side. The unit is particularly suitable for installation in hotel rooms, offices and homes.

The Kit consists of a box that can easily be installed in a false ceiling, inside which the fan coil is fitted using the special guides. For simply remove the front outlet and access the air filter as well as the electrical and hydraulic parts of the unit.

The air grid is divided into two zones, one for the air intake with horizontally adjustable fins and the other one for the air outlet with horizontally and vertically adjustable fins to ensure better air distribution and diffusion in the room.

The box structure is made of thick galvanised metal sheet.

The internal air flow sections are insulated with expanded polyethylene that prevents both condensation and energy loss towards the inside of the false ceiling.

The accessory includes the air filter, an anodised aluminium outlet with adjustable fins and a front wall frame.

The box structure is designed so that fan coils with hydraulic connections facing left or right can be installed. According to the configuration, it is in fact sufficient to secure the sliding guides on the panel that will be the upper one.



When ordering, it must be specified that the fan coil hydraulic and electrical connections must be on the same side.

Note: consider 20 Pa pressure drop.

VERSION	TEC		
MODEL	NC (HORIZONTAL)		

SIZE	TYPE	A	CODE
3 - 4	CHK 3-4	1060	9066783
5 - 6	CHK 5-6	1316	9066785
7	CHK 7	1610	9066787

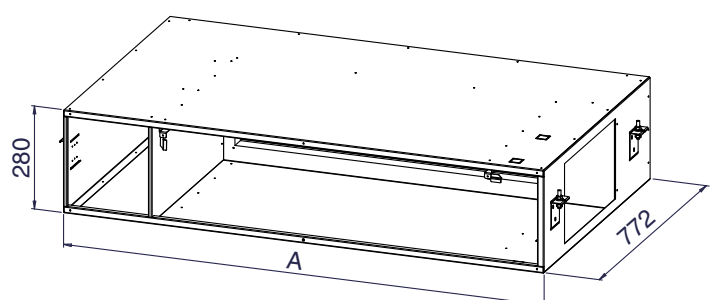

BXS silencers plenum

Sound attenuator module

Made of galvanised steel metal sheet, lined internally with a reinforced glass wool mat on both sides with a black glass coating; the 50 mm and 30 kg/m³ density lining ensures high noise reduction with very low pressure drops.

Sound attenuation levels

FREQUENCY	Hz	125	250	500	1000	2000	4000	8000
SOUND ATTENUATION	dB	2.5	5.0	11.5	14.0	13.5	12.0	11.0

Note: the silencer plenum reduces the sound levels only on the supply side; the sound levels on the return side are not affected by the silencer.

VERSION	TEC
MODEL	NC

SIZE	TYPE	L	L1	A	CODE
3 - 4	BXS-A	675	597	653	9069081
5 - 6	BXS-B	890	812	868	9069082
7 ÷ 9	BXS-C	1105	1027	1083	9069083

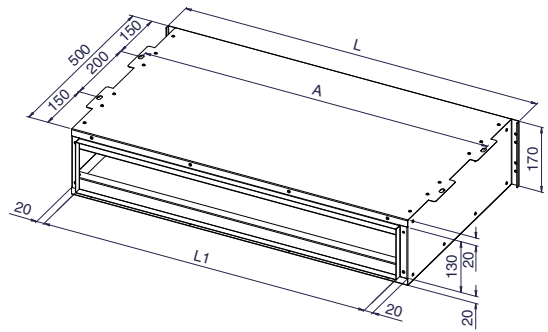

Silencer plenum pressure drop

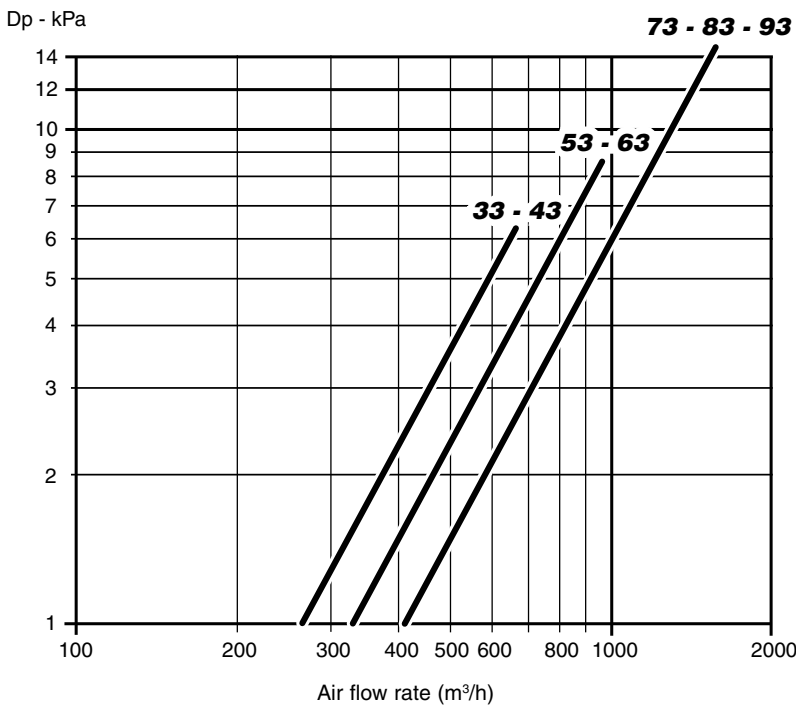

Electronic controls to be fitted on CV-CVB units

IDENTIFICATION	CODE
MV-3V	9060130

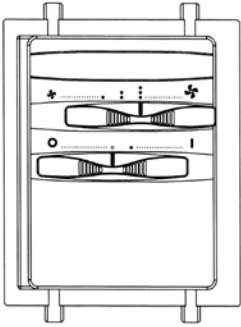

- ON-OFF switch and 3 speed switch.
- Without thermostatic control.
- It allows to control the low temperature cut-out thermostat (TMM).

IDENTIFICATION	CODE
TMV-S	9060140

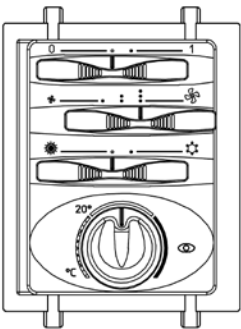

- ON-OFF switch.
- 3 speed switch.
- Summer/Winter switch.
- Electronic room thermostat for fan or valve control (ON-OFF).
- It allows to control the low temperature cut-out thermostat (TMM).
- It allows to control the chilled water valve (ON-OFF) and the electric heater (BEL) only in case that hot water is not used in winter (otherwise please use TMV-R-IAQ control with on/off switch for the electric heater).

IDENTIFICATION	CODE
TMV-C	9060133

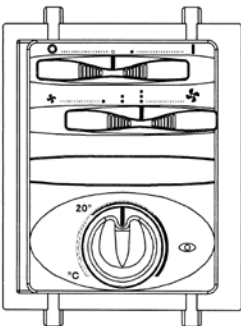

- ON-OFF switch.
- 3 speed switch.
- It allows to control the summer or winter cycle with centralized and remote switch, or an automatic change-over fitted on the water pipe (for 2-tube installations only).
- Electronic room thermostat for fan or valve control (ON-OFF).
- It allows to control the low temperature cut-out thermostat (TME).
- It allows to control the chilled water valve (ON-OFF) and the electric heater (BEL) only in case that hot water is not used in winter (otherwise please use TMV-T-IAQ control with on/off switch for the electric heater).

IDENTIFICATION	CODE
TMV-AUT	9066319

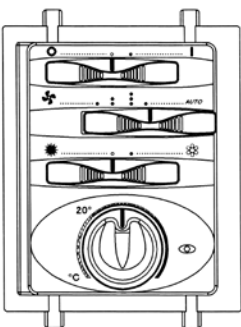

- Manual or automatic speed switch: on Auto Mode there is the automatic speed selection in accordance to the difference between room temperature and setpoint. When the setpoint is reached the fan go on OFF.
- Summer/Winter switch.
- Electronic room thermostat for valve(s) control (ON-OFF).
- Simultaneous thermostatic control of the valves and fan.
- It allows to control the low temperature cut-out (NTC).
- It allows to control the chilled water valve (ON-OFF) and the electric heater (BEL) only in case that hot water is not used in winter (otherwise please use TMV-AU-IAQ control with on/off switch for the electric heater).
- It allows to control the summer/winter cycle with a centralized and remote switch or with an automatic change-over fitted on the water pipe (for 2-tube installations only).

N.B.: with 4 pipe installations and continuous chilled and hot water supply, it allows the automatic summer/winter change-over in accordance to the room temperature (-1°C = Winter, +1°C = Summer, Neutral Zone 2°C).

Wall electronic controls

IDENTIFICATION	CODE
WM-3V	9066642



Dimensions: 75x75x30 mm

- Manual 3 speed switch.
- Without thermostatic control.
- It does not control the valves.

IDENTIFICATION	CODE
WM-T	9066630E



Dimensions: 135x86x31 mm

- ON-OFF switch.
- Manual 3 speed switch.
- Manual Summer/Winter switch.
- Electronic room thermostat for fan control (ON-OFF).
- Electronic room thermostat for valve control (ON-OFF) (the fan keeps working).
- It allows to control the low temperature cut-out thermostat (TMM).
- It allows to control the chilled water valve (ON-OFF) and the electric heater (BEL) only in case that hot water is not used in winter (otherwise please use WM-TQR control with on/off switch for the electric heater).
- Presence of a LED signal when the thermostat is on.

Control power absorption: 0,25 VA

IDENTIFICATION	CODE
WM-TQR	9066631E



Dimensions: 135x86x31 mm

- ON-OFF switch.
- Manual 3 speed switch.
- Manual, automatic or centralized Summer/Winter switch.
- Electric heater activation button.
- Electronic room thermostat for fan control (ON-OFF).
- Electronic room thermostat for valve control (ON-OFF).
- Simultaneous thermostatic control of the valves and fan.
- It allows to control the low temperature cut-out thermostat (NTC).
- It allows to control the water valves (ON-OFF) and the electric heater managed as main heating element or as an integration element.
- Energy saving function.
- Presence of a LED signal when the thermostat is on.

Control power absorption: 1 VA

IDENTIFICATION	CODE
WM-AU	9066632E

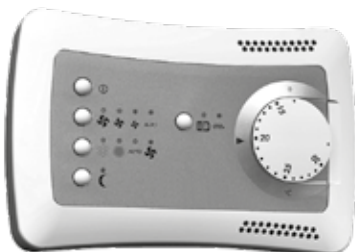

Dimensions: 135x86x24 mm

The control must always be connected with UPM-AU power unit (fitted on the unit) or with UP-AU power unit (not fitted on the unit).

- ON-OFF push button.
- Manual, automatic or centralized Summer/Winter switch.
- Manual or automatic 3 speed progressive push button.
- Summer/Winter/Fan/Auto mode push button.
- Electric heater activation button.
- Electronic room thermostat for fan control (ON-OFF).
- Electronic room thermostat for valve control (ON-OFF).
- Simultaneous thermostatic control of the valves and fan.
- It allows to control the low temperature cut-out thermostat (NTC).
- It allows to control the water valves (ON-OFF) and the electric heater managed as main heating element or as an integration element.
- Energy saving push button.
- Presence of a LED signal when the thermostat is on.

N.B.: with 4 pipe installations and continuous chilled and hot water supply, it allows the automatic summer winter change-over in accordance to the room temperature (-1°C = Winter, +1°C = Summer, Neutral Zone 2°C).

Control power absorption: see the UP-AU power unit

Wall electronic controls

IDENTIFICATION

CODE

T-MB

9066331E

The control must always be connected with UPM-AU power unit (fitted on the unit) or with UP-AU power unit (not fitted on the unit).

Wall control with display that allows controlling one or more units in Master/Slave mode. The control is equipped with internal sensor to detect the room temperature, which can be defined as a priority compared to the return air sensor on the fan coil.



Dimensions: 110x72x25 mm

The T-MB control features the following functions:

- Switch the unit ON and OFF.
- Temperature set.
- Manual, centralized or automatic Summer/Winter switch.
- Set the fan speed (low, medium, high or autofan).
- Set the operation mode (fan only, cooling, heating; auto for 4 pipe systems with mode selection depending on the air temperature).
- Possibility of use of the low temperature cut-out thermostat NTC mounted on the UP-AU power unit.
- It allows to control the water valves (ON-OFF) and the electric heater managed as main heating element or as an integration element.
- Time setting and Weekly ON/OFF program.

Control power absorption: see the UP-AU power unit

IDENTIFICATION

CODE

WM-503

9066676E

The WM-503 control is designed to be installed in a 503 wall box.

Easy to use, it is equipped with a large and efficient backlit LCD screen with 4 keys.

The thermostat is delivered with an external frame conceived for several combinations with adaptors and covers that make it suitable for more than 25 different frames belonging to various brands.



Dimensions: 68x52.2x58 mm

- Manual or automatic 3 speed switch.
- One single digital input to select: ON-OFF/SETPOINT reduction/Summer-Winter switch.
- Electronic room thermostat for fan control (ON-OFF).
- Electronic room thermostat for 1 water valve control (ON-OFF) (2 pipe system).
- Electronic room thermostat for 2 water valves control (ON-OFF) (4 pipe system).
- Simultaneous thermostatic control of the valves and fan.
- One single input to select: return air/water/change-over control probe.
- Possibility to use a low temperature cut-out thermostat NTC (optional).

Control power absorption: see the UP-503 power unit

IDENTIFICATION

CODE

T2T

9060174

2 pipes units only.



Dimensions: 128x75x25 mm

- ON-OFF switch.
- 3 speed switch.
- Manual Summer/Winter switch.
- Thermostatic control on the fan.
- Thermostatic control on the valve and continuous fan operation.
- Simultaneous thermostatic control of the valve and fan.
- Cannot be used with speed switch (master-slave).

Control power absorption: 1,5 VA

Electronic controls to be fitted on **TEC units with electric heater**

IDENTIFICATION	CODE
TMV-R-IAQ	9063006

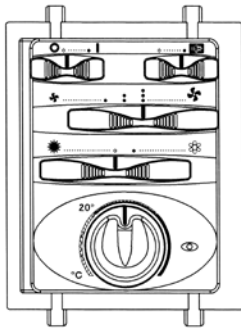

- ON-OFF switch.
- 3 speed switch.
- Summer/Winter switch.
- Electric heater ON-OFF switch.
- Electronic room thermostat for fan or valve control (ON-OFF).
- It allows to control the low temperature cut-out thermostat (TME).
- It allows to control the chilled water valve (ON-OFF) and the electric heater (BEL) only in case that hot water is not used in winter.
- It allows to control the summer/winter cycle with a centralized and remote switch or with an automatic change-over fitted on the water pipe (for 2-tube installations only).

IDENTIFICATION	CODE
TMV-AUT-IAQ	9066643

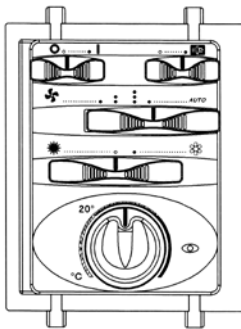

- Manual or automatic speed switch: on Auto Mode there is the automatic speed selection in accordance to the difference between room temperature and setpoint. When the setpoint is reached the fan and the filter go on OFF.
- Summer/Winter switch.
- Electric heater ON-OFF switch.
- Electronic room thermostat for valve control (ON-OFF).
- It allows to control the low temperature cut-out (TME).
- It allows to control the chilled water valve (ON-OFF) and the electric heater (BEL) only in case that hot water is not used in winter.
- It allows to control the summer/winter cycle with a centralized and remote switch or with an automatic change-over fitted on the water pipe (for 2-tube installations only).

N.B.: with 4 pipe installations and continuous chilled and hot water supply, it allows the automatic summer/winter change-over in accordance to the room temperature (-1°C = Winter, +1°C = Summer, Neutral Zone 2°C).

Wall electronic controls for **TEC units with electric heater**

IDENTIFICATION

CODE

WM-TQR

9066631E



Dimensions: 135x86x31 mm

- ON-OFF switch.
- Manual 3 speed switch.
- Manual, automatic or centralized Summer/Winter switch.
- Electric heater activation button.
- Electronic room thermostat for fan control (ON-OFF).
- Electronic room thermostat for valve control (ON-OFF).
- Simultaneous thermostatic control of the valves and fan.
- It allows to control the low temperature cut-out thermostat (NTC).
- It allows to control the water valves (ON-OFF) and the electric heater managed as main heating element or as an integration element.
- Energy saving function.
- Presence of a LED signal when the thermostat is on.

Control power absorption: 1 VA

IDENTIFICATION

CODE

WM-AU

9066632E

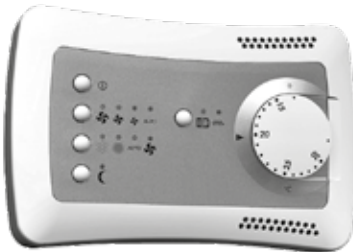

Dimensions: 135x86x24 mm

The control must always be connected with UPM-AU power unit (fitted on the unit) or with UP-AU power unit (not fitted on the unit).

- ON-OFF push button.
- Manual, automatic or centralized Summer/Winter switch.
- Manual or automatic 3 speed progressive push button.
- Summer/Winter/Fan/Auto mode push button.
- Electric heater activation button.
- Electronic room thermostat for fan control (ON-OFF).
- Electronic room thermostat for valve control (ON-OFF).
- Simultaneous thermostatic control of the valves and fan.
- It allows to control the low temperature cut-out thermostat (NTC).
- It allows to control the water valves (ON-OFF) and the electric heater managed as main heating element or as an integration element.
- Energy saving push button.
- Presence of a LED signal when the thermostat is on.

N.B.: with 4 pipe installations and continuous chilled and hot water supply, it allows the automatic summer winter change-over in accordance to the room temperature (-1°C = Winter, +1°C = Summer, Neutral Zone 2°C).

Control power absorption: see the UP-AU power unit

IDENTIFICATION

CODE

T-MB

9066331E



Dimensions: 110x72x25 mm

The control must always be connected with UPM-AU power unit (fitted on the unit) or with UP-AU power unit (not fitted on the unit).

Wall control with display that allows controlling one or more units in Master/Slave mode. The control is equipped with internal sensor to detect the room temperature, which can be defined as a priority compared to the return air sensor on the fan coil.

The T-MB control features the following functions:

- Switch the unit ON and OFF.
- Temperature set.
- Manual, centralized or automatic Summer/Winter switch.
- Set the fan speed (low, medium, high or autofan).
- Set the operation mode (fan only, cooling, heating; auto for 4 pipe systems with mode selection depending on the air temperature).
- Possibility of use of the low temperature cut-out thermostat NTC mounted on the UP-AU power unit.
- It allows to control the water valves (ON-OFF) and the electric heater managed as main heating element or as an integration element.
- Time setting and Weekly ON/OFF program.

Control power absorption: see the UP-AU power unit

Speed switches

IDENTIFICATION	CODE
SEL-V	9060136

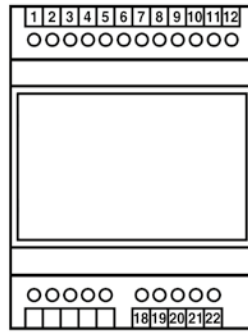
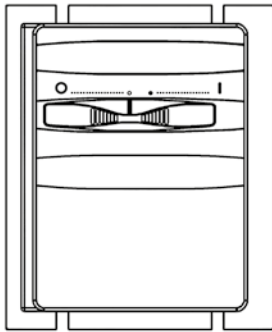

For CV-CVB models.

- Speed switch (Slave).
- It allows to control up to 8 units with only one centralized wall control (1 speed switch for each unit).
- For controls WM-T and WM-TQR.

IDENTIFICATION	CODE
SEL-CR	9066311



For CH-NC models.

- Speed switch (Slave).
- It allows to control up to 8 units with only one centralized wall control (1 speed switch for each unit).
- For controls WM-T and WM-TQR.

DESCRIPTION	IDENTIFICATION	CODE
Power unit for WM-AU and T-MB remote control (fitted on the unit)	UPM-AU	9066641
Power unit for WM-AU and T-MB remote control (not fitted on the unit)	UP-AU	9066640

Power unit to be installed on the fan coil (fan coil interface).



- It controls the fan and the valves of the fan coil.
- It is connected to the electric supply.
- It receives the information required from the control.
- Possibility to use the low temperature cut-out thermostat (optional) for the T1 function which allows the return air control.
- Possibility to use the low temperature cut-out thermostat (optional) for the T2 function which controls the summer/winter switch.
- Possibility to use the low temperature cut-out thermostat (optional) for the T3 function as low temperature cut-out thermostat.
- It allows to control up to 10 units (1 master and 9 slaves).
- Max. Network length: 100 meters.
- Max cable length between control and first connected power unit: 20 meters.

Control power absorption: 2,3 VA

IDENTIFICATION	CODE
UP-503	9066677



Power unit to be installed on the fan coil (fan coil interface).

- It controls the fan and the valves of the fan coil.
- It is connected to the electric supply.
- It receives the information required from the control WM-503.
- It allows to control up to 5 units (1 master and 4 slaves).
- Max. Network length: 100 meters.
- Max cable length between control and first connected power unit: 20 meters.

Control power absorption: 2 VA

Electronic control accessories for **TEC**

TME low temperature cut-out thermostat

To be fitted between the coil fins. When connecting the control, the TME probe cable must be separated from the power supply wires.
To be used with the following controls: TMV-C, TMV-R-IAQ and TMV-AU-IAQ.
It stops the fan when the water temperature is lower than 38°C and it starts the fan when is higher than 42°C.

VERSION	TEC
MODEL	CV - CH - CVB - NC
CODE	3021091



TMM low temperature cut-out thermostat

To be installed in contact with the hot water circuit.
To be used with the following controls: TMV-S and WM-T.
For units working on heating only.
It stops the fan when the water temperature is lower than 30°C and it starts the fan when is higher than 38°C.

VERSION	TEC
MODEL	CV - CH - CVB - NC
CODE	9053048



NTC low temperature cut-out thermostat

To be fitted between the coil fins. When connecting the control, the NTC probe cable must be separated from the power supply wires.
To be used with controls TMV-AUT, WM-TQR and UP-AU, UP-503 power units.
It stops the fan when the water temperature is lower than 28°C and it starts the fan when is higher than 33°C.

To use as:

- T1 function for the return air control.
- T2 function which controls the summer/winter switch.
- T3 function as low temperature cut-out thermostat.

VERSION	TEC
MODEL	CV - CH - CVB - NC
CODE	3021090



Change-Over CH 15-25

Automatic summer/winter switch
to be installed in contact with the water circuit.
For 2-tube installations only (not to be used with 2 way valve).
To be used with the following controls:
TMV-C, TMV-R-IAQ, TMV-AU-IAQ and WM-TQR.

VERSION	TEC
MODEL	CV - CH - CVB - NC
CODE	9053049



T2 sensor to be placed on the water supply pipe upstream 3 way valves (not to be used with 2 way valve).

The T2 sensor must be used as described below:

- Change-Over for the automatic switch of the operating mode. If water temperature is lower than 20°C, cooling mode is set; on the other hand, if water temperature exceeds 30°C, heating mode is set.
- It can be used on units with electric heater and hot water supply. The T2 priority probe activates the electric heater or water valve, depending on the water temperature detected. If water temperature exceeds 34°C, the water valve ON-OFF control is activated; on the other hand, if water temperature is lower than 30°C, the electric heater is activated.

To be used with the UP-AU power unit.

VERSION	TEC
MODEL	CV - CH - CVB - NC
CODE	9025310

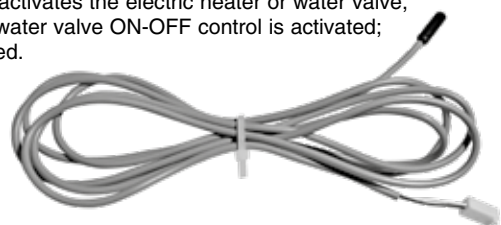

Electronic control accessories for **TEC**

Terminal board adaptor kit

To connect the units CV and CVB with the WM-3V, WM-T, WM-TQR or WM-AU controls, a terminal board adaptor kit is available on request.

VERSION	TEC
MODEL	CV - CVB
IDENTIFICATION	KIT
CODE	9060103

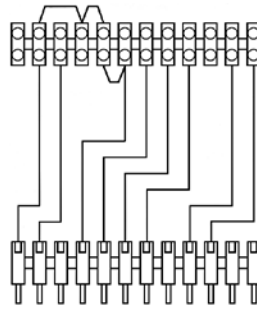

Controls and units **MB** version for **TEC** units

All the **TEC** units can be supplied with a wide range of controls, which allows managing one single unit or several units by using the Modbus RTU - RS 485 communication protocol. Units can be managed according to the Master/Slave logic (up to 20 units) or by supervisory components. The system consists in a **MB** board and a series of controls, such as the **T-MB** control, the **RT03** infra-red remote control, the **PSM-DI** multifunction control and the **NET** supervisory program.

MB electronic board

DESCRIPTION	IDENTIFICATION	CODE
<i>MB electronic board fitted on the unit</i>	<i>MB-M</i>	<i>9066332</i>
<i>MB electronic board supplied with separate packaging</i>	<i>MB-S</i>	<i>9066333</i>

The **MB** electronic board, to be mounted on the fan coil internal unit, is set to carry out different functions and adjustment modes, in order to meet the installation requirements. These modes are selected by setting the configuration dip switches on the board.

- 2/4 pipe system.
- Fan ON/OFF thermostatic control.
- Valve ON/OFF thermostatic control and continuous ventilation.
- Valve and simultaneous ventilation ON/OFF thermostatic control.
- Fan operation control depending on the coil temperature (cut-out T3 probe fitted), which can be activated only in heating mode or heating and cooling mode.
- Automatic switch of the operating mode by means of T2 water probe (optional) applied on the 2 pipe system.
- Seasonal switch by means of remote contact.
- ON/OFF of the fan coil by means of the remote contact (window or clock contact).
- Electric heater control.

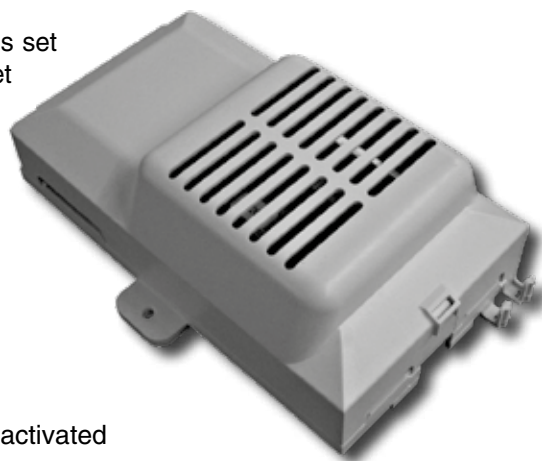

By activating the cut-out T3 probe function, the fan is stopped in winter when the coil temperature is lower than 32°C and started when the temperature reaches 36°C. In summer mode, the fan stops when the temperature inside the coil exceeds 22°C and starts when it drops below 18°C.

The following connections are located on the power board:

- Receiver for infra-red remote control.
- T-MB control.
- RS 485 serial connection to manage several fan coils in Master/Slave configuration or to create a supervisory network.

NTC sensor included for T1 function (return air control).

NTC sensor included for T3 function (low temperature cut-out thermostat).

NTC sensor (option) for T2 function (summer/winter switch).

T-MB control

DESCRIPTION	IDENTIFICATION	CODE
Wall control (to be used with MB board)	T-MB	9066331E
Control fitted on the unit, for CV/CVB models (to be used with MB board only)	T-MB-LM	9066646
Control supplied with separate packaging, for CV/CVB models (to be used with MB board only)	T-MB-LS	9066645
Control fitted on the unit, for CV/CVB models (UP-AU included)	T-MB-M-UP	9066675
Control supplied with separate packaging, for CV/CVB models (UP-AU included)	T-MB-S-UP	9066674

Control with display that allows controlling one or more units in Master/Slave mode. The control is equipped with internal sensor to detect the room temperature, which can be defined as a priority compared to the return air sensor on the fan coil.

The **T-MB** control features the following functions:

- Switch the appliance ON and OFF.
- Temperature set.
- Modify the set point (when used as a +/- 3° variation of the set point configured from NET supervisory program or PSM-DI).
- Set the fan speed (low, medium, high or autofan).
- Set the operation mode (fan only, cooling, heating; auto for 4 pipe systems with mode selection depending on the air temperature).
- Time setting.
- Weekly ON/OFF program.
- Display and change of the fan coil operation parameters.



Dimensions: 110x72x25 mm

RT03 infra-red remote control

DESCRIPTION	IDENTIFICATION	CODE
<i>RT03 infra-red remote control with fitted receiver, for CV / CH / CVB models (to be used with MB board only)</i>	RM-RT03	9066336
<i>RT03 infra-red remote control with receiver supplied with separate packaging (to be used with MB board only)</i>	RS-RT03	9066337
<i>RT03 infra-red remote control supplied with separate packaging (to be used with MB board only)</i>	RT03	3021203
<i>Receiver for RT03 infra-red remote control fitted on the unit, for CV / CH / CVB models (to be used with MB board only)</i>	RM	9066339
<i>Receiver for RT03 infra-red remote control supplied with separate packaging (to be used with MB board only)</i>	RS	9066338

The infra-red remote control allows setting by a remote position the fan coil operation parameters.

The **RT03** infra-red remote control features the following functions:

- Switch the appliance ON and OFF.
- Temperature set.
- Set the fan speed (low, medium, high or autofan).
- Set the operation mode (fan only, cooling, heating; auto for 4 pipe systems with mode selection depending on the air temperature).
- Time setting.
- 24 hours ON/OFF program.



INSTALLATION EXAMPLE
WITH INFRA-RED REMOTE CONTROL

Controls and units **MB** version for **TEC** units

A group of **TEC** units with **MB** electronic board can be connected via a serial link and can consequently be managed at the same time by just one **T-MB** control or **RT03** infra-red remote control. Using the special jumper present on the **MB** board, one unit must be configured as the master, and all the others as slaves. It is clear that the remote control must be pointed at the receiver on the master unit. To avoid problems, it is recommended to install and connect the receiver only on the master unit.

With **T-MB** control

One control for each unit
(MAXIMUM LENGTH OF THE CONNECTION CABLE = 20 m)



One control for more units (20 units max.)
(MAXIMUM TOTAL LENGTH OF THE CONNECTION CABLE = 800 m)

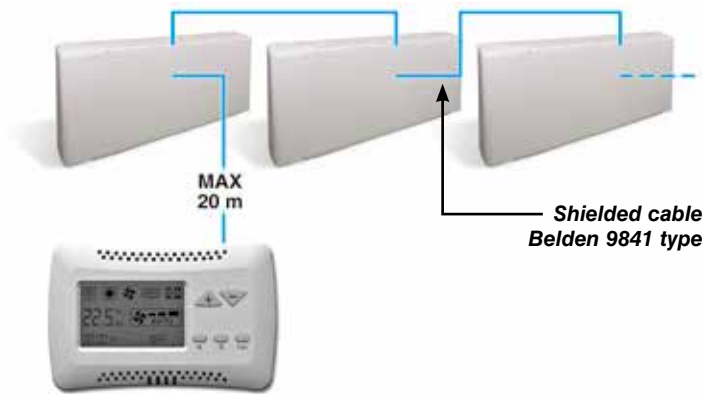

With **RT03** infra-red remote control

One control for each unit



One control for more units (20 units max.)
(MAXIMUM TOTAL LENGTH OF THE CONNECTION CABLE = 800 m)

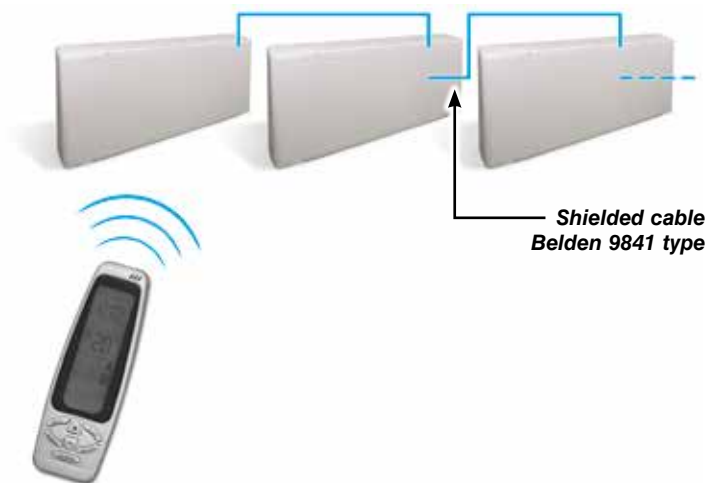

T2 accessory for units with MB electronic board

IDENTIFICATION	CODE
T2	9025310

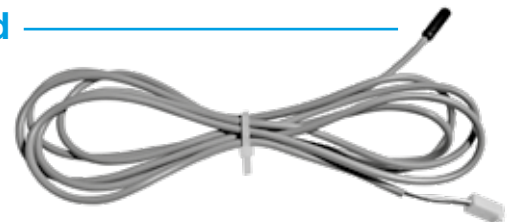

The T2 sensor can be combined with MB boards to be placed on the water supply pipe upstream 3 way valves (not to be used with 2 way valve).

The T2 sensor must be used as described below:

- Change-Over for 2-pipe system for the automatic switch of the operating mode.
If water temperature is lower than 20°C, cooling mode is set; on the other hand, if water temperature exceeds 30°C, heating mode is set.
- It can be used on units with electric heater and hot water supply. The T2 priority probe activates the electric heater or water valve, depending on the water temperature detected. If water temperature exceeds 34°C, the water valve ON-OFF control is activated; on the other hand, if water temperature is lower than 30°C, the electric heater is activated.

PSM-DI multifunction control panel

DESCRIPTION	IDENTIFICATION	CODE
<i>Multifunction control (to be used with MB board only)</i>	PSM-DI	3021293

Another option available for the serial communication between the units is the possibility to connect up to 60 **TEC** units in series and manage them with just one wall mounted **PSM-DI** controller. The wall mounted controller can be used to set the operating mode for each individual unit connected, display the operating conditions of each individual unit, and set the ON/OFF time sets for each day of the week (the program can be set for all the units and for a maximum of ten groups of units).

If more than 60 units need to be connected, two or more control panels must be used. Each unit must have a MB board. The **PSM-DI** control is used to manage a series of fan coils, up to a maximum of 60 units (the maximum length of the RS 485 connection cable must not exceed 800 m), from one single control point.

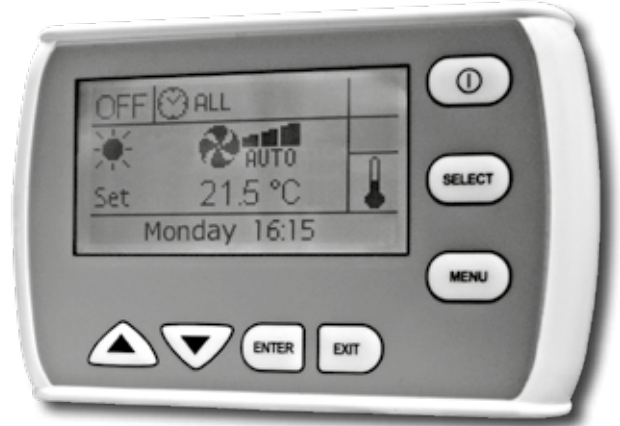

The **PSM-DI** control communicates via a serial line with all the units connected, with the possibility of controlling them all together or individually. In fact, the unique address of each individual fan coil means that all the units can be called at the same time, or the individual unit called, to perform the following functions:

- display the current operating mode, the fan speed, the set point;
- display the room temperature measured on the individual unit;
- turn all the units ON and OFF at the same time or alternatively each unit individually;
- change the operating mode (fan only, heating, cooling, automatic changeover);
- change the set point;
- modify the values and operation parameters of the fan speed.

Each function can then be sent to all the units connected, or alternatively to each individual unit.

Different set points or operating modes can be set for each individual unit.

The **PSM-DI** panel can also be used for the time management of the units over the week. Four ON times and four OFF times can be set on the units for each day of the week. A different temperature set that will be considered as Operation set for all connected appliances, can be set for each event. If the temperature set is not entered for the individual event, it must be set during programming for each individual unit or for the entire network.

Units without receiver or with receiver can be connected within the network: the former can receive instructions only from the **PSM-DI** wall mounted panel; while the latter can receive information from both the wall mounted panel (**PSM-DI**) and infra-red remote control. Use the infra-red remote control to force ON mode of the individual unit, if ON/OFF daily time programming has been set. The unit will regain the settings from the **PSM-DI** panel during execution of successive start-up program.

The PSM-DI panel cannot be used together with the NET management program (see next page).

Notes:

- set the Dip Switches of each fan coil as illustrated in the remote control installation manual, based on the required solutions.
- it is possible to connect only one single SIOS board per each PSM-DI control panel.
- about "Priority pump function": when just one unit calls for, the relay RL1 on the SIOS board is automatically activated to connect a hot water pump.
- the RS 485 network's overall length must not exceed 700/800 metres.

NET program for managing a network of MB fan coils

DESCRIPTION	IDENTIFICATION	CODE
Hardware/software supervisory system (to be used with MB board only)	NET	9079118

NET is a centralised control system for networks of MB fan coils, based on software that runs on LINUX™ operating system (the program is provided pre-installed on a PC) and it works in a “stand alone” way, as an ordinary computer, so that it can be connected to a monitor, to a mouse and to a keyboard. By connecting an Ethernet cable is instead possible to work at a distance and visualize the entire program setting-up through whatever browsers. The **NET** software offers a practical and economical solution for managing the units, with the simple click of the mouse.

The main characteristics include:

- simplicity of use;
- an extremely complete and functional weekly program;
- possibility to access the historical operating data for each individual unit connected;
- possibility to save automatically every 6 h the data on SD support and to force the saving with a button;
- possibility of data saving also on other items, as for example USB key;
- visualization of the saved configuration on a new ASUS PC.

The program exploits all the potential of our units with remote controls, representing an addition to the latter.

The **NET** program is a control tool that can be used as a replacement for the remote control, or in parallel, however the settings made using **NET** can have priority over those made using the remote control.

The program can be used to:

- Create uniform groups (groups of units on individual floors, in offices or rooms).
- Save weekly programs configured for different types of operation (summer, winter, mid seasons, closing periods etc.); these can then be recalled and activated with a simple click of the mouse. Weekly on/off cycles can be set for individual units or groups of units.
- Set the operating conditions for each individual unit or groups of units (operating mode, fan speed, temperature setting).
- Set the set point limits for each individual unit or groups of units.
- Switch each individual unit or groups of units ON or OFF.



Management system for a network of **TEC** units

The main program screen can display and interact with the entire network of units. An individual unit, a group of units or the entire network can be called so as to make modifications to the operating mode and the set point. The user can then check the operating status of each individual unit, read the room temperature, the coil temperature and the operating status of the condensate drain pump or any alarms.

“MONITORING” SCREEN



Displaying a unit

The “MONITORING” SCREEN shows the units that are connected to the network and scanned by the program.

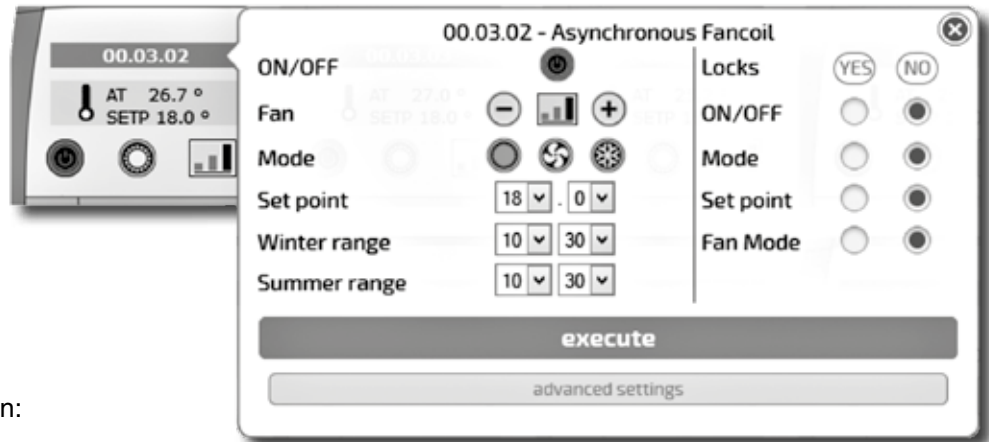

The icon of the terminal unit provides the following information:

- Unit name (**00.03.02**)
- Set temperature (SETP)
- Room temperature (AT)
- Unit status: ON (Green) or OFF (Red)
- Mode:
 - Summer
 - Winter
 - Fan only
 - Auto
- Fan speed:
 - Low
 - Medium
 - High
 - Fan

Management system for a network of **TEC** units

The “Weekly Program” can be used to set the unit operating parameters for each day of the week. Several weekly programs can be set.



Time bands are available for each day of the week. The time and the type of operation to be performed by the unit can be set for each band. The time and the operating parameters can then be displayed before being sent to the unit and implemented.

Displaying of the parameters and Dip Switches set up

Every time that the reading of the set up Dip Switches results not easy (as for example by the false ceiling installations), it is always possible to display them directly through the NET program.

Group: gruppo 1	FW release: 0.50	Program: gruppo 1 inverno	
Remote control: N.A.	M/S network: N.A.	Unit tree: Level 2 --> Router 1	
Unit status: ON	Mode: WINTER	Fan mode: AUTO	Fan status: OFF
Set Point: 22.0°	Heating status: OFF	Cooling status: [OFF]	Inverter voltage: 0.2
T1: 22.5°	T2: N.A.	T3: 28.5°	
Pump: YES	Remote ON/OFF input: OFF	Window input: OFF	

Unit settings		Alarms
Dip Switch:	OFF ON	
<input type="checkbox"/>	1 2 pipe unit	T1 Fault OFF
<input type="checkbox"/>	2 Thermal station with valves	T2 Fault OFF
<input type="checkbox"/>	3 T3 disabled	T3 Fault OFF
<input type="checkbox"/>	4 T3 only winter when enabled	
<input checked="" type="checkbox"/>	5 Simultaneous ventilation of valves	Condensation OFF
<input type="checkbox"/>	6 Unit without electrical heater	
<input type="checkbox"/>	7 T2 as CH Change-over (resistance phase II)	
<input type="checkbox"/>	8 UNIT ALERT	
<input type="checkbox"/>	9 Remote ON/OFF input	
<input type="checkbox"/>	10 MASTER	

Management system for a network of **TEC** units

Alarm control by E-mail and sms

In addition to the alarm set on the NT display, it is possible to send the ON-OFF alarm notification via E-mail and sms.

ALARMS

Ongoing alarms

At	Address	Unit name	Group	Alarm type
No alarms				

Alarms log

From	To	Address	Unit name	Group	Alarm type
No alarms					

Notification

Event type	eMail						SMS					
	none	instant	after 1 hour	after 3 hours	after 6 hours	at the end	none	instant	after 1 hour	after 3 hours	after 6 hours	at the end
Alarm on unit [any]	<input checked="" type="radio"/>	<input type="radio"/>	<input type="radio"/>	<input type="radio"/>	<input type="radio"/>	<input type="checkbox"/>	<input checked="" type="radio"/>	<input type="radio"/>	<input type="radio"/>	<input type="radio"/>	<input type="radio"/>	<input type="checkbox"/>
Condensate alarm on unit	<input checked="" type="radio"/>	<input type="radio"/>	<input type="radio"/>	<input type="radio"/>	<input type="radio"/>	<input type="checkbox"/>	<input checked="" type="radio"/>	<input type="radio"/>	<input type="radio"/>	<input type="radio"/>	<input type="radio"/>	<input type="checkbox"/>
Probe alarm on unit	<input checked="" type="radio"/>	<input type="radio"/>	<input type="radio"/>	<input type="radio"/>	<input type="radio"/>	<input type="checkbox"/>	<input checked="" type="radio"/>	<input type="radio"/>	<input type="radio"/>	<input type="radio"/>	<input type="radio"/>	<input type="checkbox"/>

Save

RS 485 serial connection cable

Shielded cable to be used:

Belden 9841, RS-485, 1x2x24 AWG SFTP, 120 Ohm



PC NET Software

Connection of a **TEC** network with MB electronic board

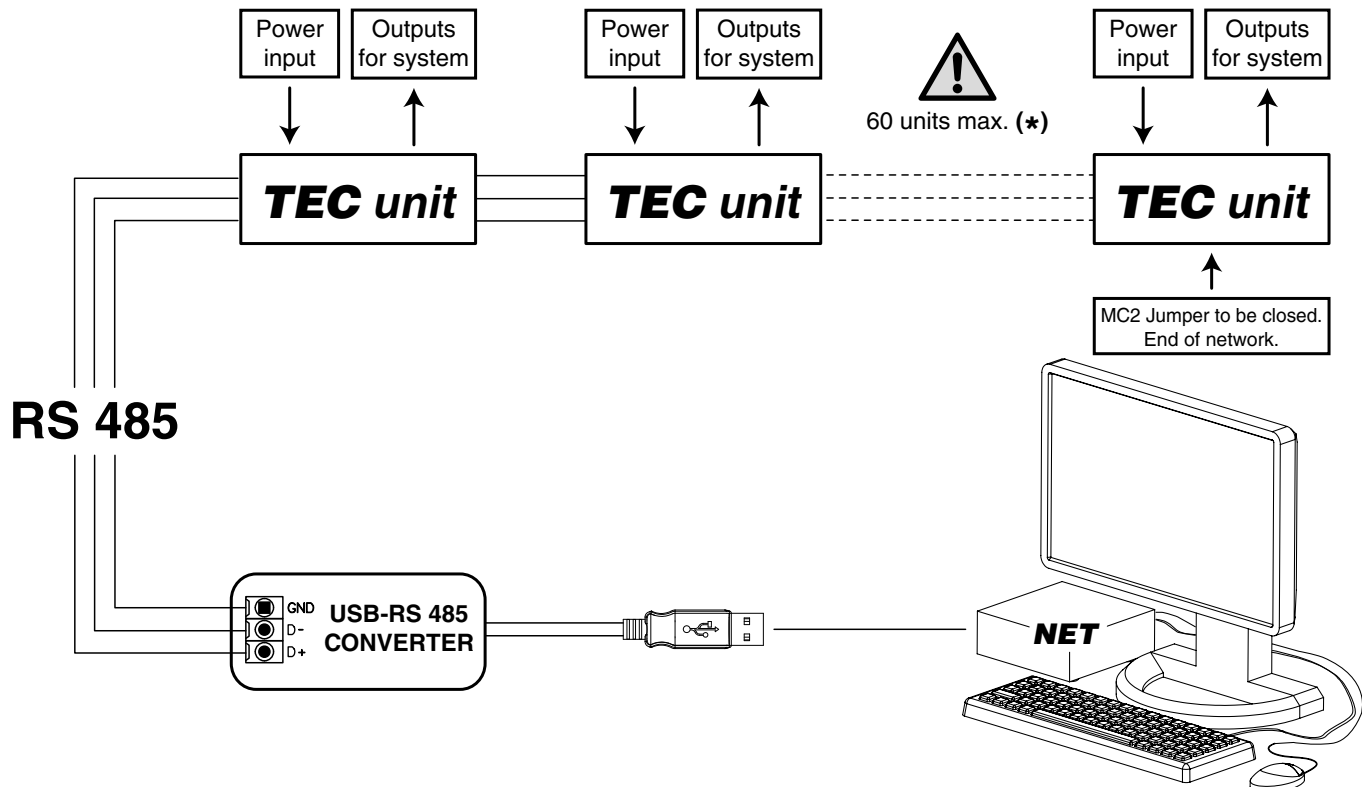

(*) In the event of more than 60 units, add one or more Router-S (see next page).

PSM-DI and NET electronic boards for TEC units

IDENTIFICATION	CODE
<i>SIOS</i>	<i>3021292</i>

SIOS is a board equipped with 8 relays with potential free contact to control the activation or deactivation of remote electric utilities. Moreover, the board has 8 digital inlets to display the actuators or external consents, such as motor or other.

The SIOS boards can be connected:

- inside a network managed by NET;
- to a PSM-DI panel (one SIOS for each PSM-DI panel).



IDENTIFICATION	CODE
<i>Router-S</i>	<i>3021290</i>

The Router-S is an electronic board that allows to control several units inside a network managed by NET (default) or within a sub-network managed by BMS systems, that are not provided by us (it is necessary to operate on a Dip Switch on the board).

Managed by NET

The Router-S in the standard version is an electronic board that:

- allows creating networks with more than 60 units (minimum 2 Router-S are required) or to divide the network (per floor, building, etc.);
- allows creating a Master/Slave sub-network to be controlled as an independent group.

The number of Router-S to be used is:

- up to 60 units: no Router-S
- from 61 to 120 units: 2 Router-S
- every 60 subsequent units: 1 additional Router-S

Managed by BMS Systems which are not provided by us

The Router-S becomes an electronic board to use with BMS systems not supplied by us, only after having set the Dip Switch on the board and so creating a Master/Slave sub-network to be controlled as an independent group.

The number of Router-S to use is:

- maximum 14 Router-S
- maximum 15 Fan Coils per Router-S



The descriptions and illustrations provided in this publication are not binding: we reserve the right, whilst maintaining the essential characteristics of the types described and illustrated, to make, at any time, without the requirement to promptly update this piece of literature, any changes that it considers useful for the purpose of improvement or for any other manufacturing or commercial requirements.

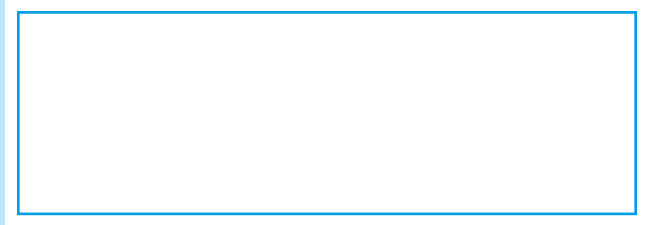

TEC - 11/18

Cod. 99ATEC0100 A/11/18