



Neptun

Air handling units
for swimming pools and spas

TECHNICAL LEAFLET

Neptun

Air handling units for swimming pools and SPA



The Neptun air handling units are specifically designed to dehumidificate and assure a correct confort level inside the indoor swimming pools.

The study and engineering of the Neptun units led to: high attention to details, high quality components, internal protection against chlorine aggression, a specified regulation for swimming pools application and always provided with the unit; these features make these air handling units ideal for the indoor swimming pools in every application: from private villas to SPAs, from rehabilitation pools to the swimming ones.

Both the recovery unit and the whole Neptun air handling unit are Eurovent certified..



The Neptun units are made of an aluminium frame and 45 mm panels with insulation of mineral wool with density of 100 kg/m^3 , internal anti-corrosion protection, glass microfiber filters and frame of polypropylene, in addition to:

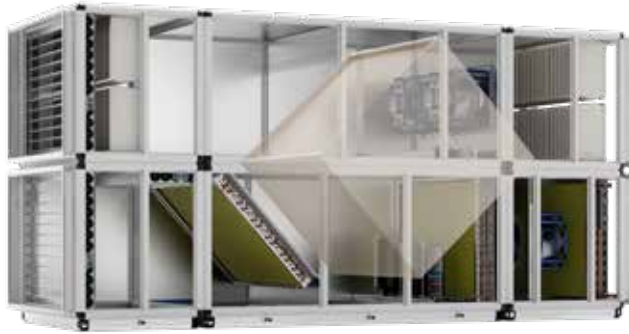

Recovery unit made of polypropylene, designed on purpose in order to resist to aggressive chemicals and for hygienic systems.



Plug fans with IE5 efficiency, highly efficient and with integrated speed regulation.

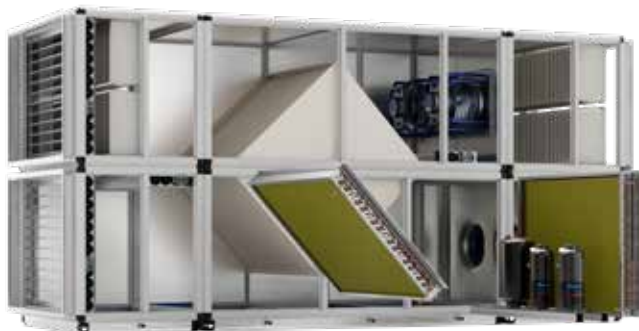

Heat pump, where provided, with compressor based on inverter technology (for power supplies higher than 2 kW) evaporator coil and condenser coil made of lamellar aluminium panels with epoxy protection and drawn copper tubes. The solution with heat pump assures an elevated energy saving.

All the units in every configuration are completely regulated, equipped with a touch user terminal that allows an easy setup of the control parameters and they let the access from a distance via cloud, perfect to view and modify the unit parameters from a distance.

Moreover, additional condenser coils are provided as accessories in order to pre-heat the water of the swimming pool and the sanitary one.

Neptun V and Neptun-V HP compact vertical units

The **Neptun-V** units, thanks to their compact configuration, allow to be installed in technical rooms where the unit dimension is decisive, as it happens for example in case of recovery of existing locals for the construction of a SPA area or of a rehabilitation swimming pool.

The recovery section with double cross-flow plate heat exchanger allows to have an efficient unit despite the reduced dimensions.

The **Neptun-V HP** units are equipped inside with a heat pump for the thermodynamic recovery, that leads to a further dehumidification of the recirculated air and pre-heats the air supplied towards the swimming pool room.

Neptun-V

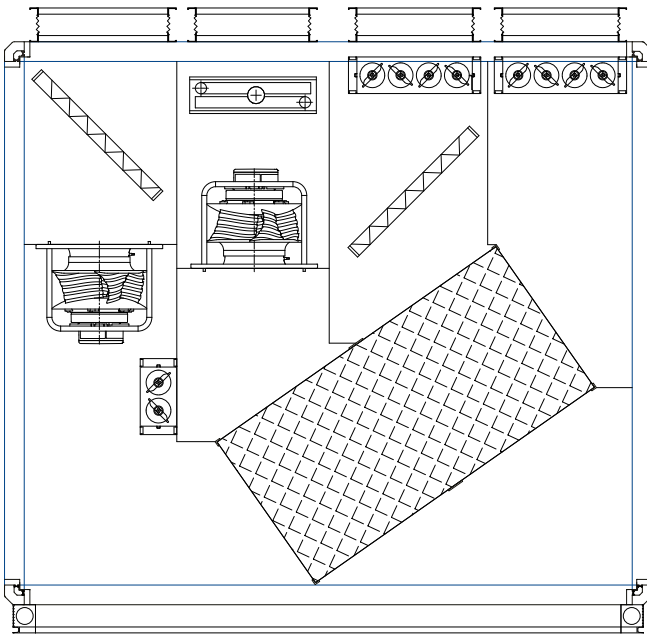

Air handling unit air flow diagram

air flow rate V (m³/h)

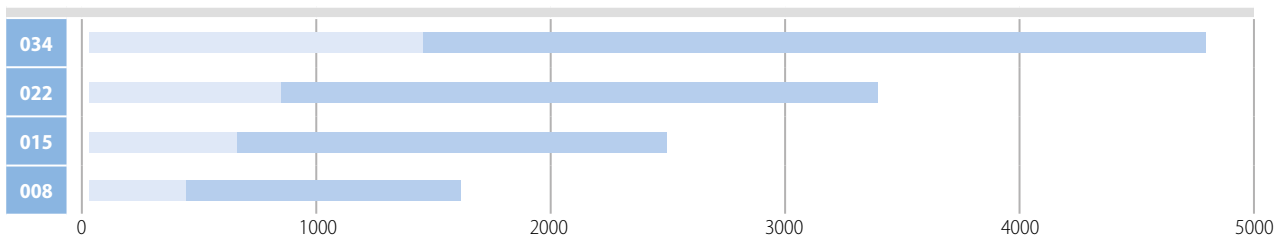

Unit type	Min	Nom	Max
	m ³ /h	m ³ /h	m ³ /h
008	450	800	1600
015	650	1500	2500
022	850	2200	3400
034	1450	3400	4800

Neptun-V HP

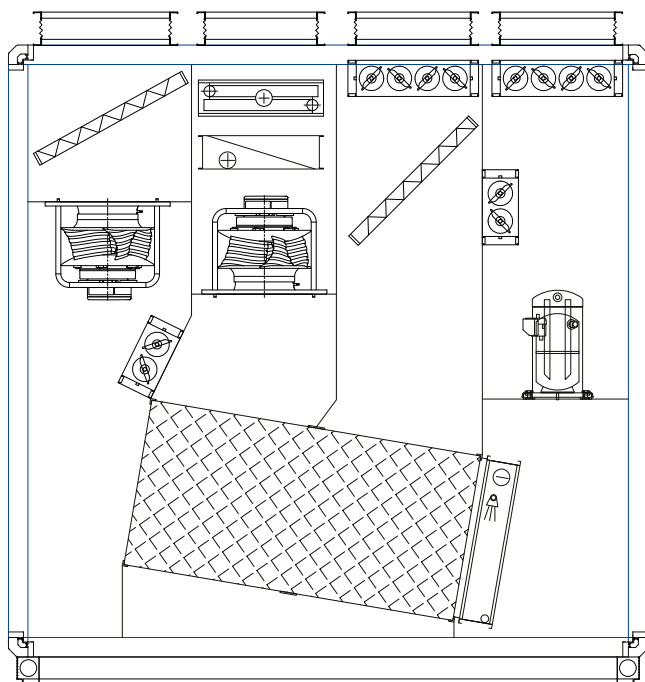

Air handling unit air flow diagram

air flow rate V (m³/h)

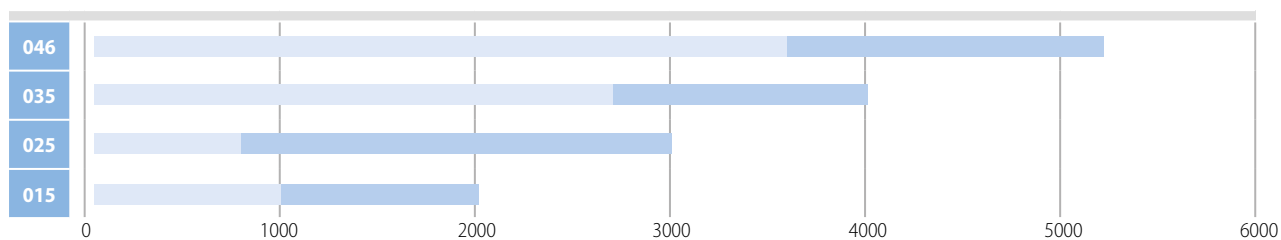

Unit type	Min	Nom	Max
	m ³ /h	m ³ /h	m ³ /h
015	1000	1500	2000
025	1800	2500	3000
035	2700	3500	4000
046	3600	4600	5200

Neptun and Neptun HP units

The **Neptun** units allow to manage higher air flow rates and to have better performances in terms of air dehumidification. They are ideal to be integrated in swimming pool systems with larger surface and wider rooms.

The recovery section with cross-flow plate allows to assure high recovery efficiency thanks to the reduced transit speeds.

The **Neptun HP** units are equipped inside with a heat pump for the thermodynamic recovery, that leads to a further dehumidification of the recirculated air and pre-heats the air supplied towards the swimming pool room.

Neptun

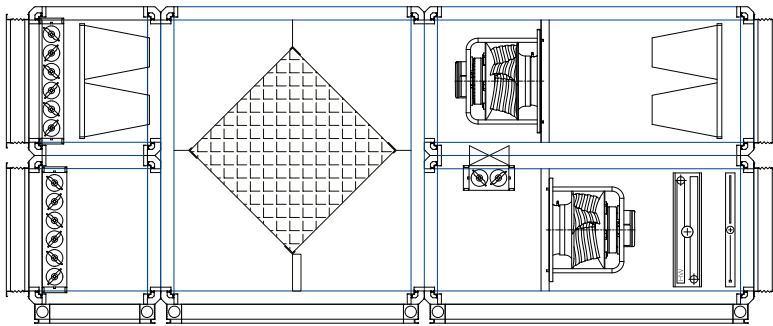

Air handling unit air flow diagram

air flow rate V (m³/h)

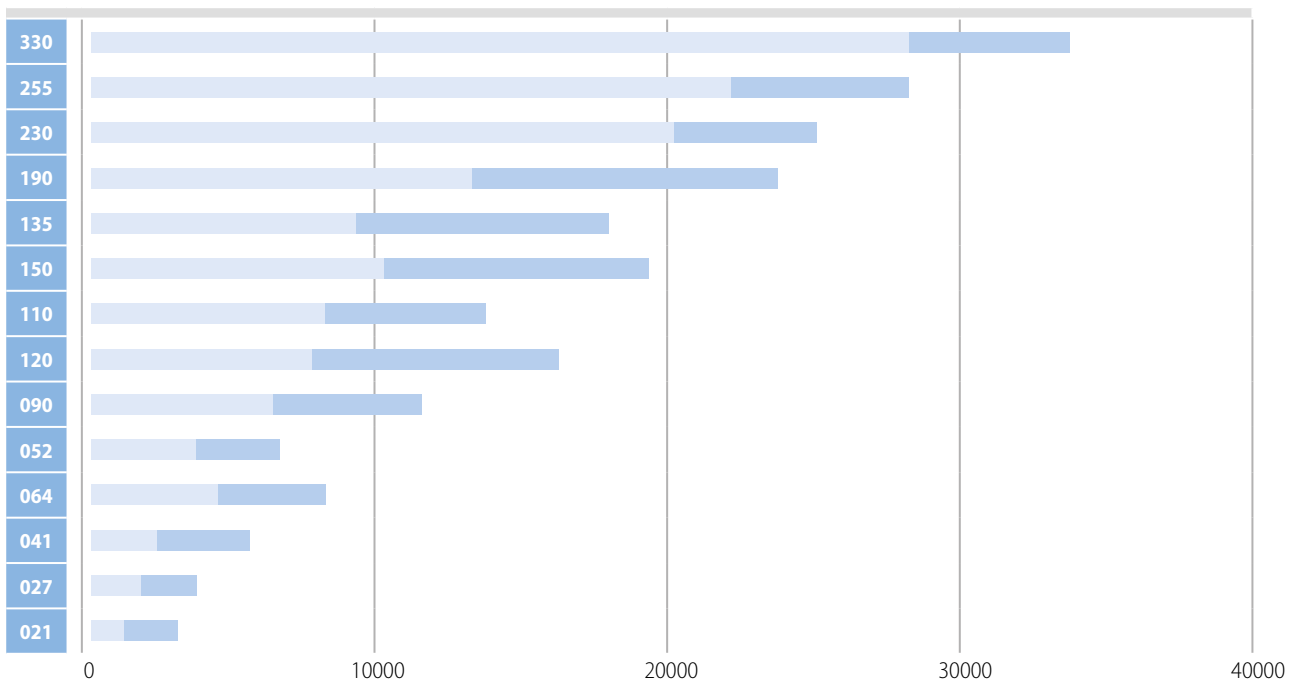

Unit type	Min	Nom	Max
	m ³ /h	m ³ /h	m ³ /h
021	1200	2100	3000
027	1800	2700	3700
041	2300	4100	5600
064	4400	6400	8000
052	3800	5200	6600
090	6400	9000	11200
120	7600	12000	16000

Unit type	Min	Nom	Max
	m ³ /h	m ³ /h	m ³ /h
110	8000	11000	13500
150	10000	15000	19000
135	9000	13500	17600
190	13000	19000	23400
230	20000	23000	25000
255	22000	25500	28000
330	28000	33000	33500

Neptun HP

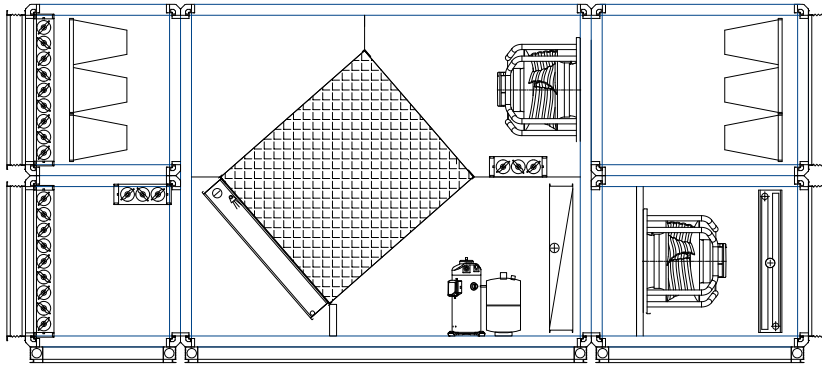

Air handling unit air flow diagram

air flow rate V (m³/h)

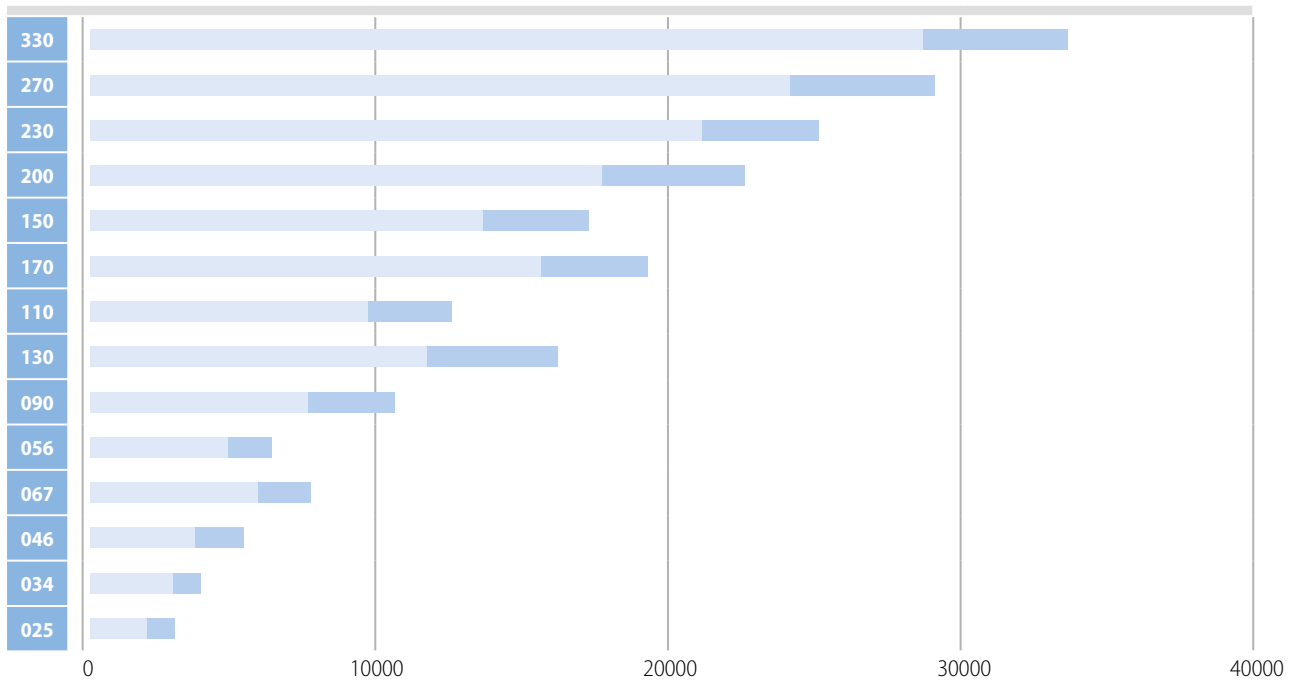

Unit type	Min	Nom	Max
	m ³ /h	m ³ /h	m ³ /h
025	2000	2500	3000
034	2800	3400	3800
046	3600	4600	5200
067	5900	6700	7500
056	4800	5600	6200
090	7500	9000	10500
130	11500	13000	16000

Unit type	Min	Nom	Max
	m ³ /h	m ³ /h	m ³ /h
110	9500	11000	12500
170	15500	17000	19000
150	13500	15000	17000
200	17500	20000	22500
230	21000	23000	25000
270	24000	27000	29000
330	28500	33000	33500

Neptun



A company of Arbonia Group
ARBONIA ▲

Follow us



Sabiana app



SABIANA SpA

Società a socio unico

Via Piave 53 - 20011 Corbetta (MI) Italia

T. +39 02 97203 1 r.a. • F. +39 02 9777282

info@sabiana.it

www.sabiana.it