

SEC-ECM Fan Coil Units

HP-ECM High Pressure Fan Coil Units

SEC/HP-ECM

INTRODUCTION

SEC and **HP** fan coils combine a beautiful design with very interesting performances in terms of sound level and energy consumption. The **ECM** models are available in five different models, for wall and ceiling installation, with casing and concealed.

The **ECM** range makes use of the excellent experience gained with the Cassette fan coils with inverter board, first in the world in production since 2009, and which have had great success on all markets.

The innovative brushless and sensorless type synchronous electronic motor with permanent magnets, is controlled by an **inverter** board designed and developed in Italy. The board is mounted on the unit, closed to the motor, without the need to be cooled down by the air flow.

The air flow rate can be varied **in continuous** by means of a 1-10 V signal generated by our controls or by independent control systems. The continuous air flow control improves the acoustic comfort and allows a more punctual reply to the variation of the thermal loads and a greater stability of the requested ambient temperature.

The extreme efficiency, also at low speed, makes possible a great reduction in electric consumption (less than 50% in comparison to SEC and HP range motor) with absorption values under normal operating conditions that **do not exceed 16 Watt for SEC-ECM models and do not exceed 50 Watt for HP-ECM models** on the entire range. The excellent values of the SEC and HP range in terms of sound levels have been maintained **in all working conditions**, without any resonance phenomenon at any frequency.

The full compliance with the Electromagnetic Compatibility Directive and with the other severe Standards in force is certified by an independent institute.

CONTENTS

• SEC-ECM version

- Construction *Page 4*
- Models *Page 5*
- Dimensions, Weight, Water content *Page 6*
- Technical features *Page 10*
- Operation limits *Page 13*
- Emission tables *Page 14*
- Correction factors table *Page 24*
- Water pressure drop *Page 25*

• HP-ECM version

- Construction features *Page 26*
- Dimensions, Weight, Water content *Page 28*
- Technical features *Page 30*
- Main performance and technical characteristics *Page 32*
- Operation limits *Page 33*
- Emission tables *Page 34*
- Correction factors tables *Page 40*
- Water pressure drop *Page 42*

• SEC-ECM / HP-ECM version

- Accessories *Page 44*
- **ECM** configuration *Page 61*
- Electronic controls to be fitted *Page 62*
- Electronic controls *Page 63*
- Controls and units **MB version** *Page 65*
- Management system for a network of fan coils *Page 70*
- PSM-DI and NET electronic boards *Page 74*

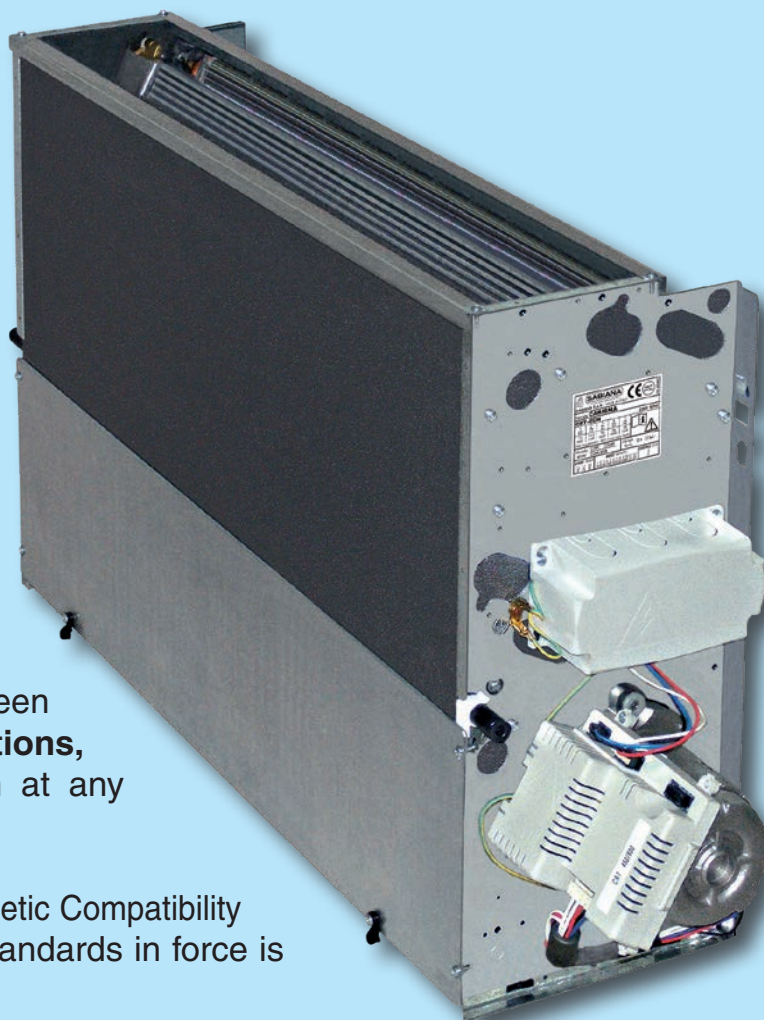

SEC-ECM version with centrifugal fan

Range includes 5 air flow rates (from 115 to 1395 m³/h) and 5 models (for wall and ceiling installation, with casing and concealed), each equipped with 3 or 4 row coil and with the possibility to add a 1 or 2 row coil for 4 pipe systems.

It is the most comprehensive range, perfect to meet all air-conditioning requirements of work environments like offices, shops, restaurants and hotel rooms.

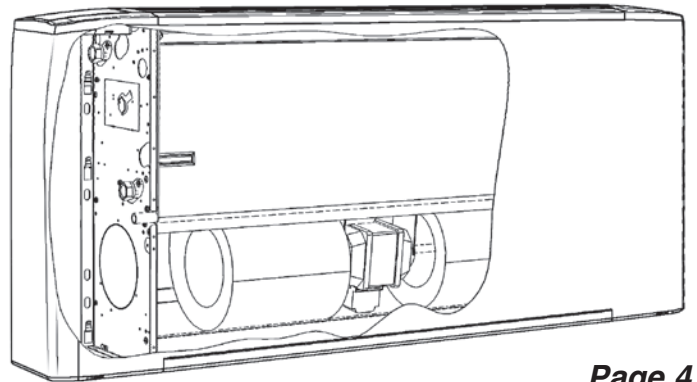

Page 4

**Plastic
outlet grid
in one single piece:
extraordinary
design and strength**



HP-ECM version with high pressure centrifugal fan

Range includes 3 air flow rates (from 350 to 1450 m³/h), each equipped with 3 or 4 row coil and with the possibility to add a 1 or 2 row coil for 4 pipe systems.

It is the most comprehensive range, perfect to meet all air-conditioning requirements of work environments like offices, shops, restaurants and hotel rooms featuring ducted installations with available pressure up to 80 Pa.

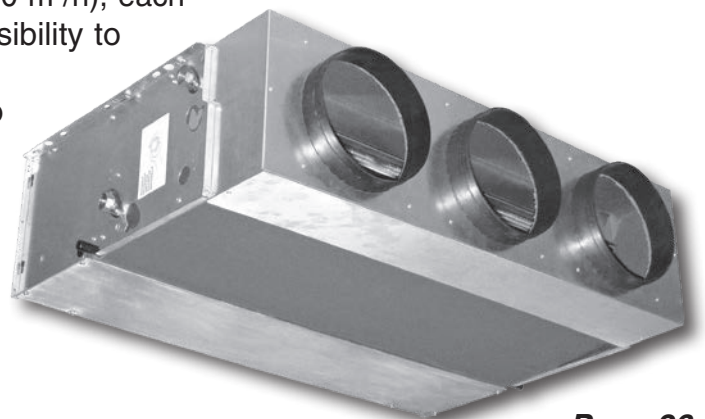

Page 26

Construction

Outer casing

Made of galvanized and pre-painted steel casing.

The plastic top grid has fixed louvres and is reversible in order to distribute the air in two different directions.

Standard colours:

- Top grid: **Pantone 427C (light grey)**

- Casing: **RAL 9003 (white)**
- Other colours on request.

Inner casing

Made from 1 mm galvanized steel insulated with 3 mm polyolefin (PO) foam (class M1).

Filter

Polypropylene cellular fabric regenerating filter.

The filter frame of galvanized steel is inserted into special plastic sliding guides fastened to the internal structure for easy insertion and removal of the filter.

Filter presence is highlighted by a plastic front cover featuring the same colour as the top grid.

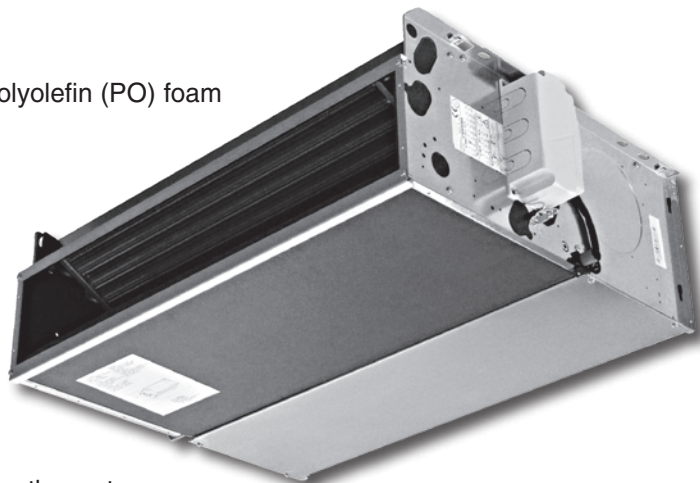

Fan assembly

The fans have aluminium or plastic blades directly keyed on the motor with double aspiration and they are dynamically and statically balanced during manufacture in order to have an extremely quiet operation.

Electronic motor

Three phase permanent magnet brushless electronic motor that is controlled with reconstructed current according to a BLAC sinusoidal wave. The inverter board that controls the motor operation is powered by 230 Volt, single-phase and, with a switching system, it generates a three-phase frequency modulated, wave form power supply. The electric power supply required for the machine is therefore single-phase with voltage of 230-240V and frequency of 50-60Hz.

Coil

It is manufactured from drawn copper tube and the aluminium fins are mechanically bonded onto the tube by an expansion process. The coil has two 1/2inch BSP internal connections and 1/8 inch BSP air vent and drain. The coil is not suitable for use in corrosive atmosphere or in environments where aluminium may be subject to corrosion.

The connections are on the left side facing the unit. On request we can deliver the unit with the connections on the right end side. This operation can also be easily carried out on site during installation.

Condensate collection tray

Made of plastic (ABS UL94 HB) with a "L-shaped" plastic fitted on the inner casing; in the CH, CVB and NC model the tray is insulated with 3 mm polyolefin (PO) foam (class M1). The outside diameter of the condensate discharge pipe is 15mm.

Accessories and Controls

See page 44 and 62.



Models

CV

Vertical Casing – Wall Installation

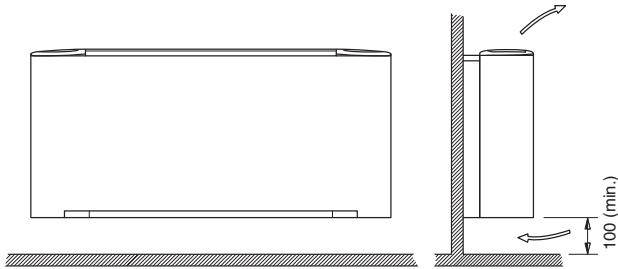

CV

Vertical Casing – Ceiling Installation

NOTE: the CV model can also be installed horizontally leaving behind a 100 mm gap for air intake.

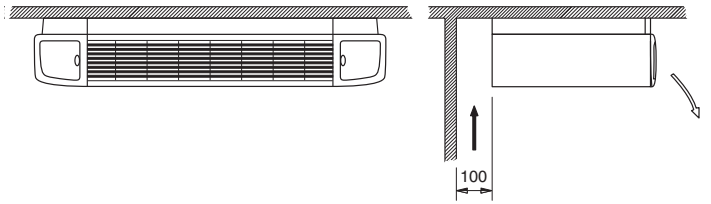

CVB

Vertical Casing – Floor Installation

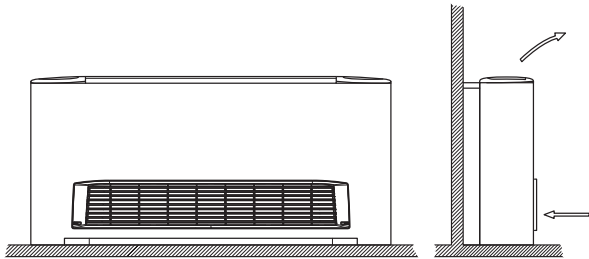

CH

Horizontal Casing

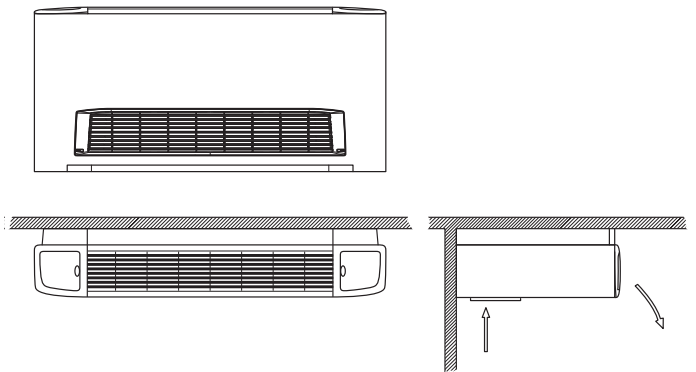

NC

Vertical Concealed

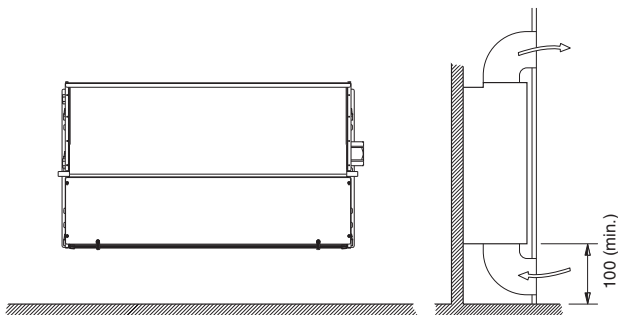

NC

Horizontal Concealed

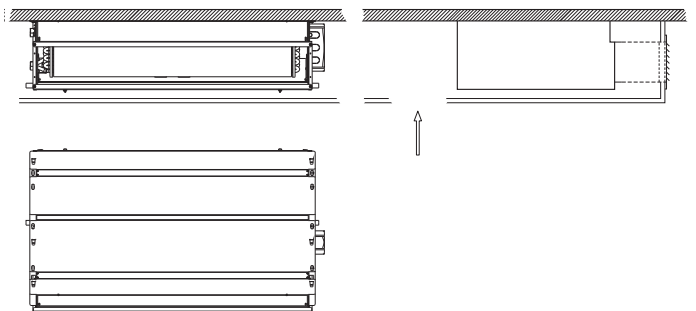

Dimension, Weight, Water content

CV

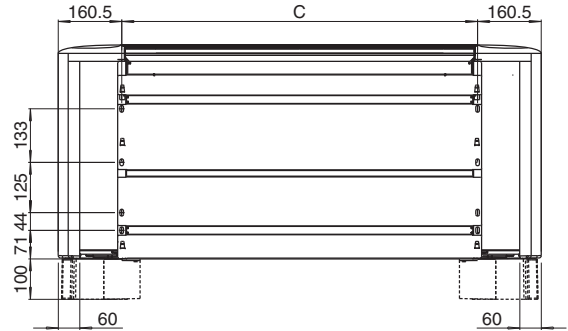
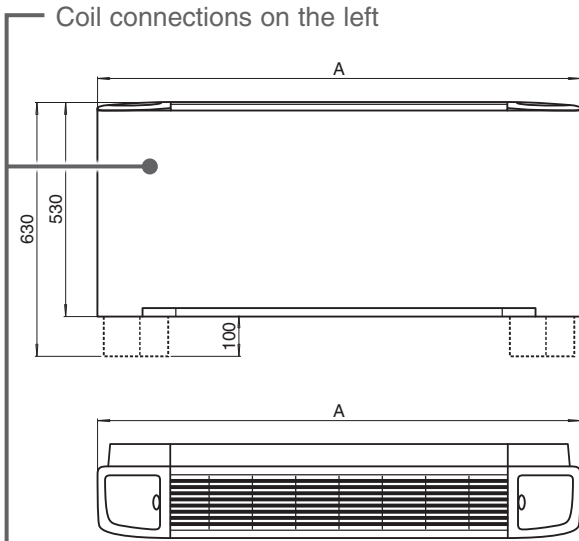

Feet (optional)

CH-CVB

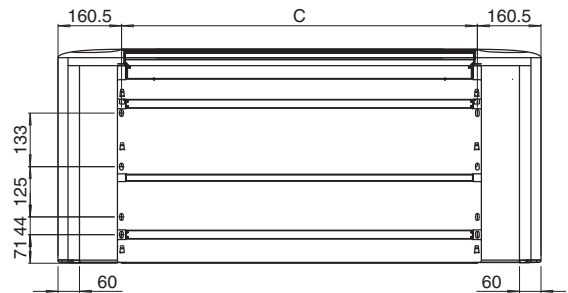
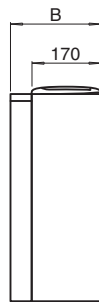
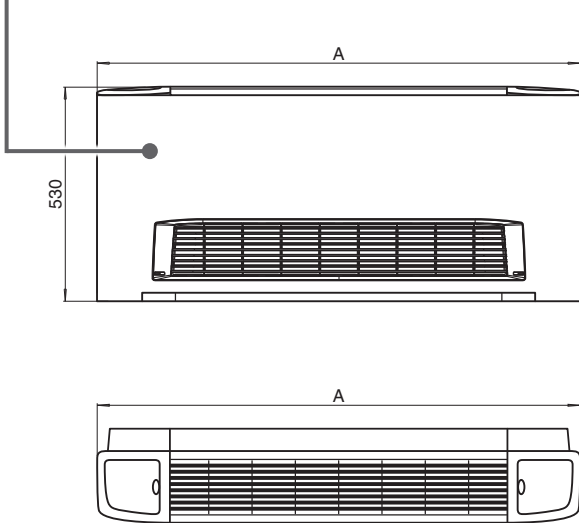

COIL CONNECTIONS

3 or 4 row coils

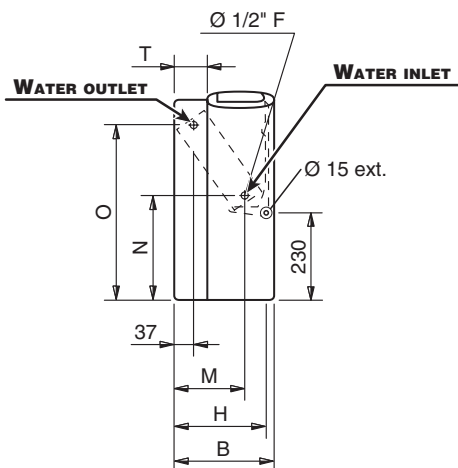

Heating additional coil (1 or 2 rows)

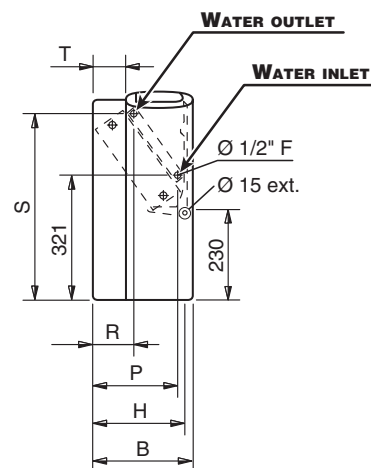

Dimension, Weight, Water content

PACKAGING

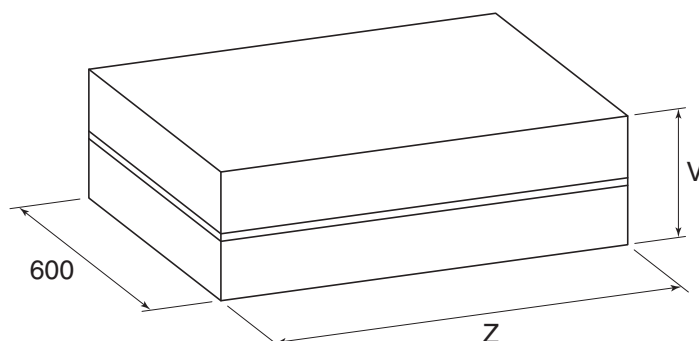

Dimension (mm)

MODEL	2	4	6	7	9
A	775	990	1205	1420	1420
B	225	225	225	225	255
C	454	669	884	1099	1099
H	205	205	205	205	235
M	145	145	145	145	170
N	260	260	260	260	270
O	460	460	460	460	450
P	185	185	185	185	210
R	105	105	105	105	110
S	475	475	475	475	465
T	55	55	55	55	85
V	260	260	260	260	290
Z	820	1035	1250	1465	1465

Weight (kg)

		Weight with packaging					Weight without packaging				
MODEL		2	4	6	7	9	2	4	6	7	9
Rows	3	17,2	22,5	27,7	32,1	35,9	15,4	20,2	24,9	28,8	32,2
	3+1	18,0	23,7	29,2	33,9	37,7	16,2	21,4	26,4	30,6	34,0
	3+2	18,6	24,4	30,1	35,0	38,8	16,8	22,1	27,3	31,7	35,1
	4	18,0	23,5	29,0	33,6	37,4	16,2	21,2	26,2	30,3	33,7
	4+1	18,8	24,7	30,5	35,4	39,2	17,0	22,4	27,7	32,1	35,5

Water content (litres)

MODEL	2	4	6	7	9	
Rows	3	0,6	0,9	1,6	1,7	1,9
	4	0,8	1,3	2,2	2,4	2,8
	+1	0,2	0,3	0,5	0,5	0,6
	+2	0,4	0,6	1,0	1,0	1,2

Dimension, Weight, Water content

NC Vertical Installation

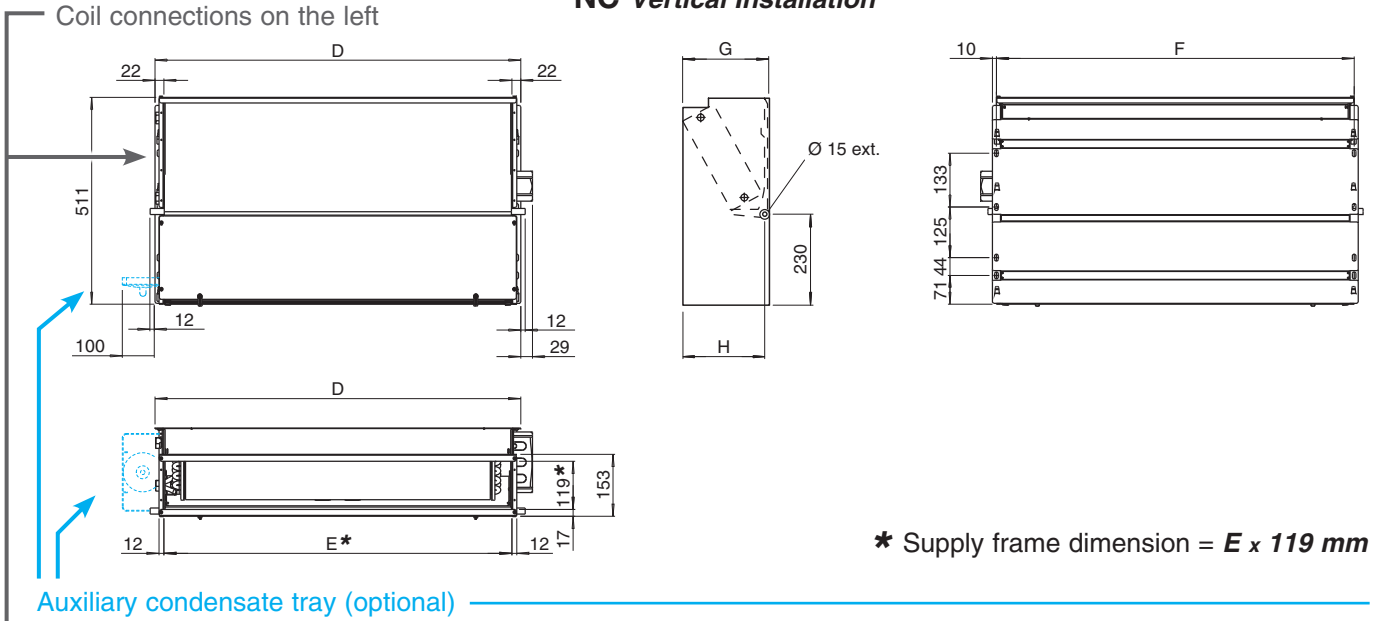

NC Horizontal Installation

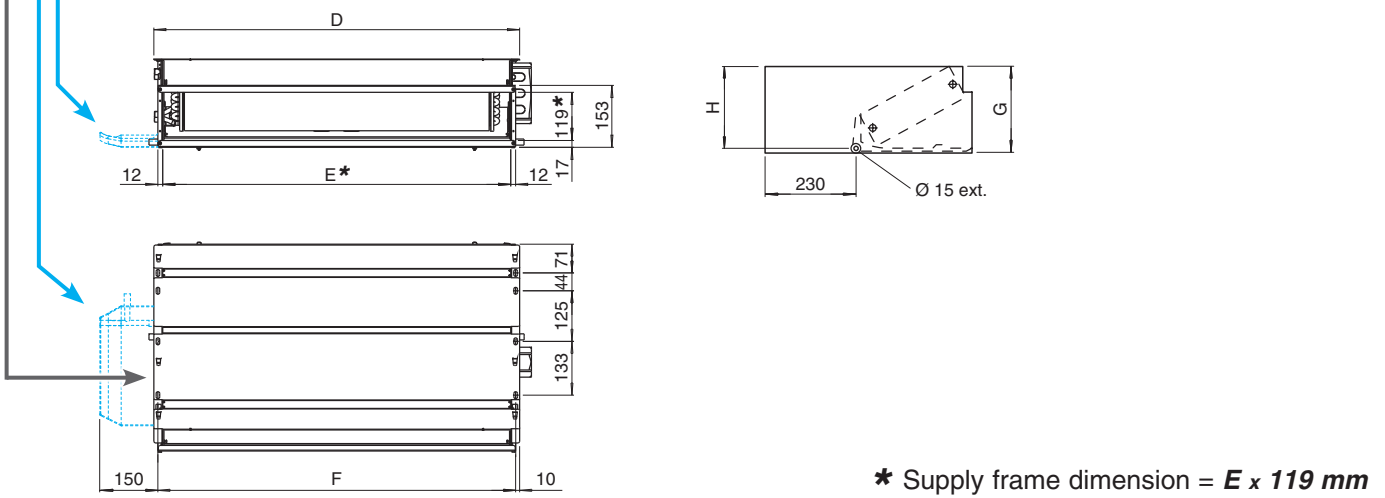

COIL CONNECTIONS

3 or 4 row coils

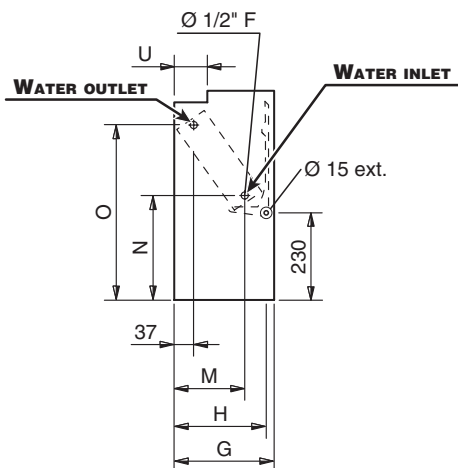

Heating additional coil (1 or 2 rows)

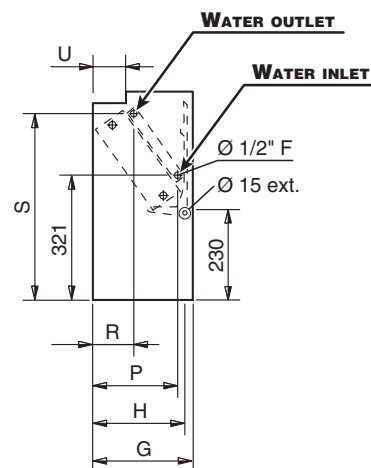

Dimension, Weight, Water content

PACKAGING

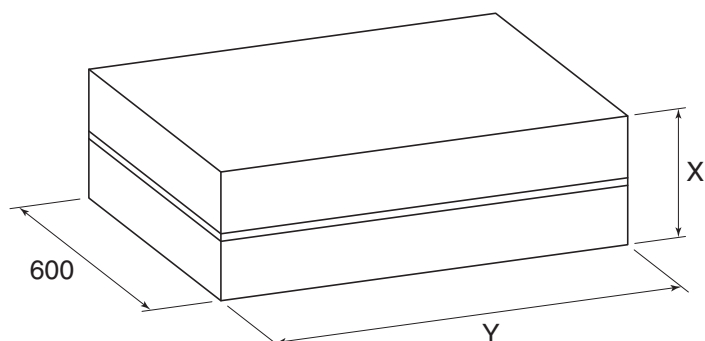

Dimension (mm)

MODEL	2	4	6	7	9
D	474	689	904	1119	1119
E	430	645	860	1075	1075
F	454	669	884	1099	1099
G	218	218	218	218	248
H	205	205	205	205	235
M	145	145	145	145	170
N	260	260	260	260	270
O	460	460	460	460	450
P	185	185	185	185	210
R	105	105	105	105	110
S	475	475	475	475	465
U	65	65	65	65	95
X	260	260	260	260	290
Y	820	820	1035	1250	1250

Weight (kg)

		Weight with packaging					Weight without packaging				
MODEL		2	4	6	7	9	2	4	6	7	9
Rows	3	13,6	18,1	22,8	27,0	30,4	11,8	16,3	20,5	24,2	27,3
	3+1	14,4	19,3	24,3	28,8	32,2	12,6	17,5	22,0	26,0	29,1
	3+2	15,0	20,0	25,2	29,9	33,3	13,2	18,2	22,9	27,1	30,2
	4	14,4	19,1	24,1	28,5	31,9	12,6	17,3	21,8	25,7	28,8
	4+1	15,2	20,3	25,6	30,3	33,7	13,4	18,5	23,3	27,5	30,6

Water content (litres)

MODEL	2	4	6	7	9	
Rows	3	0,6	0,9	1,6	1,7	1,9
	4	0,8	1,3	2,2	2,4	2,8
	+1	0,2	0,3	0,5	0,5	0,6
	+2	0,4	0,6	1,0	1,0	1,2

Technical features

SEC-ECM UNITS WITH 3 ROW COIL

2 pipe units.

The following standard rating conditions are used:

COOLING

Entering air temperature +27°C d.b. +19°C w.b.
Water temperature +7°C E.W.T. +12°C L.W.T.

HEATING

Entering air temperature +20°C
Water temperature +45°C E.W.T. +40°C L.W.T.

MODEL		SEC-ECM 2.3-2T					SEC-ECM 4.3-2T					SEC-ECM 6.3-2T					
		1	3	5	7,5	10	1	3	5	7,5	10	1	3	5	7,5	10	
Speed		MIN		MED		MAX	MIN		MED		MAX	MIN		MED		MAX	
Inverter power																	
Air flow	m ³ /h	120	170	220	270	330	210	280	350	430	515	305	395	495	610	735	
Cooling total emission	kW	0,73	0,97	1,18	1,37	1,59	1,41	1,80	2,18	2,57	2,95	1,96	2,44	2,93	3,44	3,96	
Cooling sensible emission	kW	0,55	0,74	0,92	1,09	1,28	1,03	1,33	1,64	1,95	2,26	1,46	1,83	2,22	2,64	3,08	
Heating	kW	0,77	1,04	1,29	1,52	1,80	1,42	1,84	2,26	2,69	3,14	1,96	2,46	3,00	3,55	4,14	
Dp Cooling	kPa	2,2	3,6	5,1	6,7	8,6	7,9	12,0	17,0	22,6	28,9	5,5	8,0	11,1	14,8	19,0	
Dp Heating	kPa	1,6	2,7	3,9	5,2	7,0	6,6	10,4	14,9	20,4	26,7	4,5	6,8	9,6	12,9	17,0	
Fan	W	7,0	9,0	11,0	15,0	21,0	6,0	9,0	12,0	17,0	25,0	7,0	10,0	15,0	22,0	32,0	
Sound power	Lw dB(A)	30	36	41	47	51	30	36	42	47	51	33	38	44	49	54	
Sound pressure (*)	Lp dB(A)	21	27	32	38	42	21	27	33	38	42	24	29	35	40	45	

MODEL		SEC-ECM 7.3-2T					SEC-ECM 9.3-2T				
		1	3	5	7,5	10	1	3	5	7,5	10
Speed		MIN		MED		MAX	MIN		MED		MAX
Inverter power											
Air flow	m ³ /h	400	500	610	755	890	605	785	945	1175	1395
Cooling total emission	kW	2,60	3,13	3,68	4,36	4,94	3,45	4,22	4,82	5,60	6,26
Cooling sensible emission	kW	1,92	2,33	2,77	3,32	3,80	2,63	3,28	3,79	4,49	5,10
Heating	kW	2,56	3,13	3,72	4,43	5,08	3,74	4,65	5,41	6,46	7,38
Dp Cooling	kPa	10,5	14,5	19,4	26,1	32,6	8,9	12,7	16,1	21,1	25,9
Dp Heating	kPa	8,5	12,1	16,4	22,2	28,3	7,3	10,7	14,0	19,1	24,2
Fan	W	9,0	13,0	18,5	28,5	41,0	16,0	25,0	41,0	65,0	99,0
Sound power	Lw dB(A)	37	43	48	53	57	44	50	55	60	64
Sound pressure (*)	Lp dB(A)	28	34	39	44	48	35	41	46	51	55

(*) = The sound pressure levels are 9 dB(A) lower than the sound power levels and apply to the reverberant field of a 100 m³ room and a reverberation time of 0.5 sec.

Technical features

SEC-ECM UNITS WITH 4 ROW COIL

2 pipe units.

The following standard rating conditions are used:

COOLING

Entering air temperature +27°C d.b. +19°C w.b.
Water temperature +7°C E.W.T. +12°C L.W.T.

HEATING

Entering air temperature +20°C
Water temperature +45°C E.W.T. +40°C L.W.T.

MODEL		SEC-ECM 2.4-2T					SEC-ECM 4.4-2T					SEC-ECM 6.4-2T				
Inverter power		1	3	5	7,5	10	1	3	5	7,5	10	1	3	5	7,5	10
Speed		MIN		MED		MAX	MIN		MED		MAX	MIN		MED		MAX
Air flow	m ³ /h	115	160	210	260	325	200	265	340	415	505	290	375	475	590	720
Cooling total emission	kW	0,77	1,06	1,32	1,57	1,86	1,43	1,83	2,27	2,71	3,17	2,05	2,59	3,19	3,84	4,51
Cooling sensible emission	kW	0,56	0,78	0,98	1,19	1,42	1,03	1,34	1,67	2,02	2,39	1,48	1,89	2,34	2,84	3,38
Heating	kW	0,78	1,08	1,37	1,65	1,98	1,42	1,83	2,30	2,77	3,32	2,02	2,59	3,23	3,93	4,68
Dp Cooling	kPa	3,2	5,5	8,0	11,0	14,8	4,0	6,1	8,9	12,3	16,1	8,2	12,4	17,8	24,8	33,0
Dp Heating	kPa	2,6	4,7	7,1	9,9	13,6	3,1	4,9	7,3	10,2	13,7	6,6	10,3	15,1	21,4	29,1
Fan	W	7,0	8,8	11,0	14,6	21,0	6,0	9,0	12,0	17,0	25,0	7,0	10,0	15,0	22,0	32,0
Sound power	Lw dB(A)	30	36	41	47	51	30	36	42	47	51	33	38	44	49	54
Sound pressure (*)	Lp dB(A)	21	27	32	38	42	21	27	33	38	42	24	29	35	40	45

MODEL		SEC-ECM 7.4-2T					SEC-ECM 9.4-2T				
Inverter power		1	3	5	7,5	10	1	3	5	7,5	10
Speed		MIN		MED		MAX	MIN		MED		MAX
Air flow	m ³ /h	380	475	585	735	875	575	755	910	1145	1365
Cooling total emission	kW	2,61	3,20	3,82	4,61	5,30	3,59	4,49	5,21	6,18	7,04
Cooling sensible emission	kW	1,90	2,34	2,82	3,44	3,99	2,69	3,40	3,99	4,81	5,53
Heating	kW	2,57	3,17	3,84	4,66	5,43	3,76	4,81	5,63	6,84	7,93
Dp Cooling	kPa	7,3	10,5	14,3	20,0	25,6	6,3	9,3	12,1	16,4	20,8
Dp Heating	kPa	5,9	8,6	12,0	16,9	22,0	5,6	8,7	11,4	16,1	20,9
Fan	W	9,0	13,0	18,5	28,5	41,0	16,0	25,0	41,0	65,0	99,0
Sound power	Lw dB(A)	37	43	48	53	57	44	50	55	60	64
Sound pressure (*)	Lp dB(A)	28	34	39	44	48	35	41	46	51	55

(*) = The sound pressure levels are 9 dB(A) lower than the sound power levels and apply to the reverberant field of a 100 m³ room and a reverberation time of 0.5 sec.

Technical features

SEC-ECM UNITS WITH 1 ROW ADDITIONAL COIL

4 pipe units.

The following standard rating conditions are used:

COOLING

Entering air temperature +27°C d.b. +19°C w.b.
Water temperature +7°C E.W.T. +12°C L.W.T.

HEATING

Entering air temperature +20°C
Water temperature +65°C E.W.T. +55°C L.W.T.

MODEL		SEC-ECM 2.3-4T					SEC-ECM 4.3-4T					SEC-ECM 6.3-4T				
		1	3	5	7,5	10	1	3	5	7,5	10	1	3	5	7,5	10
Speed		MIN		MED		MAX	MIN		MED		MAX	MIN		MED		MAX
Inverter power																
Air flow	m ³ /h	120	170	220	270	330	210	280	350	430	515	305	395	495	610	735
Cooling total emission	kW	0,73	0,97	1,18	1,37	1,59	1,41	1,80	2,18	2,57	2,95	1,96	2,44	2,93	3,44	3,96
Cooling sensible emission	kW	0,55	0,74	0,92	1,09	1,28	1,03	1,33	1,64	1,95	2,26	1,46	1,83	2,22	2,64	3,08
Heating	kW	0,71	0,91	1,08	1,24	1,43	1,29	1,57	1,85	2,13	2,41	1,76	2,10	2,45	2,83	3,22
Dp Cooling	kPa	2,3	3,8	5,4	7,2	9,4	7,3	11,5	16,0	21,6	28,1	6,4	9,6	13,2	17,7	23,3
Dp Heating	kPa	1,0	1,6	2,1	2,7	3,5	3,6	5,2	6,9	8,8	11,0	1,2	1,7	2,2	2,9	3,6
Fan	W	7,0	9,0	11,0	14,5	21,0	6,0	9,0	12,0	17,0	25,0	7,0	10,0	15,0	22,0	32,0
Sound power	Lw dB(A)	30	36	41	47	51	30	36	42	47	51	33	38	44	49	54
Sound pressure (*)	Lp dB(A)	21	27	32	38	42	21	27	33	38	42	24	29	35	40	45

MODEL		SEC-ECM 7.3-4T					SEC-ECM 9.3-4T				
		1	3	5	7,5	10	1	3	5	7,5	10
Speed		MIN		MED		MAX	MIN		MED		MAX
Inverter power											
Air flow	m ³ /h	400	500	610	755	890	605	785	945	1175	1395
Cooling total emission	kW	2,60	3,13	3,68	4,36	4,94	3,45	4,22	4,82	5,60	6,26
Cooling sensible emission	kW	1,92	2,33	2,77	3,32	3,80	2,63	3,28	3,79	4,49	5,10
Heating	kW	2,33	2,72	3,12	3,63	4,06	2,99	3,58	4,05	4,69	5,24
Dp Cooling	kPa	9,7	13,8	18,4	24,8	31,8	8,9	12,7	16,1	21,1	25,9
Dp Heating	kPa	2,4	3,1	4,0	5,2	6,3	3,7	5,1	6,3	8,2	9,9
Fan	W	9,0	13,0	18,5	28,5	41,0	16,0	25,0	41,0	65,0	99,0
Sound power	Lw dB(A)	37	43	48	53	57	44	50	55	60	64
Sound pressure (*)	Lp dB(A)	28	34	39	44	48	35	41	46	51	55

(*) = The sound pressure levels are 9 dB(A) lower than the sound power levels and apply to the reverberant field of a 100 m³ room and a reverberation time of 0.5 sec.

Operation limits

Highest water inlet temperature..... + 85 °C

Lowest water inlet temperature..... + 5 °C

for entering water temperatures below + 5°C, contact the technical department

Highest working pressure..... 1000 kPa (10 bars)

Note: For CH model the maximum installation height is 2,8 m.

On heating it must be payed attention to rooms where the floor temperature is particularly low (for example less than 5°C).

In this situation the floor can cool the lower layer of air to a level that can stop the uniform diffusion of the hot air coming from the unit.

Water flow limits for 3 row coil (l/h)

MODEL	SEC-ECM 2.3	SEC-ECM 4.3	SEC-ECM 6.3	SEC-ECM 7.3	SEC-ECM 9.3
Lowest	100	100	150	150	200
Highest	500	750	1000	1500	2000

Water flow limits for 4 row coil (l/h)

MODEL	SEC-ECM 2.4	SEC-ECM 4.4	SEC-ECM 6.4	SEC-ECM 7.4	SEC-ECM 9.4
Lowest	100	150	150	200	300
Highest	750	1000	1500	2000	2250

Water flow limits for 1 row additional coil (l/h)

MODEL	SEC-ECM 2	SEC-ECM 4	SEC-ECM 6	SEC-ECM 7	SEC-ECM 9
Lowest	50	50	100	100	100
Highest	250	350	500	650	750

Water flow limits for 2 row additional coil (l/h)

MODEL	SEC-ECM 2	SEC-ECM 4	SEC-ECM 6	SEC-ECM 7	SEC-ECM 9
Lowest	50	100	100	100	100
Highest	250	350	500	650	750

Motor electrical data (max. absorption)

MODEL		SEC-ECM 2	SEC-ECM 4	SEC-ECM 6	SEC-ECM 7	SEC-ECM 9
230/1 50Hz	W	21,0	25,0	32,0	41,0	99,0
	A	0,18	0,22	0,28	0,34	0,81

Cooling emission of 3 row coil

Entering air temperature: 27°C – R.H.: 50%

MODEL ECM	Vdc	WT: 7/12 °C					WT: 8/13 °C					WT: 10/15 °C					WT: 12/17 °C				
		Qv m³/h	Pc kW	Ps kW	Qw l/h	Dp(c) kPa	Pc kW	Ps kW	Qw l/h	Dp(c) kPa	Pc kW	Ps kW	Qw l/h	Dp(c) kPa	Pc kW	Ps kW	Qw l/h	Dp(c) kPa			
SEC 2.3	10	330	1,72	1,27	299	7,9	1,53	1,19	266	6,4	1,12	1,04	196	3,7	0,90	0,90	159	2,5			
	7,5	270	1,49	1,08	258	6,1	1,32	1,02	230	4,9	0,98	0,88	171	2,9	0,77	0,77	135	1,9			
	5	220	1,27	0,91	220	4,6	1,13	0,86	196	3,7	0,84	0,74	147	2,2	0,66	0,66	115	1,4			
	3	170	1,04	0,74	181	3,3	0,93	0,69	162	2,7	0,70	0,60	121	1,6	0,53	0,53	93	1,0			
	1	120	0,79	0,55	137	2,0	0,71	0,52	123	1,6	0,53	0,45	93	1,0	0,39	0,39	69	0,6			
SEC 4.3	10	515	3,17	2,25	550	32,9	2,84	2,11	493	27,0	2,14	1,84	373	16,3	1,62	1,62	283	9,9			
	7,5	430	2,76	1,94	478	25,8	2,48	1,82	429	21,2	1,88	1,59	326	12,8	1,40	1,40	243	7,6			
	5	350	2,35	1,63	406	19,3	2,11	1,53	365	15,9	1,60	1,33	278	9,7	1,18	1,18	204	5,6			
	3	280	1,93	1,33	334	13,7	1,74	1,25	300	11,3	1,33	1,08	229	6,9	0,96	0,96	167	3,9			
	1	210	1,52	1,03	262	8,9	1,37	0,97	236	7,4	1,05	0,84	181	4,6	0,74	0,74	129	2,5			
SEC 6.3	10	735	4,26	3,07	738	21,6	3,81	2,89	661	17,6	2,86	2,52	498	10,6	2,21	2,21	386	6,7			
	7,5	610	3,70	2,63	641	16,8	3,32	2,48	574	13,8	2,50	2,16	434	8,3	1,90	1,90	331	5,1			
	5	495	3,15	2,21	544	12,6	2,82	2,08	488	10,3	2,14	1,81	370	6,3	1,59	1,59	277	3,7			
	3	395	2,62	1,83	453	9,1	2,36	1,71	407	7,5	1,79	1,49	310	4,6	1,32	1,32	229	2,7			
	1	305	2,12	1,46	365	6,3	1,90	1,37	329	5,2	1,45	1,19	251	3,2	1,05	1,05	182	1,8			
SEC 7.3	10	890	5,31	3,79	921	37,1	4,04	3,56	702	30,4	3,60	3,11	627	18,5	2,74	2,74	478	11,3			
	7,5	755	4,69	3,31	812	29,7	4,21	3,11	729	24,4	3,20	2,71	555	14,9	2,39	2,39	416	8,8			
	5	610	3,96	2,76	684	22,0	3,56	2,60	615	18,1	2,71	2,26	470	11,1	1,99	1,99	346	6,4			
	3	500	3,37	2,33	581	16,5	3,03	2,19	523	13,6	2,32	1,90	400	8,4	1,69	1,69	292	4,8			
	1	400	2,79	1,92	482	11,9	2,52	1,80	434	9,8	1,93	1,57	333	6,1	1,38	1,38	240	3,4			
SEC 9.3	10	1395	6,76	5,06	1180	30,3	6,01	4,76	1051	24,7	4,43	4,17	780	14,6	3,63	3,63	642	10,4			
	7,5	1175	6,05	4,46	1051	24,7	5,39	4,20	938	20,2	3,99	3,67	698	12,0	3,21	3,21	563	8,2			
	5	945	5,19	3,77	900	18,8	4,64	3,55	804	15,4	3,46	3,10	602	9,3	2,71	2,71	474	6,1			
	3	785	4,55	3,27	787	14,8	4,07	3,07	704	12,2	3,05	2,68	529	7,4	2,35	2,35	409	4,6			
	1	605	3,72	2,63	642	10,4	3,33	2,47	575	8,6	2,51	2,15	434	5,2	1,90	1,90	330	3,1			

Correction factors for different R.H.

R.H.	WT:	7/12°C	8/13°C	10/15°C	12/17°C
48%	Pc	0,95	0,94	1,00	1,00
	Ps	1,00	1,00	1,00	1,00
46%	Pc	0,90	0,88	1,00	1,00
	Ps	1,00	1,00	1,00	1,00

LEGEND

- WT = Water temperature
- Pc = Cooling total emission
- Ps = Cooling sensible emission
- Qw = Water flow
- Dp(c) = Water pressure drop
- Vdc = Inverter Power
- Qv = Air flow

Cooling emission of 3 row coil

Entering air temperature: 26°C – R.H.: 50%

MODEL ECM	Vdc	WT: 7/12 °C					WT: 8/13 °C					WT: 10/15 °C					WT: 12/17 °C				
		Qv	Pc	Ps	Qw	Dp(c)	Pc	Ps	Qw	Dp(c)	Pc	Ps	Qw	Dp(c)	Pc	Ps	Qw	Dp(c)			
		m³/h	kW	kW	l/h	kPa	kW	kW	l/h	kPa	kW	kW	l/h	kPa	kW	kW	l/h	kPa			
SEC 2.3	10	330	1,52	1,19	265	6,4	1,33	1,12	232	5,0	0,99	0,99	173	3,0	0,82	0,82	145	2,1			
	7,5	270	1,32	1,02	229	4,9	1,15	0,95	201	3,9	0,84	0,84	147	2,2	0,70	0,70	123	1,6			
	5	220	1,13	0,86	195	3,7	0,99	0,80	172	3,0	0,69	0,69	121	1,6	0,60	0,60	105	1,2			
	3	170	0,93	0,70	161	2,7	0,82	0,65	142	2,1	0,57	0,56	100	1,1	0,48	0,48	85	0,8			
	1	120	0,70	0,52	122	1,6	0,62	0,48	108	1,3	0,44	0,41	77	0,7	0,36	0,36	63	0,5			
SEC 4.3	10	515	2,82	2,12	490	26,9	2,49	1,98	433	21,5	1,78	1,70	311	11,8	1,48	1,48	259	8,5			
	7,5	430	2,46	1,83	426	21,1	2,18	1,71	377	16,9	1,57	1,47	272	9,4	1,28	1,28	223	6,5			
	5	350	2,10	1,54	362	15,8	1,86	1,44	323	12,7	1,34	1,24	233	7,1	1,08	1,08	187	4,8			
	3	280	1,73	1,25	298	11,2	1,53	1,17	265	9,0	1,11	1,01	193	5,1	0,88	0,88	153	3,3			
	1	210	1,36	0,97	234	7,3	1,20	0,91	208	5,9	0,88	0,78	153	3,4	0,68	0,68	118	2,1			
SEC 6.3	10	735	3,79	2,89	658	17,6	3,34	2,71	580	14,0	2,37	2,33	413	7,6	2,02	2,02	353	5,7			
	7,5	610	3,30	2,48	571	13,7	2,91	2,32	504	11,0	2,08	2,00	361	6,0	1,74	1,74	302	4,3			
	5	495	2,81	2,08	485	10,3	2,48	1,95	429	8,2	1,78	1,68	309	4,6	1,46	1,46	253	3,2			
	3	395	2,34	1,72	404	7,5	2,07	1,61	358	6,0	1,50	1,38	260	3,4	1,21	1,21	209	2,3			
	1	305	1,89	1,37	326	5,1	1,68	1,28	289	4,1	1,22	1,10	211	2,3	0,96	0,96	167	1,5			
SEC 7.3	10	890	4,74	3,57	822	30,4	4,19	3,34	727	24,3	3,00	2,88	523	13,4	2,50	2,50	437	9,7			
	7,5	755	4,19	3,12	725	24,3	3,70	2,92	642	19,5	2,67	2,51	464	10,9	2,18	2,18	381	7,6			
	5	610	3,54	2,60	611	18,0	3,13	2,53	542	14,5	2,27	2,10	394	8,2	1,82	1,82	317	5,5			
	3	500	3,01	2,19	520	13,6	2,67	2,05	462	10,9	1,95	1,77	337	6,2	1,54	1,54	268	4,1			
	1	400	2,50	1,80	431	9,8	2,22	1,69	383	7,9	1,63	1,45	281	4,5	1,27	1,27	220	2,9			
SEC 9.3	10	1395	6,00	4,77	1048	24,5	5,25	4,47	920	19,5	3,96	3,96	699	12,0	3,30	3,30	585	8,8			
	7,5	1175	5,37	4,21	934	20,0	4,71	3,94	821	16,0	3,50	3,50	613	9,6	2,92	2,92	513	7,0			
	5	945	4,61	3,56	801	15,3	4,06	3,33	705	12,2	2,96	2,96	515	7,0	2,47	2,47	432	5,1			
	3	785	4,05	3,08	700	12,1	3,56	2,88	617	9,7	2,52	2,48	438	5,3	2,15	2,15	373	3,9			
	1	605	3,31	2,48	572	8,5	2,92	2,32	505	6,8	2,08	1,99	361	3,7	1,74	1,74	302	2,6			

Correction factors for different R.H.

R.H.	WT:	7/12°C	8/13°C	10/15°C	12/17°C
48%	Pc	0,95	0,94	1,00	1,00
	Ps	1,00	1,00	1,00	1,00
46%	Pc	0,90	0,88	1,00	1,00
	Ps	1,00	1,00	1,00	1,00

LEGEND

- WT = Water temperature
- Pc = Cooling total emission
- Ps = Cooling sensible emission
- Qw = Water flow
- Dp(c) = Water pressure drop
- Vdc = Inverter Power
- Qv = Air flow

Cooling emission of 3 row coil

Entering air temperature: 25°C – R.H.: 50%

MODEL ECM	Vdc	WT: 7/12 °C					WT: 8/13 °C				WT: 10/15 °C				WT: 12/17 °C			
		Qv m³/h	Pc kW	Ps kW	Qw l/h	Dp(c) kPa	Pc kW	Ps kW	Qw l/h	Dp(c) kPa	Pc kW	Ps kW	Qw l/h	Dp(c) kPa	Pc kW	Ps kW	Qw l/h	Dp(c) kPa
SEC 2.3	10	330	1,33	1,12	232	5,0	1,13	1,04	198	3,8	0,90	0,90	159	2,5	0,74	0,74	131	1,8
	7,5	270	1,15	0,96	200	3,9	0,99	0,89	172	3,0	0,77	0,78	135	1,9	0,63	0,63	111	1,3
	5	220	0,99	0,80	171	3,0	0,85	0,75	147	2,3	0,66	0,66	115	1,4	0,54	0,54	94	1,0
	3	170	0,81	0,65	141	2,1	0,70	0,60	122	1,6	0,53	0,53	93	1,0	0,44	0,44	77	0,7
	1	120	0,62	0,48	108	1,3	0,53	0,45	93	1,0	0,39	0,39	69	0,6	0,32	0,32	57	0,4
SEC 4.3	10	515	2,49	1,99	432	21,6	2,15	1,85	375	16,7	1,63	1,63	284	10,1	1,34	1,34	235	7,1
	7,5	430	2,17	1,71	376	16,9	1,88	1,59	327	13,1	1,40	1,40	244	7,7	1,16	1,16	202	5,5
	5	350	1,85	1,44	320	12,7	1,61	1,34	278	9,9	1,18	1,18	205	5,7	0,97	0,97	170	4,0
	3	280	1,52	1,17	264	9,0	1,33	1,09	230	7,1	0,97	0,97	168	4,0	0,80	0,80	139	2,8
	1	210	1,20	0,91	207	5,9	1,05	0,84	181	4,6	0,75	0,74	130	2,5	0,62	0,62	108	1,8
SEC 6.3	10	735	3,34	2,71	579	14,1	2,88	2,53	501	10,8	2,22	2,22	387	6,8	1,82	1,82	319	4,8
	7,5	610	2,90	2,33	503	11,0	2,51	2,17	436	8,5	1,90	1,91	331	5,2	1,57	1,57	274	3,6
	5	495	2,47	1,96	428	8,3	2,14	1,82	371	6,4	1,60	1,60	277	3,8	1,32	1,32	229	2,7
	3	395	2,07	1,61	357	6,0	1,80	1,50	310	4,7	1,33	1,33	230	2,7	1,10	1,10	190	1,9
	1	305	1,67	1,28	288	4,1	1,45	1,19	251	3,2	1,06	1,05	183	1,8	0,87	0,87	151	1,3
SEC 7.3	10	890	4,18	3,35	726	24,4	3,63	3,12	631	18,9	2,74	2,74	479	11,5	2,26	2,26	396	8,1
	7,5	755	3,69	2,93	640	19,6	3,21	2,73	557	15,2	2,40	2,40	417	9,0	1,98	1,98	345	6,4
	5	610	3,12	2,44	541	14,5	2,72	2,27	471	11,3	2,00	2,00	347	6,5	1,65	1,65	287	4,6
	3	500	2,66	2,06	460	10,9	2,32	1,92	401	8,5	1,69	1,70	293	4,9	1,40	1,40	243	3,4
	1	400	2,21	1,69	382	7,9	1,93	1,57	334	6,2	1,33	1,39	230	3,4	1,15	1,15	200	2,4
SEC 9.3	10	1395	5,25	4,48	920	19,5	4,49	4,18	789	14,9	3,63	3,63	642	10,4	2,97	2,97	528	7,4
	7,5	1175	4,70	3,95	820	15,9	4,04	3,68	706	12,2	3,21	3,22	563	8,2	2,63	2,63	464	5,8
	5	945	4,05	3,33	703	12,2	3,49	3,11	607	9,4	2,72	2,72	474	6,1	2,23	2,23	391	4,3
	3	785	3,56	2,89	616	9,6	3,07	2,69	532	7,5	2,36	2,36	409	4,7	1,94	1,94	337	3,2
	1	605	2,91	2,32	503	6,8	2,52	2,16	436	5,2	1,91	1,90	331	3,1	1,57	1,57	273	2,1

Correction factors for different R.H.

R.H.	WT:	7/12°C	8/13°C	10/15°C	12/17°C
48%	Pc	0,95	0,94	1,00	1,00
	Ps	1,00	1,00	1,00	1,00
46%	Pc	0,90	0,88	1,00	1,00
	Ps	1,00	1,00	1,00	1,00

LEGEND

- WT = Water temperature
- Pc = Cooling total emission
- Ps = Cooling sensible emission
- Qw = Water flow
- Dp(c) = Water pressure drop
- Vdc = Inverter Power
- Qv = Air flow

Cooling emission of 4 row coil

Entering air temperature: 27°C – R.H.: 50%

MODEL ECM	Vdc	WT: 7/12 °C					WT: 8/13 °C					WT: 10/15 °C					WT: 12/17 °C				
		Qv	Pc	Ps	Qw	Dp(c)	Pc	Ps	Qw	Dp(c)	Pc	Ps	Qw	Dp(c)	Pc	Ps	Qw	Dp(c)			
		m³/h	kW	kW	l/h	kPa	kW	kW	l/h	kPa	kW	kW	l/h	kPa	kW	kW	l/h	kPa			
SEC 2.4	10	325	2,00	1,42	348	16,9	1,79	1,33	312	13,8	1,35	1,16	235	8,3	1,02	1,02	179	5,0			
	7,5	260	1,69	1,18	294	12,5	1,52	1,11	264	10,3	1,15	0,97	200	6,2	0,85	0,85	149	3,7			
	5	210	1,42	0,98	245	9,1	1,27	0,92	220	7,5	0,96	0,80	168	4,6	0,71	0,71	123	2,6			
	3	160	1,14	0,78	197	6,2	1,02	0,73	178	5,1	0,78	0,64	136	3,1	0,56	0,56	98	1,8			
	1	115	0,84	0,57	145	3,6	0,75	0,53	131	3,0	0,58	0,46	100	1,9	0,41	0,41	71	1,0			
SEC 4.4	10	505	3,42	2,38	592	18,5	3,06	2,23	531	15,2	2,32	1,94	403	9,2	1,71	1,71	299	5,4			
	7,5	415	2,92	2,02	506	14,0	2,63	1,89	454	11,5	2,00	1,64	346	7,0	1,45	1,45	253	4,0			
	5	340	2,44	1,67	421	10,1	2,19	1,56	379	8,4	1,67	1,36	290	5,1	1,20	1,20	208	2,8			
	3	265	1,97	1,34	340	7,0	1,77	1,25	307	5,8	1,36	1,09	235	3,6	0,96	0,96	167	1,9			
	1	200	1,54	1,04	266	4,5	1,39	0,97	240	3,7	1,07	0,84	185	2,3	0,75	0,75	129	1,2			
SEC 6.4	10	720	4,85	3,36	839	37,4	4,36	3,16	755	30,9	3,32	2,75	577	19,0	2,43	2,43	423	10,8			
	7,5	590	4,12	2,84	713	28,1	3,71	2,67	642	23,2	2,84	2,32	492	14,3	2,05	2,05	356	8,0			
	5	475	3,42	2,33	590	20,2	3,08	2,19	533	16,7	2,37	1,91	409	10,4	1,69	1,69	293	5,7			
	3	375	2,79	1,89	481	14,1	2,52	1,78	434	11,7	1,94	1,54	335	7,3	1,36	1,36	236	3,9			
	1	290	2,20	1,48	379	9,2	1,99	1,39	343	7,7	1,54	1,21	265	4,8	1,07	1,07	184	2,5			
SEC 7.4	10	875	5,70	3,98	987	29,1	5,12	3,74	888	24,0	3,90	3,26	677	14,7	2,87	2,87	501	8,5			
	7,5	735	4,95	3,43	857	22,7	4,46	3,23	771	18,7	3,40	2,81	590	11,5	2,47	2,47	431	6,5			
	5	585	4,11	2,82	710	16,3	3,70	2,65	639	13,5	2,83	2,30	491	8,3	2,04	2,04	354	4,6			
	3	475	3,43	2,34	593	11,9	3,10	2,20	535	9,8	2,38	1,91	412	6,1	1,69	1,69	293	3,3			
	1	380	2,81	1,90	484	8,3	2,53	1,79	437	6,9	1,95	1,55	337	4,3	1,37	1,37	237	2,3			
SEC 9.4	10	1365	7,60	5,50	1324	23,7	6,77	5,17	1182	19,3	5,04	4,51	883	11,4	3,94	3,94	695	7,4			
	7,5	1145	6,68	4,79	1160	18,8	5,96	4,50	1037	15,3	4,46	3,91	778	9,1	3,43	3,43	602	5,7			
	5	910	5,61	3,97	972	13,8	5,02	3,73	871	11,3	3,77	3,24	656	6,8	2,85	2,85	497	4,1			
	3	755	4,84	3,40	837	10,6	4,34	3,19	750	8,7	3,27	2,77	567	5,2	2,45	2,45	426	3,1			
	1	575	3,87	2,69	669	7,1	3,48	2,52	601	5,9	2,64	2,19	456	3,6	1,93	1,93	335	2,0			

Correction factors for different R.H.

R.H.	WT:	7/12°C	8/13°C	10/15°C	12/17°C
48%	Pc	0,95	0,94	1,00	1,00
	Ps	1,00	1,00	1,00	1,00
46%	Pc	0,90	0,88	1,00	1,00
	Ps	1,00	1,00	1,00	1,00

LEGEND

- WT = Water temperature
- Pc = Cooling total emission
- Ps = Cooling sensible emission
- Qw = Water flow
- Dp(c) = Water pressure drop
- Vdc = Inverter Power
- Qv = Air flow

Cooling emission of 4 row coil

Entering air temperature: 26°C – R.H.: 50%

MODEL ECM	Vdc	WT: 7/12 °C					WT: 8/13 °C				WT: 10/15 °C				WT: 12/17 °C			
		Qv m³/h	Pc kW	Ps kW	Qw l/h	Dp(c) kPa	Pc kW	Ps kW	Qw l/h	Dp(c) kPa	Pc kW	Ps kW	Qw l/h	Dp(c) kPa	Pc kW	Ps kW	Qw l/h	Dp(c) kPa
SEC 2.4	10	325	1,78	1,33	310	13,8	1,57	1,25	273	11,0	1,12	1,07	195	6,0	0,93	0,93	163	4,3
	7,5	260	1,51	1,12	262	10,2	1,33	1,04	232	8,2	0,95	0,89	166	4,5	0,78	0,78	136	3,1
	5	210	1,26	0,92	219	7,5	1,12	0,86	194	6,0	0,81	0,74	140	3,3	0,65	0,65	113	2,3
	3	160	1,02	0,74	176	5,1	0,90	0,69	157	4,1	0,65	0,59	114	2,3	0,51	0,51	90	1,5
	1	115	0,75	0,53	130	3,0	0,66	0,50	115	2,4	0,49	0,43	85	1,4	0,37	0,37	65	0,9
SEC 4.4	10	505	3,05	2,24	528	15,1	2,69	2,09	467	12,1	1,94	1,79	338	6,8	1,57	1,57	274	4,6
	7,5	415	2,61	1,90	452	11,5	2,31	1,77	400	9,2	1,67	1,52	291	5,2	1,33	1,33	232	3,4
	5	340	2,18	1,57	376	8,3	1,93	1,47	334	6,7	1,41	1,26	244	3,8	1,10	1,10	191	2,4
	3	265	1,76	1,26	304	5,7	1,56	1,17	271	4,6	1,14	1,01	198	2,6	0,88	0,88	153	1,7
	1	200	1,38	0,98	238	3,7	1,23	0,91	212	3,0	0,90	0,78	156	1,7	0,68	0,68	119	1,1
SEC 6.4	10	720	4,33	3,17	750	30,8	3,84	2,96	666	24,7	2,79	2,55	486	14,0	2,22	2,22	388	9,3
	7,5	590	3,69	2,67	638	23,1	3,27	2,50	567	18,6	2,39	2,15	415	10,6	1,87	1,87	326	6,9
	5	475	3,06	2,20	529	16,6	2,72	2,06	470	13,4	2,00	1,77	346	7,7	1,55	1,55	268	4,9
	3	375	2,50	1,78	431	11,6	2,22	1,66	384	9,4	1,64	1,43	283	5,4	1,25	1,25	217	3,3
	1	290	1,97	1,40	340	7,6	1,76	1,30	304	6,2	1,30	1,12	225	3,6	0,98	0,98	169	2,2
SEC 7.4	10	875	5,09	3,75	883	23,9	4,51	3,51	782	19,2	3,27	3,02	569	10,8	2,63	2,63	459	7,3
	7,5	735	4,43	3,23	766	18,6	3,93	3,02	680	15,0	2,86	2,60	497	8,5	2,26	2,26	394	5,6
	5	585	3,67	2,66	635	13,4	3,26	2,48	565	10,8	2,39	2,13	414	6,2	1,87	1,87	325	4,0
	3	475	3,08	2,21	531	9,8	2,74	2,06	473	7,9	2,01	1,77	348	4,5	1,55	1,55	269	2,8
	1	380	2,51	1,79	434	6,8	2,24	1,67	387	5,6	1,65	1,44	286	3,2	1,26	1,26	217	2,0
SEC 9.4	10	1365	6,74	5,18	1177	19,3	5,92	4,85	1035	15,3	4,30	4,30	757	8,7	3,59	3,59	635	6,3
	7,5	1145	5,93	4,50	1031	15,3	5,22	4,21	908	12,1	3,67	3,62	643	6,5	3,13	3,13	549	4,9
	5	910	4,99	3,74	866	11,2	4,40	3,50	764	8,9	3,12	3,00	544	4,9	2,60	2,60	454	3,5
	3	755	4,31	3,98	745	8,6	3,80	2,99	659	6,9	2,72	2,56	472	3,8	2,24	2,24	390	2,7
	1	575	3,45	2,53	597	5,8	3,05	2,36	528	4,7	2,20	2,02	382	2,6	1,77	1,77	307	1,7

Correction factors for different R.H.

R.H.	WT:	7/12°C	8/13°C	10/15°C	12/17°C
48%	Pc	0,95	0,94	1,00	1,00
	Ps	1,00	1,00	1,00	1,00
46%	Pc	0,90	0,88	1,00	1,00
	Ps	1,00	1,00	1,00	1,00

LEGEND

- WT = Water temperature
- Pc = Cooling total emission
- Ps = Cooling sensible emission
- Qw = Water flow
- Dp(c) = Water pressure drop
- Vdc = Inverter Power
- Qv = Air flow

Cooling emission of 4 row coil

Entering air temperature: 25°C – R.H.: 50%

MODEL ECM	Vdc	WT: 7/12 °C					WT: 8/13 °C					WT: 10/15 °C					WT: 12/17 °C				
		Qv	Pc	Ps	Qw	Dp(c)	Pc	Ps	Qw	Dp(c)	Pc	Ps	Qw	Dp(c)	Pc	Ps	Qw	Dp(c)			
		m³/h	kW	kW	l/h	kPa	kW	kW	l/h	kPa	kW	kW	l/h	kPa	kW	kW	l/h	kPa			
SEC 2.4	10	325	1,57	1,25	273	11,0	1,35	1,16	236	8,5	1,02	1,02	179	5,1	0,84	0,84	148	3,6			
	7,5	260	1,33	1,04	231	8,2	1,15	0,97	200	6,3	0,85	0,85	149	3,7	0,70	0,70	123	2,6			
	5	210	1,11	0,86	193	6,0	0,97	0,80	168	4,6	0,71	0,71	124	2,7	0,59	0,59	103	1,9			
	3	160	0,90	0,69	156	4,1	0,78	0,64	136	3,2	0,56	0,56	99	1,8	0,47	0,47	82	1,3			
	1	115	0,66	0,50	115	2,4	0,58	0,46	100	1,9	0,39	0,39	68	0,9	0,34	0,34	59	0,7			
SEC 4.4	10	505	2,68	2,10	466	12,1	2,33	1,95	405	9,4	1,72	1,72	300	5,5	1,41	1,42	246	3,9			
	7,5	415	2,30	1,78	399	9,2	2,00	1,65	347	7,2	1,46	1,46	254	4,1	1,21	1,21	210	2,9			
	5	340	1,92	1,47	333	6,7	1,68	1,37	290	5,2	1,21	1,21	209	2,9	1,00	1,00	174	2,1			
	3	265	1,56	1,18	269	4,6	1,36	1,09	235	3,6	0,92	0,92	160	1,8	0,80	0,80	139	1,4			
	1	200	1,22	0,92	211	3,0	1,07	0,85	185	2,4	0,73	0,71	127	1,2	0,62	0,62	108	0,9			
SEC 6.4	10	720	3,83	2,97	664	24,8	3,33	2,77	578	19,3	2,44	2,44	424	11,1	2,01	2,01	352	7,8			
	7,5	590	3,26	2,51	565	18,6	2,84	2,33	493	14,6	2,05	2,05	357	8,1	1,70	1,70	296	5,8			
	5	475	2,71	2,06	469	13,4	2,37	1,92	410	10,5	1,69	1,69	294	5,8	1,40	1,40	244	4,1			
	3	375	2,21	1,67	382	9,4	1,94	1,55	335	7,4	1,33	1,31	230	3,8	1,13	1,14	196	2,8			
	1	290	1,75	1,31	302	6,2	1,53	1,12	265	4,9	1,06	1,03	184	2,5	0,89	0,89	154	1,8			
SEC 7.4	10	875	4,50	3,52	780	19,2	3,91	3,27	679	15,0	2,88	2,88	502	8,7	2,38	2,38	416	6,1			
	7,5	735	3,91	3,03	678	15,0	3,41	2,82	591	11,7	2,48	2,48	432	6,7	2,05	2,05	358	4,7			
	5	585	3,25	2,49	562	10,8	2,84	2,32	491	8,5	2,05	2,05	356	4,7	1,70	1,70	295	3,4			
	3	475	2,72	2,07	471	7,9	2,38	1,92	412	6,2	1,62	1,62	281	3,1	1,41	1,41	244	2,4			
	1	380	2,23	1,68	385	5,5	1,95	1,56	337	4,4	1,34	1,32	232	2,2	1,14	1,14	198	1,7			
SEC 9.4	10	1365	5,91	4,86	1033	15,3	5,08	4,52	891	11,7	3,95	3,95	696	7,5	3,23	3,23	573	5,3			
	7,5	1145	5,20	4,22	906	12,2	4,49	3,93	783	9,3	3,44	3,44	603	5,8	2,82	2,82	497	4,1			
	5	910	4,39	3,50	762	9,0	3,79	3,26	659	6,9	2,86	2,86	498	4,2	2,35	2,35	411	2,9			
	3	755	3,79	2,99	657	6,9	3,28	2,78	569	5,3	2,46	2,46	427	3,2	2,03	2,03	353	2,2			
	1	575	3,04	2,37	526	4,7	2,64	2,20	457	3,6	1,94	1,94	336	2,1	1,60	1,60	278	1,5			

Correction factors for different R.H.

R.H.	WT:	7/12°C	8/13°C	10/15°C	12/17°C
48%	Pc	0,95	0,94	1,00	1,00
	Ps	1,00	1,00	1,00	1,00
46%	Pc	0,90	0,88	1,00	1,00
	Ps	1,00	1,00	1,00	1,00

LEGEND

- WT = Water temperature
- Pc = Cooling total emission
- Ps = Cooling sensible emission
- Qw = Water flow
- Dp(c) = Water pressure drop
- Vdc = Inverter Power
- Qv = Air flow

Heating emission of 3 row coil

Entering air temperature: 20°C

MODEL ECM	Vdc	Qv m³/h	WT: 70/60 °C			WT: 60/50 °C			WT: 50/40 °C			WT: 50/45 °C			WT: 45/40 °C		
			Ph kW	Qw l/h	Dp(c) kPa	Ph kW	Qw l/h	Dp(c) kPa	Ph kW	Qw l/h	Dp(c) kPa	Ph kW	Qw l/h	Dp(c) kPa	Ph kW	Qw l/h	Dp(c) kPa
SEC 2.3	10	330	3,64	313	6,7	2,78	239	4,3	1,92	165	2,3	2,22	383	10	1,80	309	7,0
	7,5	270	3,09	265	5,0	2,36	203	3,2	1,63	140	1,7	1,89	324	7,5	1,52	262	5,2
	5	220	2,61	224	3,7	1,99	171	2,4	1,38	119	1,3	1,59	274	5,6	1,29	222	3,9
	3	170	2,10	181	2,5	1,61	138	1,6	1,12	96	0,9	1,28	221	3,8	1,04	179	2,7
	1	120	1,55	133	1,5	1,19	102	1,0	0,83	71	0,5	0,95	163	2,2	0,77	132	1,6
SEC 4.3	10	515	6,33	544	25,2	4,86	418	16,3	3,39	291	8,9	3,87	665	37,9	3,14	540	26,7
	7,5	430	5,43	467	19,2	4,17	359	12,5	2,91	250	6,8	3,32	571	28,9	2,69	463	20,4
	5	350	4,55	391	14,1	3,50	301	9,1	2,44	210	5,0	2,78	478	21,2	2,26	388	14,9
	3	280	3,70	318	9,8	2,85	245	6,4	1,99	171	3,5	2,26	389	14,7	1,84	316	10,4
	1	210	2,85	245	6,2	2,20	189	4,0	1,54	133	2,2	1,74	300	9,3	1,42	244	6,6
SEC 6.3	10	735	8,37	719	16	6,41	551	10,3	4,45	383	5,6	5,11	879	24,1	4,14	712	17
	7,5	610	7,17	616	12,2	5,50	473	7,9	3,82	329	4,3	4,38	753	18,4	3,55	610	12,9
	5	495	6,04	520	9,0	4,64	399	5,9	3,23	278	3,2	3,69	635	13,6	3,00	515	9,6
	3	395	4,97	427	6,4	3,82	328	4,2	2,66	229	2,3	3,03	522	9,6	2,46	424	6,8
	1	305	3,95	339	4,3	3,04	261	2,8	2,12	182	1,5	2,41	415	6,4	1,96	337	4,5
SEC 7.3	10	890	10,25	882	26,7	7,87	677	17,3	5,49	472	9,5	6,26	1077	40,1	5,08	874	28,3
	7,5	755	8,94	769	21	6,87	591	13,6	4,79	412	7,5	5,46	939	31,5	4,43	762	22,2
	5	610	7,50	645	15,4	5,77	496	10	4,03	347	5,5	4,58	788	23,2	3,72	640	16,4
	3	500	6,30	542	11,3	4,85	417	7,4	3,93	338	4,1	3,85	662	17	3,13	538	12,1
	1	400	5,16	444	8,0	3,98	342	5,2	2,79	240	2,9	3,15	542	12	2,56	441	8,5
SEC 9.3	10	1395	14,95	1285	22,9	11,42	982	14,7	7,90	679	8,0	9,13	1570	34,5	7,38	1270	24,2
	7,5	1175	13,06	1123	18,1	9,99	859	11,6	6,92	595	6,3	7,98	1372	27,2	6,46	1111	19,1
	5	945	10,94	941	13,2	8,38	720	8,5	5,81	500	4,6	6,68	1149	19,9	5,41	931	14
	3	785	9,40	809	10,1	7,21	620	6,5	5,00	430	3,6	5,74	988	15,3	4,66	801	10,7
	1	605	7,55	649	6,9	5,79	498	4,5	4,03	347	2,4	4,61	793	10,4	3,74	643	7,3

LEGEND

- WT = Water temperature
- Ph = Emission
- Qw = Water flow
- Dp(c) = Water pressure drop
- Vdc = Inverter Power
- Qv = Air flow

Heating emission of 4 row coil

Entering air temperature: 20°C

MODEL ECM	Vdc	WT: 70/60 °C				WT: 60/50 °C			WT: 50/40 °C			WT: 50/45 °C			WT: 45/40 °C		
		Qv	Ph	Qw	Dp(c)	Ph	Qw	Dp(c)	Ph	Qw	Dp(c)	Ph	Qw	Dp(c)	Ph	Qw	Dp(c)
		m³/h	kW	l/h	kPa	kW	l/h	kPa	kW	l/h	kPa	kW	l/h	kPa	kW	l/h	kPa
SEC 2.4	10	325	4,01	344	12,9	3,07	264	8,3	2,14	184	4,5	2,45	421	19,4	1,98	341	13,6
	7,5	260	3,33	286	9,3	2,56	220	6,0	1,78	153	3,3	2,03	350	14	1,65	284	9,9
	5	210	2,75	237	6,7	2,12	182	4,3	1,48	127	2,4	1,68	289	10	1,37	235	7,1
	3	160	2,18	187	4,4	1,68	144	2,9	1,17	101	1,6	1,33	229	6,6	1,08	186	4,7
	1	115	1,57	135	2,5	1,21	104	1,6	0,85	73	0,9	0,96	165	3,7	0,78	134	2,6
SEC 4.4	10	505	6,60	568	12,9	5,07	436	8,4	3,54	304	4,6	4,04	694	19,5	3,28	563	13,7
	7,5	415	5,57	479	9,6	4,29	369	6,2	3,00	258	3,4	3,41	586	14,5	2,77	476	10,2
	5	340	4,59	394	6,8	3,53	304	4,4	2,48	213	2,5	2,81	484	10,3	2,29	394	7,3
	3	265	3,67	316	4,6	2,83	243	3,0	1,99	171	1,7	2,24	386	6,9	1,83	314	4,9
	1	200	2,83	244	2,9	2,19	188	1,9	1,54	132	1,1	1,73	298	4,4	1,41	243	3,1
SEC 6.4	10	720	9,43	811	27,4	7,26	624	17,8	5,08	437	9,8	5,76	991	41,2	4,68	805	29,1
	7,5	590	7,90	679	20,1	6,09	523	13,1	4,27	367	7,2	4,83	830	30,2	3,93	675	21,4
	5	475	6,48	557	14,2	5,00	430	9,2	3,51	302	5,1	3,96	681	21,3	3,23	555	15,1
	3	375	5,21	448	9,6	4,02	346	6,3	2,83	243	3,5	3,19	548	14,5	2,59	446	10,3
	1	290	4,05	348	6,2	3,13	269	4,1	2,21	190	2,3	2,48	426	9,3	2,02	347	6,6
SEC 7.4	10	875	10,93	940	20,7	8,41	723	13,5	5,88	505	7,4	6,68	1149	31,2	5,43	933	22
	7,5	735	9,39	808	15,9	7,23	622	10,3	5,06	435	5,7	5,74	987	23,9	4,66	802	16,9
	5	585	7,73	664	11,3	5,95	512	7,3	4,17	359	4,1	4,72	812	16,9	3,84	660	12
	3	475	6,38	549	8,0	4,92	423	5,2	3,45	297	2,9	3,90	671	12,1	3,17	546	8,6
	1	380	5,16	444	5,5	3,98	342	3,6	2,80	241	2,0	3,15	542	8,3	2,57	442	5,9
SEC 9.4	10	1365	16,03	1379	19,8	12,27	1055	12,8	8,50	731	6,9	9,79	1685	29,8	7,93	1364	20,9
	7,5	1145	13,82	1188	15,2	10,58	910	9,8	7,35	632	5,3	8,44	1452	22,9	6,84	1176	16,1
	5	910	11,37	978	10,8	8,72	750	7,0	6,06	521	3,8	6,94	1194	16,3	5,63	969	11,4
	3	755	9,69	834	8,2	7,44	640	5,3	5,18	446	2,9	5,92	1019	12,3	4,81	826	8,7
	1	575	7,58	652	5,3	5,82	501	3,4	4,07	350	1,9	4,63	796	8,0	3,76	647	5,6

LEGEND

- WT = Water temperature
- Ph = Emission
- Qw = Water flow
- Dp(c) = Water pressure drop
- Vdc = Inverter Power
- Qv = Air flow

Heating emission of 1 row additional coil

Entering air temperature: 20°C

MODEL ECM	Vdc	WT: 80/70 °C				WT: 75/65 °C				WT: 70/60 °C				WT: 65/55 °C				WT: 60/50 °C				WT: 55/45 °C			
		Qv	Ph	Qw	Dp(c)	Ph	Qw	Dp(c)	Ph	Qw	Dp(c)	Ph	Qw	Dp(c)	Ph	Qw	Dp(c)	Ph	Qw	Dp(c)	Ph	Qw	Dp(c)		
		m³/h	kW	l/h	kPa	kW	l/h	kPa	kW	l/h	kPa	kW	l/h	kPa	kW	l/h	kPa	kW	l/h	kPa	kW	l/h	kPa		
SEC 2	10	330	2,04	176	6,3	1,84	158	5,3	1,63	140	4,3	1,43	123	3,5	1,22	105	2,7	1,018	88	2,0					
	7,5	270	1,78	153	4,9	1,60	138	4,1	1,42	122	3,4	1,24	107	2,7	1,07	92	2,1	0,888	76	1,6					
	5	220	1,54	132	3,8	1,38	119	3,2	1,23	106	2,6	1,08	93	2,1	0,92	79	1,6	0,77	66	1,2					
	3	170	1,29	111	2,8	1,16	100	2,4	1,04	89	1,9	0,91	78	1,6	0,78	67	1,2	0,65	56	0,9					
	1	120	1,02	87	1,8	0,92	79	1,5	0,81	70	1,3	0,71	61	1,0	0,61	53	0,8	0,512	44	0,6					
SEC 4	10	515	3,41	293	19,4	3,08	264	16,4	2,74	236	13,6	2,41	207	11	2,07	178	8,6	1,74	150	6,4					
	7,5	430	3,01	259	15,6	2,72	234	13,2	2,42	208	10,9	2,13	183	8,8	1,83	158	6,9	1,54	132	5,2					
	5	350	2,62	225	12,2	2,36	203	10,3	2,11	181	8,5	1,85	159	6,9	1,60	137	5,4	1,34	115	4,0					
	3	280	2,22	191	9,1	2,01	172	7,7	1,79	154	6,4	1,57	135	5,2	1,36	117	4,1	1,139	98	3,0					
	1	210	1,82	157	6,4	1,64	141	5,4	1,47	126	4,5	1,29	111	3,6	1,11	96	2,9	0,935	80	2,1					
SEC 6	10	735	4,61	396	6,4	4,14	356	5,4	3,68	317	4,5	3,22	277	3,6	2,76	238	2,8	2,303	198	2,0					
	7,5	610	4,05	348	5,1	3,64	313	4,3	3,24	278	3,6	2,83	244	2,9	2,43	209	2,2	2,029	174	1,6					
	5	495	3,50	301	4,0	3,15	271	3,3	2,80	241	2,8	2,45	211	2,2	2,11	181	1,7	1,76	151	1,3					
	3	395	3,00	258	3,0	2,70	232	2,5	2,40	206	2,1	2,10	181	1,7	1,81	155	1,3	1,509	130	1,0					
	1	305	2,50	215	2,2	2,25	194	1,9	2,00	172	1,5	1,76	151	1,2	1,51	130	1,0	1,263	109	0,7					
SEC 7	10	890	5,77	496	11,2	5,20	447	9,5	4,63	398	7,8	4,06	349	6,3	3,50	301	4,9	2,929	252	3,7					
	7,5	755	5,15	443	9,2	4,64	399	7,8	4,13	355	6,4	3,63	312	5,2	3,12	268	4,0	2,616	225	3,0					
	5	610	4,43	381	7,1	4,00	344	6,0	3,56	306	4,9	3,13	269	4,0	2,69	231	3,1	2,258	194	2,3					
	3	500	3,86	332	5,5	3,48	299	4,7	3,10	267	3,9	2,72	234	3,1	2,35	202	2,4	1,969	169	1,8					
	1	400	3,30	284	4,2	2,97	256	3,5	2,65	228	2,9	2,33	200	2,4	2,01	173	1,9	1,685	145	1,4					
SEC 9	10	1395	7,46	641	17,6	6,72	578	14,9	5,98	514	12,3	5,24	451	9,9	4,51	388	7,7	3,772	324	5,7					
	7,5	1175	6,67	574	14,5	6,01	517	12,2	5,35	460	10,1	4,69	404	8,2	4,04	347	6,4	3,379	291	4,7					
	5	945	5,75	495	11,2	5,18	446	9,4	4,62	397	7,8	4,05	348	6,3	3,48	300	4,9	2,919	251	3,7					
	3	785	5,08	437	9,0	4,58	394	7,6	4,08	351	6,3	3,58	308	5,1	3,08	265	3,9	2,582	222	2,9					
	1	605	4,23	364	6,5	3,82	328	5,5	3,40	292	4,6	2,99	257	3,7	2,57	221	2,9	2,158	186	2,1					

LEGEND

- WT = Water temperature
- Ph = Emission
- Qw = Water flow
- Dp(c) = Water pressure drop
- Vdc = Inverter Power
- Qv = Air flow

Heating emission of 2 row additional coil

Entering air temperature: 20°C

MODEL ECM	Vdc	WT: 65/55 °C			WT: 60/50 °C			WT: 55/45 °C			WT: 50/40 °C			WT: 45/40 °C			WT: 45/35 °C			
		Qv	Ph	Qw	Dp(c)	Ph	Qw	Dp(c)	Ph	Qw	Dp(c)	Ph	Qw	Dp(c)	Ph	Qw	Dp(c)	Ph	Qw	Dp(c)
		m³/h	kW	l/h	kPa	kW	l/h	kPa	kW	l/h	kPa	kW	l/h	kPa	kW	l/h	kPa	kW	l/h	kPa
SEC 2	10	330	2,48	214	16,7	2,15	184	13,1	1,81	155	9,9	1,47	126	7,0	1,39	239	21,6	1,13	97	4,5
	7,5	270	2,13	183	12,7	1,84	158	10	1,55	133	7,5	1,26	109	5,3	1,19	205	16,5	0,97	84	3,4
	5	220	1,81	155	9,6	1,56	134	7,5	1,32	113	5,7	1,07	92	4,0	1,01	174	12,4	0,83	71	2,6
	3	170	1,49	128	6,8	1,29	111	5,3	1,10	94	4,1	0,89	77	2,9	0,84	144	8,9	0,69	59	1,9
	1	120	1,13	97	4,2	0,98	84	3,3	0,83	71	2,5	0,68	58	1,8	0,63	109	5,4	0,52	45	1,2
SEC 4	10	515	3,90	335	7,6	3,36	289	5,9	2,82	243	4,4	2,29	197	3,1	2,18	375	9,8	1,76	151	2,0
	7,5	430	3,40	292	5,9	2,93	252	4,7	2,47	212	3,5	2,00	172	2,5	1,90	327	7,7	1,54	132	1,6
	5	350	2,90	249	4,5	2,50	215	3,5	2,11	181	2,6	1,71	147	1,9	1,62	279	5,8	1,32	113	1,2
	3	280	2,43	209	3,3	2,10	181	2,6	1,77	152	1,9	1,44	124	1,4	1,36	234	4,3	1,11	95	0,9
	1	210	1,94	166	2,2	1,67	144	1,7	1,41	121	1,3	1,15	99	0,9	1,08	186	2,8	0,89	76	0,6
SEC 6	10	735	5,63	484	17,8	4,87	419	14	4,11	353	10,5	3,35	288	7,5	3,15	542	23	2,59	223	4,9
	7,5	610	4,88	419	13,8	4,22	363	10,9	3,56	306	8,2	2,91	250	5,8	2,73	470	17,9	2,25	194	3,8
	5	495	4,14	356	10,3	3,58	308	8,1	3,03	260	6,2	2,47	213	4,4	2,32	398	13,4	1,92	165	2,9
	3	395	3,46	297	7,5	3,00	258	5,9	2,53	218	4,5	2,09	180	3,3	1,96	336	9,9	1,62	139	2,1
	1	305	2,83	243	5,3	2,45	211	4,2	2,08	178	3,2	1,70	146	2,3	1,58	272	6,9	1,32	113	1,5
SEC 7	10	890	7,01	603	31,1	6,07	522	24,5	5,14	442	18,6	4,20	361	13,3	3,93	675	40,2	3,27	281	8,7
	7,5	755	6,17	530	24,8	5,34	460	19,6	4,52	389	14,8	3,70	318	10,6	3,45	594	32,1	2,88	248	6,9
	5	610	5,20	447	18,4	4,51	388	14,5	3,82	328	11	3,13	269	7,9	2,91	501	23,8	2,44	209	5,2
	3	500	4,47	384	14,1	3,88	333	11,1	3,28	282	8,4	2,69	232	6,1	2,50	431	18,2	2,10	180	4,0
	1	400	3,72	320	10,2	3,23	277	8,1	2,74	235	6,1	2,24	193	4,4	2,08	358	13,2	1,75	151	2,9
SEC 9	10	1395	9,60	825	54	8,31	714	42,6	7,02	604	32,2	5,74	493	22,9	-	-	-	4,45	383	15
	7,5	1175	8,49	730	43,5	7,35	632	34,3	6,22	535	26	5,08	437	18,5	-	-	-	3,94	339	12,1
	5	945	7,22	621	32,7	6,25	538	25,8	5,29	455	19,5	4,33	372	14	-	-	-	3,36	289	9,1
	3	785	6,28	540	25,6	5,45	468	20,2	4,61	396	15,3	3,77	324	11	-	-	-	2,93	252	7,2
	1	605	5,12	440	17,8	4,44	381	14,1	3,76	323	10,7	3,08	265	7,7	-	-	-	2,40	206	5,0

LEGEND

- WT = Water temperature
- Ph = Emission
- Qw = Water flow
- Dp(c) = Water pressure drop
- Vdc = Inverter Power
- Qv = Air flow

**Air flow and correction factors for emission
with different available pressures**

MODEL ECM	Vdc	Qv (m³/h)									K1									K2									
		Ap (Pa)									Ap (Pa)									Ap (Pa)									
		0	5	10	15	20	25	30	35	40	0	5	10	15	20	25	30	35	40	0	5	10	15	20	25	30	35	40	
SEC 2	10	330	312	288	257	223	171	88	-	-	1,00	0,95	0,89	0,82	0,73	0,60	0,32	-	-	-	0,95	0,88	0,80	0,72	0,58	0,29	-	-	
	8,5	307	276	251	213	162	92	29	-	-	1,00	0,91	0,85	0,75	0,61	0,36	0,06	-	-	-	1,00	0,90	0,83	0,73	0,59	0,34	0,03	-	-
	7,5	270	252	219	178	103	-	-	-	-	1,00	0,94	0,84	0,72	0,46	-	-	-	-	-	1,00	0,94	0,83	0,70	0,44	-	-	-	-
	6,5	248	227	187	130	56	-	-	-	-	1,00	0,93	0,80	0,60	0,26	-	-	-	-	-	1,00	0,92	0,78	0,58	0,24	-	-	-	-
	5	220	187	126	55	-	-	-	-	-	1,00	0,88	0,65	0,30	-	-	-	-	-	-	1,00	0,86	0,63	0,27	-	-	-	-	-
	3	170	122	45	-	-	-	-	-	-	1,00	0,77	0,32	-	-	-	-	-	-	-	1,00	0,75	0,29	-	-	-	-	-	-
	2	144	82	-	-	-	-	-	-	-	1,00	0,65	-	-	-	-	-	-	-	-	1,00	0,63	-	-	-	-	-	-	-
	1	120	68	-	-	-	-	-	-	-	1,00	0,64	-	-	-	-	-	-	-	-	1,00	0,62	-	-	-	-	-	-	-
SEC 4	10	515	499	477	448	401	332	247	100	-	1,00	0,97	0,94	0,89	0,82	0,71	0,56	0,22	-	0,97	0,93	0,88	0,80	0,69	0,54	0,19	-	-	
	8,5	459	444	419	377	323	229	54	-	-	1,00	0,97	0,93	0,85	0,76	0,58	0,10	-	-	1,00	0,97	0,92	0,84	0,74	0,56	0,07	-	-	
	7,5	430	396	363	320	240	89	-	-	-	1,00	0,93	0,87	0,79	0,63	0,24	-	-	-	1,00	0,92	0,86	0,77	0,61	0,21	-	-	-	
	6,5	394	374	333	272	135	-	-	-	-	1,00	0,95	0,87	0,74	0,41	-	-	-	-	1,00	0,95	0,86	0,73	0,39	-	-	-	-	
	5	350	308	255	107	-	-	-	-	-	1,00	0,90	0,78	0,37	-	-	-	-	-	1,00	0,89	0,76	0,35	-	-	-	-	-	
	3	280	227	99	-	-	-	-	-	-	1,00	0,84	0,43	-	-	-	-	-	-	1,00	0,83	0,41	-	-	-	-	-	-	
	2	233	170	-	-	-	-	-	-	-	1,00	0,78	-	-	-	-	-	-	-	1,00	0,76	-	-	-	-	-	-	-	
	1	210	126	-	-	-	-	-	-	-	1,00	0,67	-	-	-	-	-	-	-	1,00	0,65	-	-	-	-	-	-	-	
SEC 6	10	735	696	673	622	558	431	286	168	-	1,00	0,95	0,93	0,87	0,80	0,66	0,47	0,27	-	0,95	0,92	0,86	0,78	0,64	0,45	0,24	-	-	
	8,5	650	628	583	525	421	269	110	-	-	1,00	0,97	0,91	0,84	0,71	0,49	0,18	-	-	1,00	0,97	0,90	0,82	0,69	0,47	0,15	-	-	
	7,5	610	564	528	437	284	129	-	-	-	1,00	0,94	0,89	0,77	0,55	0,25	-	-	-	1,00	0,93	0,87	0,75	0,53	0,22	-	-	-	
	6,5	558	510	457	340	189	-	-	-	-	1,00	0,93	0,85	0,68	0,41	-	-	-	-	1,00	0,92	0,83	0,66	0,39	-	-	-	-	
	5	495	432	352	154	-	-	-	-	-	1,00	0,89	0,76	0,38	-	-	-	-	-	1,00	0,88	0,74	0,36	-	-	-	-	-	
	3	395	319	151	82	-	-	-	-	-	1,00	0,84	0,46	0,24	-	-	-	-	-	1,00	0,82	0,44	0,21	-	-	-	-	-	
	2	351	221	-	-	-	-	-	-	-	1,00	0,70	-	-	-	-	-	-	-	1,00	0,68	-	-	-	-	-	-	-	
	1	305	177	-	-	-	-	-	-	-	1,00	0,65	-	-	-	-	-	-	-	1,00	0,63	-	-	-	-	-	-	-	
SEC 7	10	890	846	815	756	699	590	486	341	191	1,00	0,96	0,93	0,87	0,82	0,72	0,62	0,46	0,25	0,95	0,92	0,86	0,81	0,70	0,60	0,44	0,22		
	8,5	805	756	703	652	560	437	279	114	-	1,00	0,95	0,89	0,84	0,75	0,62	0,42	0,14	-	1,00	0,94	0,88	0,83	0,73	0,60	0,40	0,11	-	
	7,5	755	696	637	558	459	300	140	-	-	1,00	0,93	0,87	0,79	0,68	0,48	0,21	-	-	1,00	0,93	0,86	0,77	0,66	0,46	0,18	-	-	
	6,5	703	637	560	449	336	175	-	-	-	1,00	0,92	0,83	0,70	0,56	0,30	-	-	-	1,00	0,91	0,82	0,68	0,54	0,27	-	-	-	
	5	610	532	443	313	133	-	-	-	-	1,00	0,89	0,78	0,59	0,26	-	-	-	-	1,00	0,88	0,76	0,57	0,23	-	-	-	-	
	3	500	398	255	83	-	-	-	-	-	1,00	0,83	0,59	0,18	-	-	-	-	-	1,00	0,81	0,57	0,15	-	-	-	-	-	
	2	452	348	178	-	-	-	-	-	-	1,00	0,81	0,47	-	-	-	-	-	-	1,00	0,79	0,45	-	-	-	-	-	-	
	1	400	279	-	-	-	-	-	-	-	1,00	0,75	-	-	-	-	-	-	-	1,00	0,73	-	-	-	-	-	-	-	
SEC 9	10	1395	1310	1225	1180	1125	1060	1000	930	860	1,00	0,95	0,90	0,87	0,84	0,80	0,77	0,73	0,68	0,94	0,89	0,86	0,82	0,78	0,75	0,71	0,66		
	8,5	1265	1175	1080	1020	960	880	800	720	640	1,00	0,94	0,88	0,84	0,80	0,75	0,70	0,64	0,59	1,00	0,93	0,86	0,82	0,78	0,73	0,68	0,62	0,57	
	7,5	1175	1075	970	910	840	750	650	545	450	1,00	0,93	0,85	0,81	0,77	0,70	0,63	0,54	0,46	1,00	0,92	0,84	0,80	0,75	0,68	0,61	0,52	0,44	
	6,5	1085	980	865	790	700	605	500	350	200	1,00	0,92	0,83	0,78	0,71	0,63	0,54	0,39	0,21	1,00	0,91	0,82	0,76	0,69	0,61	0,52	0,37	0,18	
	5	945	835	680	580	460	315	160	-	-	1,00	0,90	0,77	0,68	0,57	0,40	0,18	-	-	1,00	0,89	0,75	0,66	0,55	0,38	0,15	-	-	
	3	785	620	400	230	50	-	-	-	-	1,00	0,83	0,59	0,35	-	-	-	-	-	1,00	0,81	0,57	0,33	-	-	-	-	-	
	2	700	500	200	-	-	-	-	-	-	1,00	0,77	0,34	-	-	-	-	-	-	1,00	0,75	0,32	-	-	-	-	-	-	
	1	605	390	-	-	-	-	-	-	-	1,00	0,71	-	-	-	-	-	-	-	1,00	0,69	-	-	-	-	-	-	-	

LEGEND

- Qv = Air flow
- K1 = Correction factors for Total cooling emission
- K2 = Correction factors for Sensible cooling emission and Heating emission
- Ap = Available pressure
- Vdc = Inverter Power

Water pressure drop

3 row coil

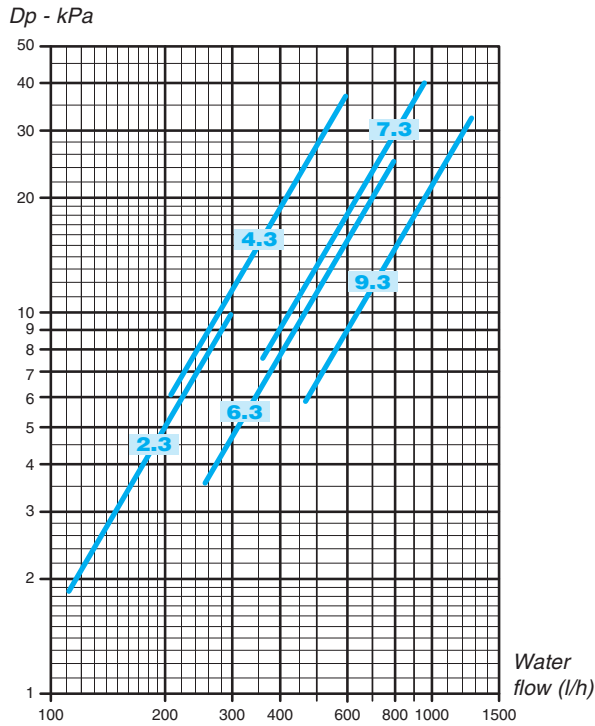

4 row coil

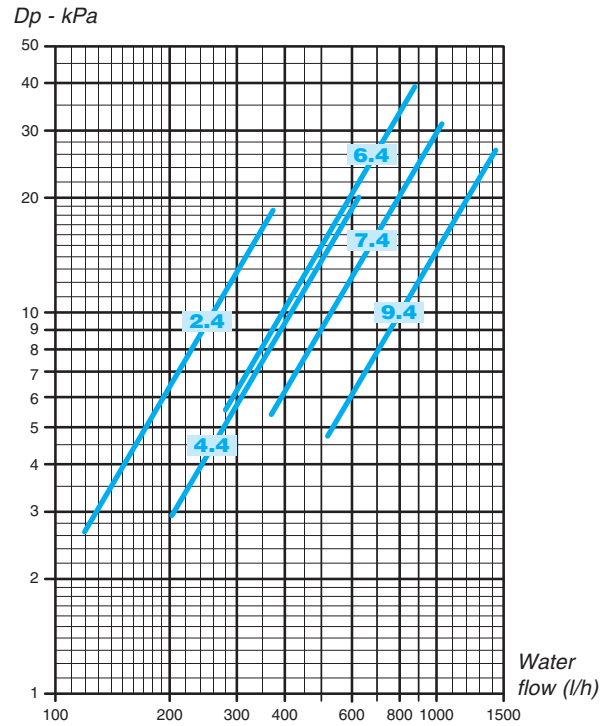

The water pressure drop figures refer to a mean water temperature of **10°C**; for different temperatures, multiply the pressure drop figures by the correction factors **K**.

°C	20	30	40	50	60	70	80
K	0,94	0,90	0,86	0,82	0,78	0,74	0,70

1 row additional coil

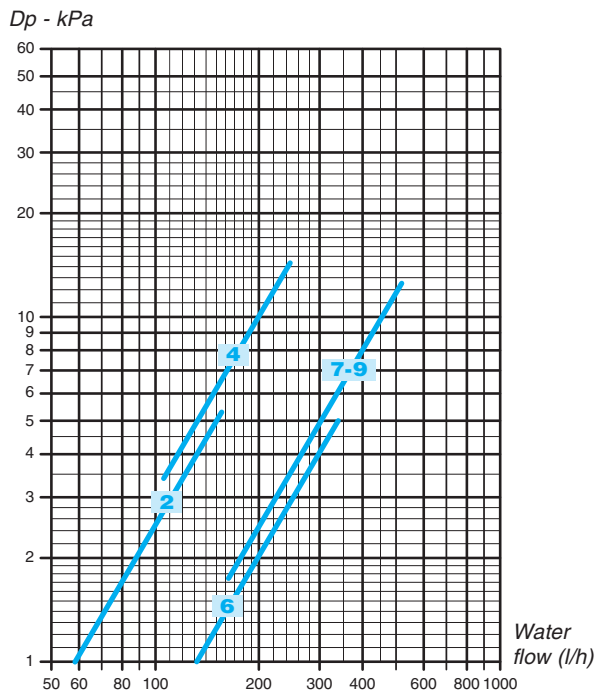

2 row additional coil

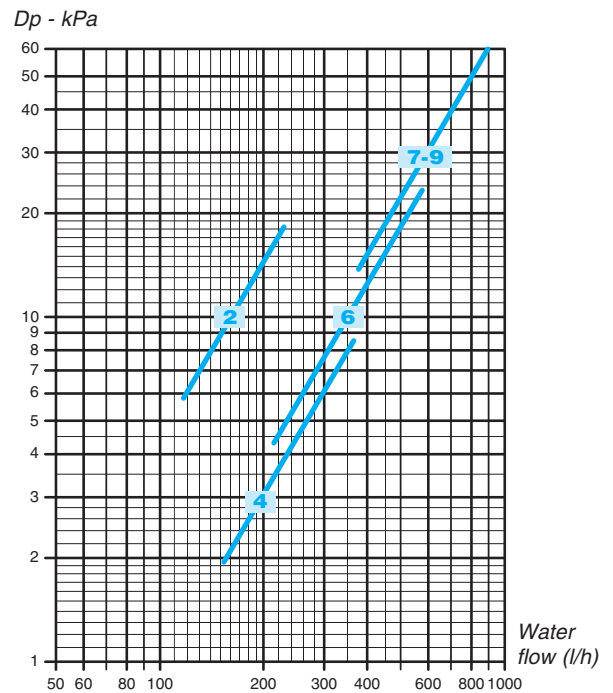

The water pressure drop figures refer to a mean water temperature of **60°C**; for different temperatures, multiply the pressure drop figures by the correction factors **K**.

°C	40	50	70	80
K	1,12	1,06	0,94	0,88

Construction features

Casing

Made of 1 mm galvanized steel insulated with 3 mm polyolefin (PO) foam (class M1).

Filter

Polypropylene cellular fabric regenerating filter.
The filter frame of galvanized steel is inserted into special plastic sliding guides fastened to the internal structure for easy insertion and removal of the filter.

Fan assembly

The fans have aluminium or plastic blades directly keyed on the motor with double aspiration and they are dynamically and statically balanced during manufacture in order to have an extremely quiet operation.

Electronic motor

Three phase permanent magnet brushless electronic motor that is controlled with reconstructed current according to a BLAC sinusoidal wave. The inverter board that controls the motor operation is powered by 230 Volt, single-phase and, with a switching system, it generates a three-phase frequency modulated, wave form power supply. The electric power supply required for the machine is therefore single-phase with voltage of 230-240V and frequency of 50-60Hz.

Coil

It is manufactured from drawn copper tube and the aluminium fins are mechanically bonded onto the tube by an expansion process.
The coil has two 1/2 inch BSP internal connections and 1/8 inch BSP air vent and drain.

The coil is not suitable for use in corrosive atmosphere or in environments where aluminium may be subject to corrosion.
The connections are on the left hand side looking from the air outlet of the unit (see picture).

On request or on site the connections can be moved to the other side.

Condensate collection tray

Made of plastic (ABS UL94 HB) with a "L"-shaped plastic fitted on the inner casing; the tray is insulated with 3 mm polyolefin (PO) foam (class M1).
The outside diameter of the condensate discharge pipe is 15mm.

Accessories and Controls

See pages 44 and 62.

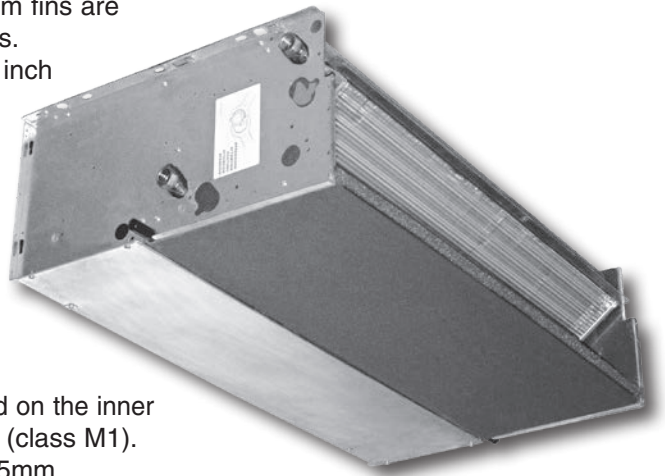
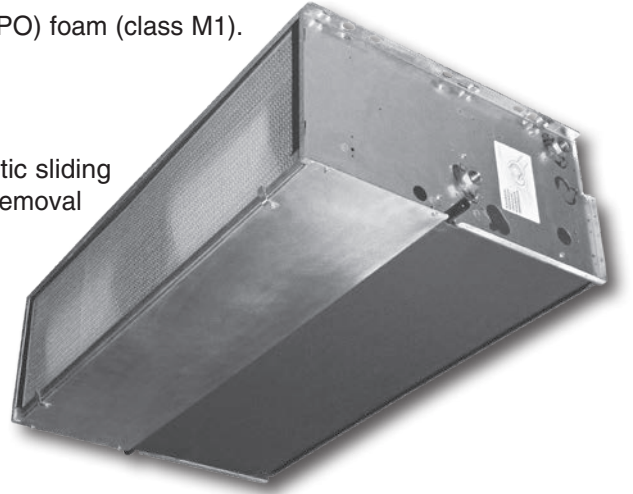

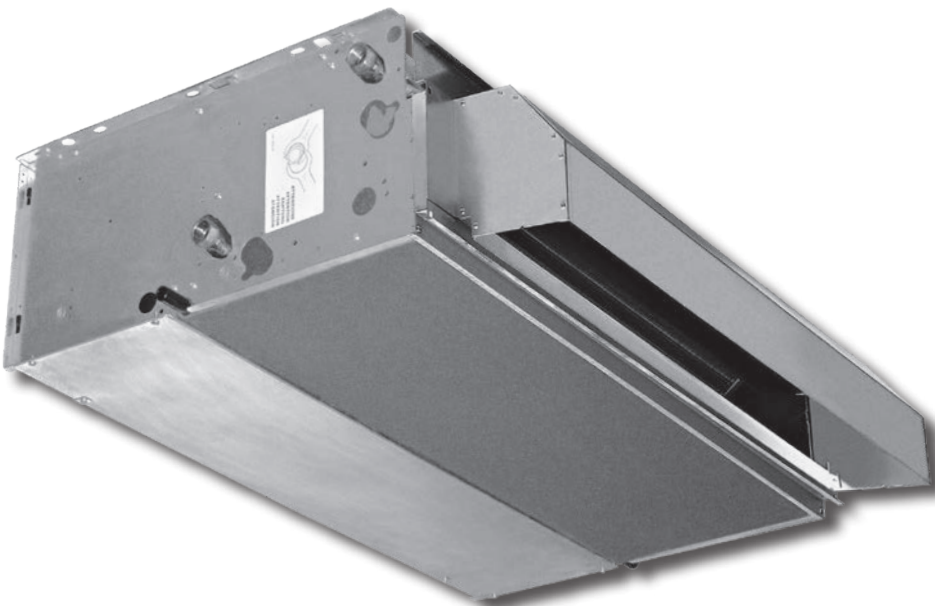
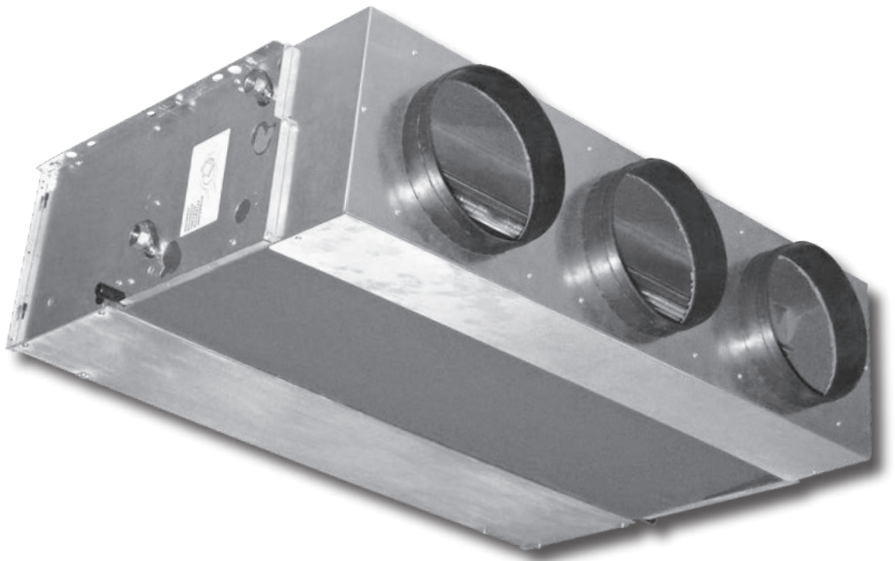
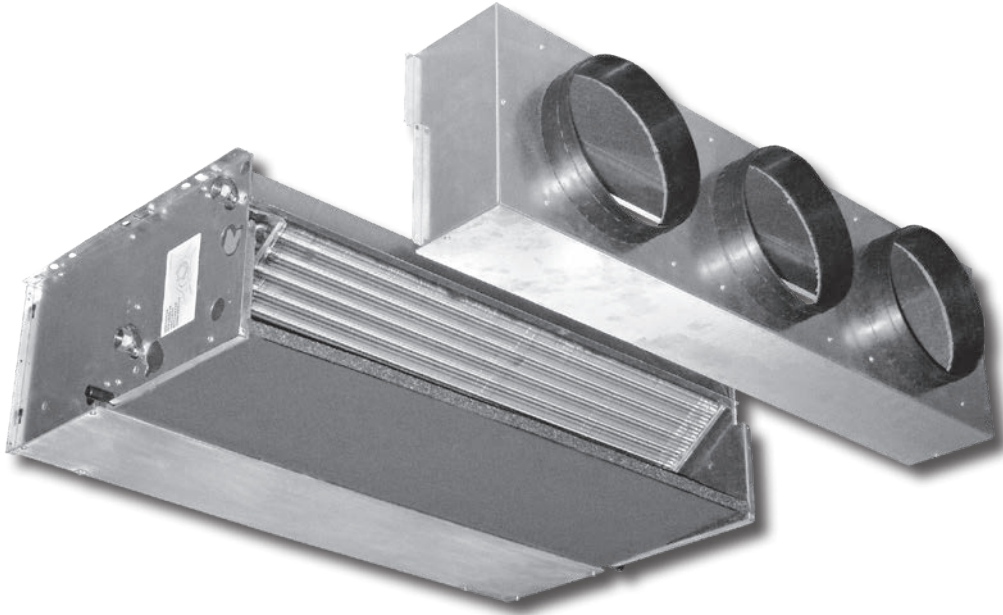

Dimension, Weight, Water content

Vertical Installation

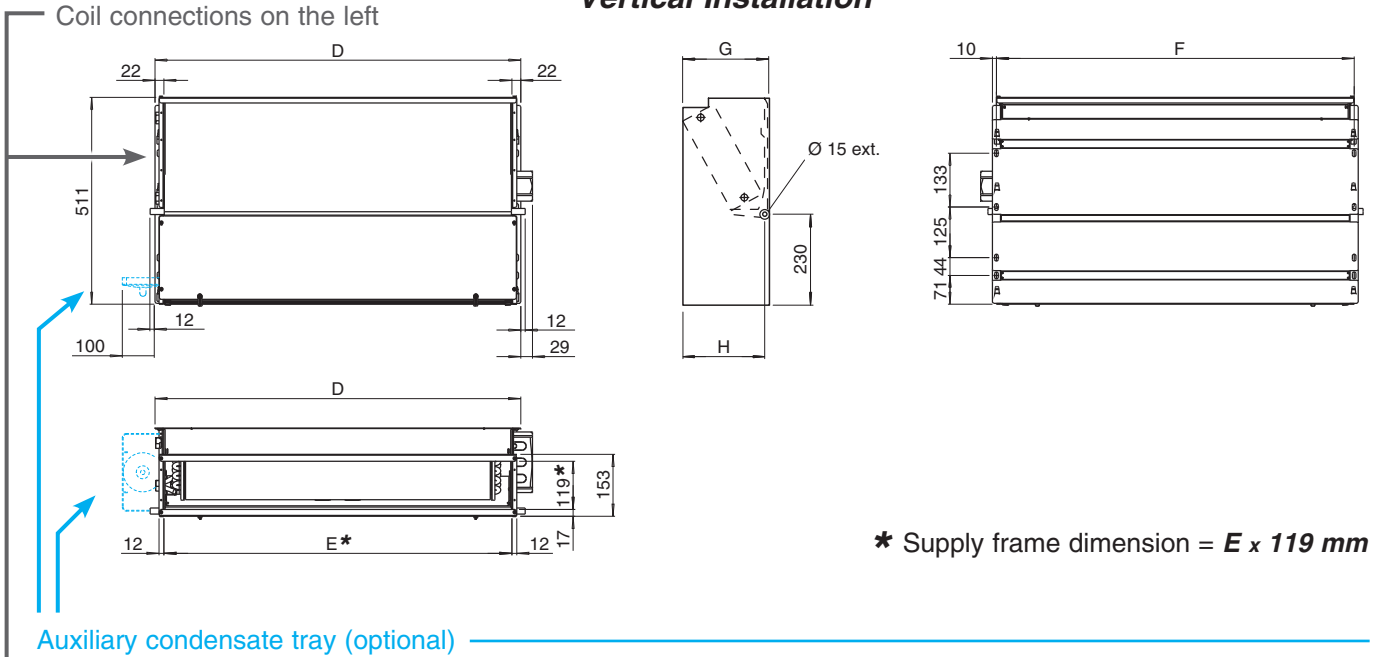

Horizontal Installation

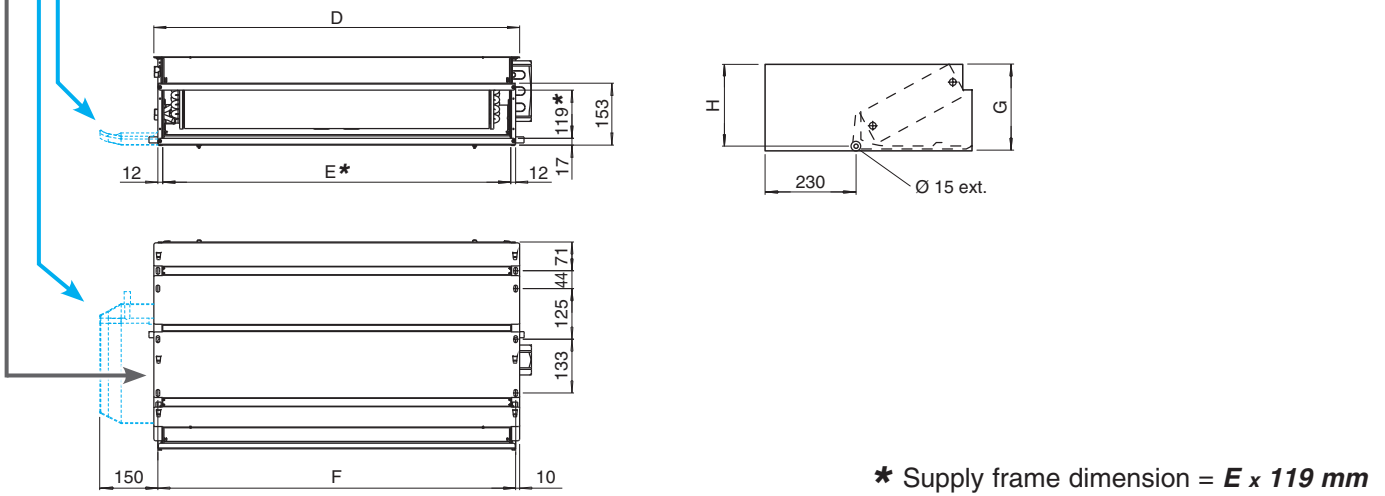

COIL CONNECTIONS

3 or 4 row coils

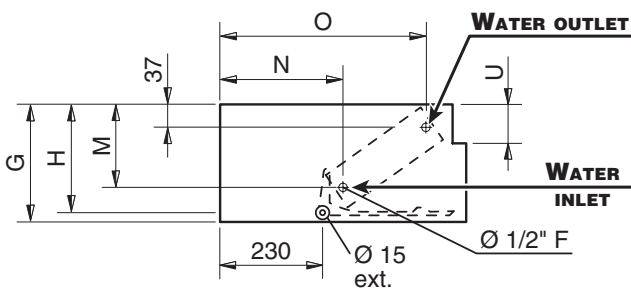

Heating additional coil (1 or 2 rows)

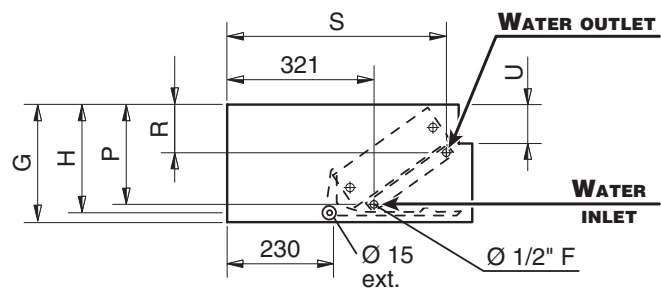

Dimension, Weight, Water content

PACKAGING

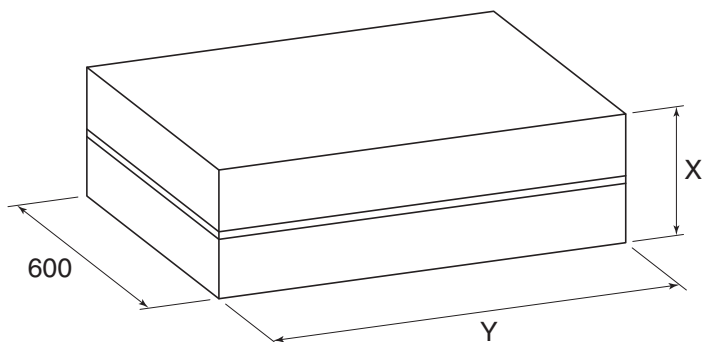

Dimension (mm)

MODEL	1	2	3
<i>D</i>	689	904	1119
<i>E</i>	645	860	1075
<i>F</i>	669	884	1099
<i>G</i>	218	248	248
<i>H</i>	205	235	235
<i>M</i>	145	170	170
<i>N</i>	260	270	270
<i>O</i>	460	450	450
<i>P</i>	185	210	210
<i>R</i>	105	110	110
<i>S</i>	475	465	465
<i>U</i>	65	95	95
<i>X</i>	260	290	290
<i>Y</i>	820	1035	1250

Weight (kg)

		<i>Weight with packaging</i>			<i>Weight without packaging</i>		
MODEL		1	2	3	1	2	3
Rows	<i>3</i>	19,1	26,1	30,4	17,3	23,5	27,3
	<i>3+1</i>	20,3	27,6	32,2	18,5	25,0	29,1
	<i>3+2</i>	21,0	28,5	33,3	19,2	25,9	30,2
	<i>4</i>	20,1	27,4	31,9	18,3	24,8	28,8
	<i>4+1</i>	21,3	28,9	33,7	19,5	26,3	30,6

Water content (litres)

MODEL		1	2	3
Rows	<i>3</i>	0,9	1,6	1,9
	<i>4</i>	1,3	2,2	2,8
	<i>+1</i>	0,3	0,5	0,6
	<i>+2</i>	0,6	1,0	1,2

Technical features

HP-ECM UNITS WITH 3 AND 4 ROW COIL

2 pipe units.

The following standard rating conditions are used:

COOLING

Entering air temperature +27°C d.b. +19°C w.b.
Water temperature +7°C E.W.T. +12°C L.W.T.

HEATING

Entering air temperature +20°C
Water temperature +45°C E.W.T. +40°C L.W.T.

MODEL		HP-ECM 13			HP-ECM 23			HP-ECM 33		
Speed		MIN	MED	MAX	MIN	MED	MAX	MIN	MED	MAX
Inverter power		5	7	9	4	6	8	4,5	6,5	8,5
Air flow	m ³ /h	240	280	325	420	485	560	720	820	950
Available pressure	Pa	35	50	65	35	50	65	35	50	65
Cooling total emission	kW	1,53	1,73	1,94	2,63	2,94	3,27	4,16	4,57	5,06
Cooling sensible emission	kW	1,14	1,30	1,47	1,99	2,24	2,51	3,22	3,57	4,00
Heating	kW	1,59	1,82	2,07	2,71	3,04	3,42	4,48	4,99	5,62
Dp Cooling	kPa	8,9	11,1	13,7	9	11	13,4	10,5	12,4	15
Dp Heating	kPa	7,8	9,9	12,4	7,8	9,5	11,8	9,8	11,8	14,6
Fan	W	24	32	43	30	44	64	50	71	102
Sound power outlet	dB(A)	45	48	52	45	49	52	50	53	56
Sound power inlet + radiated	dB(A)	52	54	58	51	55	58	56	60	63
Sound pressure outlet (*)	dB(A)	36	39	43	36	40	43	41	44	47
Sound pressure inlet + radiated (*)	dB(A)	43	45	49	42	46	49	47	51	54
Plenum code		9066363			9069222			9066368		

MODEL		HP-ECM 14			HP-ECM 24			HP-ECM 34		
Speed		MIN	MED	MAX	MIN	MED	MAX	MIN	MED	MAX
Inverter power		5	7	9	4	6	8	4,5	6,5	8,5
Air flow	m ³ /h	240	280	325	420	485	560	720	820	950
Available pressure	Pa	35	50	65	35	50	65	35	50	65
Cooling total emission	kW	1,67	1,90	2,15	2,88	3,25	3,64	4,44	4,91	5,48
Cooling sensible emission	kW	1,23	1,40	1,60	2,12	2,40	2,71	3,37	3,75	4,22
Heating	kW	1,71	1,97	2,25	2,90	3,32	3,77	4,80	5,37	6,06
Dp Cooling	kPa	5,4	6,8	8,5	15,1	18,7	23	9,1	10,9	13,3
Dp Heating	kPa	4,6	5,9	7,4	12,8	15,9	19,9	8,5	10,4	12,8
Fan	W	24	32	43	30	44	64	50	71	102
Sound power outlet	dB(A)	45	48	52	45	49	52	50	53	56
Sound power inlet + radiated	dB(A)	52	54	58	51	55	58	56	60	63
Sound pressure outlet (*)	dB(A)	36	39	43	36	40	43	41	44	47
Sound pressure inlet + radiated (*)	dB(A)	43	45	49	42	46	49	47	51	54
Plenum code		9066363			9069222			9066368		

(*) = The sound pressure levels are 9 dB(A) lower than the sound power levels and apply to the reverberant field of a 100 m³ room and a reverberation time of 0.5 sec.

Technical features

HP-ECM UNITS WITH 1 ROW ADDITIONAL COIL

4 pipe units.

The following standard rating conditions are used:

COOLING

Entering air temperature +27°C d.b. +19°C w.b.
Water temperature +7°C E.W.T. +12°C L.W.T.

HEATING

Entering air temperature +20°C
Water temperature +65°C E.W.T. +55°C L.W.T.

MODEL		HP-ECM 13+1			HP-ECM 23+1			HP-ECM 33+1		
Speed		MIN	MED	MAX	MIN	MED	MAX	MIN	MED	MAX
Inverter power		5	7	9	4	6	8	4,5	6,5	8,5
Air flow	m ³ /h	240	280	325	420	485	560	720	820	950
Available pressure	Pa	35	50	65	35	50	65	35	50	65
Cooling total emission	kW	1,53	1,73	1,94	2,63	2,94	3,27	4,16	4,57	5,06
Cooling sensible emission	kW	1,14	1,30	1,47	1,99	2,24	2,51	3,22	3,57	4,00
Heating	kW	1,44	1,60	1,78	2,29	2,53	2,79	3,48	3,80	4,20
Dp Cooling	kPa	8,9	11,1	13,7	9	11	13,4	13,2	15,6	18,8
Dp Heating	kPa	4,4	5,4	6,4	2,8	3,3	3,9	4,8	5,6	6,7
Fan	W	24	32	43	30	44	64	50	71	102
Sound power outlet	dB(A)	45	48	52	45	49	52	50	53	56
Sound power inlet + radiated	dB(A)	52	54	58	51	55	58	56	60	63
Sound pressure outlet (*)	dB(A)	36	39	43	36	40	43	41	44	47
Sound pressure inlet + radiated (*)	dB(A)	43	45	49	42	46	49	47	51	54
Plenum code		9066363			9069222			9066368		

(*) = The sound pressure levels are 9 dB(A) lower than the sound power levels and apply to the reverberant field of a 100 m³ room and a reverberation time of 0.5 sec.

Main performance and technical characteristics

2 pipe units. The following standard rating conditions are used:

COOLING

Entering air temperature +27°C d.b. +19°C w.b.
Water temperature +7°C E.W.T. +12°C L.W.T.

HEATING

Entering air temperature +20°C
Water temperature +45°C E.W.T. +40°C L.W.T.

AVAILABLE PRESSURE: 0 Pa

MODEL		HP-ECM 13					HP-ECM 23					HP-ECM 33				
Vdc		1	3	5	7,5	10	1	3	5	7,5	10	1	3	5	7,5	10
Air flow	m ³ /h	350	425	515	625	730	610	760	920	1120	1250	770	985	1180	1425	1450
Cooling total emission	kW	2,08	2,41	2,76	3,15	3,48	3,53	4,14	4,72	5,35	4,91	4,39	5,25	5,93	6,69	6,76
Cooling sensible emission	kW	1,59	1,86	2,16	2,51	2,80	2,74	3,26	3,79	4,38	4,91	3,42	4,17	4,80	5,52	5,58
Heating	kW	2,19	2,58	3,02	3,52	3,97	3,67	4,39	5,11	5,94	6,45	4,73	5,79	6,69	7,74	7,84
Dp Cooling	kPa	15,2	19,7	25,2	32,1	38,6	15	20	25	32	28	11,4	15,7	19,6	24,5	25,0
Dp Heating	kPa	13,7	18,2	24,0	31,5	39,0	13	18	24	31	36	10,8	15,4	19,8	25,6	26,2
Fan	W	18	25,5	37	56	83	24	37	59	100	132	32	49	76	122	136
Sound power	Lw dB(A)	47	53	57	62	66	47	53	58	63	66	52	57	61	65	66
Sound pressure (*)	Lp dB(A)	38	44	48	53	57	38	44	49	54	57	43	48	52	56	57

MODEL		HP-ECM 14					HP-ECM 24					HP-ECM 34				
Vdc		1	3	5	7,5	10	1	3	5	7,5	10	1	3	5	7,5	10
Air flow	m ³ /h	350	425	515	625	730	610	760	920	1120	1250	770	985	1180	1425	1450
Cooling total emission	kW	2,31	2,71	3,15	3,64	4,06	3,95	4,69	5,41	6,22	6,70	4,70	5,69	6,50	7,41	7,49
Cooling sensible emission	kW	1,73	2,05	2,41	2,82	3,19	2,96	3,56	4,16	4,86	5,28	3,59	4,41	5,09	5,90	5,97
Heating	kW	2,41	2,86	3,38	3,99	4,54	4,07	4,92	5,79	6,80	7,43	5,09	6,25	7,28	8,50	8,62
Dp Cooling	kPa	9,5	12,5	16,4	21,3	26,0	26,1	35,4	45,9	59,1	67,8	9,9	13,9	17,7	22,5	23,0
Dp Heating	kPa	8,4	11,3	15,2	20,4	25,6	22,8	31,8	42,3	56,3	65,8	9,4	13,6	17,7	23,3	23,9
Fan	W	18	25,5	37	56	83	24	37	59	100	132	32	49	76	122	136
Sound power	Lw dB(A)	47	53	57	62	66	47	53	58	63	66	52	57	61	65	66
Sound pressure (*)	Lp dB(A)	38	44	48	53	57	38	44	49	54	57	43	48	52	56	57

4 pipe units. The following standard rating conditions are used:

COOLING

Entering air temperature +27°C d.b. +19°C w.b.
Water temperature +7°C E.W.T. +12°C L.W.T.

HEATING

Entering air temperature +20°C
Water temperature +65°C E.W.T. +55°C L.W.T.

AVAILABLE PRESSURE: 0 Pa

MODEL		HP-ECM 13+1					HP-ECM 23+1					HP-ECM 33+1				
Vdc		1	3	5	7,5	10	1	3	5	7,5	10	1	3	5	7,5	10
Air flow	m ³ /h	350	425	515	625	730	610	760	920	1120	1250	770	985	1180	1425	1450
Cooling total emission	kW	2,08	2,41	2,76	3,15	3,48	3,53	4,14	4,72	5,35	4,91	4,39	5,25	5,93	6,69	6,76
Cooling sensible emission	kW	1,59	1,86	2,16	2,51	2,80	2,74	3,26	3,79	4,38	4,91	3,42	4,17	4,80	5,52	5,58
Heating	kW	1,87	2,14	2,44	2,78	3,01	2,96	3,44	3,90	4,33	4,64	3,64	4,30	4,86	5,47	5,43
Dp Cooling	kPa	15,2	19,7	25,2	32,1	38,6	15,0	20,0	25,3	32,0	27,8	14,7	20,1	25,1	31,4	32,0
Dp Heating	kPa	7,0	8,9	11,2	14,1	16,3	4,3	5,7	7,1	8,5	9,6	5,2	7,0	8,7	10,7	10,6
Fan	W	18	25,5	37	56	83	24	37	59	100	132	32	49	76	122	136
Sound power	Lw dB(A)	47	53	57	62	66	47	53	58	63	66	52	57	61	65	66
Sound pressure (*)	Lp dB(A)	38	44	48	53	57	38	44	49	54	57	43	48	52	56	57

Vdc = Inverter Power

(*) = The sound pressure levels are 9 dB(A) lower than the sound power levels and apply to the reverberant field of a 100 m³ room and a reverberation time of 0.5 sec.

Operation limits

Highest water inlet temperature..... + 85 °C

Lowest water inlet temperature..... + 5 °C

for entering water temperatures below + 5°C, contact the technical department

Highest working pressure..... 1000 kPa (10 bars)

Water flow limits for 3 row coil (l/h)

MODEL	HP-ECM 13	HP-ECM 23	HP-ECM 33
Lowest	100	150	200
Highest	750	1000	2000

Water flow limits for 4 row coil (l/h)

MODEL	HP-ECM 14	HP-ECM 24	HP-ECM 34
Lowest	150	150	300
Highest	1000	1500	2250

Water flow limits for 1 row additional coil (l/h)

MODEL	HP-ECM 1	HP-ECM 2	HP-ECM 3
Lowest	50	100	100
Highest	350	500	750

Water flow limits for 2 row additional coil (l/h)

MODEL	HP-ECM 1	HP-ECM 2	HP-ECM 3
Lowest	100	100	100
Highest	350	500	750

Motor electrical data (max. absorption)

MODEL		HP-ECM 1	HP-ECM 2	HP-ECM 3
230/1	W	83	132	136
50Hz	A	0,67	1,04	1,07

Cooling emission of 3 row coil

Entering air temperature: 27°C – R.H.: 50% – Available pressure: 0Pa

MODEL ECM	Vdc	WT: 7/12 °C					WT: 8/13 °C				WT: 10/15 °C				WT: 12/17 °C			
		Qv	Pc	Ps	Qw	Dp(c)	Pc	Ps	Qw	Dp(c)	Pc	Ps	Qw	Dp(c)	Pc	Ps	Qw	Dp(c)
		m³/h	kW	kW	l/h	kPa	kW	kW	l/h	kPa	kW	kW	l/h	kPa	kW	kW	l/h	kPa
HP 13	10	730	3,84	2,86	660	44,0	3,43	2,70	590	35,8	2,56	2,37	440	21,1	2,08	2,08	358	14,4
	7,5	625	3,46	2,54	595	36,5	3,09	2,40	531	29,8	2,32	2,10	399	17,7	1,84	1,84	316	11,7
	5	515	3,02	2,19	519	28,7	2,70	2,06	464	23,5	2,03	1,80	349	14,0	1,58	1,58	272	8,9
	3	425	2,62	1,87	451	22,4	2,35	1,76	404	18,3	1,77	1,54	304	11,0	1,35	1,35	232	6,8
	1	350	2,26	1,60	389	17,2	2,02	1,50	347	14,1	1,53	1,31	263	8,6	1,15	1,15	198	5,1
HP 23	10	1250	6,31	4,82	1085	41,3	5,62	4,55	967	33,5	4,17	4,01	717	19,5	3,50	3,50	602	14,2
	7,5	1120	5,88	4,44	1011	36,5	5,24	4,19	901	29,6	3,90	3,68	671	17,3	3,22	3,22	554	12,2
	5	920	5,15	3,82	886	28,9	4,60	3,59	791	23,5	3,43	3,15	590	13,9	2,77	2,77	476	9,4
	3	760	4,50	3,28	774	22,8	4,02	3,09	691	18,6	3,02	2,71	519	11,1	2,38	2,38	409	7,2
	1	610	3,83	2,75	659	17,1	3,43	2,59	590	14,0	2,58	2,26	444	8,4	1,99	1,99	342	5,2
HP 33	10	1450	7,44	5,67	1280	28,6	6,62	5,34	1139	23,1	4,90	4,70	843	13,4	4,10	4,10	705	9,7
	7,5	1425	7,36	5,59	1266	28,0	6,55	5,28	1127	22,7	4,84	4,63	832	13,1	4,05	4,05	697	9,5
	5	1180	6,48	4,84	1115	22,4	5,78	4,56	994	18,2	4,29	3,99	738	10,6	3,50	3,50	602	7,3
	3	985	5,71	4,20	982	18,0	5,10	3,95	877	14,6	3,80	3,46	654	8,6	3,04	3,04	523	5,7
	1	770	4,77	3,44	820	13,1	4,27	3,24	734	10,7	3,20	2,83	550	6,3	2,49	2,49	428	4,0

Cooling emission of 3 row coil

Entering air temperature: 26°C – R.H.: 50% – Available pressure: 0Pa

MODEL ECM	Vdc	WT: 7/12 °C					WT: 8/13 °C				WT: 10/15 °C				WT: 12/17 °C			
		Qv	Pc	Ps	Qw	Dp(c)	Pc	Ps	Qw	Dp(c)	Pc	Ps	Qw	Dp(c)	Pc	Ps	Qw	Dp(c)
		m³/h	kW	kW	l/h	kPa	kW	kW	l/h	kPa	kW	kW	l/h	kPa	kW	kW	l/h	kPa
HP 13	10	730	3,42	2,71	588	35,9	3,01	2,54	518	28,4	2,26	2,26	389	17,0	1,90	1,90	327	12,3
	7,5	625	3,08	2,40	530	29,8	2,71	2,25	466	23,7	2,01	2,01	346	13,7	1,68	1,68	289	10,0
	5	515	2,69	2,06	463	23,4	2,37	1,93	408	18,7	1,69	1,67	291	10,1	1,45	1,45	249	7,6
	3	425	2,33	1,77	401	18,3	2,06	1,66	354	14,6	1,47	1,43	253	8,0	1,24	1,24	213	5,8
	1	350	2,01	1,51	346	14,1	1,78	1,41	306	11,3	1,28	1,21	220	6,2	1,06	1,06	182	4,4
HP 23	10	1250	5,61	4,56	965	33,6	4,92	4,29	846	26,5	3,81	3,81	655	16,7	3,19	3,19	549	12,0
	7,5	1120	5,23	4,19	900	29,7	4,59	3,94	789	23,4	3,51	3,51	604	14,4	2,94	2,94	506	10,4
	5	920	4,58	3,60	788	23,5	4,03	3,38	693	18,6	3,01	3,01	518	11,0	2,53	2,53	435	8,0
	3	760	4,01	3,10	690	18,6	3,53	2,90	607	14,7	2,59	2,59	445	8,4	2,17	2,17	373	6,1
	1	610	3,41	2,59	587	14,0	3,01	2,43	518	11,1	2,14	2,09	368	6,1	1,82	1,82	313	4,5
HP 33	10	1450	6,61	5,35	1137	23,2	5,79	5,03	996	18,2	4,47	4,47	769	11,4	3,74	3,74	643	8,2
	7,5	1425	6,53	5,28	1123	22,7	5,73	4,96	986	17,9	4,41	4,41	759	11,1	3,69	3,69	635	8,0
	5	1180	5,76	4,57	991	18,2	5,06	4,28	870	14,4	3,81	3,81	655	8,6	3,19	3,19	549	6,2
	3	985	5,08	3,96	874	14,6	4,46	3,71	767	11,5	3,31	3,31	569	6,7	2,77	2,77	476	4,9
	1	770	4,24	3,24	729	10,6	3,74	3,04	643	8,4	2,65	2,61	456	4,5	2,27	2,27	390	3,4

NOTE: the power absorption (Watt) at page 41 must be subtracted from the total and sensible cooling emission.

Correction factors for different R.H.

R.H.	WT:	7/12°C	8/13°C	10/15°C	12/17°C
48%	Pc	0,95	0,94	1,00	1,00
	Ps	1,00	1,00	1,00	1,00
46%	Pc	0,90	0,88	1,00	1,00
	Ps	1,00	1,00	1,00	1,00

LEGEND

- WT = Water temperature
- Pc = Cooling total emission
- Ps = Cooling sensible emission
- Qw = Water flow
- Dp(c) = Water pressure drop
- Vdc = Inverter Power
- Qv = Air flow

NOTE

For air side pressure drop higher than 0Pa use correction factors at page 40 and 41.

Cooling emission of 3 row coil

Entering air temperature: 25°C – R.H.: 50% – Available pressure: 0Pa

MODEL ECM	Vdc	WT: 7/12 °C					WT: 8/13 °C					WT: 10/15 °C					WT: 12/17 °C				
		Qv m³/h	Pc kW	Ps kW	Qw l/h	Dp(c) kPa	Pc kW	Ps kW	Qw l/h	Dp(c) kPa	Pc kW	Ps kW	Qw l/h	Dp(c) kPa	Pc kW	Ps kW	Qw l/h	Dp(c) kPa			
HP 13	10	730	3,01	2,55	518	28,6	2,59	2,38	445	21,9	2,08	2,08	358	14,6	1,72	1,72	296	10,3			
	7,5	625	2,71	2,26	466	23,8	2,34	2,11	402	18,3	1,85	1,85	318	11,9	1,52	1,52	261	8,3			
	5	515	2,37	1,94	408	18,7	2,05	1,81	353	14,4	1,59	1,59	273	9,1	1,31	1,31	225	6,4			
	3	425	2,06	1,66	354	14,6	1,78	1,55	306	11,3	1,36	1,36	234	6,9	1,12	1,12	193	4,9			
	1	350	1,77	1,41	304	11,3	1,54	1,32	265	8,7	1,16	1,16	200	5,2	0,96	0,96	165	3,7			
HP 23	10	1250	4,93	4,29	848	26,7	4,23	4,02	728	20,3	3,50	3,50	602	14,4	2,88	2,88	495	10,1			
	7,5	1120	4,59	3,95	789	23,6	3,95	3,69	679	18,0	3,23	3,23	556	12,4	2,66	2,66	458	8,7			
	5	920	4,03	3,39	693	18,7	3,47	3,16	597	14,3	2,77	2,77	476	9,5	2,28	2,28	392	6,7			
	3	760	3,53	2,91	607	14,8	3,05	2,72	525	11,4	2,38	2,38	409	7,3	1,97	1,97	339	5,1			
	1	610	3,00	2,43	516	11,2	2,60	2,27	447	8,6	1,99	1,99	342	5,3	1,64	1,64	282	3,7			
HP 33	10	1450	5,79	5,03	996	18,4	4,96	4,71	853	13,9	4,10	4,10	705	9,8	3,37	3,37	580	6,9			
	7,5	1425	5,73	4,97	986	18,0	4,91	4,64	845	13,6	4,05	4,05	697	9,6	3,33	3,33	573	6,7			
	5	1180	5,05	4,29	869	14,5	4,34	4,01	746	11,0	3,51	3,51	604	7,4	2,88	2,88	495	5,2			
	3	985	4,46	3,72	767	11,6	3,84	3,47	660	8,9	3,04	3,04	523	5,8	2,50	2,50	430	4,1			
	1	770	3,73	3,04	642	8,5	3,22	2,84	554	6,5	2,49	2,49	428	4,1	2,05	2,05	353	2,9			

NOTE: the power absorption (Watt) at page 41 must be subtracted from the total and sensible cooling emission.

Correction factors for different R.H.

R.H.	WT:	7/12°C	8/13°C	10/15°C	12/17°C
48%	Pc	0,95	0,94	1,00	1,00
	Ps	1,00	1,00	1,00	1,00
46%	Pc	0,90	0,88	1,00	1,00
	Ps	1,00	1,00	1,00	1,00

LEGEND

WT = Water temperature
Pc = Cooling total emission
Ps = Cooling sensible emission
Qw = Water flow
Dp(c) = Water pressure drop
Vdc = Inverter Power
Qv = Air flow

NOTE

For air side pressure drop higher than 0Pa use correction factors at page 40 and 41.

Cooling emission of 4 row coil

Entering air temperature: 27°C – R.H.: 50% – Available pressure: 0Pa

MODEL ECM	Vdc	WT: 7/12 °C					WT: 8/13 °C				WT: 10/15 °C				WT: 12/17 °C			
		Qv	Pc	Ps	Qw	Dp(c)	Pc	Ps	Qw	Dp(c)	Pc	Ps	Qw	Dp(c)	Pc	Ps	Qw	Dp(c)
		m³/h	kW	kW	l/h	kPa	kW	kW	l/h	kPa	kW	kW	l/h	kPa	kW	kW	l/h	kPa
HP 14	10	730	4,47	3,26	769	29,7	3,99	3,07	686	24,2	2,99	2,68	514	14,4	2,36	2,36	406	9,4
	7,5	625	3,98	2,87	685	24,3	3,56	2,70	612	19,8	2,68	2,36	461	11,8	2,08	2,08	358	7,5
	5	515	3,43	2,44	590	18,7	3,07	2,29	528	15,3	2,32	2,00	399	9,2	1,77	1,77	304	5,6
	3	425	2,94	2,07	506	14,3	2,64	1,94	454	11,7	2,00	1,69	344	7,1	1,50	1,50	258	4,2
	1	350	2,51	1,75	432	10,8	2,25	1,64	387	8,9	1,71	1,43	294	5,4	1,26	1,26	217	3,1
HP 24	10	1250	7,35	5,37	1264	77,1	5,59	5,07	961	63,1	4,97	4,45	855	38,0	3,92	3,92	674	24,6
	7,5	1120	6,80	4,93	1170	67,1	6,10	4,64	1049	55,1	4,61	4,07	793	33,3	3,59	3,59	617	21,1
	5	920	5,89	4,20	1013	52,1	5,28	3,95	908	42,8	4,01	3,46	690	26,0	3,06	3,06	526	15,9
	3	760	5,08	3,59	874	40,3	4,57	3,38	786	33,1	3,48	2,95	599	20,2	2,60	2,60	447	12,0
	1	610	4,27	2,97	734	29,6	3,84	2,80	660	24,4	2,93	2,44	504	15,0	2,15	2,15	370	8,6
HP 34	10	1450	8,24	6,07	1417	26,3	7,34	5,71	1262	21,4	5,46	4,99	939	12,5	4,38	4,38	753	8,4
	7,5	1425	8,13	5,98	1398	25,8	7,25	5,63	1247	20,9	5,40	4,92	929	12,3	4,32	4,32	743	8,2
	5	1180	7,09	5,15	1219	20,2	6,33	4,84	1089	16,5	4,74	4,23	815	9,7	3,71	3,71	638	6,3
	3	985	6,19	4,44	1065	15,9	5,53	4,17	951	13,0	4,15	3,64	714	7,7	3,20	3,20	550	4,8
	1	770	5,11	3,61	879	11,3	4,57	3,39	786	9,3	3,45	2,95	593	5,6	2,62	2,62	451	3,4

Cooling emission of 4 row coil

Entering air temperature: 26°C – R.H.: 50% – Available pressure: 0Pa

MODEL ECM	Vdc	WT: 7/12 °C					WT: 8/13 °C				WT: 10/15 °C				WT: 12/17 °C			
		Qv	Pc	Ps	Qw	Dp(c)	Pc	Ps	Qw	Dp(c)	Pc	Ps	Qw	Dp(c)	Pc	Ps	Qw	Dp(c)
		m³/h	kW	kW	l/h	kPa	kW	kW	l/h	kPa	kW	kW	l/h	kPa	kW	kW	l/h	kPa
HP 14	10	730	3,97	3,07	683	24,2	3,50	2,88	602	19,2	2,57	2,57	442	11,0	2,16	2,16	372	8,0
	7,5	625	3,55	2,70	611	19,8	3,12	2,53	537	15,7	2,22	2,18	382	8,5	1,90	1,90	327	6,4
	5	515	3,06	2,30	526	15,2	2,70	2,15	464	12,2	1,93	1,85	332	6,6	1,61	1,61	277	4,8
	3	425	2,63	1,95	452	11,7	2,32	1,82	399	9,3	1,67	1,57	287	5,2	1,37	1,37	236	3,6
	1	350	2,24	1,65	385	8,8	1,98	1,54	341	7,1	1,44	1,32	248	4,0	1,16	1,16	200	2,7
HP 24	10	1250	6,56	5,08	1128	63,1	5,79	4,77	996	50,3	4,14	4,13	712	27,5	3,58	3,58	616	21,0
	7,5	1120	6,07	4,65	1044	55,0	5,37	4,37	924	44,0	3,85	3,78	662	24,1	3,28	3,28	564	18,0
	5	920	5,26	3,96	905	42,7	4,65	3,72	800	34,2	3,35	3,21	576	18,9	2,80	2,80	482	13,6
	3	760	4,54	3,38	781	33,0	4,02	3,17	691	26,5	2,92	2,74	502	14,8	2,38	2,38	409	10,3
	1	610	3,82	2,80	657	24,3	3,39	2,63	583	19,5	2,47	2,27	425	11,1	1,97	1,97	339	7,4
HP 34	10	1450	7,31	5,72	1257	21,4	6,42	5,36	1104	16,9	4,77	4,77	820	9,9	3,99	3,99	686	7,1
	7,5	1425	7,22	5,64	1242	20,9	6,34	5,29	1090	16,5	4,70	4,70	808	9,6	3,94	3,94	678	6,9
	5	1180	6,30	4,85	1084	16,4	5,54	4,54	953	13,0	4,04	4,04	695	7,4	3,39	3,39	583	5,3
	3	985	5,50	4,18	946	13,0	4,85	3,91	834	10,3	3,43	3,37	590	5,5	2,92	2,92	502	4,1
	1	770	4,55	3,40	783	9,3	4,01	3,18	690	7,4	2,86	2,73	492	4,0	2,37	2,39	407	2,9

NOTE: the power absorption (Watt) at page 41 must be subtracted from the total and sensible cooling emission.

Correction factors for different R.H.

R.H.	WT:	7/12°C	8/13°C	10/15°C	12/17°C
48%	Pc	0,95	0,94	1,00	1,00
	Ps	1,00	1,00	1,00	1,00
46%	Pc	0,90	0,88	1,00	1,00
	Ps	1,00	1,00	1,00	1,00

LEGEND

WT = Water temperature
Pc = Cooling total emission
Ps = Cooling sensible emission
Qw = Water flow
Dp(c) = Water pressure drop
Vdc = Inverter Power
Qv = Air flow

NOTE

For air side
pressure drop higher
than 0Pa use
correction factors
at page 40 and 41.

Cooling emission of 4 row coil

Entering air temperature: 25°C – R.H.: 50% – Available pressure: 0Pa

MODEL ECM	Vdc	WT: 7/12 °C					WT: 8/13 °C					WT: 10/15 °C					WT: 12/17 °C				
		Qv	Pc	Ps	Qw	Dp(c)	Pc	Ps	Qw	Dp(c)	Pc	Ps	Qw	Dp(c)	Pc	Ps	Qw	Dp(c)			
		m³/h	kW	kW	l/h	kPa	kW	kW	l/h	kPa	kW	kW	l/h	kPa	kW	kW	l/h	kPa			
HP 14	10	730	3,50	2,88	602	19,3	3,02	2,69	519	14,8	2,37	2,37	408	9,5	1,95	1,95	335	6,7			
	7,5	625	3,12	2,54	537	15,8	2,70	2,37	464	12,1	2,08	2,08	358	7,6	1,72	1,72	296	5,4			
	5	515	2,69	2,16	463	12,2	2,33	2,01	401	9,4	1,77	1,77	304	5,7	1,46	1,46	251	4,0			
	3	425	2,31	1,83	397	9,3	2,01	1,70	346	7,2	1,50	1,50	258	4,3	1,24	1,24	213	3,0			
	1	350	1,98	1,54	341	7,1	1,72	1,43	296	5,5	1,27	1,27	218	3,2	1,05	1,05	181	2,2			
HP 24	10	1250	5,79	4,78	996	50,6	5,02	4,47	863	39,1	3,93	3,93	676	25,1	3,25	3,25	559	17,7			
	7,5	1120	5,36	4,38	922	44,2	4,65	4,09	800	34,2	3,60	3,60	619	21,5	2,98	2,98	513	15,2			
	5	920	4,64	3,73	798	34,3	4,03	3,48	693	26,6	3,06	3,06	526	16,2	2,54	2,54	437	11,4			
	3	760	4,01	3,18	690	26,6	3,49	2,96	600	20,7	2,61	2,61	449	12,2	2,16	2,16	372	8,6			
	1	610	3,37	2,63	580	19,6	2,94	2,45	506	15,3	2,16	2,16	372	8,8	1,79	1,79	308	1,79			
HP 34	10	1450	6,42	5,37	1104	17,0	5,52	5,01	949	12,9	4,38	4,38	753	8,5	3,60	3,60	619	5,9			
	7,5	1425	6,34	5,29	1090	16,6	5,45	4,94	937	12,7	4,32	4,32	743	8,3	3,56	3,56	612	5,8			
	5	1180	5,53	4,55	951	13,1	4,77	4,24	820	10,0	3,71	3,71	638	6,4	3,06	3,06	526	4,5			
	3	985	4,84	3,92	832	10,3	4,18	3,65	719	7,9	3,20	3,20	550	4,9	2,64	2,64	454	3,4			
	1	770	4,00	3,19	688	7,4	3,46	2,97	595	5,7	2,62	2,62	451	3,4	2,16	2,16	372	2,4			

NOTE: the power absorption (Watt) at page 41 must be subtracted from the total and sensible cooling emission.

Correction factors for different R.H.

R.H.	WT:	7/12°C	8/13°C	10/15°C	12/17°C
48%	Pc	0,95	0,94	1,00	1,00
	Ps	1,00	1,00	1,00	1,00
46%	Pc	0,90	0,88	1,00	1,00
	Ps	1,00	1,00	1,00	1,00

LEGEND

WT = Water temperature
Pc = Cooling total emission
Ps = Cooling sensible emission
Qw = Water flow
Dp(c) = Water pressure drop
Vdc = Inverter Power
Qv = Air flow

NOTE

For air side pressure drop higher than 0Pa use correction factors at page 40 and 41.

Heating emission of 3 row coil

Entering air temperature: 20°C – Available pressure: 0Pa

MODEL ECM	Vdc	Qv m³/h	WT: 70/60 °C			WT: 60/50 °C			WT: 50/40 °C			WT: 50/45 °C			WT: 45/40 °C		
			Ph kW	Qw l/h	Dp(c) kPa	Ph kW	Qw l/h	Dp(c) kPa	Ph kW	Qw l/h	Dp(c) kPa	Ph kW	Qw l/h	Dp(c) kPa	Ph kW	Qw l/h	Dp(c) kPa
HP 13	10	730	8,03	691	36,9	6,15	529	23,8	4,26	366	12,9	4,90	843	55,5	3,97	683	39,0
	7,5	625	7,11	611	29,8	5,45	469	19,2	3,78	325	10,5	4,34	746	44,8	3,52	605	31,5
	5	515	6,09	524	22,7	4,67	402	14,7	3,25	280	8,0	3,72	640	34,1	3,02	519	24,0
	3	425	5,21	448	17,2	3,99	343	11,1	2,78	239	6,1	3,18	547	25,9	2,58	444	18,2
	1	350	4,43	381	12,9	3,40	292	8,4	2,37	204	4,6	2,70	464	19,5	2,19	377	13,7
HP 23	10	1250	13,06	1123	34,1	9,98	858	21,9	6,90	593	11,8	7,97	1371	51,2	6,45	1109	35,9
	7,5	1120	12,02	1034	29,4	9,19	790	18,9	6,36	547	10,3	7,34	1262	44,3	5,94	1022	31,1
	5	920	10,33	888	22,6	7,90	679	14,5	5,48	471	7,9	6,31	1085	33,9	5,11	879	23,8
	3	760	8,88	764	17,3	6,80	585	11,1	4,72	406	6,1	5,42	932	26,0	4,39	755	18,3
	1	610	7,42	638	12,6	5,69	489	8,1	3,95	340	4,4	4,53	779	19,0	3,67	631	13,3
HP 33	10	1450	15,89	1367	24,9	12,13	1043	16,0	8,38	721	8,6	9,70	1668	37,5	7,84	1348	26,2
	7,5	1425	15,68	1348	24,3	11,97	1029	15,6	8,27	711	8,4	9,58	1648	36,6	7,74	1331	25,6
	5	1180	13,54	1164	18,8	10,34	889	12,1	7,16	616	6,5	8,27	1422	28,3	6,69	1151	19,8
	3	985	11,71	1007	14,6	8,96	771	9,4	6,21	534	5,1	7,15	1230	21,9	5,79	996	15,4
	1	770	9,57	823	10,2	7,33	630	6,6	5,08	437	3,6	5,84	1004	15,3	4,73	814	10,8

Heating emission of 4 row coil

Entering air temperature: 20°C – Available pressure: 0Pa

MODEL ECM	Vdc	Qv m³/h	WT: 70/60 °C			WT: 60/50 °C			WT: 50/40 °C			WT: 50/45 °C			WT: 45/40 °C		
			Ph kW	Qw l/h	Dp(c) kPa	Ph kW	Qw l/h	Dp(c) kPa	Ph kW	Qw l/h	Dp(c) kPa	Ph kW	Qw l/h	Dp(c) kPa	Ph kW	Qw l/h	Dp(c) kPa
HP 14	10	730	9,18	789	24,2	7,03	605	15,6	4,88	420	8,5	5,61	965	36,4	4,54	781	25,6
	7,5	625	8,06	693	19,3	6,18	531	12,4	4,29	369	6,8	4,92	846	29,0	3,99	686	20,4
	5	515	6,82	587	14,4	5,24	451	9,3	3,65	314	5,1	4,17	717	21,6	3,38	581	15,2
	3	425	5,76	495	10,7	4,43	381	6,9	3,09	266	3,8	3,52	605	16,1	2,86	492	11,3
	1	350	4,85	417	7,9	3,73	321	5,1	2,60	224	2,8	2,96	509	11,8	2,41	415	8,4
HP 24	10	1250	15,00	1290	62,1	11,52	991	40,2	8,02	690	22	9,16	1576	93,3	7,43	1278	65,8
	7,5	1120	13,73	1181	53,1	10,54	906	34,4	7,35	632	18,8	8,38	1441	79,8	6,80	1170	56,3
	5	920	11,67	1004	39,9	8,96	771	25,8	6,26	538	14,2	7,13	1226	59,9	5,79	996	42,3
	3	760	9,92	853	30,0	7,63	656	19,4	5,33	458	10,7	6,06	1042	45,0	4,92	846	31,8
	1	610	8,19	704	21,4	6,31	543	13,9	4,41	379	7,7	5,01	862	32,2	4,07	700	22,8
HP 34	10	1450	17,44	1500	22,6	13,33	1146	14,5	9,22	793	7,9	10,65	1832	34,0	8,62	1483	23,9
	7,5	1425	17,19	1478	22,1	13,14	1130	14,2	9,10	783	7,7	10,50	1806	33,2	8,50	1462	23,3
	5	1180	14,71	1265	16,8	11,26	968	10,8	7,80	671	5,9	8,99	1546	25,2	7,28	1252	17,7
	3	985	12,63	1086	12,8	9,68	832	8,3	6,72	578	4,5	7,72	1328	19,3	6,25	1075	13,6
	1	770	10,27	883	8,9	7,88	678	5,8	5,48	471	3,1	6,28	1080	13,4	5,09	875	9,4

LEGEND

WT = Water temperature
Ph = Emission
Qw = Water flow
Dp(c) = Water pressure drop
Vdc = Inverter Power
Qv = Air flow

NOTE

For air side
pressure drop higher
than 0Pa use
correction factors
at page 40 and 41.

Heating emission of 1 row additional coil

Entering air temperature: 20°C – Available pressure: 0Pa

MODEL ECM	Vdc	WT: 80/70 °C			WT: 75/65 °C			WT: 70/60 °C			WT: 65/55 °C			WT: 60/50 °C			WT: 55/45 °C			
		Qv	Ph	Qw	Dp(c)	Ph	Qw	Dp(c)	Ph	Qw	Dp(c)	Ph	Qw	Dp(c)	Ph	Qw	Dp(c)	Ph	Qw	Dp(c)
		m³/h	kW	l/h	kPa	kW	l/h	kPa	kW	l/h	kPa	kW	l/h	kPa	kW	l/h	kPa	kW	l/h	kPa
HP 1	10	730	4,28	368	28,8	3,85	331	24,4	3,43	295	20,2	3,01	259	16,3	2,59	223	12,7	2,18	187	9,5
	7,5	625	3,94	339	25,0	3,56	306	21,1	3,17	273	17,5	2,78	239	14,1	2,39	206	11,0	2,01	173	8,2
	5	515	3,46	298	19,9	3,12	268	16,8	2,78	239	13,9	2,44	210	11,2	2,10	181	8,8	1,76	151	6,6
	3	425	3,03	261	15,7	2,73	235	13,3	2,44	210	11,0	2,14	184	8,9	1,84	158	7,0	1,55	133	5,2
	1	350	2,65	228	12,4	2,39	206	10,5	2,13	183	8,7	1,87	161	7,0	1,61	138	5,5	1,36	117	4,1
HP 2	10	1250	6,65	572	17,2	5,98	514	14,5	5,31	457	11,9	4,64	399	9,6	3,97	341	7,4	3,3	284	5,4
	7,5	1120	6,21	534	15,3	5,58	480	12,9	4,96	427	10,6	4,33	372	8,5	3,71	319	6,6	3,09	266	4,8
	5	920	5,59	481	12,7	5,02	432	10,7	4,46	384	8,8	3,90	335	7,1	3,34	287	5,5	2,79	240	4,0
	3	760	4,92	423	10,2	4,43	381	8,5	3,93	338	7,0	3,44	296	5,7	2,95	254	4,4	2,46	212	3,2
	1	610	4,23	364	7,8	3,81	328	6,6	3,38	291	5,4	2,96	255	4,3	2,54	218	3,4	2,12	182	2,5
HP 3	10	1450	7,83	673	19,2	7,05	606	16,2	6,28	540	13,4	5,50	473	10,8	4,73	407	8,4	3,96	341	6,3
	7,5	1425	7,78	669	19,0	7,01	603	16,0	6,24	537	13,3	5,47	470	10,7	4,70	404	8,3	3,94	339	6,2
	5	1180	6,91	594	15,4	6,22	535	13,0	5,54	476	10,8	4,86	418	8,7	4,18	359	6,8	3,5	301	5,0
	3	985	6,11	525	12,4	5,51	474	10,5	4,91	422	8,7	4,30	370	7,0	3,70	318	5,5	3,1	267	4,1
	1	770	5,17	445	9,2	4,66	401	7,8	4,15	357	6,5	3,64	313	5,2	3,13	269	4,1	2,63	226	3,0

Heating emission of 2 row additional coil

Entering air temperature: 20°C – Available pressure: 0Pa

MODEL ECM	Vdc	WT: 65/55 °C			WT: 60/50 °C			WT: 55/45 °C			WT: 50/40 °C			WT: 45/40 °C			WT: 45/35 °C			
		Qv	Ph	Qw	Dp(c)	Ph	Qw	Dp(c)	Ph	Qw	Dp(c)	Ph	Qw	Dp(c)	Ph	Qw	Dp(c)	Ph	Qw	Dp(c)
		m³/h	kW	l/h	kPa	kW	l/h	kPa	kW	l/h	kPa	kW	l/h	kPa	kW	l/h	kPa	kW	l/h	kPa
HP 1	10	730	5,22	449	7,5	4,49	386	5,9	3,77	324	4,4	3,05	262	3,1	2,92	502	9,7	2,33	200	2,0
	7,5	625	4,69	403	6,3	4,04	347	4,9	3,40	292	3,7	2,75	237	2,6	2,62	451	8,1	2,10	181	1,6
	5	515	4,10	353	4,9	3,53	304	3,9	2,97	255	2,9	2,41	207	2,0	2,29	394	6,4	1,84	158	1,3
	3	425	3,57	307	3,9	3,08	265	3,0	2,59	223	2,3	2,10	181	1,6	1,99	342	5,0	1,61	138	1,0
	1	350	3,09	266	3,0	2,67	230	2,3	2,24	193	1,8	1,82	157	1,2	1,73	298	3,9	1,40	120	0,8
HP 2	10	1250	8,50	731	24,7	7,35	632	19,4	6,19	532	14,6	5,04	433	10,3	4,76	819	32,0	3,88	334	6,7
	7,5	1120	7,91	680	21,7	6,83	587	17,1	5,76	495	12,9	4,69	403	9,1	4,42	760	28,1	3,61	310	5,9
	5	920	6,92	595	17,2	5,98	514	13,5	5,05	434	10,2	4,11	353	7,2	3,87	666	22,2	3,17	273	4,7
	3	760	6,06	521	13,6	5,24	451	10,7	4,42	380	8,1	3,60	310	5,7	3,39	583	17,6	2,78	239	3,7
	1	610	5,17	445	10,3	4,47	384	8,1	3,77	324	6,1	3,08	265	4,3	2,89	497	13,3	2,38	205	2,8
HP 3	10	1450	10,32	888	47,3	8,94	769	37,3	7,55	649	28,2	6,17	531	20,1	5,78	994	61,2	4,78	411	13,1
	7,5	1425	10,20	877	46,3	8,83	759	36,5	7,47	642	27,6	6,10	525	19,7	5,71	982	60,0	4,73	407	12,8
	5	1180	8,97	771	37,0	7,77	668	29,1	6,57	565	22,0	5,37	462	15,7	5,03	865	47,8	4,17	359	10,3
	3	985	7,91	680	29,6	6,85	589	23,4	5,80	499	17,7	4,74	408	12,6	4,43	762	38,3	3,68	316	8,2
	1	770	6,62	569	21,6	5,73	493	17,1	4,85	417	12,9	3,97	341	9,2	3,71	638	28,0	3,09	266	6,0

LEGEND

WT = Water temperature
 Ph = Emission
 Qw = Water flow
 Dp(c) = Water pressure drop
 Vdc = Inverter Power
 Qv = Air flow

NOTE

For air side
 pressure drop higher
 than 0Pa use
 correction factors
 at page 40 and 41.

**Air flow and emission correction factors
with different available pressure**

MODEL ECM		EMISSION CORRECTION FACTORS FOR HIGH SPEED FIGURES AT 10 V SIGNAL																												
		Vdc	Qv (m³/h)										K1										K2							
			Ap (Pa)										Ap (Pa)										Ap (Pa)							
		0	10	20	30	40	50	60	70	80	0	10	20	30	40	50	60	70	80	0	10	20	30	40	50	60	70	80		
HP 1	10	730	695	648	595	540	480	423	355	280	1,00	0,97	0,92	0,87	0,81	0,75	0,68	0,59	0,49	1,00	0,96	0,91	0,85	0,79	0,72	0,65	0,56	0,46		
	9,5	720	670	620	570	510	450	387	315	240	0,99	0,94	0,89	0,84	0,78	0,71	0,63	0,54	0,43	0,99	0,94	0,88	0,82	0,76	0,68	0,60	0,51	0,40		
	9	692	647	595	540	480	420	350	275	190	0,96	0,92	0,87	0,81	0,75	0,68	0,59	0,48	0,36	0,96	0,91	0,85	0,79	0,72	0,65	0,56	0,45	0,33		
	8,5	661	620	570	510	450	385	310	280	125	0,93	0,89	0,84	0,78	0,71	0,63	0,53	0,49	0,25	0,93	0,88	0,82	0,76	0,68	0,60	0,50	0,46	0,23		
	8	650	600	543	485	420	355	273	180	-	0,92	0,87	0,82	0,75	0,68	0,59	0,48	0,34	-	0,91	0,86	0,79	0,73	0,65	0,56	0,45	0,31	-		
	7,5	625	575	520	460	395	317	230	137	-	0,90	0,85	0,79	0,72	0,64	0,54	0,42	0,27	-	0,89	0,83	0,77	0,70	0,61	0,51	0,39	0,24	-		
	7	692	550	492	430	360	280	185	-	-	0,96	0,82	0,76	0,69	0,60	0,49	0,35	-	-	0,96	0,80	0,73	0,66	0,57	0,46	0,32	-	-		
	6,5	573	520	465	400	320	235	130	-	-	0,85	0,79	0,73	0,65	0,55	0,43	0,26	-	-	0,83	0,77	0,70	0,62	0,52	0,40	0,23	-	-		
	6	555	500	440	367	285	180	-	-	-	0,83	0,77	0,70	0,61	0,50	0,34	-	-	-	0,81	0,74	0,67	0,58	0,47	0,31	-	-	-		
	5,5	540	476	410	332	245	140	-	-	-	0,81	0,74	0,66	0,56	0,44	0,27	-	-	-	0,79	0,71	0,63	0,53	0,41	0,25	-	-	-		
	5	515	450	380	296	200	-	-	-	-	0,78	0,71	0,63	0,51	0,37	-	-	-	-	0,76	0,68	0,60	0,48	0,34	-	-	-	-		
	4	472	400	320	226	105	-	-	-	-	0,74	0,65	0,55	0,41	0,21	-	-	-	-	0,71	0,62	0,52	0,38	0,19	-	-	-	-		
3	425	347	252	132	-	-	-	-	-	0,68	0,58	0,45	0,26	-	-	-	-	-	0,65	0,55	0,42	0,24	-	-	-	-	-			
2	384	295	187	-	-	-	-	-	-	0,63	0,51	0,35	-	-	-	-	-	-	0,60	0,48	0,32	-	-	-	-	-	-			
1	350	250	115	-	-	-	-	-	-	0,59	0,45	0,23	-	-	-	-	-	-	0,56	0,42	0,21	-	-	-	-	-	-			
HP 2	10	1250	1195	1140	1075	1010	940	860	780	680	1,00	0,97	0,94	0,91	0,87	0,83	0,78	0,73	0,66	1,00	0,97	0,93	0,89	0,85	0,80	0,75	0,69	0,62		
	9,5	1245	1075	1115	1050	980	900	820	722	715	1,00	0,96	0,93	0,89	0,85	0,80	0,75	0,69	0,68	1,00	0,95	0,92	0,87	0,83	0,78	0,72	0,65	0,65		
	9	1220	1155	1090	1020	945	860	770	665	535	0,98	0,95	0,91	0,87	0,83	0,78	0,72	0,65	0,55	0,98	0,94	0,90	0,86	0,81	0,75	0,69	0,61	0,51		
	8,5	1200	1135	1065	990	907	815	715	593	440	0,97	0,94	0,90	0,86	0,81	0,75	0,68	0,59	0,47	0,97	0,93	0,88	0,84	0,78	0,72	0,65	0,55	0,43		
	8	1160	1092	1020	940	853	755	645	510	315	0,95	0,92	0,87	0,83	0,77	0,71	0,63	0,53	0,36	0,94	0,90	0,86	0,80	0,74	0,67	0,59	0,49	0,32		
	7,5	1120	1048	970	890	800	695	570	410	-	0,93	0,89	0,85	0,80	0,74	0,67	0,58	0,44	-	0,92	0,87	0,82	0,77	0,71	0,63	0,54	0,40	-		
	7	1080	1005	927	840	740	630	490	300	-	0,91	0,87	0,82	0,77	0,70	0,62	0,51	0,34	-	0,89	0,85	0,79	0,73	0,66	0,58	0,47	0,31	-		
	6,5	1040	960	880	785	685	560	400	-	-	0,89	0,84	0,79	0,73	0,66	0,57	0,44	-	-	0,87	0,82	0,76	0,70	0,62	0,53	0,40	-	-		
	6	1000	920	835	735	625	485	285	-	-	0,86	0,82	0,76	0,70	0,62	0,51	0,33	-	-	0,84	0,79	0,73	0,66	0,58	0,47	0,29	-	-		
	5,5	960	880	785	685	560	400	-	-	-	0,84	0,79	0,73	0,66	0,57	0,44	-	-	-	0,82	0,76	0,70	0,62	0,53	0,40	-	-	-		
	5	920	830	737	625	495	300	-	-	-	0,82	0,76	0,70	0,62	0,52	0,34	-	-	-	0,79	0,73	0,66	0,58	0,48	0,31	-	-	-		
	4	840	750	640	510	340	-	-	-	-	0,77	0,71	0,63	0,53	0,38	-	-	-	-	0,73	0,67	0,59	0,49	0,34	-	-	-	-		
3	760	655	535	370	-	-	-	-	-	0,71	0,64	0,55	0,41	-	-	-	-	-	0,68	0,60	0,51	0,37	-	-	-	-	-			
2	680	560	400	160	-	-	-	-	-	0,66	0,57	0,44	0,20	-	-	-	-	-	0,62	0,53	0,40	0,18	-	-	-	-	-			
1	610	475	280	-	-	-	-	-	-	0,61	0,50	0,32	-	-	-	-	-	-	0,57	0,46	0,29	-	-	-	-	-	-			
HP 3	10	1450	1395	1350	1310	1260	1205	1145	1075	990	1,00	0,97	0,95	0,93	0,91	0,88	0,85	0,82	0,77	1,00	0,97	0,95	0,92	0,90	0,87	0,83	0,79	0,74		
	9,5	1445	1390	1345	1295	1245	1185	1115	1030	935	1,00	0,97	0,95	0,93	0,90	0,87	0,84	0,79	0,74	1,00	0,97	0,94	0,92	0,89	0,85	0,81	0,76	0,71		
	9	1440	1385	1340	1280	1225	1155	1075	975	850	0,99	0,97	0,95	0,92	0,89	0,86	0,82	0,76	0,69	0,99	0,96	0,94	0,91	0,88	0,84	0,79	0,73	0,65		
	8,5	1435	1380	1335	1270	1195	1110	1015	900	750	0,99	0,97	0,95	0,91	0,88	0,83	0,78	0,72	0,63	0,99	0,96	0,94	0,90	0,86	0,81	0,76	0,69	0,59		
	8	1430	1370	1305	1230	1145	1050	940	800	630	0,99	0,96	0,93	0,90	0,85	0,80	0,74	0,66	0,55	0,99	0,96	0,92	0,88	0,83	0,78	0,71	0,62	0,51		
	7,5	1425	1345	1265	1180	1085	970	845	690	500	0,99	0,95	0,91	0,87	0,82	0,76	0,69	0,59	0,46	0,99	0,94	0,90	0,85	0,80	0,73	0,65	0,55	0,42		
	7	1360	1290	1210	1120	1015	895	760	590	-	0,96	0,92	0,89	0,84	0,78	0,72	0,63	0,52	-	0,95	0,91	0,87	0,82	0,76	0,68	0,60	0,48	-		
	6,5	1320	1240	1160	1060	955	825	660	460	-	0,94	0,90	0,86	0,81	0,75	0,67	0,57	0,43	-	0,93	0,89	0,84	0,78	0,72	0,64	0,53	0,39	-		
	6	1270	1190	1100	995	880	735	570	-	-	0,91	0,88	0,83	0,77	0,71	0,62	0,51	-	-	0,90	0,86	0,81	0,74	0,67	0,58	0,47	-	-		
	5,5	1220	1140	1040	930	800	645	450	-	-	0,89	0,85	0,80	0,74	0,66	0,56	0,42	-	-	0,87	0,83	0,77	0,70	0,62	0,52	0,38	-	-		
	5	1180	1080	980	865	725	545	-	-	-	0,87	0,82	0,76	0,70	0,61	0,49	-	-	-	0,85	0,79	0,73	0,66	0,57	0,45	-	-	-		
	4	1080	982	870	730	560	350	-	-	-	0,82	0,77	0,70	0,62	0,50	0,34	-	-	-	0,79	0,74	0,67	0,58	0,46	0,31	-	-	-		
3	985	875	745	570	350	-	-	-	-	0,77	0,70	0,63	0,51	0,34	-	-	-	-	0,74	0,67	0,59	0,47	0,31	-	-	-	-			
2	890	760	595	-	-	-	-	-	-	0,71	0,63	0,53	-	-	-	-	-	-	0,68	0,60	0,49	-	-	-	-	-	-			
1	770	600	405	-	-	-	-	-	-	0,64	0,53	0,39	-	-	-	-	-	-	0,60	0,49	0,35	-	-	-	-	-	-			

LEGEND

- Qv = Air flow
- K1 = Correction factors for Total cooling emission
- K2 = Correction factors for Sensible cooling emission and Heating emission
- Ap = Available pressure
- Vdc = Inverter Power

**Air flow table, correction factors for emission
and Watts absorbed by the motor with different available pressures**

MODEL ECM	Vdc	Qv (m³/h)										Qv %								W								
		Ap (Pa)										Ap (Pa)								Ap (Pa)								
		0	10	20	30	40	50	60	70	80	0	10	20	30	40	50	60	70	80	0	10	20	30	40	50	60	70	80
HP 1	10	730	695	648	595	540	480	423	355	280	1,00	0,95	0,89	0,82	0,74	0,66	0,58	0,49	0,38	80	77	73	68	63	59	54	49	44
	9,5	720	670	620	570	510	450	387	315	240	0,99	0,92	0,85	0,78	0,70	0,62	0,53	0,43	0,33	75	71	67	63	58	53	49	44	40
	9	692	647	595	540	480	420	350	275	190	0,95	0,89	0,82	0,74	0,66	0,58	0,48	0,38	0,26	69	65	61	57	53	49	44	40	35
	8,5	661	620	570	510	450	385	310	280	125	0,91	0,85	0,78	0,70	0,62	0,53	0,42	0,38	0,17	63	60	56	52	48	44	39	38	30
	8	650	600	543	485	420	355	273	180	-	0,89	0,82	0,74	0,66	0,58	0,49	0,37	0,25	-	59	55	51	47	43	40	35	31	-
	7,5	625	575	520	460	395	317	230	137	-	0,86	0,79	0,71	0,63	0,54	0,43	0,32	0,19	-	54	51	47	43	39	35	31	27	-
	7	692	550	492	430	360	280	185	-	-	0,95	0,75	0,67	0,59	0,49	0,38	0,25	-	-	55	46	43	39	35	32	27	-	-
	6,5	573	520	465	400	320	235	130	-	-	0,78	0,71	0,64	0,55	0,44	0,32	0,18	-	-	44	42	39	36	32	28	24	-	-
	6	555	500	440	367	285	180	-	-	-	0,76	0,68	0,60	0,50	0,39	0,25	-	-	-	41	38	35	32	29	25	-	-	-
	5,5	540	476	410	332	245	140	-	-	-	0,74	0,65	0,56	0,45	0,34	0,19	-	-	-	38	35	32	29	25	22	-	-	-
	5	515	450	380	296	200	-	-	-	-	0,71	0,62	0,52	0,41	0,27	-	-	-	-	35	32	29	26	22	-	-	-	-
	4	472	400	320	226	105	-	-	-	-	0,65	0,55	0,44	0,31	0,14	-	-	-	-	29	26	23	20	17	-	-	-	-
3	425	347	252	132	-	-	-	-	-	0,58	0,48	0,35	0,18	-	-	-	-	-	24	21	18	15	-	-	-	-	-	
2	384	295	187	-	-	-	-	-	-	0,53	0,40	0,26	-	-	-	-	-	-	20	17	15	-	-	-	-	-	-	
1	350	250	115	-	-	-	-	-	-	0,48	0,34	0,16	-	-	-	-	-	-	17	14	12	-	-	-	-	-	-	
HP 2	10	1250	1195	1140	1075	1010	940	860	780	680	1,00	0,96	0,91	0,86	0,81	0,75	0,69	0,62	0,54	132	132	131	125	119	113	106	99	91
	9,5	1245	1075	1115	1050	980	900	820	722	715	1,00	0,94	0,89	0,84	0,78	0,72	0,66	0,58	0,57	132	128	123	117	111	104	97	89	89
	9	1220	1155	1090	1020	945	860	770	665	535	0,98	0,92	0,87	0,82	0,76	0,69	0,62	0,53	0,43	126	121	115	109	103	96	89	81	71
	8,5	1200	1135	1065	990	907	815	715	593	440	0,96	0,91	0,85	0,79	0,73	0,65	0,57	0,47	0,35	119	113	107	101	94	87	80	71	61
	8	1160	1092	1020	940	853	755	645	510	315	0,93	0,87	0,82	0,75	0,68	0,60	0,52	0,41	0,25	109	103	97	91	85	78	70	61	49
	7,5	1120	1048	970	890	800	695	570	410	-	0,90	0,84	0,78	0,71	0,64	0,56	0,46	0,33	-	99	93	88	82	76	68	60	51	-
	7	1080	1005	927	840	740	630	490	300	-	0,86	0,80	0,74	0,67	0,59	0,50	0,39	0,24	-	88	83	78	72	66	60	52	42	-
	6,5	1040	960	880	785	685	560	400	-	-	0,83	0,77	0,70	0,63	0,55	0,45	0,32	-	-	78	73	69	64	58	52	44	-	-
	6	1000	920	835	735	625	485	285	-	-	0,80	0,74	0,67	0,59	0,50	0,39	0,23	-	-	71	67	62	57	51	44	35	-	-
	5,5	960	880	785	685	560	400	-	-	-	0,77	0,70	0,63	0,55	0,45	0,32	-	-	-	64	60	55	50	44	37	-	-	-
	5	920	830	737	625	495	300	-	-	-	0,74	0,66	0,59	0,50	0,40	0,24	-	-	-	58	53	49	44	38	30	-	-	-
	4	840	750	640	510	340	-	-	-	-	0,67	0,60	0,51	0,41	0,27	-	-	-	-	47	43	38	33	28	-	-	-	-
3	760	655	535	370	-	-	-	-	-	0,61	0,52	0,43	0,30	-	-	-	-	-	37	33	29	24	-	-	-	-	-	
2	680	560	400	160	-	-	-	-	-	0,54	0,45	0,32	0,13	-	-	-	-	-	29	25	21	16	-	-	-	-	-	
1	610	475	280	-	-	-	-	-	-	0,49	0,38	0,22	-	-	-	-	-	-	23	19	16	-	-	-	-	-	-	
HP 3	10	1450	1395	1350	1310	1260	1205	1145	1075	990	1,00	0,96	0,93	0,90	0,87	0,83	0,79	0,74	0,68	136	136	136	136	136	136	134	130	124
	9,5	1445	1390	1345	1295	1245	1185	1115	1030	935	1,00	0,96	0,93	0,89	0,86	0,82	0,77	0,71	0,64	136	136	136	136	134	131	126	121	114
	9	1440	1385	1340	1280	1225	1155	1075	975	850	0,99	0,96	0,92	0,88	0,84	0,80	0,74	0,67	0,59	134	134	134	131	128	123	118	111	101
	8,5	1435	1380	1335	1270	1195	1110	1015	900	750	0,99	0,95	0,92	0,88	0,82	0,77	0,70	0,62	0,52	132	132	130	126	121	115	108	99	88
	8	1430	1370	1305	1230	1145	1050	940	800	630	0,99	0,94	0,90	0,85	0,79	0,72	0,65	0,55	0,43	129	125	121	116	110	103	95	86	74
	7,5	1425	1345	1265	1180	1085	970	845	690	500	0,98	0,93	0,87	0,81	0,75	0,67	0,58	0,48	0,34	122	116	111	105	98	91	82	73	62
	7	1360	1290	1210	1120	1015	895	760	590	-	0,94	0,89	0,83	0,77	0,70	0,62	0,52	0,41	-	111	106	101	95	88	81	72	62	-
	6,5	1320	1240	1160	1060	955	825	660	460	-	0,91	0,86	0,80	0,73	0,66	0,57	0,46	0,32	-	102	97	92	86	80	72	62	51	-
	6	1270	1190	1100	995	880	735	570	-	-	0,88	0,82	0,76	0,69	0,61	0,51	0,39	-	-	93	88	83	77	70	62	54	-	-
	5,5	1220	1140	1040	930	800	645	450	-	-	0,84	0,79	0,72	0,64	0,55	0,44	0,31	-	-	84	80	75	69	62	54	45	-	-
	5	1180	1080	980	865	725	545	-	-	-	0,81	0,74	0,68	0,60	0,50	0,38	-	-	-	76	71	66	61	54	46	-	-	-
	4	1080	982	870	730	560	350	-	-	-	0,74	0,68	0,60	0,50	0,39	0,24	-	-	-	62	58	53	47	41	33	-	-	-
3	985	875	745	570	350	-	-	-	-	0,68	0,60	0,51	0,39	0,24	-	-	-	-	49	45	40	35	29	-	-	-	-	
2	890	760	595	-	-	-	-	-	-	0,61	0,52	0,41	-	-	-	-	-	-	39	35	31	-	-	-	-	-	-	
1	770	600	405	-	-	-	-	-	-	0,53	0,41	0,28	-	-	-	-	-	-	30	26	21	-	-	-	-	-	-	

LEGEND

- Qv = Air flow
- Qv % = Correction factors for Air flow
- W = Watts absorbed by the motor
- Ap = Available pressure
- Vdc = Inverter Power

Water pressure drop

3 row coil

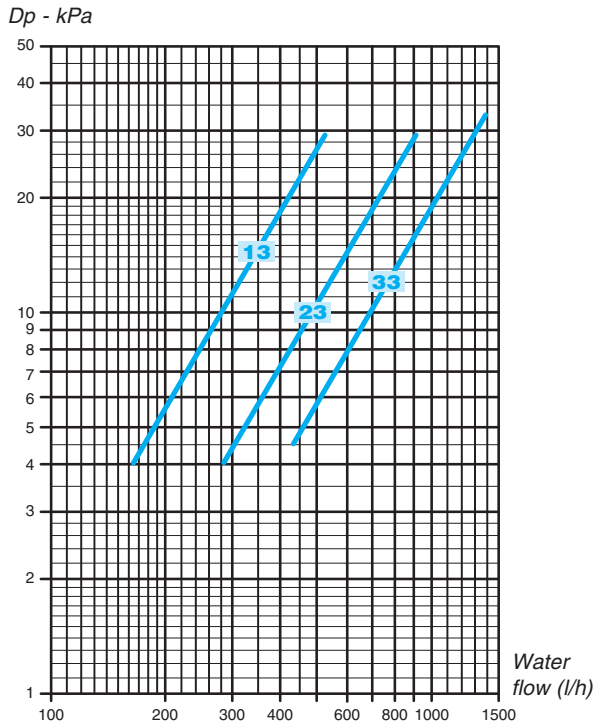

4 row coil

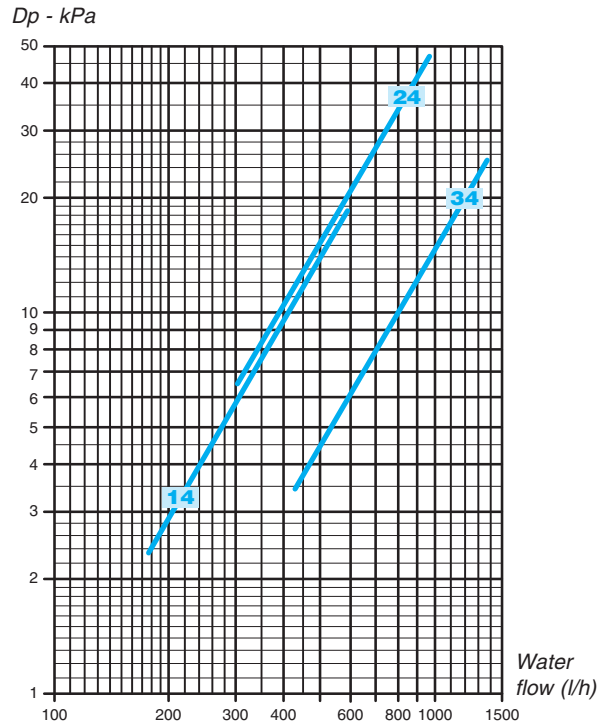

The water pressure drop figures refer to a mean water temperature of **10°C**; for different temperatures, multiply the pressure drop figures by the correction factors **K**.

°C	20	30	40	50	60	70	80
K	0,94	0,90	0,86	0,82	0,78	0,74	0,70

1 row additional coil

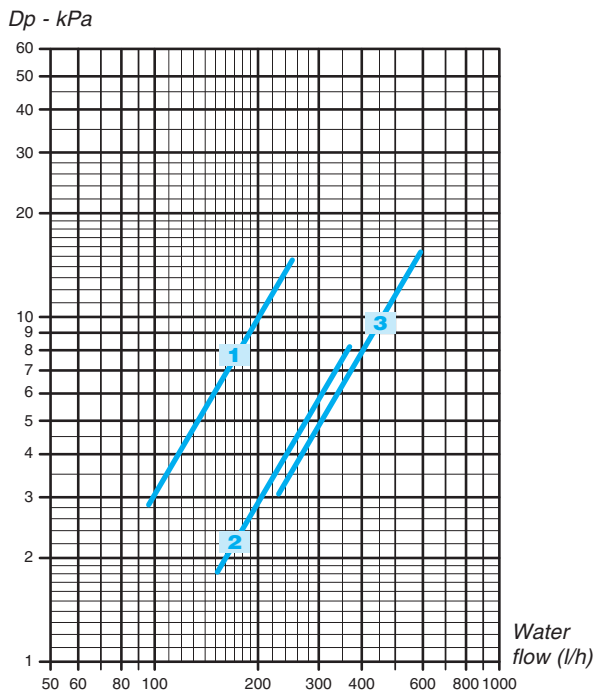

2 row additional coil

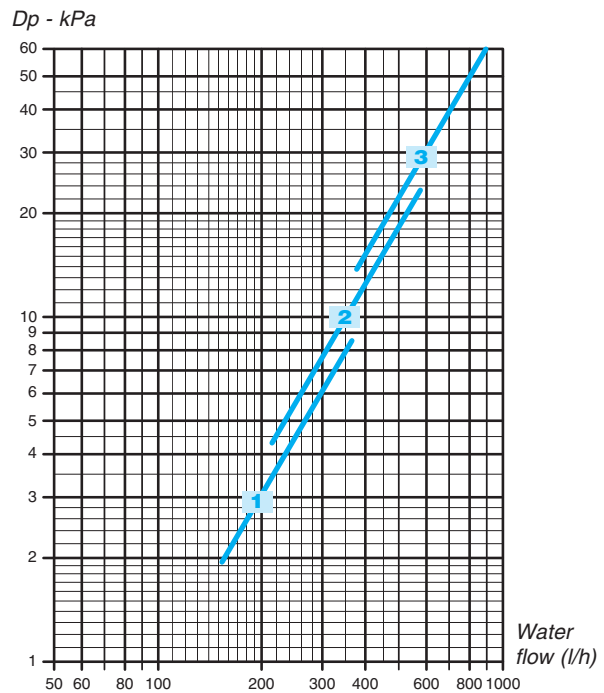

The water pressure drop figures refer to a mean water temperature of **60°C**; for different temperatures, multiply the pressure drop figures by the correction factors **K**.

°C	40	50	70	80
K	1,12	1,06	0,94	0,88

ACCESSORIES AND CONTROLS FOR:

SEC-ECM version with centrifugal fan

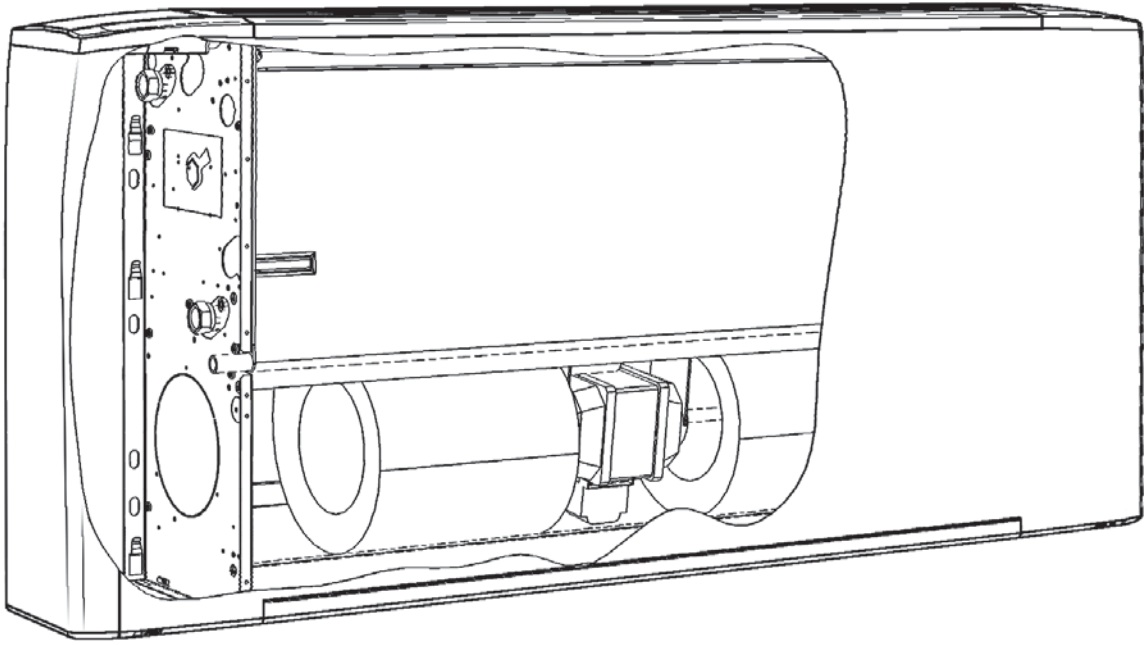

HP-ECM version with high pressure centrifugal fan

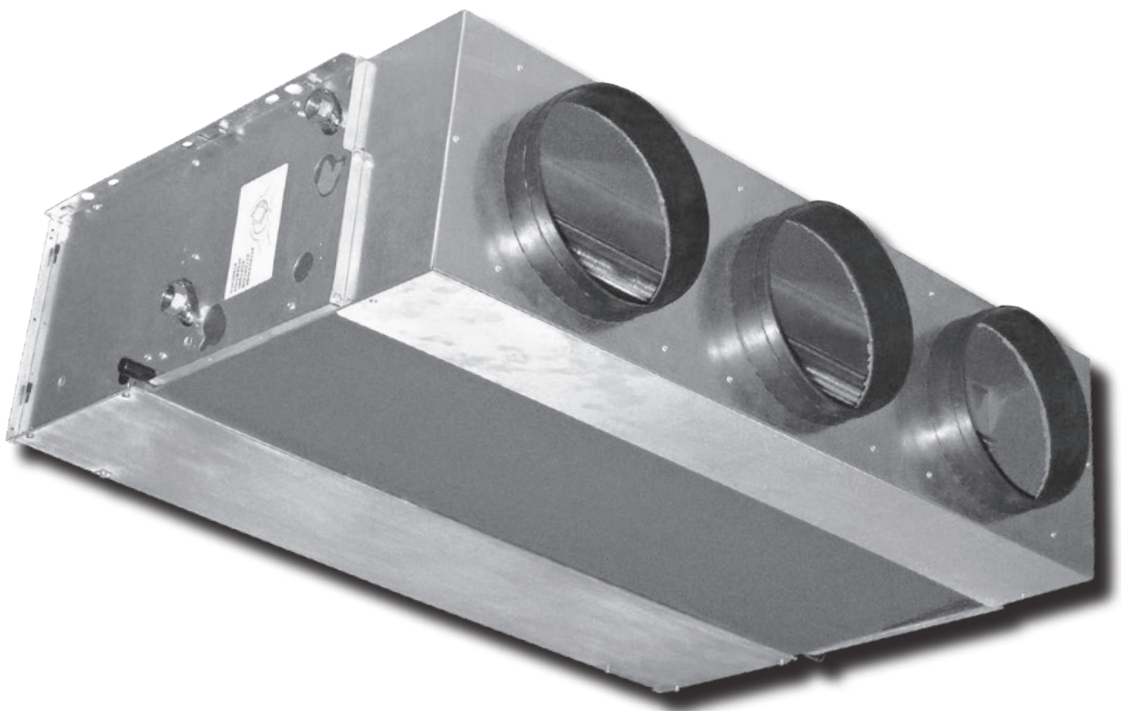

VBP main coil 3 way valve

Control valve kit:
3 way valve, ON-OFF,
with electric motor and mounting kit
with micrometric lockshield valve.

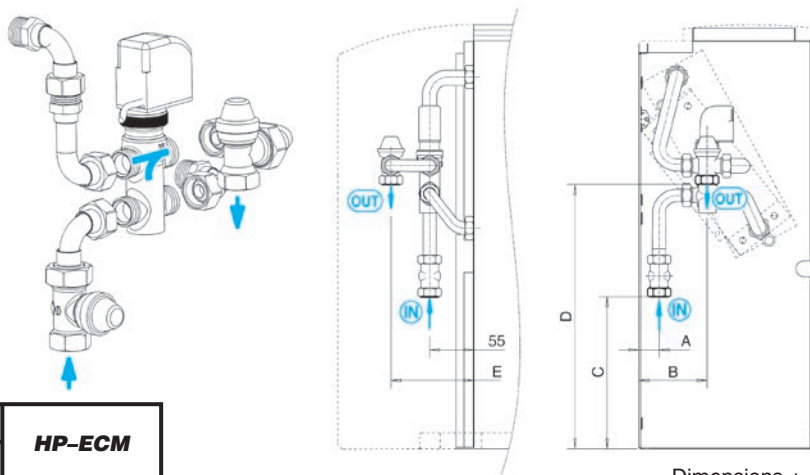

Dimensions ± 10 mm

VERSION	SEC-ECM	HP-ECM
MODEL	CV - CH - CVB - NC	

Mod.		Dimensions (mm)					Valve			Micrometric lockshield valve			Code	
SEC	HP	A	B	C	D	E	DN	(Ø)	Kvs	DN	(Ø)	Kvs	FITTED	NOT FITTED
2 - 4	1	25	85	190	290	105	15	1/2"	1,6	15	1/2" F	2	9066561H	9066560H
6 - 7	2	25	85	190	290	105	20	3/4"	2,5	15	1/2" F	2	9060471H	9060474H
9	3	50	120	185	290	105	20	3/4"	2,5	15	1/2" F	2	9060471H	9060474H

VBA additional coil 3 way valve

Control valve kit:
3 way valve, ON-OFF,
with electric motor and mounting kit
with micrometric lockshield valve.

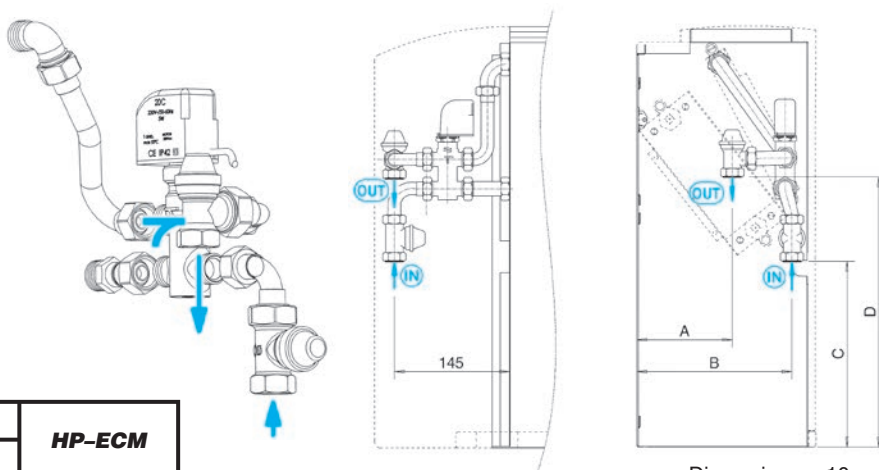

Dimensions ± 10 mm

VERSION	SEC-ECM	HP-ECM
MODEL	CV - CH - CVB - NC	

Mod.		Dimensions (mm)				Valve			Micrometric lockshield valve			Code	
SEC	HP	A	B	C	D	DN	(Ø)	Kvs	DN	(Ø)	Kvs	FITTED	NOT FITTED
2 ÷ 7	1 - 2	120	195	240	340	15	1/2"	1,6	15	1/2" F	2	9060472H	9060475H
9	3	135	200	235	330	15	1/2"	1,6	15	1/2" F	2	9060472H	9060475H

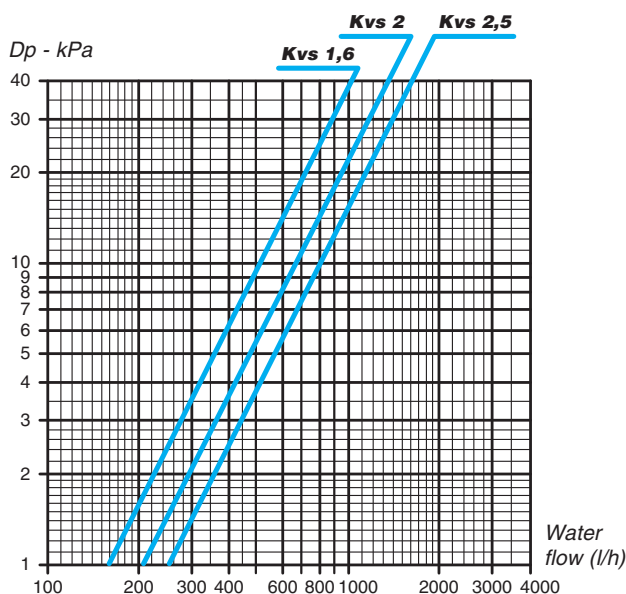

VS simplified kit for 3 way valve (concealed model only)

3 way valve, (ON-OFF)
with electric motor and mounting kit.
Valve with flat connection
without micrometric lockshield valve.

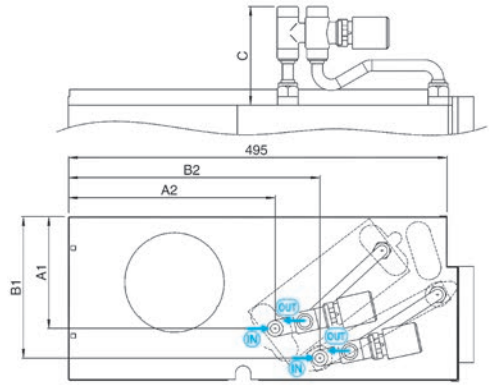
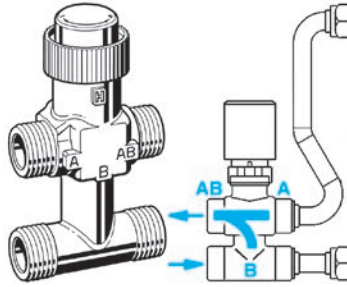

Dimensions ± 10 mm

VERSION	SEC-ECM	HP-ECM
MODEL	NC	

MOD.		Dimensions (mm)					MAIN				ADDITIONAL					
		MAIN		ADDITIONAL			Valve		Code		Valve		Code			
SEC	HP	A1	A2	B1	B2	C	DN	(Ø)	Kvs	FITTED	NOT FITTED	DN	(Ø)	Kvs	FITTED	NOT FITTED
2 - 4	1	152	270	185	330	116	15	1/2"	1,6	9066571H	9066570H	15	1/2"	1,6	9060483H	9060480H
6 - 7	2	152	268	185	330	124	20	3/4"	2,5	9060484H	9060481H					
9	3	177	270	210	327	124	20	3/4"	2,5	9060484H	9060481H					

V2 2 way valve for main and additional coil

Control valve kit:
2 way valve, ON-OFF,
with electric motor and mounting kit.

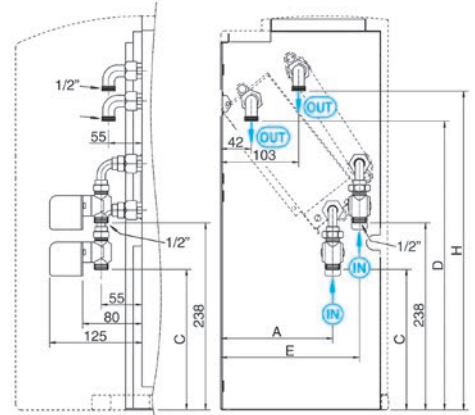
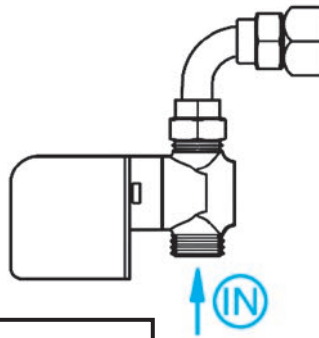

Dimensions ± 10 mm

VERSION	SEC-ECM	HP-ECM
MODEL	CV - CH - CVB - NC	

MOD.		Dimensions (mm)					MAIN				ADDITIONAL					
		MAIN		ADDITIONAL			Valve		Code		Valve		Code			
SEC	HP	A	C	D	E	H	DN	(Ø)	Kvs	FITTED	NOT FITTED	DN	(Ø)	Kvs	FITTED	NOT FITTED
2 - 4	1	149	180	438	186	456	15	1/2"	1,7	9066573H	9066575H	15	1/2"	1,7	9066573H	9066575H
6 - 7	2	150	181	438	186	456	20	3/4"	2,8	9066574H	9066576H					
9	3	176	175	422	210	440	20	3/4"	2,8	9066574H	9066576H					

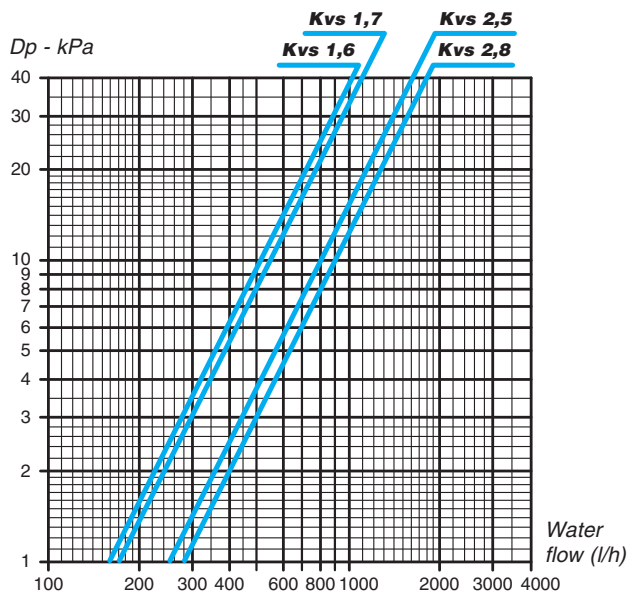

3 way double valve kit for 4 tube installation and single coil

The kit consists of:

- 2 special 3 way valves;
- 2 230 Volt ON-OFF actuators with internal safety micro switch;
- insulated pipe kit;
- external valve insulation sleeve.

VERSION	SEC-ECM	HP-ECM
MODEL	CV - CH - CVB - NC	

-ECM Mod.		Ø	Kvs	FITTED		NOT FITTED	
SEC	HP			CODE	TYPE	CODE	TYPE
1 ÷ 9	1 ÷ 3	3/4"	2,2	9066572W	V3M4X2	9066562W	V3S4X2

The kit uses a special 3 way valve which allows the transformation of the fan coil, equipped with one single coil, into a 4 tube installation.

The new **4X2** valve has been designed to keep the water flow between flow and return perfectly separated, allowing its use in parallel.

Therefore, it can be used on 4 pipe fan coil systems with one single heat-exchange coil on board the fan coil.

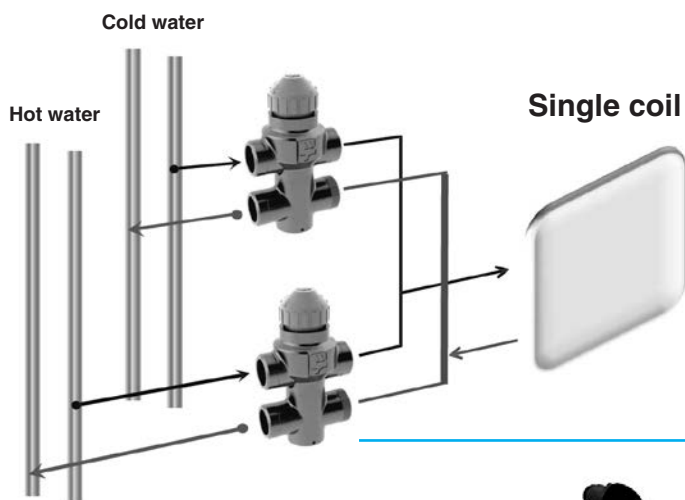
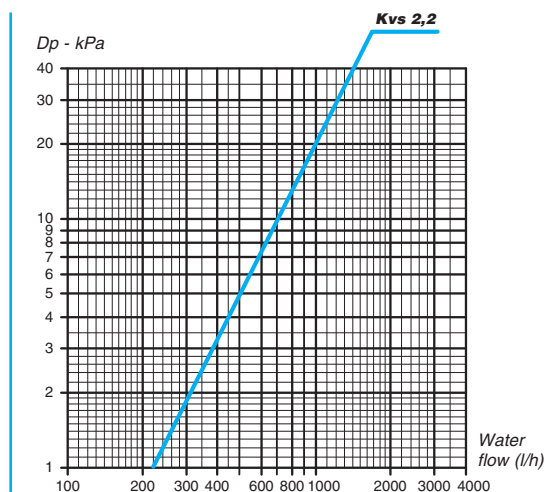

Double actuator electrical connections

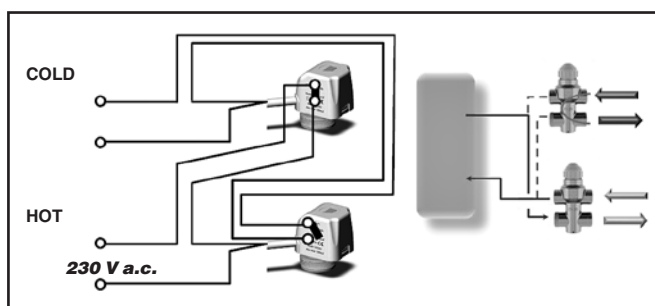
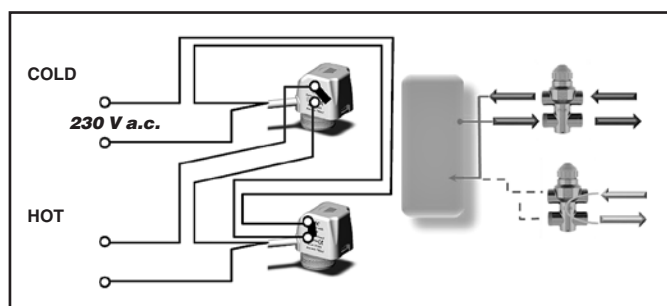

Balancing valves independent from the system pressure

- The balancing valve and a combined 2 way valve allow the regulation of the water flow value autonomously, regardless of the system pressure, and the control of the flow by using an ON/OFF electro-thermal actuator.
- The balancing valve allows you to balance the hydraulic system by supplying the required water flow, for each fan- coil, and to maintain it even under partial load conditions.
- A graduated ring nut placed under the valve allows you to set the flow rate value and also allows direct reading of the set value.



Valve operation logic

- “p1” is the valve inlet pressure.
- “p3” is the outlet pressure.
- “p2” is the diaphragm activation pressure, which allows differential pressure “p2” – “p3” to be maintained at a constant value, in order to guarantee the water to flow at the set value.

The minimum differential pressure “p1” – “p3”, required to guarantee the correct value of the set water flow rate, is indicated in the diagrams on page 48. This is an essential factor to size the system pressure drop and pump pressure head. The flow rate is kept at a constant value only if the valve pressure drop is higher than the indicated value.

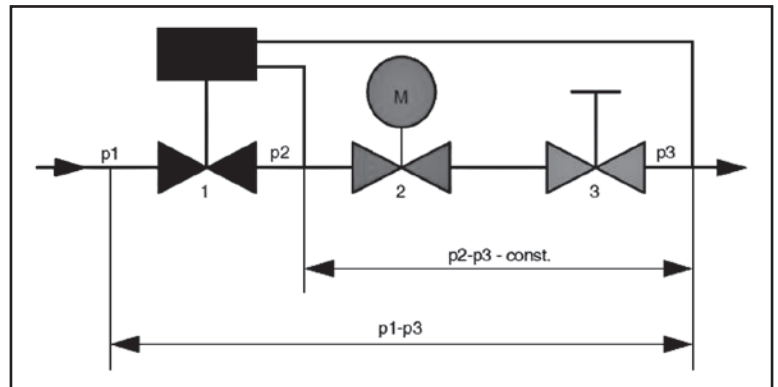

Minimum operating differential pressure

The minimum differential pressure and the balancing valve pressure drop must be considered to size the system pumps.

Flow rate is constant if the pressure drop is higher than that indicated in the diagrams on page 48.

The following diagram shows an example of the flow rate trend according to the pressure drop and calibration required.

Example DN 10 Model

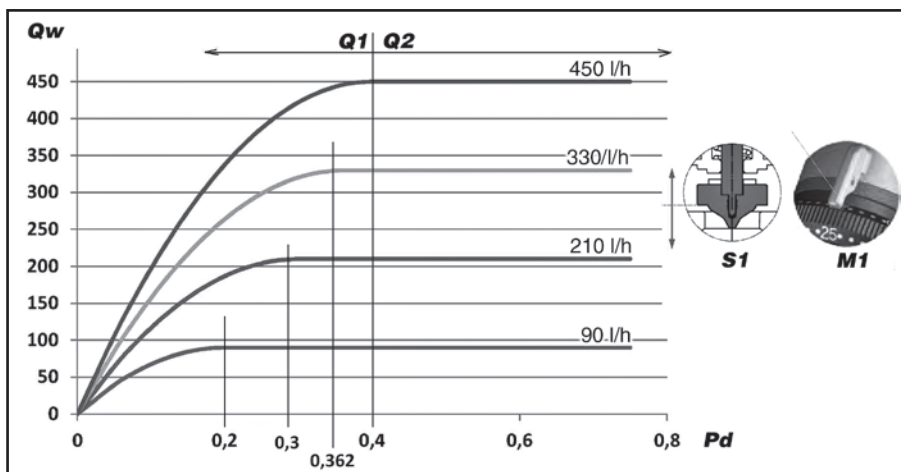

LEGEND:

- Qw** = Water flow rate
- Pd** = Min. differential pressure “p1” – “p3” (bar)
- Q1** = Area with inconstant water flow
- Q2** = Area with constant water flow
- S1** = Position of the adjustment valve plunger
- M1** = Position of the knob

Accessories for **SEC-ECM / HP-ECM** version

The valve upstream-downstream minimum differential pressure (“p1” – “p3”), which depends on the valve calibration value, must be exceeded to access the constant flow rate field.

DN 10 Model

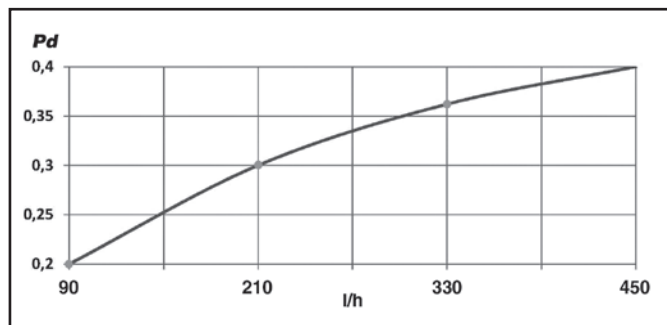

DN 15 Model

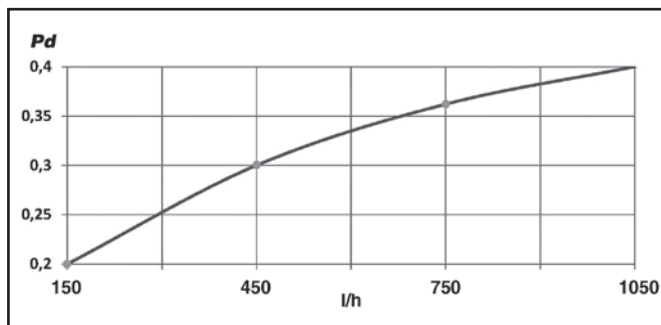

DN 20 Model

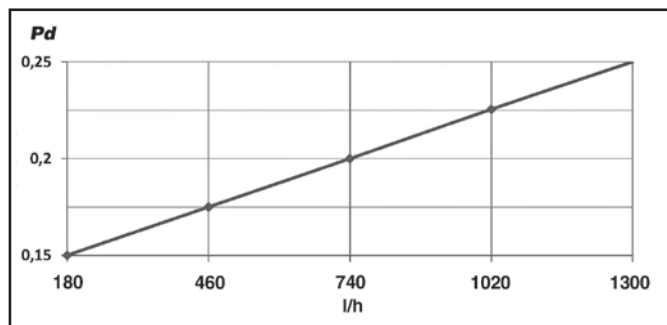

LEGEND:

Pd = Min. differential pressure “p1” – ”p3” (bar)

E.g., when sizing the system pump, in which the **DN 10** valves will be installed and in which 210 l/h are constantly required for each device, consider a useful pressure of 0.3 bar (to compensate the pressure drop of the valve) for each balancing valve. Therefore, the pressure drop values produced by the system balancing valves must be summed and the pump must be sized to produce a pressure equal to or greater than the value obtained previously.

Benefits

- Reduced dimensions.
- Easy installation on 2 or 4 pipe devices.
- Pre-regulation of the nominal value set even with installed actuator.
- Easy display of the nominal value set. Nominal values are indicated in 10 l/h without any conversion.
- Guarantee of constant flow rate set even with partial loads.
- Pre-regulation can be blocked and leaded with the locking ring.

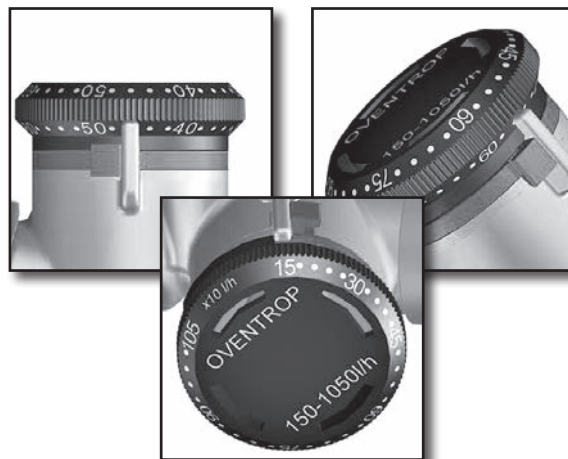

Technical features

DN MODEL	FLOW RATE RANGE (l/h)	Kvs
DN 10	90 – 450	1,1
DN 15	150 – 1050	1,8
DN 20	180 – 1300	2,5

Operation limits of the balancing valves

- Maximum operating temperature 120°C
- Maximum operating pressure 16 bar
- Maximum % of water/glycol mixture 50%
- Minimum operating temperature -10°C
- Maximum differential pressure 4 bar

Balancing valves for main coil

2 way valve for main coil and assembly kit.
The valve is supplied equipped with
230 Volt electro-thermal actuator for the ON/OFF control.

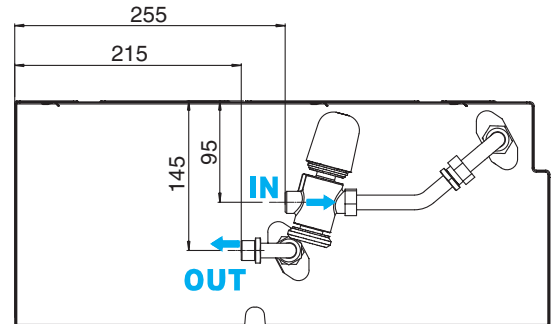
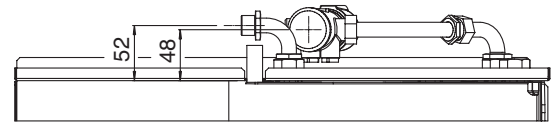

VERSION	SEC-ECM	HP-ECM
MODEL	CV - CH - CVB - NC	

-ECM Mod.		VALVE			FITTED		NOT FITTED	
SEC	HP	DN	Ø	Range	CODE	TYPE	CODE	TYPE
1 ÷ 3	1	10	1/2"	90 – 450	9066660	V2OVBPM 90-450	9066650	V2OVBPS 90-450
4 ÷ 7	2 - 3	15	3/4"	150 – 1050	9066661	V2OVBPM 150-1050	9066651	V2OVBPS 150-1050
8 - 9	-	20	1"	180 – 1300	9066662	V2OVBPM 180-1300	9066652	V2OVBPS 180-1300

Balancing valves for additional coil

2 way valve for additional coil and assembly kit.
The valve is supplied equipped with
230 Volt electro-thermal actuator for the ON/OFF control.

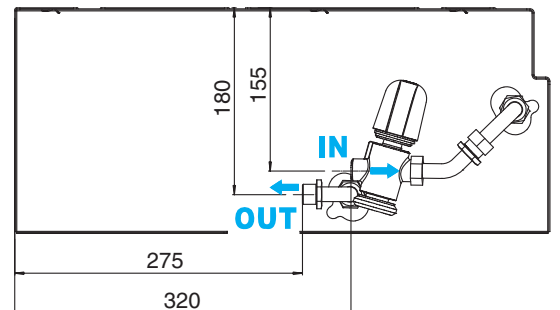
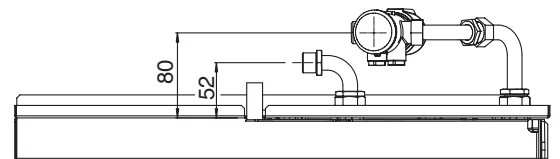

VERSION	SEC-ECM	HP-ECM
MODEL	CV - CH - CVB - NC	

-ECM Mod.		VALVE			FITTED		NOT FITTED	
SEC	HP	DN	Ø	Range	CODE	TYPE	CODE	TYPE
1 ÷ 5	1 ÷ 3	10	1/2"	90 – 450	9066663	V2OVBAM 90-450	9066653	V2OVBAS 90-450
6 ÷ 9	-	15	3/4"	150 – 1050	9066664	V2OVBAM 150-1050	9066654	V2OVBAS 150-1050

2 pipe system

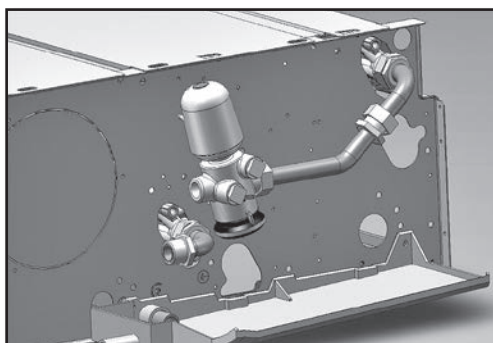

4 pipe system

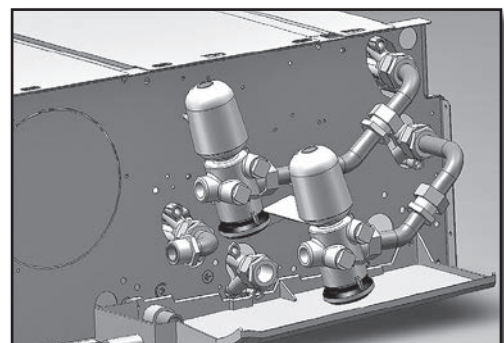

BEL electric heater

1 PHASE 230V

Electric heater with integral: safety thermostat and relay control.

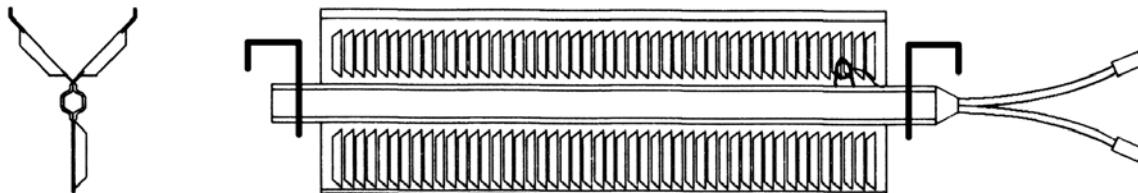

VERSION	SEC-ECM
MODEL	CV - CH - CVB - NC

VERSION	SEC-ECM	HP-ECM
MODEL	NC	

SIZE		
SEC-ECM	WATT	CODE
-	650	9066491E
2	1000	9066492E
	600	9066482E
	400	9066472E
4	1500	9066493E
	900	9066483E
	600	9066473E
6	2000	9066495E
	1250	9066485E
	750	9066475E
7 - 9	2500	9066497E
	1500	9066487E
	1000	9066477E

SIZE			
SEC-ECM	HP-ECM	WATT	CODE
-	-	650	9066611
2	-	1000	9066612
		600	9066602
		400	9066592
4	1	1500	9066613
		900	9066603
		600	9066593
6	2	2000	9066615
		1250	9066605
		750	9066595
7 - 9	3	2500	9066617
		1500	9066607
		1000	9066597

NOTE: for ECM range the controls can control the electric heater only if there is no hot water supply.

BSV-C extension condensate collection tray to cover valve assembly (for vertical units)

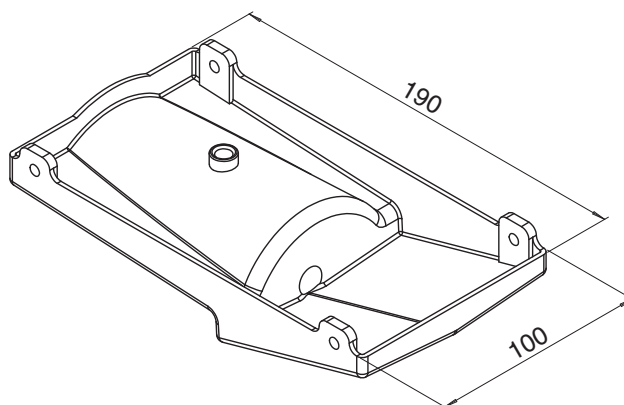

VERSION	SEC-ECM
MODEL	CV - CVB - NC (vertical)
CODE	6060400

VERSION	HP-ECM
CODE	6060400

BSO-C extension condensate collection tray to cover valve assembly
(for horizontal units)

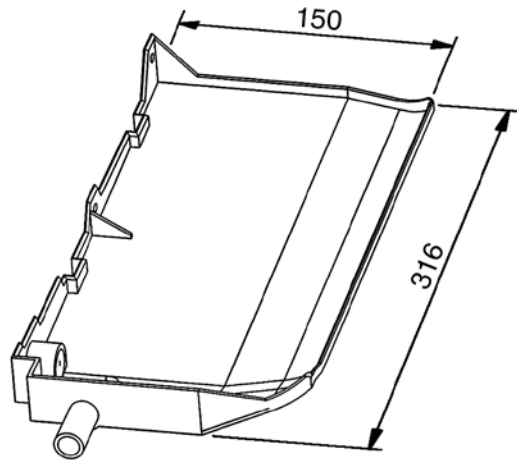

VERSION	SEC-ECM	
MODEL	CH (horizontal)	
CONNECTION SIDE	LEFT	RIGHT
TYPE	BSO-SX	BSO-DX
CODE	6060402	6060403

BSI-C extension condensate collection tray to cover valve assembly
(for horizontal units)

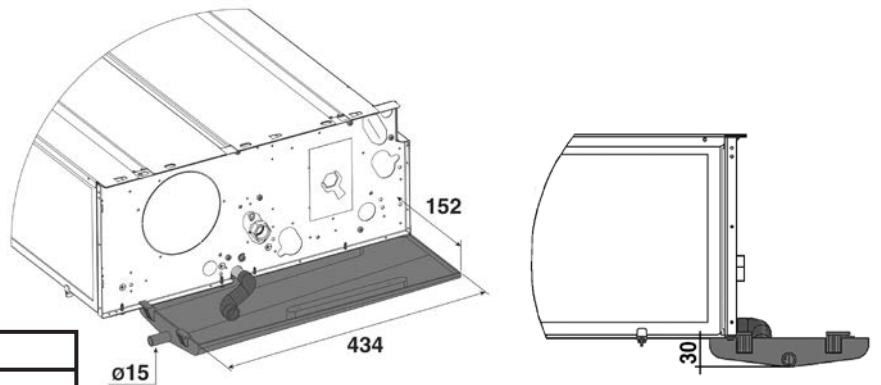

VERSION	SEC-ECM
MODEL	NC (horizontal)
CODE	6066039

VERSION	HP-ECM
CODE	6066039

Not to be used with KAF.

DRPV-C fitted condensate pump
(for vertical units)



VERSION	SEC-ECM	HP-ECM
MODEL	CV - CVB - NC (vertical)	

	FITTED	NOT FITTED
TYPE	DRPV-C-M	DRPV-C-S
CODE	9066297	9066296

HEIGHT FOR VERTICAL FLOW (m)	WATER FLOW (l/h) DEPENDING ON THE LENGTH OF HORIZONTAL FLOW	
	5 m	10 m
1	7,6	7,2
2	5,6	5,2
3	4,0	3,7
4	3,2	2,9

DRPO-C fitted condensate pump
(for horizontal units)

VERSION	SEC-ECM
MODEL	CV (horizontal)
CODE	9066295

HEIGHT FOR VERTICAL FLOW (m)	WATER FLOW (l/h) DEPENDING ON THE LENGTH OF HORIZONTAL FLOW	
	5 m	10 m
1	7,6	7,2
2	5,6	5,2
3	4,0	3,7
4	3,2	2,9

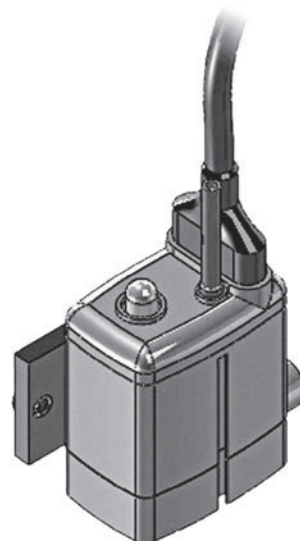

DRPI-C fitted condensate pump
(for horizontal units)

VERSION	SEC-ECM
MODEL	NC (horizontal)
CODE	9066180

VERSION	HP-ECM
CODE	9066180

HEIGHT FOR VERTICAL FLOW (m)	WATER FLOW (l/h) DEPENDING ON THE LENGTH OF HORIZONTAL FLOW	
	5 m	10 m
1	7,6	7,2
2	5,6	5,2
3	4,0	3,7
4	3,2	2,9



SCR plastic condensate drain pipe with fast connection
(allows correct condensate drain)

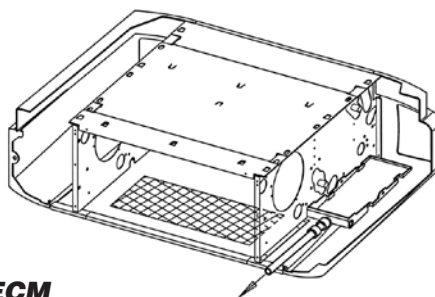

SEC-ECM

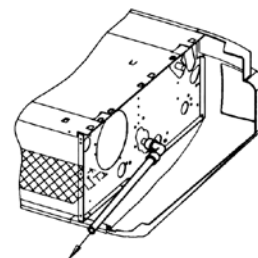

HP-ECM

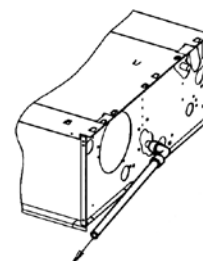
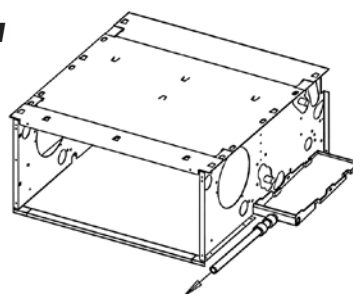

VERSION	SEC-ECM	HP-ECM
MODEL	CH - NC	
CODE	6060420	

PAP feet

VERSION	SEC-ECM
MODEL	CV

SIZE	L	CODE
2	430	9060150
4	645	9060150
6	860	9060150
7	1119	9060150
9	1119	9060151

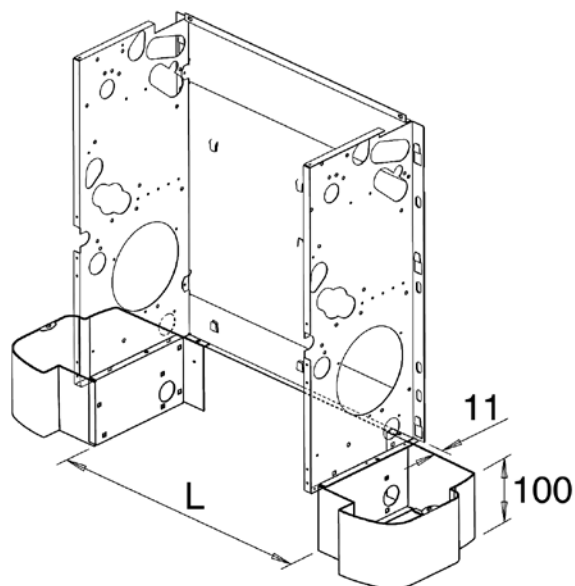

GAP

Aluminium low intake grid
(to be installed with PAP feet)

VERSION	SEC-ECM
MODEL	CV

SIZE	CODE
2	9066542
4	9066543
6	9066545
7 - 9	9066547

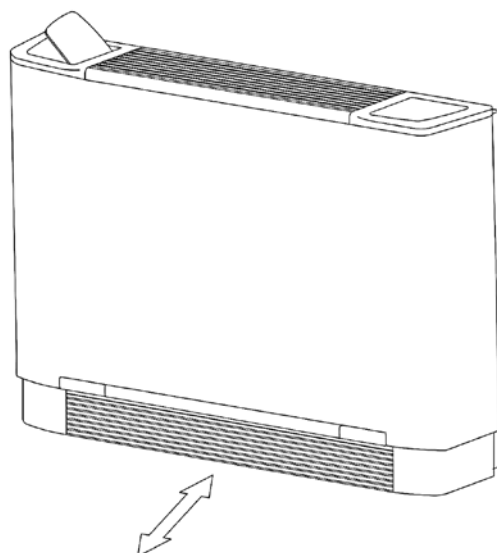

KAF frontal intake kit

Bottom closing panel and filter sliding guides.

VERSION	SEC-ECM
MODEL	NC

SIZE	CODE
2	9066502
4	9066503
6	9066505
7	9066507
9	9066508

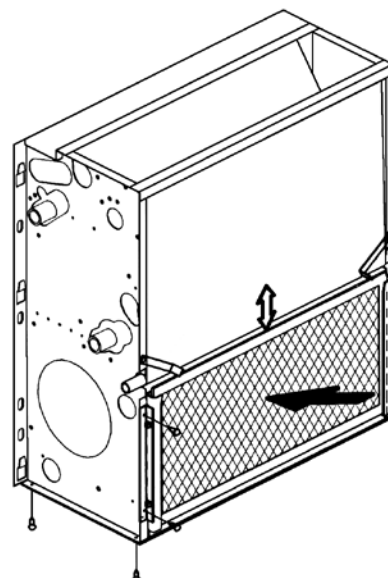

Not to be used with **BSI-C**.

PCVL rear closing panel (for vertical units)

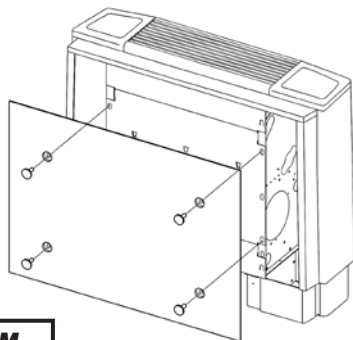

VERSION	SEC-ECM
MODEL	CV - CVB

SIZE	CODE
2	9070140
4	9070141
6	9070142
7 - 9	9070143

PCOL bottom closing panel (for horizontal units)

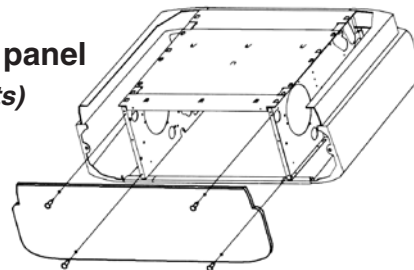

VERSION	SEC-ECM
MODEL	CH

SIZE	CODE
2	9070220
4	9070221
6	9070222
7	9070223
9	9070224

SAEM fresh air mixing damper (factory mounted with feet and intake grid included, MV only)

(can not be motorized)

VERSION	SEC-ECM
MODEL	CV

SIZE	A	B	L	CODE
2	186	78	454	9076332
4	186	78	669	9076333
6	186	78	884	9076335
7	186	78	1099	9076337
9	216	108	1099	9076338

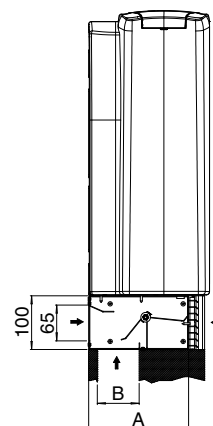
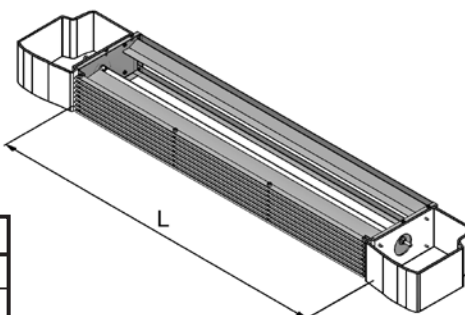

SAE fresh air mixing damper (not mounted, IV - IO only)

(can not be motorized)

VERSION	SEC-ECM
MODEL	NC

SIZE	A	B	L	CODE
2	186	78	454	9066532
4	186	78	669	9066533
6	186	78	884	9066535
7	186	78	1099	9066537
9	216	108	1099	9066538

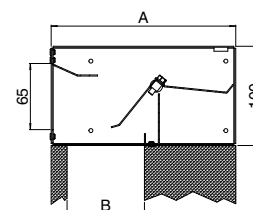
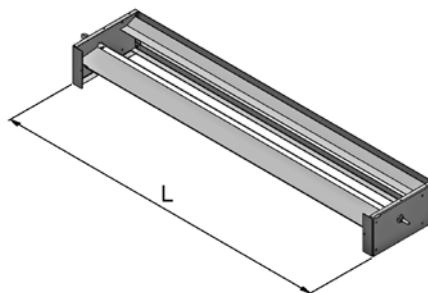

FRD straight inlet flange

Can be used together with GRAG air inlet grid.
Made of galvanized steel.

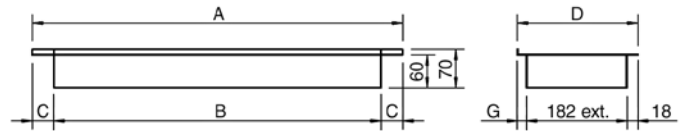

VERSION	SEC-ECM	HP-ECM
MODEL	NC	

SIZE								
SEC	HP	TYPE	A	B	C	D	G	CODE
2	-	FRD - 2	454	390	32	216	16	9060720
4	1	FRD - 3/4	669	590	39,5	216	16	9060721
6	-	FRD - 5/6	884	790	47	216	16	9060722
-	2	FRD - 4S	884	790	47	246	46	9038002
7	-	FRD - 7	1099	990	54,5	216	16	9060723
9	3	FRD - 8/9	1099	990	54,5	246	46	9060724

FR 90 90° inlet flange

Can be used together with GRAP air inlet grid.
Made of galvanized steel.

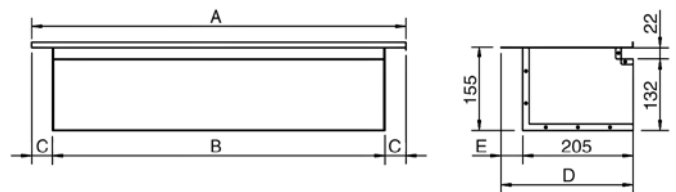

VERSION	SEC-ECM	HP-ECM
MODEL	NC	

SIZE								
SEC	HP	TYPE	A	B	C	D	E	CODE
2	-	FR90 - 2	454	390	32	216	11	9060710
4	1	FR90 - 3/4	669	590	39,5	216	11	9060711
6	-	FR90 - 5/6	884	790	47	216	11	9060712
-	2	FR90 - 4S	884	790	47	246	41	9038001
7	-	FR90 - 7	1099	990	54,5	216	11	9060713
9	3	FR90 - 8/9	1099	990	54,5	246	41	9060714

GRAP air inlet grid

To be used with FR 90 90° inlet flange.
Made of anodized aluminium.

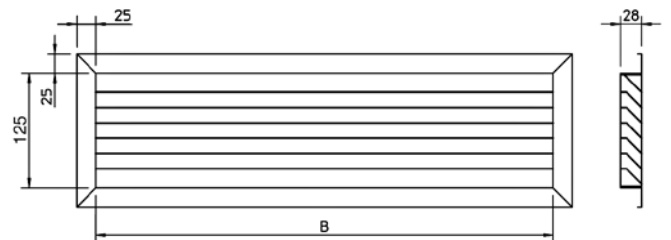

VERSION	SEC-ECM	HP-ECM
MODEL	NC	

SIZE					
SEC	HP	TYPE	DESCRIPTION	B	CODE
2	-	GRAP - 2	Grid 400x150	375	9060760
4	1	GRAP - 3/4	Grid 600x150	575	9060761
6	2	GRAP - 5/6	Grid 800x150	775	9060762
7 - 9	3	GRAP - 7/9	Grid 1000x150	975	9060763

GRAG air inlet grid

To be used with FRD straight inlet flange.
Made of anodized aluminium.

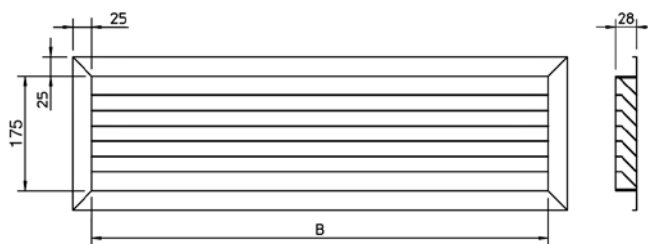

VERSION	SEC-ECM	HP-ECM
MODEL	NC	

SIZE					
SEC	HP	TYPE	DESCRIPTION	B	CODE
2	-	GRAG - 2	Grid 400x200	375	9060764
4	1	GRAG - 3/4	Grid 600x200	575	9060765
6	2	GRAG - 5/6	Grid 800x200	775	9060766
7 - 9	3	GRAG - 7/9	Grid 1000x200	975	9060767

FRC fresh air connection

(not mounted)

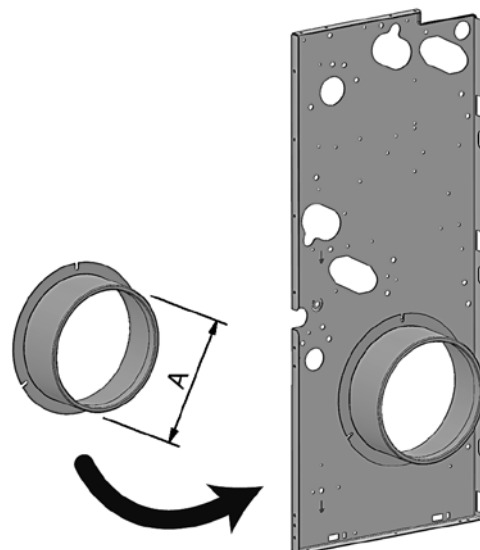

VERSION	SEC-ECM
MODEL	NC

SIZE	TYPE	A	CODE
2 ÷ 9	FRC 100	98	6064191
2 ÷ 9	FRC 120	122	6064192

FMD straight outlet flange

Made of galvanized steel.

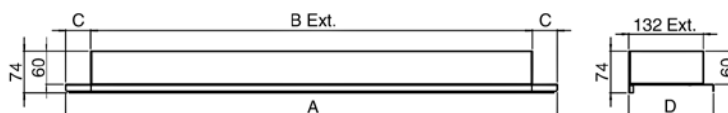

VERSION	SEC-ECM	HP-ECM
MODEL	NC	

SIZE							
SEC	HP	TYPE	A	B	C	D	CODE
2	-	FMD - 2	452	390	31	152	9066372
4	1	FMD - 3/4	667	590	38,5	152	9066373
6	-	FMD - 5/6	882	790	46	152	9066375
-	2	FMD - 4S	882	790	46	179	9069232
7	-	FMD - 7	1097	990	53,5	152	9066377
9	3	FMD - 8/9	1097	990	53,5	179	9066378

FM 90 90° outlet flange

Made of galvanized steel insulated with polyethylene lining.

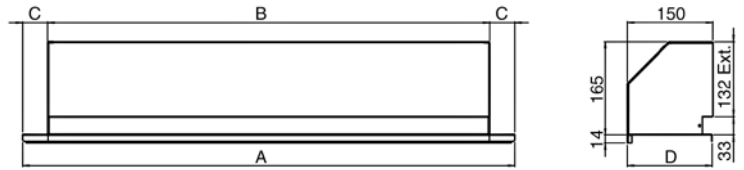

VERSION	SEC-ECM	HP-ECM
MODEL	NC	

SIZE								
SEC	HP	TYPE	A	B	C	D	CODE	
2	-	FM90 - 2	452	390	31	152	9066382	
4	1	FM90 - 3/4	667	590	38,5	152	9066383	
6	-	FM90 - 5/6	882	790	46	152	9066385	
-	2	FM90 - 4S	882	790	46	179	9060242	
7	-	FM90 - 7	1097	990	53,5	152	9066387	
9	3	FM90 - 8/9	1097	990	53,5	179	9066388	

BMA air outlet grid

Double louvre grid to be fitted to the duct, to the FMD straight outlet flange or to the FM 90 90° outlet flange. Made of anodized aluminium.

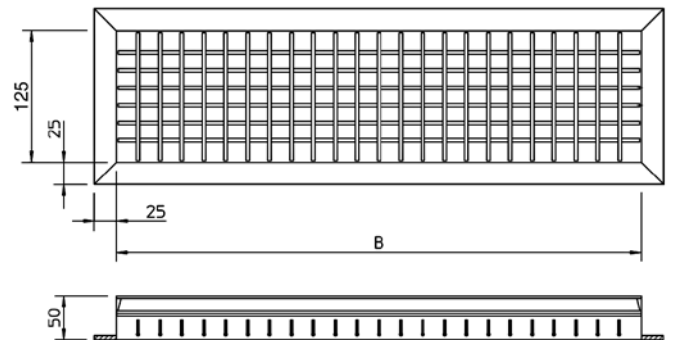

VERSION	SEC-ECM	HP-ECM
MODEL	NC	

SIZE				
SEC	HP	TYPE	B	CODE
2	-	BMA - 2	375	9060750
4	1	BMA - 3/4	575	9060751
6	2	BMA - 5/6	775	9060752
7 - 9	3	BMA - 7/9	975	9060753

PRC air inlet spigot plenum

Made of galvanized steel insulated with polyethylene lining.

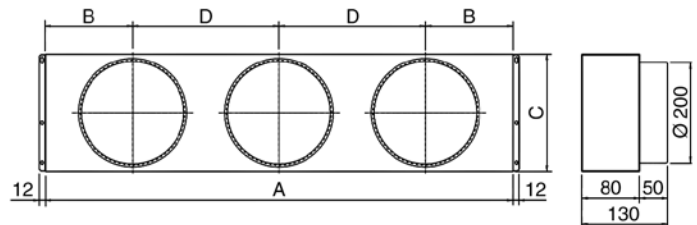

VERSION	SEC-ECM	HP-ECM
MODEL	NC	

SIZE									
SEC	HP	TYPE	A	B	C	D	SPIGOTS	CODE	
2	-	PRC - 2	430	107	218	216	N° 2	9066462	
4	1	PRC - 3/4	645	166	218	313	N° 2	9066463	
6	-	PRC - 5/6	860	160	218	270	N° 3	9066465	
-	2	PRC - 4S	860	160	248	270	N° 3	9038050	
7	-	PRC - 7	1075	190	218	347,5	N° 3	9066467	
9	3	PRC - 8/9	1075	190	248	347,5	N° 3	9066468	

All the plenums are supplied with spigots for the connection of flexible ducts.

PMC spigot diffuser

Made of galvanized steel insulated with polyethylene lining.

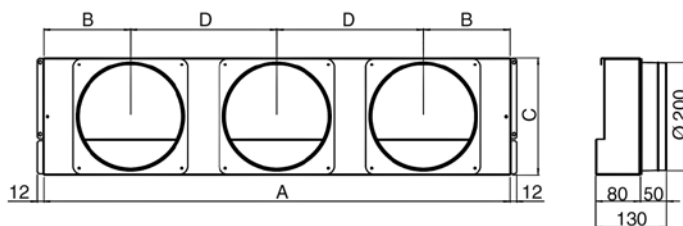

All the plenums are supplied with spigots for the connection of flexible ducts.

VERSION	SEC-ECM	HP-ECM
MODEL	NC	

SIZE		TYPE	A	B	C	D	SPIGOTS	CODE
SEC	HP							
2	-	PMC - 2	430	107	218	216	N° 2	9066362
4	1	PMC - 3/4	645	166	218	313	N° 2	9066363
6	-	PMC - 5/6	860	160	218	270	N° 3	9066365
-	2	PMC - 4S	860	160	248	270	N° 3	9069222
7	-	PMC - 7	1075	190	218	347,5	N° 3	9066367
9	3	PMC - 8/9	1075	190	248	347,5	N° 3	9066368

GRAFP air inlet grid with filter

To be fitted to the FR 90 90° inlet flange. Made of anodized aluminium.

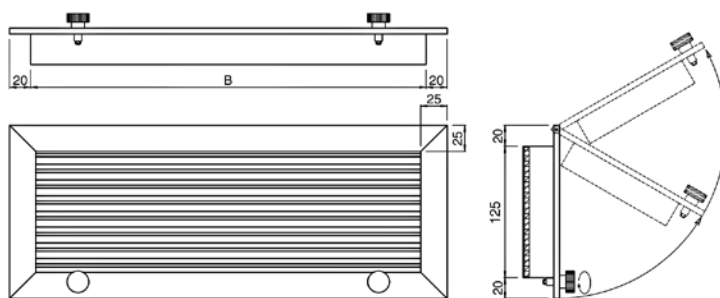

VERSION	SEC-ECM
MODEL	NC

SIZE	TYPE	B	CODE
2	GRAFP - 2	375	9060770
4	GRAFP - 3/4	575	9060771
6	GRAFP - 5/6	775	9060772
7 - 9	GRAFP - 7/9	975	9060773

GRAFG air inlet grid with filter

To be fitted to the FRD straight inlet flange. Made of anodized aluminium.

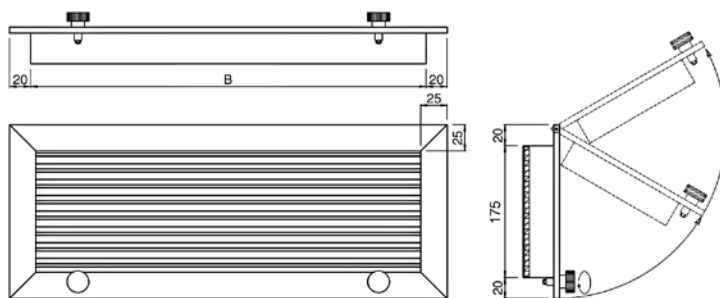

VERSION	SEC-ECM
MODEL	NC

SIZE	TYPE	B	CODE
2	GRAFG - 2	375	9060774
4	GRAFG - 3/4	575	9060775
6	GRAFG - 5/6	775	9060776
7 - 9	GRAFG - 7/9	975	9060777

CHK Hotel fan kit

Hotel box for concealed installation for Carisma SEC-ECM, NC model (frontal return and supply).

The new CHK kit is the best solution for all installations requiring a built-in fan coil where there is no other possibility of accessing the unit except from the air outlet side. The unit is particularly suitable for installation in hotel rooms, offices and homes.

The Kit consists of a box that can easily be installed in a false ceiling, inside which the fan coil is fitted using the special guides. For simply remove the front outlet and access the air filter as well as the electrical and hydraulic parts of the unit.

The air grid is divided into two zones, one for the air intake with horizontally adjustable fins and the other one for the air outlet with horizontally and vertically adjustable fins to ensure better air distribution and diffusion in the room.

The box structure is made of thick galvanised metal sheet.

The internal air flow sections are insulated with expanded polyethylene that prevents both condensation and energy loss towards the inside of the false ceiling.

The accessory includes the air filter, an anodised aluminium outlet with adjustable fins and a front wall frame.

The box structure is designed so that fan coils with hydraulic connections facing left or right can be installed. According to the configuration, it is in fact sufficient to secure the sliding guides on the panel that will be the upper one.



When ordering, it must be specified that the fan coil hydraulic and electrical connections must be on the same side.

Note: consider 20 Pa pressure drop.

VERSION	SEC-ECM
MODEL	NC

SIZE	TYPE	A	CODE
4	CHK 3-4	1060	9066783
6	CHK 5-6	1316	9066785
7	CHK 7	1610	9066787

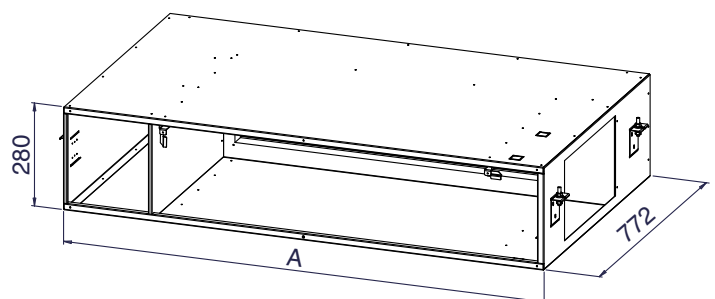

BXS silencers plenum

Sound attenuator module

Made of galvanised steel metal sheet, lined internally with a reinforced glass wool mat on both sides with a black glass coating; the 50 mm and 30 kg/m³ density lining ensures high noise reduction with very low pressure drops.

Sound attenuation levels

FREQUENCY	Hz	125	250	500	1000	2000	4000	8000
SOUND ATTENUATION	dB	2.5	5.0	11.5	14.0	13.5	12.0	11.0

Note: the silencer plenum reduces the sound levels only on the supply side; the sound levels on the return side are not affected by the silencer.

VERSION	SEC-ECM	HP-ECM
MODEL	NC	

SIZE						
SEC	HP	TYPE	L	L1	A	CODE
4	1	BXS-A	675	597	653	9069081
6	2	BXS-B	890	812	868	9069082
7	3	BXS-C	1105	1027	1083	9069083

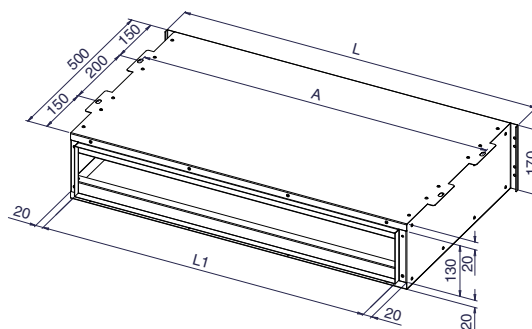

Silencer plenum pressure drop

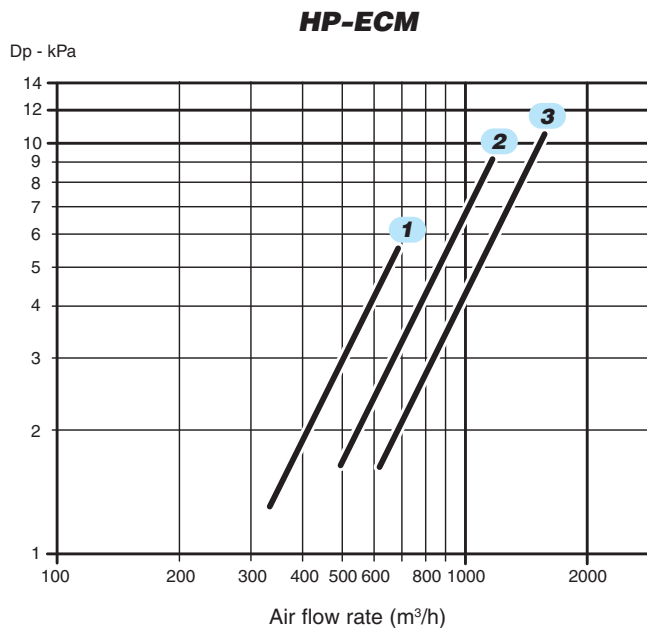
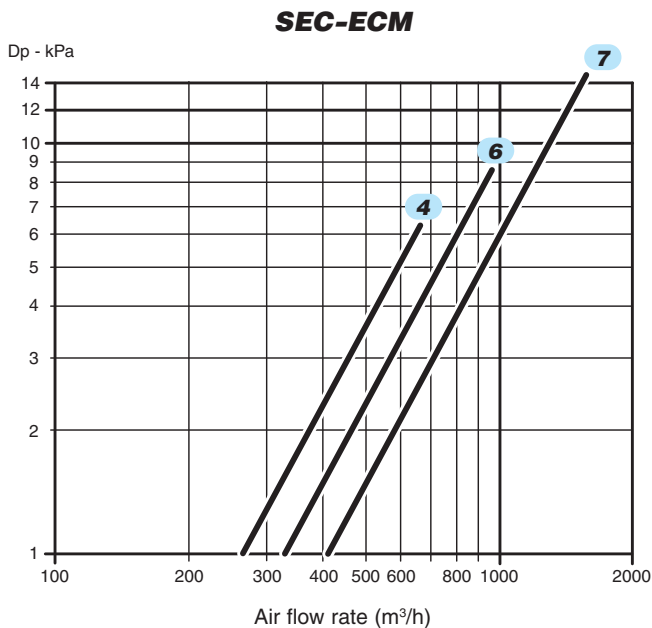

SEC-ECM / HP-ECM configuration

For this fan coil configuration, the 1-10 Vdc signal, which controls the inverter, must be supplied by a controller with the following signal specifications:

Fan coil control signal

- 0 Vdc = Fan OFF
- >1 Vdc = Fan ON
- 10 Vdc = Maximum speed

ECM Blac board

0÷10 Vdc Circuit Input Impedance Value= 68kOhm

SEC-ECM / HP-ECM electric wiring diagram

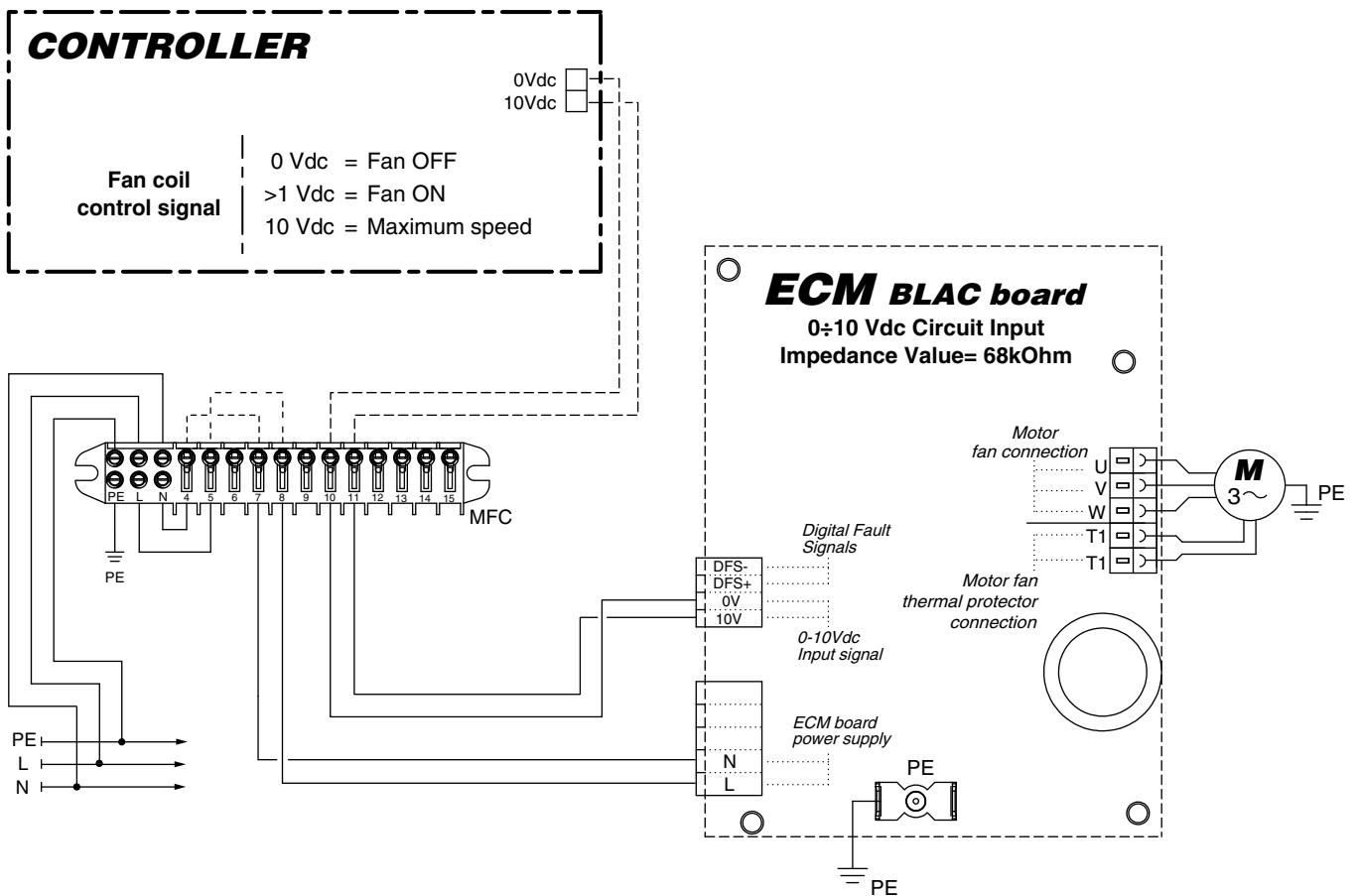

LEGEND:

BLAC = Inverter circuit board **M** = Electronic motor **CONTROLLER** = Controller

Electronic control to be fitted – SEC-ECM version

IDENTIFICATION	CODE
TMV-T-ECM	9060141

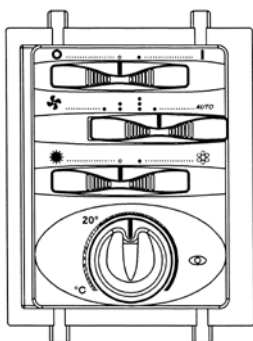

- ON-OFF switch.
- Manual 3 speed switch or automatic continuous speed control.
- Manual Summer/Winter switch.
- Continuous speed control based on the difference between ambient temperature and Set temperature (speed switch in Auto position).
- Electronic room thermostat for fan or valve control (ON-OFF).
- Simultaneous thermostatic control of the valves and fan.
- It allows to control low temperature cut-out (NTC).

Control power absorption: 1,5 VA

Electronic control to be fitted – SEC-ECM version with electric heater

IDENTIFICATION	CODE
TMV-T-ECM-IAQ	9060141

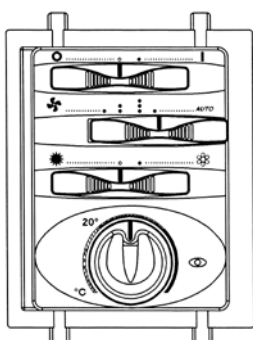

- Manual 3 speed switch or automatic continuous speed control.
- Manual, automatic or centralized Summer/Winter switch.
- Continuous speed control based on the difference between ambient temperature and Set temperature (speed switch in Auto position).
- Electric heater activation button.
- Automatic speed switch: on Auto Mode there is the automatic speed selection in accordance to the difference between room temperature and setpoint. When the setpoint is reached the fan goes on OFF.
- Electronic room thermostat for fan control (ON-OFF).
- Electronic room thermostat for valve control (ON-OFF) (the fan keeps working).
- Simultaneous thermostatic control of the valves and fan.
- It allows to control the temperature cut-out (NTC).

Control power absorption: 1,5 VA

Wall electronic controls – SEC-ECM / HP-ECM version

IDENTIFICATION	CODE
WM-AU	9066632E



Dimensions: 135x86x24 mm

The control must always be connected with UP-AU power unit (fitted on the unit) or with UP-AU power unit (not fitted on the unit).

- ON-OFF switch.
- Manual, automatic or centralized Summer/Winter switch.
- Manual or automatic 3 speed progressive switch.
- Summer/Winter/Fan/Auto mode switch.
- Electric heater / IAQ filter activation switch.
- Electronic room thermostat for fan control (ON-OFF).
- Electronic room thermostat for valve control (ON-OFF).
- Simultaneous thermostatic control of the valves and fan.
- It allows to control the low temperature cut-out thermostat (NTC) mounted on the UP-AU power unit.
- It allows to control the water valves (ON-OFF) and the electric heater managed as main heating element or as an integration element.
- Energy saving switch.
- Presence of a LED signal when the thermostat is on.

N.B.: with 4 pipe installations and continuous chilled and hot water supply, it allows the automatic summer winter change-over in accordance to the room temperature (-1°C = Winter, +1°C = Summer, Neutral Zone 2°C).

Control power absorption: see the UP-AU power unit

IDENTIFICATION	CODE
T-MB	90666331E



Dimensions: 110x72x25 mm

The control must always be connected with UP-AU power unit (fitted on the unit) or with UP-AU power unit (not fitted on the unit).

Wall control with display that allows controlling one or more units in Master/Slave mode. The control is equipped with internal sensor to detect the room temperature, which can be defined as a priority compared to the return air sensor on the fan coil.

The T-MB control features the following functions:

- Switch the unit ON and OFF.
- Temperature set.
- Manual, centralized or automatic Summer/Winter switch.
- Set the fan speed (low, medium, high or autofan).
- Set the operation mode (fan only, cooling, heating; auto for 4 pipe systems with mode selection depending on the air temperature).
- Possibility of use of the low temperature cut-out thermostat NTC mounted on the UP-AU power unit.
- It allows to control the water valves (ON-OFF) and the electric heater managed as main heating element or as an integration element.
- Time setting.
- Weekly ON/OFF program.

Control power absorption: see the UP-AU power unit

DESCRIPTION	IDENTIFICATION	CODE
Power unit for WM-AU and T-MB remote control (fitted on the unit)	UPM-AU	9066641
Power unit for WM-AU and T-MB remote control (not fitted on the unit)	UP-AU	9066640



Power unit to be installed on the fan coil (fan coil interface).

- It controls the fan and the valves of the fan coil.
- It is connected to the electric supply.
- It receives the information required from the control.
- Possibility to use the low temperature cut-out thermostat (optional) for the T1 function which allows the return air control.
- Possibility to use the low temperature cut-out thermostat (optional) for the T2 function which controls the summer/winter switch.
- Possibility to use the low temperature cut-out thermostat (optional) for the T3 function as low temperature cut-out thermostat.
- It allows to control up to 10 units (1 master and 9 slaves).
- Max. Network length: 100 meters.
- Max cable length between control and first connected power unit: 20 meters.

Control power absorption: 2,3 VA

Wall electronic controls – SEC-ECM / HP-ECM version

IDENTIFICATION

CODE

WM-S-ECM

9066644



Dimensions: 132x87x23,6 mm

0-10V control with display designed to be mounted on the wall or to be installed on a 503 wall box.

- ON-OFF switch.
- Manual 3 speed switch or automatic continuous speed control.
- Manual Summer/Winter switch.
- Summer/Winter/Fan/Auto mode switch.
- Electronic room thermostat for fan control (ON-OFF).
- Electronic room thermostat for valve control (ON-OFF).
- Simultaneous thermostatic control of the valves and fan.
- It allows to control the low temperature cut-out thermostat (NTC).

Control power absorption: 1,2 VA

Electronic control accessories

NTC low temperature cut-out thermostat

To be fitted between the coil fins; when connecting the control, the NTC probe cable must be separated from the power supply wires.

To be used with the **TMV-T-ECM**, **TMV-T-ECM-IAQ**, **WM-S-ECM** controls and the **UP-AU** power unit.

It stops the fan when the water temperature is lower than 28°C and it starts the fan when is higher than 33°C.

To use as:

- T1 function for the return air control.
- T2 function which controls the summer/winter switch.
- T3 function as low temperature cut-out thermostat.

SÉRIE	SEC-ECM	HP-ECM
VERSION	CV - CH - CVB - NC	
CODE	3021090	



Change-Over CH 15-25

Automatic summer/winter switch to be installed in contact with the water circuit.

For 2 tube installations only (not to be used with 2 way valve).

To be used with the **TMV-T-ECM-IAQ** control.

SÉRIE	SEC-ECM
VERSION	CV - CH - CVB - NC
CODE	9053049



T2 sensor to be placed on the water supply pipe upstream 3 way valves (not to be used with 2 way valve).

The T2 sensor must be used as described below:

- Change-Over for the automatic switch of the operating mode.
If water temperature is lower than 20°C, cooling mode is set; on the other hand, if water temperature exceeds 30°C, heating mode is set.
- It can be used on units with electric heater and hot water supply. The T2 priority probe activates the electric heater or water valve, depending on the water temperature detected. If water temperature exceeds 34°C, the water valve ON-OFF control is activated; on the other hand, if water temperature is lower than 30°C, the electric heater is activated.

To be used with the **UP-AU** power unit.

SÉRIE	SEC-ECM	HP-ECM
VERSION	CV - CH - CVB - NC	
CODE	9025310	

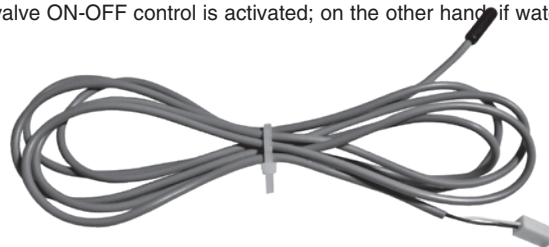

Controls and units **MB** version

All the **SEC-ECM** and **HP-ECM** units can be supplied with a wide range of controls, which allows managing one single unit or several units by using the Modbus RTU - RS 485 communication protocol. Units can be managed according to the Master/Slave logic (up to 20 units) or by supervisory components. The system consists in a **MB** board and a series of controls, such as the **T-MB** control, the **RT03** infra-red remote control, the **PSM-DI** multi-function control and the **NET** supervisory program.

MB electronic board

DESCRIPTION	IDENTIFICATION	CODE
<i>MB electronic board fitted on the unit</i>	<i>MB-ECM-M</i>	<i>9066334</i>
<i>MB electronic board supplied with separate packaging</i>	<i>MB-ECM-S</i>	<i>9066335</i>

The **MB** electronic board, to be mounted on the fan coil internal unit, is set to carry out different functions and adjustment modes, in order to meet the installation requirements. These modes are selected by setting the configuration dip switches on the board.

- 2/4 pipe system.
- Fan ON/OFF thermostatic control.
- Valve ON/OFF thermostatic control and continuous ventilation.
- Valve and simultaneous ventilation ON/OFF thermostatic control.
- Fan operation control depending on the coil temperature (cut-out T3 probe fitted), which can be activated only in heating mode or heating and cooling mode.
- Automatic switch of the operating mode by means of T2 water probe (optional) applied on the 2 pipe system.
- Seasonal switch by means of remote contact.
- ON/OFF of the fan coil by means of the remote contact (window or clock contact).
- Electric heater control.

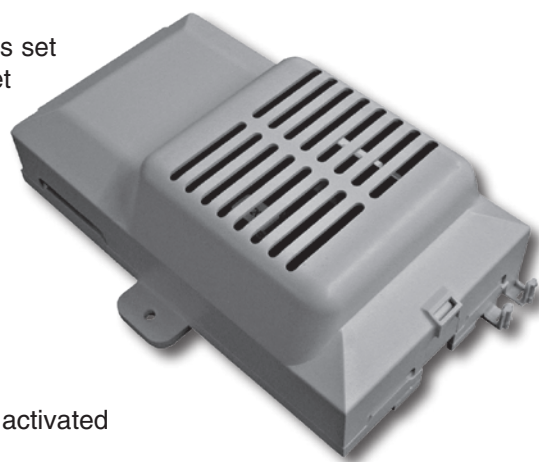

By activating the cut-out T3 probe function, the fan is stopped in winter when the coil temperature is lower than 32°C and started when the temperature reaches 36°C. In summer mode, the fan stops when the temperature inside the coil exceeds 22°C and starts when it drops below 18°C.

The following connections are located on the power board:

- Receiver for infra-red remote control.
- T-MB control.
- RS 485 serial connection to manage several fan coils in Master/Slave configuration or to create a supervisory network.

NTC sensor included for T1 function (return air control).

NTC sensor included for T3 function (low temperature cut-out thermostat).

NTC sensor (option) for T2 function (summer/winter switch).

Controls and units **MB** version

T-MB control

DESCRIPTION	IDENTIFICATION	CODE
Wall control (to be used with MB board only)	T-MB	9066331E
Control fitted on the unit, for CV / CVB models (to be used with MB board only) - SEC-ECM only	T-MB-LM	9066646
Control supplied with separate packaging, for CV / CVB models (to be used with MB board only) - SEC-ECM only	T-MB-LS	9066645
Control fitted on the unit, for CV / CVB models (to be used with JP-AU power unit only) - SEC-ECM only	T-MB-M-UP	9066675
Control supplied with separate packaging, for CV / CVB models (to be used with JP-AU power unit only) - SEC-ECM only	T-MB-S-UP	9066674

Control with display that allows controlling one or more units in Master/Slave mode. The control is equipped with internal sensor to detect the room temperature, which can be defined as a priority compared to the return air sensor on the fan coil.

The **T-MB** control features the following functions:

- Switch the appliance ON and OFF.
- Temperature set.
- Modify the set point (when used as a +/- 3° variation of the set point configured from NET supervisory program or PSM-DI).
- Set the fan speed (low, medium, high or autofan).
- Set the operation mode (fan only, cooling, heating; auto for 4 pipe systems with mode selection depending on the air temperature).
- Time setting.
- Weekly ON/OFF program.
- Display and change of the fan coil operation parameters.



Dimensions: 110x72x25 mm

Controls and units MB version

RT03 infra-red remote control

DESCRIPTION	IDENTIFICATION	CODE
<i>RT03 infra-red remote control with fitted receiver, for CV-CH-CVB models (to be used with MB board only) - SEC-ECM only</i>	RM-RT03	9066336
<i>RT03 infra-red remote control with receiver supplied with separate packaging (to be used with MB board only)</i>	RS-RT03	9066337
<i>RT03 infra-red remote control supplied with separate packaging (to be used with MB board only)</i>	RT03	3021203
<i>Receiver for RT03 infra-red remote control fitted on the unit, for CV-CH-CVB models (to be used with MB board only) - SEC-ECM only</i>	RM	9066339
<i>Receiver for RT03 infra-red remote control supplied with separate packaging (to be used with MB board only)</i>	RS	9066338

The infra-red remote control allows setting by a remote position the fan coil operation parameters.

The **RT03** infra-red remote control features the following functions:

- Switch the appliance ON and OFF.
- Temperature set.
- Set the fan speed (low, medium, high or autofan).
- Set the operation mode (fan only, cooling, heating; auto for 4 pipe systems with mode selection depending on the air temperature).
- Time setting.
- 24 hours ON/OFF program.



**INSTALLATION EXAMPLE
WITH INFRA-RED REMOTE CONTROL**

Controls and units **MB** version

A group of **SEC-ECM** and **HP-ECM** units with **MB** electronic board can be connected via a serial link and can consequently be managed at the same time by just one **T-MB** control or **RT03** infra-red remote control. Using the special jumper present on the **MB** board, one unit must be configured as the master, and all the others as slaves. It is clear that the remote control must be pointed at the receiver on the master unit. To avoid problems, it is recommended to install and connect the receiver only on the master unit.

With T-MB control

One control for each unit

(MAXIMUM LENGTH OF THE CONNECTION CABLE = 20 m)



One control for more units (20 units max.)

(MAXIMUM TOTAL LENGTH OF THE CONNECTION CABLE = 800 m)

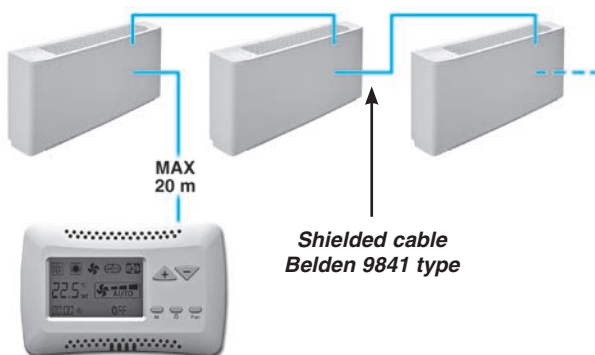

With RT03 infra-red remote control

One control for each unit



One control for more units (20 units max.)

(MAXIMUM TOTAL LENGTH OF THE CONNECTION CABLE = 800 m)

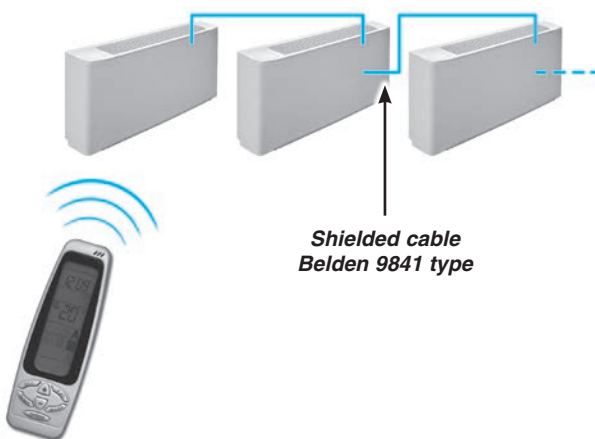

T2 accessory for units with MB electronic board

IDENTIFICATION	CODE
T2	9025310

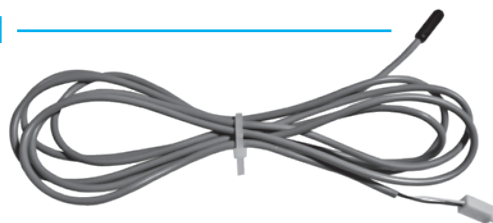

The T2 sensor can be combined with MB boards to be placed on the water supply pipe upstream 3 way valves (not to be used with 2 way valve).

The T2 sensor must be used as described below:

- Change-Over for 2-pipe system for the automatic switch of the operating mode.
If water temperature is lower than 20°C, cooling mode is set; on the other hand, if water temperature exceeds 30°C, heating mode is set.
- It can be used on units with electric heater and hot water supply. The T2 priority probe activates the electric heater or water valve, depending on the water temperature detected. If water temperature exceeds 34°C, the water valve ON-OFF control is activated; on the other hand, if water temperature is lower than 30°C, the electric heater is activated.

Controls and units MB version

PSM-DI multifunction control panel

DESCRIPTION	IDENTIFICATION	CODE
Multifunction control (to be used with MB board only)	PSM-DI	3021293

Another option available for the serial communication between the units is the possibility to connect up to 60 **SEC-ECM** and **HP-ECM** units in series and manage them with just one wall mounted **PSM-DI** controller. The wall mounted controller can be used to set the operating mode for each individual unit connected, display the operating conditions of each individual unit, and set the ON/OFF time sets for each day of the week (the program can be set for all the units and for a maximum of ten groups of units).

If more than 60 units need to be connected, two or more control panels must be used. Each unit must have a MB board. The **PSM-DI** control is used to manage a series of fan coils, up to a maximum of 60 units (the maximum length of the RS 485 connection cable must not exceed 800 m), from one single control point.

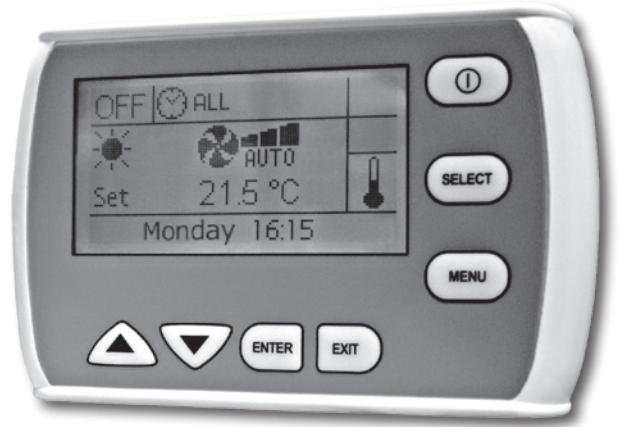

The **PSM-DI** control communicates via a serial line with all the units connected, with the possibility of controlling them all together or individually. In fact, the unique address of each individual fan coil means that all the units can be called at the same time, or the individual unit called, to perform the following functions:

- display the current operating mode, the fan speed, the set point;
- display the room temperature measured on the individual unit;
- turn all the units ON and OFF at the same time or alternatively each unit individually;
- change the operating mode (fan only, heating, cooling, automatic changeover);
- change the set point;
- modify the values and operation parameters of the fan speed.

Each function can then be sent to all the units connected, or alternatively to each individual unit.

Different set points or operating modes can be set for each individual unit.

The **PSM-DI** panel can also be used for the time management of the units over the week. Four ON times and four OFF times can be set on the units for each day of the week. A different temperature set that will be considered as Operation set for all connected appliances, can be set for each event. If the temperature set is not entered for the individual event, it must be set during programming for each individual unit or for the entire network.

Units without receiver or with receiver can be connected within the network: the former can receive instructions only from the **PSM-DI** wall mounted panel; while the latter can receive information from both the wall mounted panel (**PSM-DI**) and infra-red remote control. Use the infra-red remote control to force ON mode of the individual unit, if ON/OFF daily time programming has been set. The unit will regain the settings from the **PSM-DI** panel during execution of successive start-up program.

The PSM-DI panel cannot be used together with the NET management program (see next page).

Notes:

- set the Dip Switches of each fan coil as illustrated in the remote control installation manual, based on the required solutions.
- it is possible to connect only one single SIOS board per each PSM-DI control panel.
- about "Priority pump function": when just one unit calls for, the relay RL1 on the SIOS board is automatically activated to connect a hot water pump.
- the RS 485 network's overall length must not exceed 700/800 metres.

Management system for a network of fan coils

NET program for managing a network of MB fan coils

DESCRIPTION	IDENTIFICATION	CODE
Hardware/software supervisory system (to be used with MB board only)	NET	9079118

NET is a centralised control system for networks of MB fan coils, based on software that runs on LINUX™ operating system (the program is provided pre-installed on a PC) and it works in a “stand alone” way, as an ordinary computer, so that it can be connected to a monitor, to a mouse and to a keyboard. By connecting an Ethernet cable is instead possible to work at a distance and visualize the entire program setting-up through whatever browsers. The **NET** software offers a practical and economical solution for managing the units, with the simple click of the mouse.

The main characteristics include:

- simplicity of use;
- an extremely complete and functional weekly program;
- possibility to access the historical operating data for each individual unit connected;
- possibility to save automatically every 6 h the data on SD support and to force the saving with a key;
- possibility of data saving also on other items, as for example USB key;
- visualization of the saved configuration on a new ASUS PC.

The program exploits all the potential of our units with remote controls, representing an addition to the latter.

The **NET** program is a control tool that can be used as a replacement for the remote control, or in parallel, however the settings made using **NET** can have priority over those made using the remote control.

The program can be used to:

- Create uniform groups (groups of units on individual floors, in offices or rooms).
- Save weekly programs configured for different types of operation (summer, winter, mid seasons, closing periods etc.); these can then be recalled and activated with a simple click of the mouse. Weekly on/off cycles can be set for individual units or groups of units.
- Set the operating conditions for each individual unit or groups of units (operating mode, fan speed, temperature setting).
- Set the set point limits for each individual unit or groups of units.
- Switch each individual unit or groups of units ON or OFF.



Management system for a network of fan coils

The main program screen can display and interact with the entire network of units. An individual unit, a group of units or the entire network can be called so as to make modifications to the operating mode and the set point. The user can then check the operating status of each individual unit, read the room temperature, the coil temperature and the operating status of the condensate drain pump or any alarms.



Displaying a unit

The **“MONITORING” SCREEN** shows the units that are connected to the network and scanned by the program.

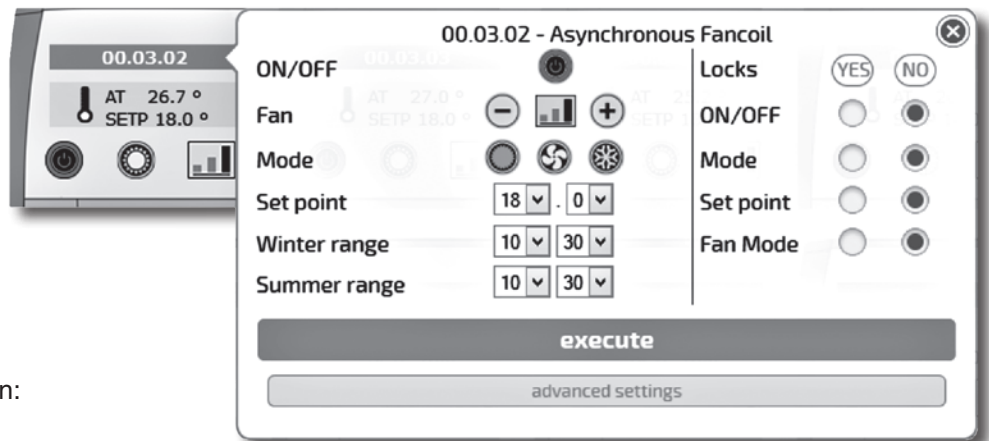

The icon of the terminal unit provides the following information:

- Unit name (**00.03.02**)
- Set temperature (SETP)
- Room temperature (AT)
- Unit status: ON (Green) or OFF (Red)
- Mode:
 - Summer
 - Winter
- Auto
- Fan only
- Fan speed:
 - Low
 - Medium
- High
- AutoFan

Management system for a network of fan coils

The “Weekly Program” can be used to set the unit operating parameters for each day of the week. Up to 20 different weekly programs can be set.

“EVENT MANAGEMENT” SCREEN

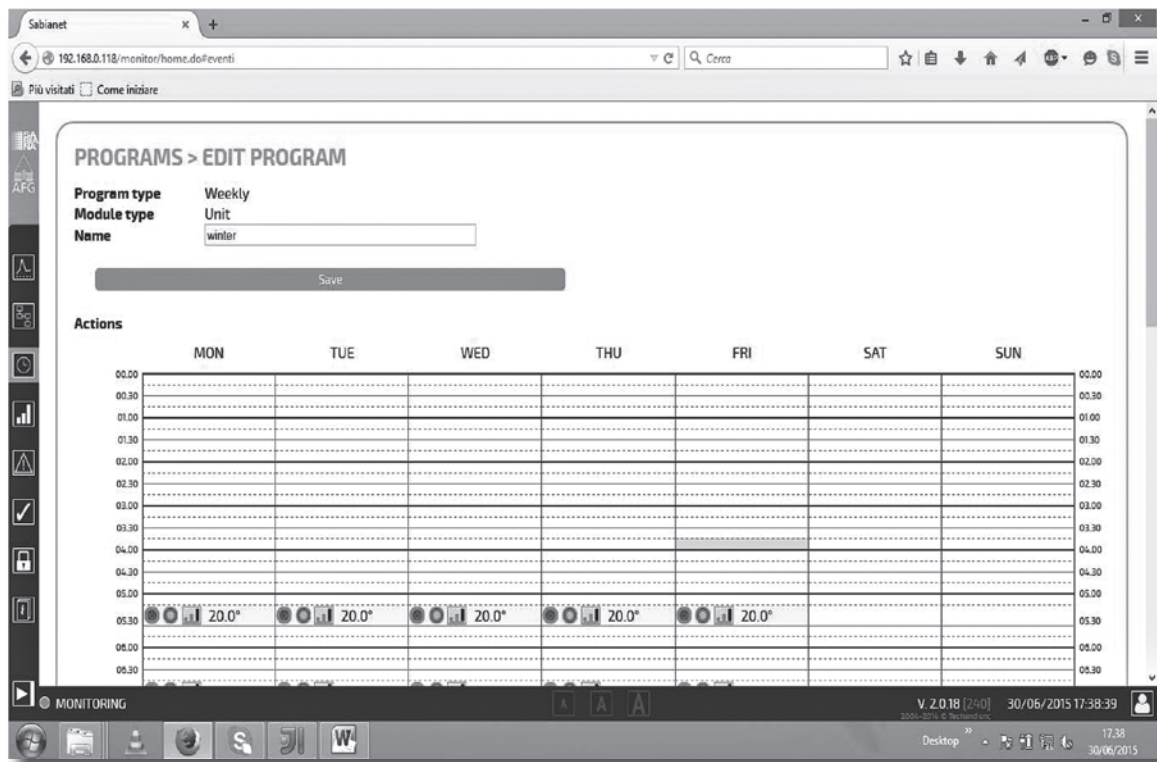

Time bands are available for each day of the week. The time and the type of operation to be performed by the unit can be set for each band. The time and the operating parameters can then be displayed before being sent to the unit and implemented.

Displaying of the parameters and Dip Switches set up

Every time that the reading of the set up Dip Switches results not easy (as for example by the false ceiling installations), it is always possible to display them directly through the NET program.

Group: gruppo 1	FW release: 0.50	Program: gruppo 1 inverno	
Remote control: N.A.	M/S network: N.A.	Unit tree: Level 2 --> Router 1	
Unit status: ON	Mode: WINTER	Fan mode: AUTO	Fan status: OFF
Set Point: 22.0°	Heating status: OFF	Cooling status: [OFF]	Inverter voltage: 0.2
T1: 22.5°	T2: N.A.	T3: 28.5°	
Pump: YES	Remote ON/OFF input: OFF	Window input: OFF	

Unit settings		Alarms
Dip Switch:	OFF ON	
<input type="checkbox"/> 1	2 pipe unit	T1 Fault OFF
<input type="checkbox"/> 2	Thermal station with valves	T2 Fault OFF
<input type="checkbox"/> 3	T3 disabled	T3 Fault OFF
<input type="checkbox"/> 4	T3 only winter when enabled	Condensation OFF
<input checked="" type="checkbox"/> 5	Simultaneous ventilation of valves	
<input type="checkbox"/> 6	Unit without electrical heater	
<input type="checkbox"/> 7	T2 as CH Change-over (resistance phase II)	
<input type="checkbox"/> 8	UNIT ALERT	
<input type="checkbox"/> 9	Remote ON/OFF input	
<input type="checkbox"/> 10	MASTER	

Management system for a network of fan coils

Alarm control by E-mail and sms

In addition to the alarm set on the NET display, it is possible to send the ON-OFF alarm notification via E-mail and sms.

ALARMS

Ongoing alarms

At	Address	Unit name	Group	Alarm type
No alarms				

Alarms log

From	To	Address	Unit name	Group	Alarm type
No alarms					

Notification

Event type	eMail						SMS					
	none	instant	after 1 hour	after 3 hours	after 6 hours	at the end	none	instant	after 1 hour	after 3 hours	after 6 hours	at the end
Alarm on unit [any]	<input checked="" type="radio"/>	<input type="radio"/>	<input type="radio"/>	<input type="radio"/>	<input type="radio"/>	<input type="checkbox"/>	<input checked="" type="radio"/>	<input type="radio"/>	<input type="radio"/>	<input type="radio"/>	<input type="radio"/>	<input type="checkbox"/>
Condensate alarm on unit	<input checked="" type="radio"/>	<input type="radio"/>	<input type="radio"/>	<input type="radio"/>	<input type="radio"/>	<input type="checkbox"/>	<input checked="" type="radio"/>	<input type="radio"/>	<input type="radio"/>	<input type="radio"/>	<input type="radio"/>	<input type="checkbox"/>
Probe alarm on unit	<input checked="" type="radio"/>	<input type="radio"/>	<input type="radio"/>	<input type="radio"/>	<input type="radio"/>	<input type="checkbox"/>	<input checked="" type="radio"/>	<input type="radio"/>	<input type="radio"/>	<input type="radio"/>	<input type="radio"/>	<input type="checkbox"/>

Save

RS 485 serial connection cable

Shielded cable to be used:

Belden 9841, RS-485, 1x2x24 AWG SFTP, 120 Ohm

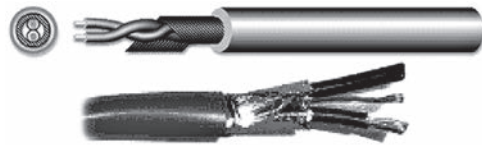

PC NET Software

Connection of a **SEC-ECM** or **HP-ECM** network with MB electronic board

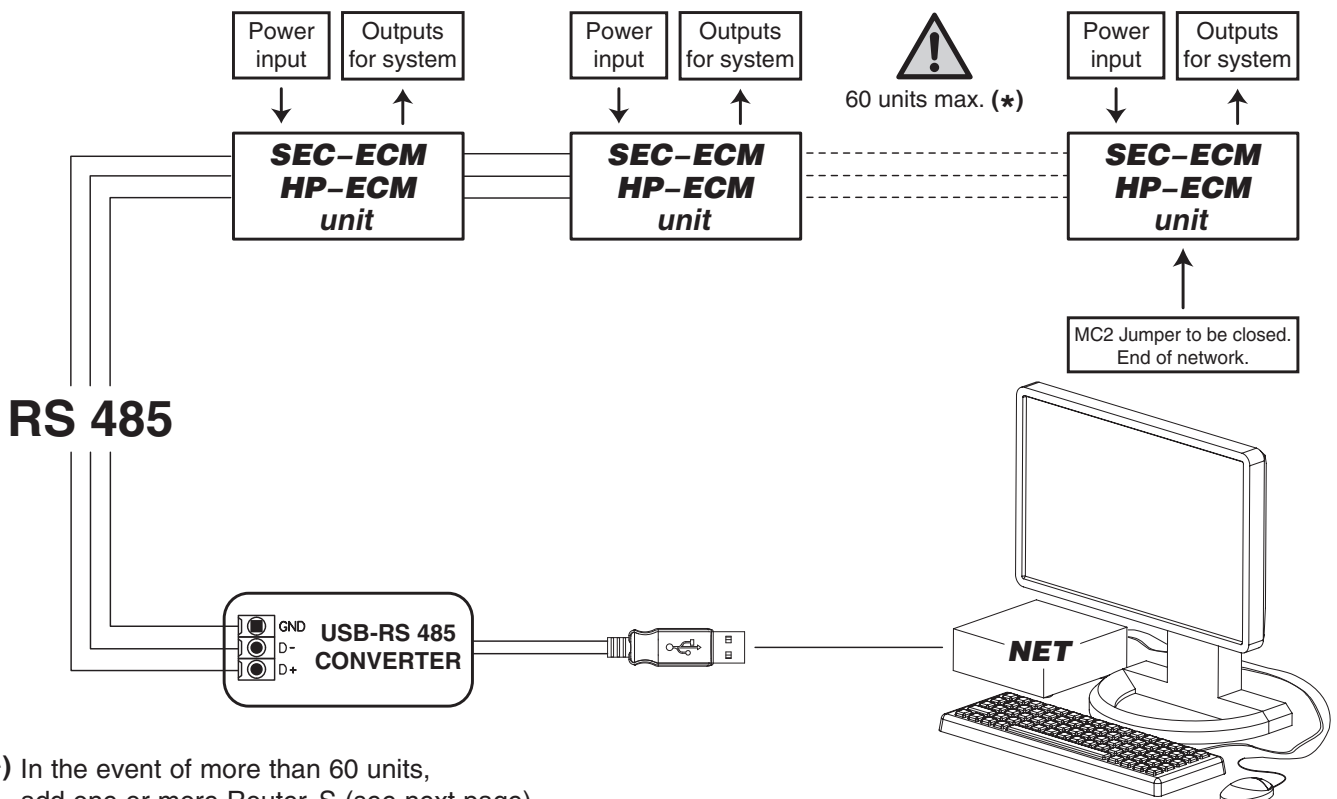

(*) In the event of more than 60 units, add one or more Router-S (see next page).

PSM-DI and NET electronic boards

IDENTIFICATION	CODE
SIOS	3021292

SIOS is a board equipped with 8 relays with potential free contact to control the activation or deactivation of remote electric utilities. Moreover, the board has 8 digital inlets to display the actuators or external consents, such as motor or other.

The SIOS boards can be connected:

- inside a network managed by NET;
- to a PSM-DI panel (one SIOS for each PSM-DI panel).

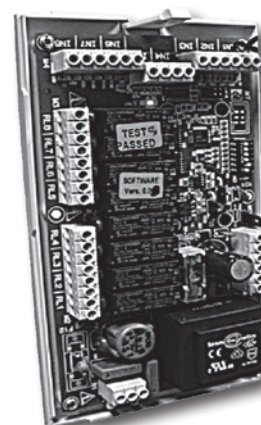

IDENTIFICATION	CODE
Router-S	3021290

The Router-S is an electronic board that allows to control several units inside a network managed by NET (default) or within a sub-network managed by BMS systems, that are not provided by York (it is necessary to operate on a Dip Switch on the board).

Managed by NET

The Router-S in the standard version is an electronic board that:

- allows creating networks with more than 60 units (minimum 2 Router-S are required) or to divide the network (per floor, building, etc.);
- it allows creating a Master/Slave sub-network to be controlled as an independent group.

The Router-S in the standard version can be used only inside a network managed by NET. The number of Router-S to be used is:

- up to 60 units: no Router-S
- from 61 to 120 units: 2 Router-S
- every 60 subsequent units: 1 additional Router-S

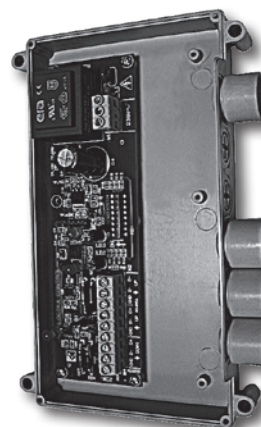

Managed by BMS Systems which are not provided

The Router-S becomes an electronic board to use with BMS systems not supplied, only after having set the Dip Switch on the board and so creating a Master/Slave sub-network to be controlled as an independent group.

The number of Router-S to use is:

- maximum 14 Router-S.
- maximum 15 fan coils per Router-S.

**The descriptions and illustrations provided in this publication are not binding:
we reserve the right, whilst maintaining the essential characteristics
of the types described and illustrated, to make, at any time,
without the requirement to promptly update this piece of literature,
any changes that it considers useful for the purpose
of improvement or for any other manufacturing or commercial requirements.**

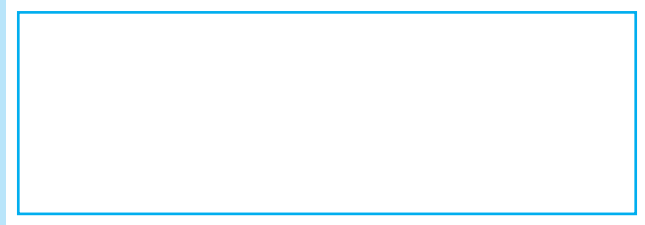

SEC/HP -ECM - 05/18
Cod. 99A4760160 D/05/18