



SEC/F-ECM

SEC/F-ECM Fan Coil Units

INTRODUCTION

SEC/F fan coil combine a beautiful design with very interesting performances in terms of sound level and energy consumption.

The **ECM** models are available in five different models, for wall and ceiling installation, with casing and concealed.

The **ECM** range makes use of the excellent experience gained with the Cassette fan coils with inverter board, first in the world in production since 2009, and which have had great success on all markets.

The innovative brushless and sensorless type synchronous electronic motor with permanent magnets, is controlled by an **inverter** board designed and developed in Italy. The board is mounted on the unit, closed to the motor, without the need to be cooled down by the air flow.

The air flow rate can be varied **in continuous** by means of a 1-10 V signal generated by our controls or by independent control systems. The continuous air flow control improves the acoustic comfort and allows a more punctual reply to the variation of the thermal loads and a greater stability of the requested ambient temperature.

The extreme efficiency, also at low speed, makes possible a great reduction in electric consumption (less than 50% in comparison to SEC/F range motor) with absorption values under normal operating conditions that **do not exceed 16 Watt for SEC/F-ECM models** on the entire range. The excellent values of the SEC/F range in terms of sound levels have been maintained **in all working conditions**, without any resonance phenomenon at any frequency. The full compliance with the Electromagnetic Compatibility Directive and with the other severe Standards in force is certified by an independent institute.

CONTENTS

• **SEC/F-ECM version**

• Construction	Page 4
• Models	Page 5
• Dimensions, Weight, Water content	Page 6
• Technical features	Page 10
• Operation limits	Page 13
• Emission tables	Page 14
• Correction factors table	Page 24
• Water pressure drop	Page 25
• Accessories	Page 26
• ECM configuration	Page 48
• Electronic controls	Page 49
• Controls and units MB version	Page 53
• Management system for a network of fan coils	Page 58
• PSM-DI and NET electronic boards	Page 62



SEC/F-ECM version with centrifugal fan

Range includes 5 air flow rates (from 115 to 1395 m³/h) and 5 models (for wall and ceiling installation, with casing and concealed), each equipped with 3 or 4 row coil and with the possibility to add a 1 or 2 row coil for 4 pipe systems.

It is the most comprehensive range, perfect to meet all air-conditioning requirements of work environments like offices, shops, restaurants and hotel rooms.

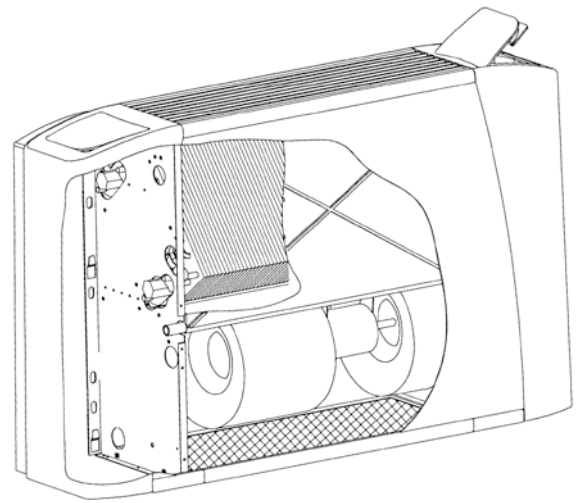

Outer casing

Made of strong synthetic lateral corners and from galvanized and pre-painted front steel panel. The plastic top grid has fixed louvres and is reversible in order to distribute the air in two different directions.

Standard colours:

- Lateral corners and top grid: **Pantone 427 C (light grey)**
- Frontal panel: **RAL 9003 (white)**
- Other colours on request.

Inner casing

Made from 1 mm galvanized steel insulated with 3 mm polyolefin (PO) foam (class M1).

Filter

Polypropylene cellular fabric regenerating filter. The filter frame of galvanized steel is inserted into special plastic sliding guides fastened to the internal structure for easy insertion and removal of the filter.

Filter presence is highlighted by a plastic front cover featuring the same colour as the top grid.

Fan assembly

The fans have aluminium or plastic blades directly keyed on the motor with double aspiration and they are dynamically and statically balanced during manufacture in order to have an extremely quiet operation.

Electronic motor

Three phase permanent magnet brushless electronic motor that is controlled with reconstructed current according to a BLAC sinusoidal wave. The inverter board that controls the motor operation is powered by 230 Volt, single-phase and, with a switching system, it generates a three-phase frequency modulated, wave form power supply. The electric power supply required for the machine is therefore single-phase with voltage of 230-240V and frequency of 50-60Hz.

Coil

It is manufactured from drawn copper tube and the aluminium fins are mechanically bonded onto the tube by an expansion process. The coil has two 1/2inch BSP internal connections and 1/8 inch BSP air vent and drain. The coil is not suitable for use in corrosive atmosphere or in environments where aluminium may be subject to corrosion.

The connections are on the left side facing the unit. On request we can deliver the unit with the connections on the right end side. This operation can also be easily carried out on site during installation.

Condensate collection tray

Made of plastic (ABS UL94 HB) with a "L-shaped" plastic fitted on the inner casing; in the CH, CVB and NC model the tray is insulated with 3 mm polyolefin (PO) foam (class M1). The outside diameter of the condensate discharge pipe is 15 mm.

Accessories and Controls

See page 26 and 53.

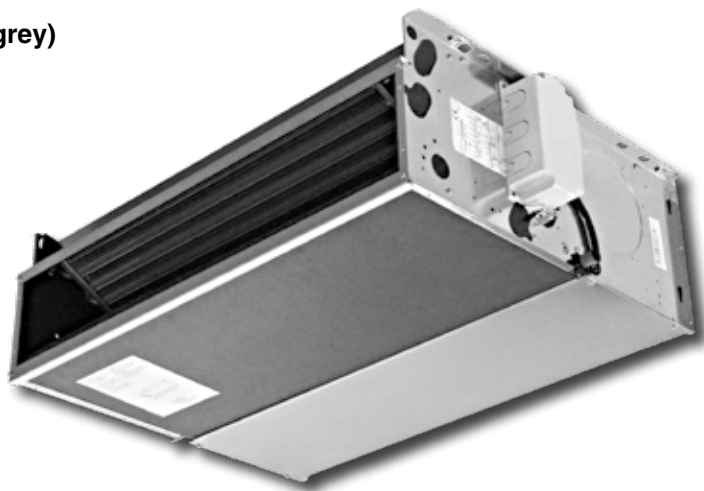

CV

Vertical Casing – Wall Installation

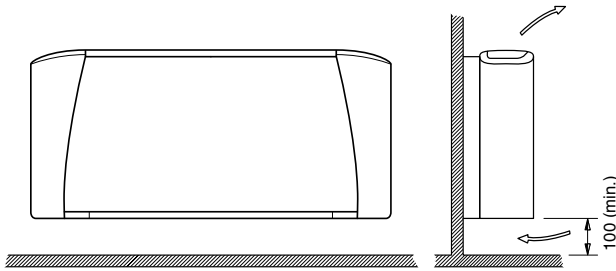

CV

Vertical Casing – Ceiling Installation

NOTE: the CV model can also be installed horizontally leaving behind a 100 mm gap for air intake.

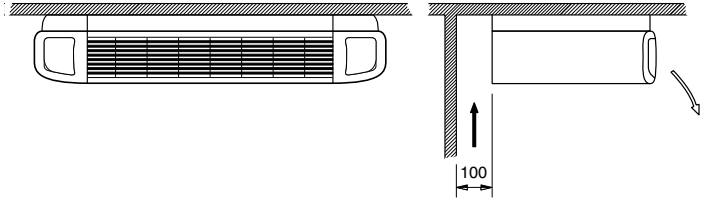

CVB

Vertical Casing – Floor Installation

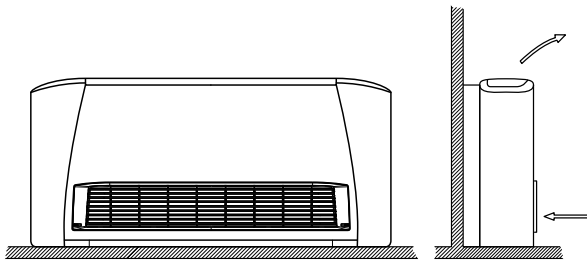

CH

Horizontal Casing

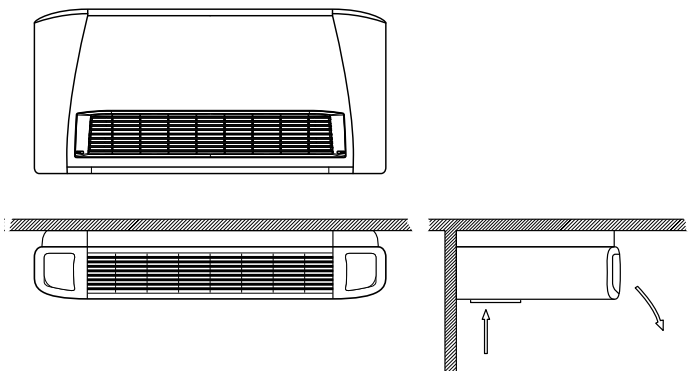

NC

Vertical Concealed

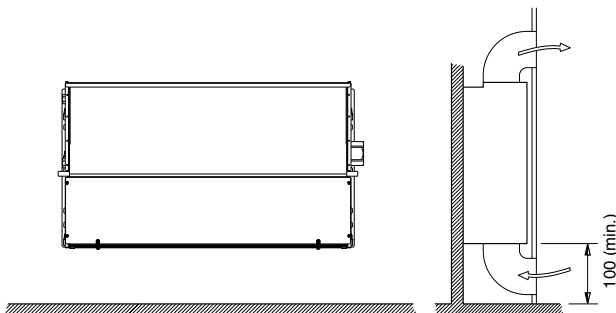

NC

Horizontal Concealed

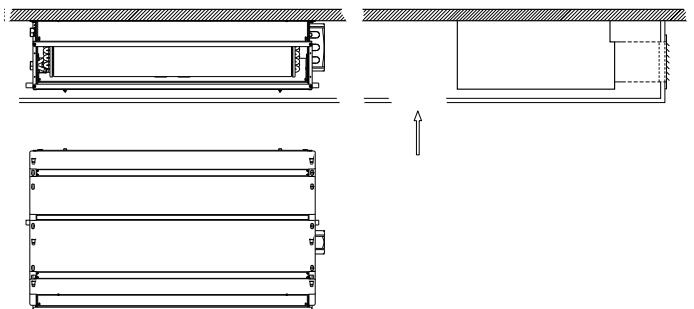

CV

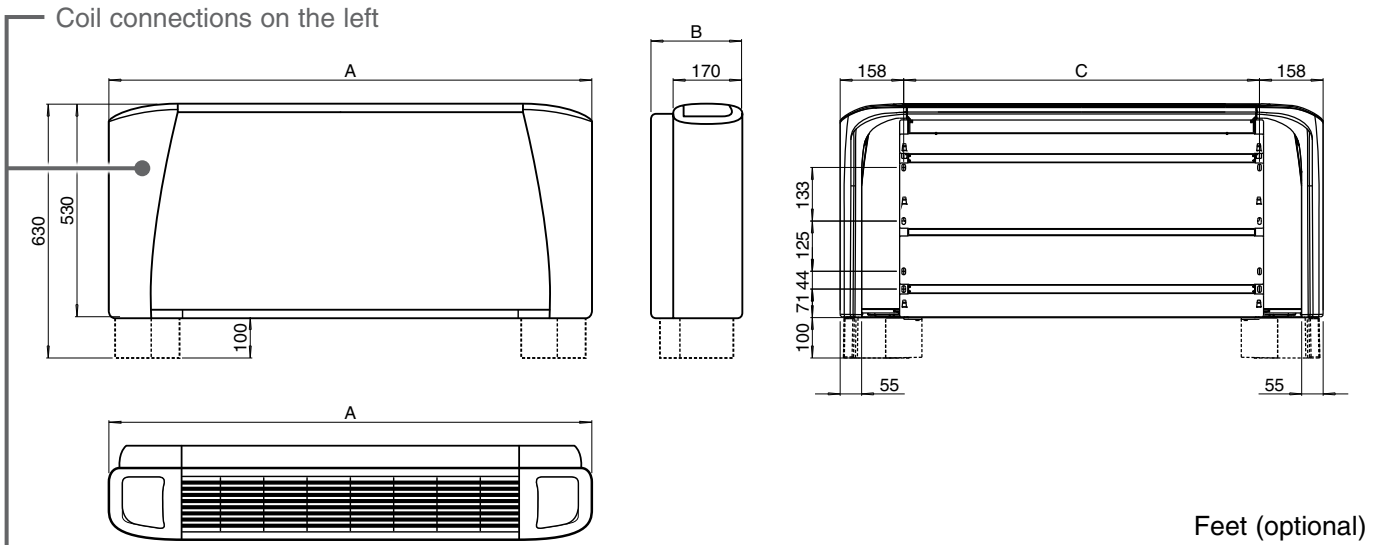

CH - CVB

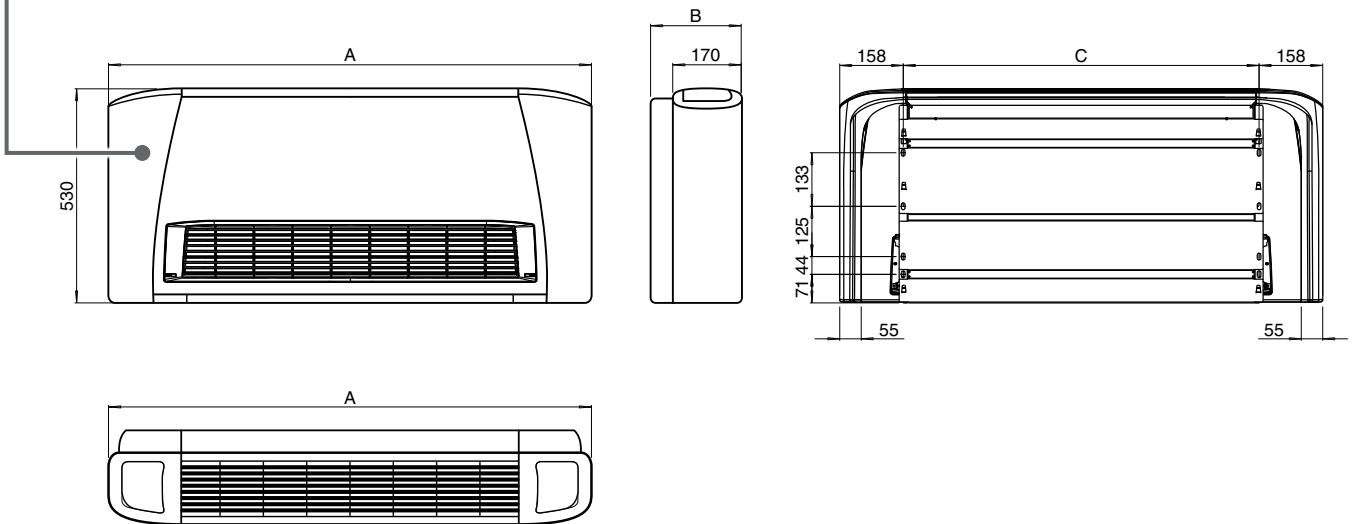

COIL CONNECTIONS

3 or 4 row coils

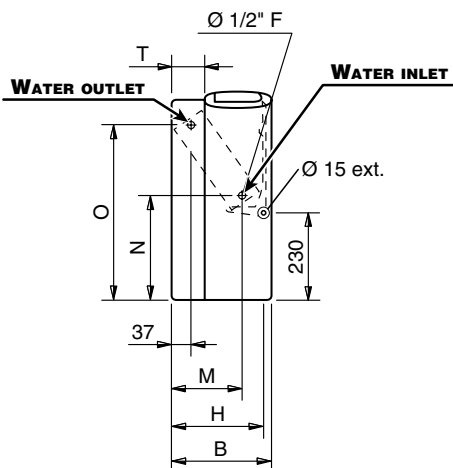

Heating additional coil (1 or 2 rows)

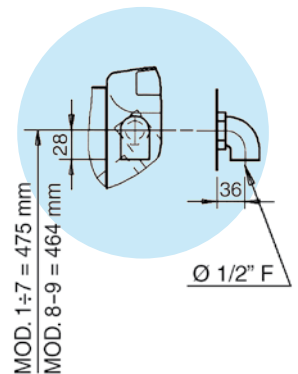
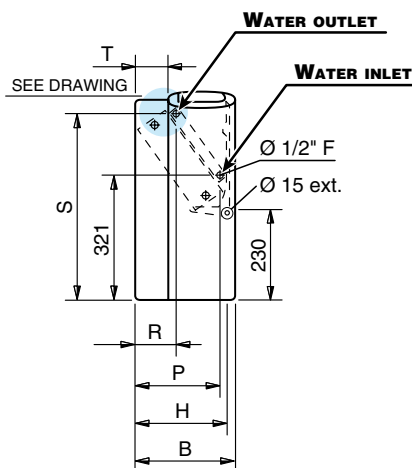

PACKAGING

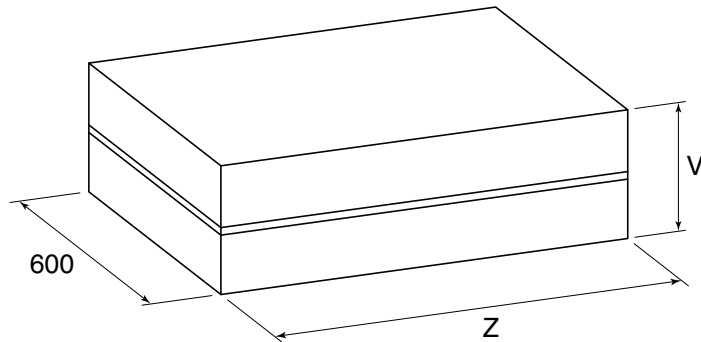

Dimension (mm)

MODEL	2	4	6	7	9
A	770	985	1200	1415	1415
B	225	225	225	225	255
C	454	669	884	1099	1099
H	205	205	205	205	235
M	145	145	145	145	170
N	260	260	260	260	270
O	460	460	460	460	450
P	185	185	185	185	210
R	105	105	105	105	110
S	475	475	475	475	465
T	55	55	55	55	85
V	260	260	260	260	290
Z	820	1035	1250	1465	1465

Weight (kg)

MODEL		WEIGHT WITH PACKAGING					WEIGHT WITHOUT PACKAGING				
		2	4	6	7	9	2	4	6	7	9
Rows	3	17,2	22,5	27,7	32,1	35,9	15,4	20,2	24,9	28,8	32,2
	3+1	18,0	23,7	29,2	33,9	37,7	16,2	21,4	26,4	30,6	34,0
	3+2	18,6	24,4	30,1	35,0	38,8	16,8	22,1	27,3	31,7	35,1
	4	18,0	23,5	29,0	33,6	37,4	16,2	21,2	26,2	30,3	33,7
	4+1	18,8	24,7	30,5	35,4	39,2	17,0	22,4	27,7	32,1	35,5

Water content (litres)

MODEL		2	4	6	7	9
Rows	3	0,6	0,9	1,6	1,7	1,9
	4	0,8	1,3	2,2	2,4	2,8
	+1	0,2	0,3	0,5	0,5	0,6
	+2	0,4	0,6	1,0	1,0	1,2

SEC/F-ECM | Dimension, Weight, Water content

NC Vertical Installation

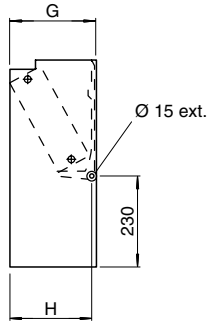
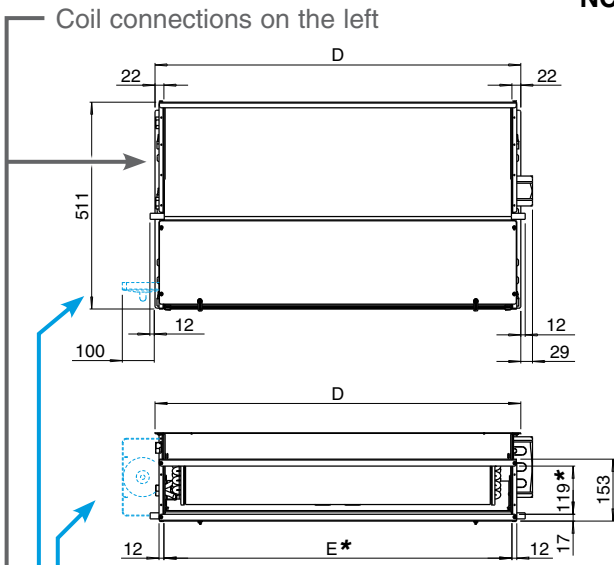

* Supply frame dimension = $E \times 119 \text{ mm}$

Auxiliary condensate tray (optional)

NC Horizontal Installation

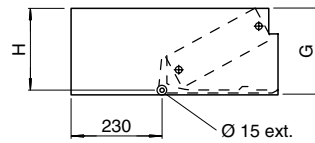
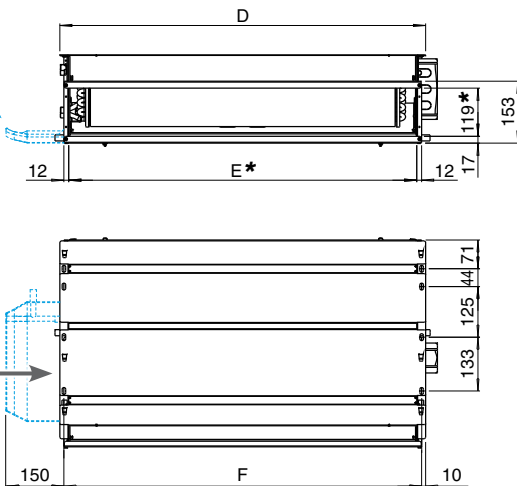

* Supply frame dimension = $E \times 119 \text{ mm}$

COIL CONNECTIONS

3 or 4 row coils

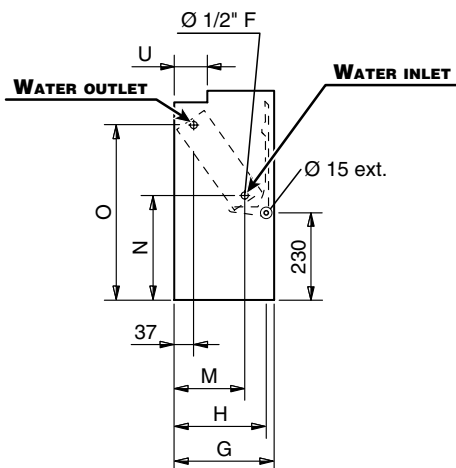

Heating additional coil (1 or 2 rows)

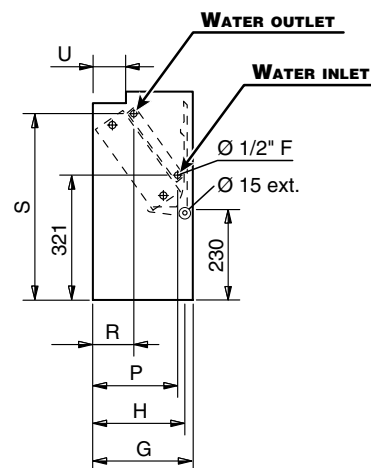

PACKAGING

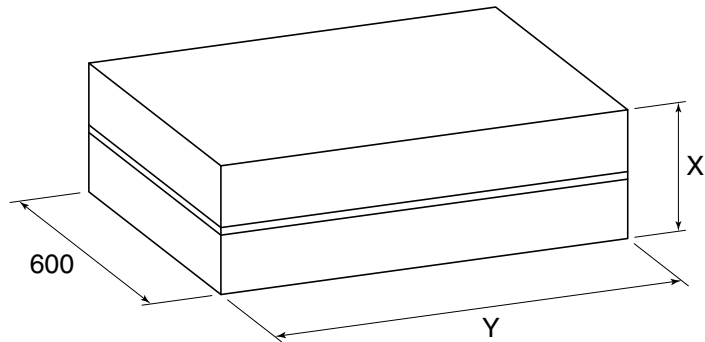

Dimension (mm)

MODEL	2	4	6	7	9
D	474	689	904	1119	1119
E	430	645	860	1075	1075
F	454	669	884	1099	1099
G	218	218	218	218	248
H	205	205	205	205	235
M	145	145	145	145	170
N	260	260	260	260	270
O	460	460	460	460	450
P	185	185	185	185	210
R	105	105	105	105	110
S	475	475	475	475	465
U	65	65	65	65	95
X	260	260	260	260	290
Y	820	820	1035	1250	1250

Weight (kg)

MODEL		WEIGHT WITH PACKAGING					WEIGHT WITHOUT PACKAGING				
		2	4	6	7	9	2	4	6	7	9
Rows	3	13,6	18,1	22,8	27,0	30,4	11,8	16,3	20,5	24,2	27,3
	3+1	14,4	19,3	24,3	28,8	32,2	12,6	17,5	22,0	26,0	29,1
	3+2	15,0	20,0	25,2	29,9	33,3	13,2	18,2	22,9	27,1	30,2
	4	14,4	19,1	24,1	28,5	31,9	12,6	17,3	21,8	25,7	28,8
	4+1	15,2	20,3	25,6	30,3	33,7	13,4	18,5	23,3	27,5	30,6

Water content (litres)

MODEL		2	4	6	7	9
Rows	3	0,6	0,9	1,6	1,7	1,9
	4	0,8	1,3	2,2	2,4	2,8
	+1	0,2	0,3	0,5	0,5	0,6
	+2	0,4	0,6	1,0	1,0	1,2

SEC/F-ECM UNITS WITH 3 ROW COIL

2 pipe units.

The following standard rating conditions are used:

COOLING

Entering air temperature +27°C d.b. +19°C w.b.
 Water temperature +7°C E.W.T. +12°C L.W.T.

HEATING

Entering air temperature +20°C
 Entering water temperature +45/40°C

MODEL	SEC/F-ECM 2.3-2T					SEC/F-ECM 4.3-2T					SEC/F-ECM 6.3-2T					
	1	3	5	7,5	10	1	3	5	7,5	10	1	3	5	7,5	10	
Inverter power																
Speed	MIN		MED		MAX	MIN		MED		MAX	MIN		MED		MAX	
Air flow	m ³ /h	120	170	220	270	330	210	280	350	430	515	305	395	495	610	735
Cooling total emission	kW	0,73	0,97	1,18	1,37	1,59	1,41	1,80	2,18	2,57	2,95	1,96	2,44	2,93	3,44	3,96
Cooling sensible emission	kW	0,55	0,74	0,92	1,09	1,28	1,03	1,33	1,64	1,95	2,26	1,46	1,83	2,22	2,64	3,08
Heating	kW	0,77	1,04	1,29	1,52	1,80	1,42	1,84	2,26	2,69	3,14	1,96	2,46	3,00	3,55	4,14
Dp Cooling	kPa	2,2	3,6	5,1	6,7	8,6	7,9	12,0	17,0	22,6	28,9	5,5	8,0	11,1	14,8	19,0
Dp Heating	kPa	1,6	2,7	3,9	5,2	7,0	6,6	10,4	14,9	20,4	26,7	4,5	6,8	9,6	12,9	17,0
Fan	W	7,0	9,0	11,0	15,0	21,0	6,0	9,0	12,0	17,0	25,0	7,0	10,0	15,0	22,0	32,0
Sound power	dB(A)	30	36	41	47	51	30	36	42	47	51	33	38	44	49	54
Sound pressure (*)	dB(A)	21	27	32	38	42	21	27	33	38	42	24	29	35	40	45

MODEL	SEC/F-ECM 7.3-2T					SEC/F-ECM 9.3-2T					
	1	3	5	7,5	10	1	3	5	7,5	10	
Inverter power											
Speed	MIN		MED		MAX	MIN		MED		MAX	
Air flow	m ³ /h	400	500	610	755	890	605	785	945	1175	1395
Cooling total emission	kW	2,60	3,13	3,68	4,36	4,94	3,45	4,22	4,82	5,60	6,26
Cooling sensible emission	kW	1,92	2,33	2,77	3,32	3,80	2,63	3,28	3,79	4,49	5,10
Heating	kW	2,56	3,13	3,72	4,43	5,08	3,74	4,65	5,41	6,46	7,38
Dp Cooling	kPa	10,5	14,5	19,4	26,1	32,6	8,9	12,7	16,1	21,1	25,9
Dp Heating	kPa	8,5	12,1	16,4	22,2	28,3	7,3	10,7	14,0	19,1	24,2
Fan	W	9,0	13,0	18,5	28,5	41,0	16,0	25,0	41,0	65,0	99,0
Sound power	dB(A)	37	43	48	53	57	44	50	55	60	64
Sound pressure (*)	dB(A)	28	34	39	44	48	35	41	46	51	55

(*) = The sound pressure levels are 9 dB(A) lower than the sound power levels and apply to the reverberant field of a 100 m³ room and a reverberation time of 0.5 sec.

SEC/F-ECM UNITS WITH 4 ROW COIL

2 pipe units.

The following standard rating conditions are used:

COOLING

Entering air temperature +27°C d.b. +19°C w.b.
 Water temperature +7°C E.W.T. +12°C L.W.T.

HEATING

Entering air temperature +20°C
 Entering water temperature +45/40°C

MODEL		SEC/F-ECM 2.4-2T					SEC/F-ECM 4.4-2T					SEC/F-ECM 6.4-2T				
		1	3	5	7,5	10	1	3	5	7,5	10	1	3	5	7,5	10
Inverter power																
Speed		MIN		MED		MAX	MIN		MED		MAX	MIN		MED		MAX
Air flow	m³/h	115	160	210	260	325	200	265	340	415	505	290	375	475	590	720
Cooling total emission	kW	0,77	1,06	1,32	1,57	1,86	1,43	1,83	2,27	2,71	3,17	2,05	2,59	3,19	3,84	4,51
Cooling sensible emission	kW	0,56	0,78	0,98	1,19	1,42	1,03	1,34	1,67	2,02	2,39	1,48	1,89	2,34	2,84	3,38
Heating	kW	0,78	1,08	1,37	1,65	1,98	1,42	1,83	2,30	2,77	3,32	2,02	2,59	3,23	3,93	4,68
Dp Cooling	kPa	3,2	5,5	8,0	11,0	14,8	4,0	6,1	8,9	12,3	16,1	8,2	12,4	17,8	24,8	33,0
Dp Heating	kPa	2,6	4,7	7,1	9,9	13,6	3,1	4,9	7,3	10,2	13,7	6,6	10,3	15,1	21,4	29,1
Fan	W	7,0	8,8	11,0	14,6	21,0	6,0	9,0	12,0	17,0	25,0	7,0	10,0	15,0	22,0	32,0
Sound power	dB(A)	30	36	41	47	51	30	36	42	47	51	33	38	44	49	54
Sound pressure (*)	dB(A)	21	27	32	38	42	21	27	33	38	42	24	29	35	40	45

MODEL		SEC/F-ECM 7.4-2T					SEC/F-ECM 9.4-2T				
		1	3	5	7,5	10	1	3	5	7,5	10
Inverter power											
Speed		MIN		MED		MAX	MIN		MED		MAX
Air flow	m³/h	380	475	585	735	875	575	755	910	1145	1365
Cooling total emission	kW	2,61	3,20	3,82	4,61	5,30	3,59	4,49	5,21	6,18	7,04
Cooling sensible emission	kW	1,90	2,34	2,82	3,44	3,99	2,69	3,40	3,99	4,81	5,53
Heating	kW	2,57	3,17	3,84	4,66	5,43	3,76	4,81	5,63	6,84	7,93
Dp Cooling	kPa	7,3	10,5	14,3	20,0	25,6	6,3	9,3	12,1	16,4	20,8
Dp Heating	kPa	5,9	8,6	12,0	16,9	22,0	5,6	8,7	11,4	16,1	20,9
Fan	W	9,0	13,0	18,5	28,5	41,0	16,0	25,0	41,0	65,0	99,0
Sound power	dB(A)	37	43	48	53	57	44	50	55	60	64
Sound pressure (*)	dB(A)	28	34	39	44	48	35	41	46	51	55

(*) = The sound pressure levels are 9 dB(A) lower than the sound power levels and apply to the reverberant field of a 100 m³ room and a reverberation time of 0.5 sec.

SEC/F-ECM UNITS WITH 1 ROW ADDITIONAL COIL

4 pipe units.

The following standard rating conditions are used:

COOLING

Entering air temperature +27°C d.b. +19°C w.b.
 Water temperature +7°C E.W.T. +12°C L.W.T.

HEATING

Entering air temperature +20°C
 Entering water temperature +65/55°C

MODEL	SEC/F-ECM 2.3-4T					SEC/F-ECM 4.3-4T					SEC/F-ECM 6.3-4T					
	1	3	5	7,5	10	1	3	5	7,5	10	1	3	5	7,5	10	
Inverter power																
Speed	MIN		MED		MAX	MIN		MED		MAX	MIN		MED		MAX	
Air flow	m ³ /h	120	170	220	270	330	210	280	350	430	515	305	395	495	610	735
Cooling total emission	kW	0,73	0,97	1,18	1,37	1,59	1,41	1,80	2,18	2,57	2,95	1,96	2,44	2,93	3,44	3,96
Cooling sensible emission	kW	0,55	0,74	0,92	1,09	1,28	1,03	1,33	1,64	1,95	2,26	1,46	1,83	2,22	2,64	3,08
Heating	kW	0,71	0,91	1,08	1,24	1,43	1,29	1,57	1,85	2,13	2,41	1,76	2,10	2,45	2,83	3,22
Dp Cooling	kPa	2,3	3,8	5,4	7,2	9,4	7,3	11,5	16,0	21,6	28,1	6,4	9,6	13,2	17,7	23,3
Dp Heating	kPa	1,0	1,6	2,1	2,7	3,5	3,6	5,2	6,9	8,8	11,0	1,2	1,7	2,2	2,9	3,6
Fan	W	7,0	9,0	11,0	14,5	21,0	6,0	9,0	12,0	17,0	25,0	7,0	10,0	15,0	22,0	32,0
Sound power	dB(A)	30	36	41	47	51	30	36	42	47	51	33	38	44	49	54
Sound pressure (*)	dB(A)	21	27	32	38	42	21	27	33	38	42	24	29	35	40	45

MODEL	SEC/F-ECM 7.3-4T					SEC/F-ECM 9.3-4T					
	1	3	5	7,5	10	1	3	5	7,5	10	
Inverter power											
Speed	MIN		MED		MAX	MIN		MED		MAX	
Air flow	m ³ /h	400	500	610	755	890	605	785	945	1175	1395
Cooling total emission	kW	2,60	3,13	3,68	4,36	4,94	3,45	4,22	4,82	5,60	6,26
Cooling sensible emission	kW	1,92	2,33	2,77	3,32	3,80	2,63	3,28	3,79	4,49	5,10
Heating	kW	2,33	2,72	3,12	3,63	4,06	2,99	3,58	4,05	4,69	5,24
Dp Cooling	kPa	9,7	13,8	18,4	24,8	31,8	8,9	12,7	16,1	21,1	25,9
Dp Heating	kPa	2,4	3,1	4,0	5,2	6,3	3,7	5,1	6,3	8,2	9,9
Fan	W	9,0	13,0	18,5	28,5	41,0	16,0	25,0	41,0	65,0	99,0
Sound power	dB(A)	37	43	48	53	57	44	50	55	60	64
Sound pressure (*)	dB(A)	28	34	39	44	48	35	41	46	51	55

(*) = The sound pressure levels are 9 dB(A) lower than the sound power levels and apply to the reverberant field of a 100 m³ room and a reverberation time of 0.5 sec.

Highest water inlet temperature + 85 °C

Lowest water inlet temperature..... + 6 °C
 for entering water temperatures below + 6 °C, contact the technical department

Highest working pressure 1000 kPa (10 bars)

Note: For CH model the maximum installation height is 2,8 m. On heating it must be payed attention to rooms where the floor temperature is particularly low (for example less than 6 °C). In this situation the floor can cool the lower layer of air to a level that can stop the uniform diffusion of the hot air coming from the unit.

Water flow limits for 3 row coil (l/h) _____

MODEL	SEC/F-ECM 2.3	SEC/F-ECM 4.3	SEC/F-ECM 6.3	SEC/F-ECM 7.3	SEC/F-ECM 9.3
Lowest	100	100	150	150	200
Highest	500	750	1000	1500	2000

Water flow limits for 4 row coil (l/h) _____

MODEL	TEC-ECM 2.4	TEC-ECM 4.4	TEC-ECM 6.4	TEC-ECM 7.4	TEC-ECM 9.4
Lowest	100	150	150	200	300
Highest	750	1000	1500	2000	2250

Water flow limits for 1 row additional coil (l/h) _____

MODEL	TEC-ECM 2	TEC-ECM 4	TEC-ECM 6	TEC-ECM 7	TEC-ECM 9
Lowest	50	50	100	100	100
Highest	250	350	500	650	750

Water flow limits for 2 row additional coil (l/h) _____

MODEL	TEC-ECM 2	TEC-ECM 4	TEC-ECM 6	TEC-ECM 7	TEC-ECM 9
Lowest	50	100	100	100	100
Highest	250	350	500	650	750

Motor electrical data (max. absorption)

MODEL		TEC-ECM 2	TEC-ECM 4	TEC-ECM 6	TEC-ECM 7	TEC-ECM 9
230/1 50Hz	W	21,0	25,0	32,0	41,0	99,0
	A	0,18	0,22	0,28	0,34	0,81

Cooling emission of 3 row coil

Entering air temperature: 27°C – R.H.: 50%

MOD.	Vdc	Qv m ³ /h	WT: 7/12 °C				WT: 8/13 °C				WT: 10/15 °C				WT: 12/17 °C			
			Pc kW	Ps kW	Qw l/h	Dp(c) kPa	Pc kW	Ps kW	Qw l/h	Dp(c) kPa	Pc kW	Ps kW	Qw l/h	Dp(c) kPa	Pc kW	Ps kW	Qw l/h	Dp(c) kPa
SEC/F ECM 2.3	10	330	1,72	1,27	299	7,9	1,53	1,19	266	6,4	1,12	1,04	196	3,7	0,90	0,90	159	2,5
	7,5	270	1,49	1,08	258	6,1	1,32	1,02	230	4,9	0,98	0,88	171	2,9	0,77	0,77	135	1,9
	5	220	1,27	0,91	220	4,6	1,13	0,86	196	3,7	0,84	0,74	147	2,2	0,66	0,66	115	1,4
	3	170	1,04	0,74	181	3,3	0,93	0,69	162	2,7	0,70	0,60	121	1,6	0,53	0,53	93	1,0
	1	120	0,79	0,55	137	2,0	0,71	0,52	123	1,6	0,53	0,45	93	1,0	0,39	0,39	69	0,6
SEC/F ECM 4.3	10	515	3,17	2,25	550	32,9	2,84	2,11	493	27,0	2,14	1,84	373	16,3	1,62	1,62	283	9,9
	7,5	430	2,76	1,94	478	25,8	2,48	1,82	429	21,2	1,88	1,59	326	12,8	1,40	1,40	243	7,6
	5	350	2,35	1,63	406	19,3	2,11	1,53	365	15,9	1,60	1,33	278	9,7	1,18	1,18	204	5,6
	3	280	1,93	1,33	334	13,7	1,74	1,25	300	11,3	1,33	1,08	229	6,9	0,96	0,96	167	3,9
	1	210	1,52	1,03	262	8,9	1,37	0,97	236	7,4	1,05	0,84	181	4,6	0,74	0,74	129	2,5
SEC/F ECM 6.3	10	735	4,26	3,07	738	21,6	3,81	2,89	661	17,6	2,86	2,52	498	10,6	2,21	2,21	386	6,7
	7,5	610	3,70	2,63	641	16,8	3,32	2,48	574	13,8	2,50	2,16	434	8,3	1,90	1,90	331	5,1
	5	495	3,15	2,21	544	12,6	2,82	2,08	488	10,3	2,14	1,81	370	6,3	1,59	1,59	277	3,7
	3	395	2,62	1,83	453	9,1	2,36	1,71	407	7,5	1,79	1,49	310	4,6	1,32	1,32	229	2,7
	1	305	2,12	1,46	365	6,3	1,90	1,37	329	5,2	1,45	1,19	251	3,2	1,05	1,05	182	1,8
SEC/F ECM 7.3	10	890	5,31	3,79	921	37,1	4,04	3,56	702	30,4	3,60	3,11	627	18,5	2,74	2,74	478	11,3
	7,5	755	4,69	3,31	812	29,7	4,21	3,11	729	24,4	3,20	2,71	555	14,9	2,39	2,39	416	8,8
	5	610	3,96	2,76	684	22,0	3,56	2,60	615	18,1	2,71	2,26	470	11,1	1,99	1,99	346	6,4
	3	500	3,37	2,33	581	16,5	3,03	2,19	523	13,6	2,32	1,90	400	8,4	1,69	1,69	292	4,8
	1	400	2,79	1,92	482	11,9	2,52	1,80	434	9,8	1,93	1,57	333	6,1	1,38	1,38	240	3,4
SEC/F ECM 9.3	10	1395	6,76	5,06	1180	30,3	6,01	4,76	1051	24,7	4,43	4,17	780	14,6	3,63	3,63	642	10,4
	7,5	1175	6,05	4,46	1051	24,7	5,39	4,20	938	20,2	3,99	3,67	698	12,0	3,21	3,21	563	8,2
	5	945	5,19	3,77	900	18,8	4,64	3,55	804	15,4	3,46	3,10	602	9,3	2,71	2,71	474	6,1
	3	785	4,55	3,27	787	14,8	4,07	3,07	704	12,2	3,05	2,68	529	7,4	2,35	2,35	409	4,6
	1	605	3,72	2,63	642	10,4	3,33	2,47	575	8,6	2,51	2,15	434	5,2	1,90	1,90	330	3,1

Legend

WT = Water temperature
Pc = Cooling total emission
Ps = Cooling sensible emission
Qw = Water flow
Dp(c) = Water pressure drop
Vdc = Inverter Power
Qv = Air flow

Cooling emission of 3 row coil

Entering air temperature: 26°C – R.H.: 50%

MOD.	Vdc	WT: 7/12 °C					WT: 8/13 °C					WT: 10/15 °C					WT: 12/17 °C				
		Qv m³/h	Pc kW	Ps kW	Qw l/h	Dp(c) kPa	Pc kW	Ps kW	Qw l/h	Dp(c) kPa	Pc kW	Ps kW	Qw l/h	Dp(c) kPa	Pc kW	Ps kW	Qw l/h	Dp(c) kPa			
SEC/F ECM 2.3	10	330	1,52	1,19	265	6,4	1,33	1,12	232	5,0	0,99	0,99	173	3,0	0,82	0,82	145	2,1			
	7,5	270	1,32	1,02	229	4,9	1,15	0,95	201	3,9	0,84	0,84	147	2,2	0,70	0,70	123	1,6			
	5	220	1,13	0,86	195	3,7	0,99	0,80	172	3,0	0,69	0,69	121	1,6	0,60	0,60	105	1,2			
	3	170	0,93	0,70	161	2,7	0,82	0,65	142	2,1	0,57	0,56	100	1,1	0,48	0,48	85	0,8			
	1	120	0,70	0,52	122	1,6	0,62	0,48	108	1,3	0,44	0,41	77	0,7	0,36	0,36	63	0,5			
SEC/F ECM 4.3	10	515	2,82	2,12	490	26,9	2,49	1,98	433	21,5	1,78	1,70	311	11,8	1,48	1,48	259	8,5			
	7,5	430	2,46	1,83	426	21,1	2,18	1,71	377	16,9	1,57	1,47	272	9,4	1,28	1,28	223	6,5			
	5	350	2,10	1,54	362	15,8	1,86	1,44	323	12,7	1,34	1,24	233	7,1	1,08	1,08	187	4,8			
	3	280	1,73	1,25	298	11,2	1,53	1,17	265	9,0	1,11	1,01	193	5,1	0,88	0,88	153	3,3			
	1	210	1,36	0,97	234	7,3	1,20	0,91	208	5,9	0,88	0,78	153	3,4	0,68	0,68	118	2,1			
SEC/F ECM 6.3	10	735	3,79	2,89	658	17,6	3,34	2,71	580	14,0	2,37	2,33	413	7,6	2,02	2,02	353	5,7			
	7,5	610	3,30	2,48	571	13,7	2,91	2,32	504	11,0	2,08	2,00	361	6,0	1,74	1,74	302	4,3			
	5	495	2,81	2,08	485	10,3	2,48	1,95	429	8,2	1,78	1,68	309	4,6	1,46	1,46	253	3,2			
	3	395	2,34	1,72	404	7,5	2,07	1,61	358	6,0	1,50	1,38	260	3,4	1,21	1,21	209	2,3			
	1	305	1,89	1,37	326	5,1	1,68	1,28	289	4,1	1,22	1,10	211	2,3	0,96	0,96	167	1,5			
SEC/F ECM 7.3	10	890	4,74	3,57	822	30,4	4,19	3,34	727	24,3	3,00	2,88	523	13,4	2,50	2,50	437	9,7			
	7,5	755	4,19	3,12	725	24,3	3,70	2,92	642	19,5	2,67	2,51	464	10,9	2,18	2,18	381	7,6			
	5	610	3,54	2,60	611	18,0	3,13	2,53	542	14,5	2,27	2,10	394	8,2	1,82	1,82	317	5,5			
	3	500	3,01	2,19	520	13,6	2,67	2,05	462	10,9	1,95	1,77	337	6,2	1,54	1,54	268	4,1			
	1	400	2,50	1,80	431	9,8	2,22	1,69	383	7,9	1,63	1,45	281	4,5	1,27	1,27	220	2,9			
SEC/F ECM 9.3	10	1395	6,00	4,77	1048	24,5	5,25	4,47	920	19,5	3,96	3,96	699	12,0	3,30	3,30	585	8,8			
	7,5	1175	5,37	4,21	934	20,0	4,71	3,94	821	16,0	3,50	3,50	613	9,6	2,92	2,92	513	7,0			
	5	945	4,61	3,56	801	15,3	4,06	3,33	705	12,2	2,96	2,96	515	7,0	2,47	2,47	432	5,1			
	3	785	4,05	3,08	700	12,1	3,56	2,88	617	9,7	2,52	2,48	438	5,3	2,15	2,15	373	3,9			
	1	605	3,31	2,48	572	8,5	2,92	2,32	505	6,8	2,08	1,99	361	3,7	1,74	1,74	302	2,6			

Legend

- WT = Water temperature
- Pc = Cooling total emission
- Ps = Cooling sensible emission
- Qw = Water flow
- Dp(c) = Water pressure drop
- Vdc = Inverter Power
- Qv = Air flow

Cooling emission of 3 row coil

Entering air temperature: 25°C – R.H.: 50%

MOD.	Vdc	Qv m ³ /h	WT: 7/12 °C				WT: 8/13 °C				WT: 10/15 °C				WT: 12/17 °C			
			Pc kW	Ps kW	Qw l/h	Dp(c) kPa	Pc kW	Ps kW	Qw l/h	Dp(c) kPa	Pc kW	Ps kW	Qw l/h	Dp(c) kPa	Pc kW	Ps kW	Qw l/h	Dp(c) kPa
SEC/F ECM 2.3	10	330	1,33	1,12	232	5,0	1,13	1,04	198	3,8	0,90	0,90	159	2,5	0,74	0,74	131	1,8
	7,5	270	1,15	0,96	200	3,9	0,99	0,89	172	3,0	0,77	0,78	135	1,9	0,63	0,63	111	1,3
	5	220	0,99	0,80	171	3,0	0,85	0,75	147	2,3	0,66	0,66	115	1,4	0,54	0,54	94	1,0
	3	170	0,81	0,65	141	2,1	0,70	0,60	122	1,6	0,53	0,53	93	1,0	0,44	0,44	77	0,7
	1	120	0,62	0,48	108	1,3	0,53	0,45	93	1,0	0,39	0,39	69	0,6	0,32	0,32	57	0,4
SEC/F ECM 4.3	10	515	2,49	1,99	432	21,6	2,15	1,85	375	16,7	1,63	1,63	284	10,1	1,34	1,34	235	7,1
	7,5	430	2,17	1,71	376	16,9	1,88	1,59	327	13,1	1,40	1,40	244	7,7	1,16	1,16	202	5,5
	5	350	1,85	1,44	320	12,7	1,61	1,34	278	9,9	1,18	1,18	205	5,7	0,97	0,97	170	4,0
	3	280	1,52	1,17	264	9,0	1,33	1,09	230	7,1	0,97	0,97	168	4,0	0,80	0,80	139	2,8
	1	210	1,20	0,91	207	5,9	1,05	0,84	181	4,6	0,75	0,74	130	2,5	0,62	0,62	108	1,8
SEC/F ECM 6.3	10	735	3,34	2,71	579	14,1	2,88	2,53	501	10,8	2,22	2,22	387	6,8	1,82	1,82	319	4,8
	7,5	610	2,90	2,33	503	11,0	2,51	2,17	436	8,5	1,90	1,91	331	5,2	1,57	1,57	274	3,6
	5	495	2,47	1,96	428	8,3	2,14	1,82	371	6,4	1,60	1,60	277	3,8	1,32	1,32	229	2,7
	3	395	2,07	1,61	357	6,0	1,80	1,50	310	4,7	1,33	1,33	230	2,7	1,10	1,10	190	1,9
	1	305	1,67	1,28	288	4,1	1,45	1,19	251	3,2	1,06	1,05	183	1,8	0,87	0,87	151	1,3
SEC/F ECM 7.3	10	890	4,18	3,35	726	24,4	3,63	3,12	631	18,9	2,74	2,74	479	11,5	2,26	2,26	396	8,1
	7,5	755	3,69	2,93	640	19,6	3,21	2,73	557	15,2	2,40	2,40	417	9,0	1,98	1,98	345	6,4
	5	610	3,12	2,44	541	14,5	2,72	2,27	471	11,3	2,00	2,00	347	6,5	1,65	1,65	287	4,6
	3	500	2,66	2,06	460	10,9	2,32	1,92	401	8,5	1,69	1,70	293	4,9	1,40	1,40	243	3,4
	1	400	2,21	1,69	382	7,9	1,93	1,57	334	6,2	1,33	1,39	230	3,4	1,15	1,15	200	2,4
SEC/F ECM 9.3	10	1395	5,25	4,48	920	19,5	4,49	4,18	789	14,9	3,63	3,63	642	10,4	2,97	2,97	528	7,4
	7,5	1175	4,70	3,95	820	15,9	4,04	3,68	706	12,2	3,21	3,22	563	8,2	2,63	2,63	464	5,8
	5	945	4,05	3,33	703	12,2	3,49	3,11	607	9,4	2,72	2,72	474	6,1	2,23	2,23	391	4,3
	3	785	3,56	2,89	616	9,6	3,07	2,69	532	7,5	2,36	2,36	409	4,7	1,94	1,94	337	3,2
	1	605	2,91	2,32	503	6,8	2,52	2,16	436	5,2	1,91	1,90	331	3,1	1,57	1,57	273	2,1

Legend

- WT = Water temperature
- Pc = Cooling total emission
- Ps = Cooling sensible emission
- Qw = Water flow
- Dp(c) = Water pressure drop
- Vdc = Inverter Power
- Qv = Air flow

Cooling emission of 4 row coil

Entering air temperature: 27°C – R.H.: 50%

MOD.	Vdc	WT: 7/12 °C					WT: 8/13 °C					WT: 10/15 °C					WT: 12/17 °C				
		Qv m³/h	Pc kW	Ps kW	Qw l/h	Dp(c) kPa	Pc kW	Ps kW	Qw l/h	Dp(c) kPa	Pc kW	Ps kW	Qw l/h	Dp(c) kPa	Pc kW	Ps kW	Qw l/h	Dp(c) kPa			
SEC/F ECM 2.4	10	325	2,00	1,42	348	16,9	1,79	1,33	312	13,8	1,35	1,16	235	8,3	1,02	1,02	179	5,0			
	7,5	260	1,69	1,18	294	12,5	1,52	1,11	264	10,3	1,15	0,97	200	6,2	0,85	0,85	149	3,7			
	5	210	1,42	0,98	245	9,1	1,27	0,92	220	7,5	0,96	0,80	168	4,6	0,71	0,71	123	2,6			
	3	160	1,14	0,78	197	6,2	1,02	0,73	178	5,1	0,78	0,64	136	3,1	0,56	0,56	98	1,8			
	1	115	0,84	0,57	145	3,6	0,75	0,53	131	3,0	0,58	0,46	100	1,9	0,41	0,41	71	1,0			
SEC/F ECM 4.4	10	505	3,42	2,38	592	18,5	3,06	2,23	531	15,2	2,32	1,94	403	9,2	1,71	1,71	299	5,4			
	7,5	415	2,92	2,02	506	14,0	2,63	1,89	454	11,5	2,00	1,64	346	7,0	1,45	1,45	253	4,0			
	5	340	2,44	1,67	421	10,1	2,19	1,56	379	8,4	1,67	1,36	290	5,1	1,20	1,20	208	2,8			
	3	265	1,97	1,34	340	7,0	1,77	1,25	307	5,8	1,36	1,09	235	3,6	0,96	0,96	167	1,9			
	1	200	1,54	1,04	266	4,5	1,39	0,97	240	3,7	1,07	0,84	185	2,3	0,75	0,75	129	1,2			
SEC/F ECM 6.4	10	720	4,85	3,36	839	37,4	4,36	3,16	755	30,9	3,32	2,75	577	19,0	2,43	2,43	423	10,8			
	7,5	590	4,12	2,84	713	28,1	3,71	2,67	642	23,2	2,84	2,32	492	14,3	2,05	2,05	356	8,0			
	5	475	3,42	2,33	590	20,2	3,08	2,19	533	16,7	2,37	1,91	409	10,4	1,69	1,69	293	5,7			
	3	375	2,79	1,89	481	14,1	2,52	1,78	434	11,7	1,94	1,54	335	7,3	1,36	1,36	236	3,9			
	1	290	2,20	1,48	379	9,2	1,99	1,39	343	7,7	1,54	1,21	265	4,8	1,07	1,07	184	2,5			
SEC/F ECM 7.4	10	875	5,70	3,98	987	29,1	5,12	3,74	888	24,0	3,90	3,26	677	14,7	2,87	2,87	501	8,5			
	7,5	735	4,95	3,43	857	22,7	4,46	3,23	771	18,7	3,40	2,81	590	11,5	2,47	2,47	431	6,5			
	5	585	4,11	2,82	710	16,3	3,70	2,65	639	13,5	2,83	2,30	491	8,3	2,04	2,04	354	4,6			
	3	475	3,43	2,34	593	11,9	3,10	2,20	535	9,8	2,38	1,91	412	6,1	1,69	1,69	293	3,3			
	1	380	2,81	1,90	484	8,3	2,53	1,79	437	6,9	1,95	1,55	337	4,3	1,37	1,37	237	2,3			
SEC/F ECM 9.4	10	1365	7,60	5,50	1324	23,7	6,77	5,17	1182	19,3	5,04	4,51	883	11,4	3,94	3,94	695	7,4			
	7,5	1145	6,68	4,79	1160	18,8	5,96	4,50	1037	15,3	4,46	3,91	778	9,1	3,43	3,43	602	5,7			
	5	910	5,61	3,97	972	13,8	5,02	3,73	871	11,3	3,77	3,24	656	6,8	2,85	2,85	497	4,1			
	3	755	4,84	3,40	837	10,6	4,34	3,19	750	8,7	3,27	2,77	567	5,2	2,45	2,45	426	3,1			
	1	575	3,87	2,69	669	7,1	3,48	2,52	601	5,9	2,64	2,19	456	3,6	1,93	1,93	335	2,0			

Legend

- WT = Water temperature
- Pc = Cooling total emission
- Ps = Cooling sensible emission
- Qw = Water flow
- Dp(c) = Water pressure drop
- Vdc = Inverter Power
- Qv = Air flow

Cooling emission of 4 row coil

Entering air temperature: 26°C – R.H.: 50%

MOD.	Vdc	Qv m ³ /h	WT: 7/12 °C				WT: 8/13 °C				WT: 10/15 °C				WT: 12/17 °C			
			Pc kW	Ps kW	Qw l/h	Dp(c) kPa	Pc kW	Ps kW	Qw l/h	Dp(c) kPa	Pc kW	Ps kW	Qw l/h	Dp(c) kPa	Pc kW	Ps kW	Qw l/h	Dp(c) kPa
SEC/F ECM 2.4	10	325	1,78	1,33	310	13,8	1,57	1,25	273	11,0	1,12	1,07	195	6,0	0,93	0,93	163	4,3
	7,5	260	1,51	1,12	262	10,2	1,33	1,04	232	8,2	0,95	0,89	166	4,5	0,78	0,78	136	3,1
	5	210	1,26	0,92	219	7,5	1,12	0,86	194	6,0	0,81	0,74	140	3,3	0,65	0,65	113	2,3
	3	160	1,02	0,74	176	5,1	0,90	0,69	157	4,1	0,65	0,59	114	2,3	0,51	0,51	90	1,5
	1	115	0,75	0,53	130	3,0	0,66	0,50	115	2,4	0,49	0,43	85	1,4	0,37	0,37	65	0,9
SEC/F ECM 4.4	10	505	3,05	2,24	528	15,1	2,69	2,09	467	12,1	1,94	1,79	338	6,8	1,57	1,57	274	4,6
	7,5	415	2,61	1,90	452	11,5	2,31	1,77	400	9,2	1,67	1,52	291	5,2	1,33	1,33	232	3,4
	5	340	2,18	1,57	376	8,3	1,93	1,47	334	6,7	1,41	1,26	244	3,8	1,10	1,10	191	2,4
	3	265	1,76	1,26	304	5,7	1,56	1,17	271	4,6	1,14	1,01	198	2,6	0,88	0,88	153	1,7
	1	200	1,38	0,98	238	3,7	1,23	0,91	212	3,0	0,90	0,78	156	1,7	0,68	0,68	119	1,1
SEC/F ECM 6.4	10	720	4,33	3,17	750	30,8	3,84	2,96	666	24,7	2,79	2,55	486	14,0	2,22	2,22	388	9,3
	7,5	590	3,69	2,67	638	23,1	3,27	2,50	567	18,6	2,39	2,15	415	10,6	1,87	1,87	326	6,9
	5	475	3,06	2,20	529	16,6	2,72	2,06	470	13,4	2,00	1,77	346	7,7	1,55	1,55	268	4,9
	3	375	2,50	1,78	431	11,6	2,22	1,66	384	9,4	1,64	1,43	283	5,4	1,25	1,25	217	3,3
	1	290	1,97	1,40	340	7,6	1,76	1,30	304	6,2	1,30	1,12	225	3,6	0,98	0,98	169	2,2
SEC/F ECM 7.4	10	875	5,09	3,75	883	23,9	4,51	3,51	782	19,2	3,27	3,02	569	10,8	2,63	2,63	459	7,3
	7,5	735	4,43	3,23	766	18,6	3,93	3,02	680	15,0	2,86	2,60	497	8,5	2,26	2,26	394	5,6
	5	585	3,67	2,66	635	13,4	3,26	2,48	565	10,8	2,39	2,13	414	6,2	1,87	1,87	325	4,0
	3	475	3,08	2,21	531	9,8	2,74	2,06	473	7,9	2,01	1,77	348	4,5	1,55	1,55	269	2,8
	1	380	2,51	1,79	434	6,8	2,24	1,67	387	5,6	1,65	1,44	286	3,2	1,26	1,26	217	2,0
SEC/F ECM 9.4	10	1365	6,74	5,18	1177	19,3	5,92	4,85	1035	15,3	4,30	4,30	757	8,7	3,59	3,59	635	6,3
	7,5	1145	5,93	4,50	1031	15,3	5,22	4,21	908	12,1	3,67	3,62	643	6,5	3,13	3,13	549	4,9
	5	910	4,99	3,74	866	11,2	4,40	3,50	764	8,9	3,12	3,00	544	4,9	2,60	2,60	454	3,5
	3	755	4,31	3,98	745	8,6	3,80	2,99	659	6,9	2,72	2,56	472	3,8	2,24	2,24	390	2,7
	1	575	3,45	2,53	597	5,8	3,05	2,36	528	4,7	2,20	2,02	382	2,6	1,77	1,77	307	1,7

Legend

- WT = Water temperature
 Pc = Cooling total emission
 Ps = Cooling sensible emission
 Qw = Water flow
 Dp(c) = Water pressure drop
 Vdc = Inverter Power
 Qv = Air flow

Cooling emission of 4 row coil

Entering air temperature: 25°C – R.H.: 50%

MOD.	Vdc	WT: 7/12 °C					WT: 8/13 °C					WT: 10/15 °C					WT: 12/17 °C				
		Qv m³/h	Pc kW	Ps kW	Qw l/h	Dp(c) kPa	Pc kW	Ps kW	Qw l/h	Dp(c) kPa	Pc kW	Ps kW	Qw l/h	Dp(c) kPa	Pc kW	Ps kW	Qw l/h	Dp(c) kPa			
SEC/F ECM 2.4	10	325	1,57	1,25	273	11,0	1,35	1,16	236	8,5	1,02	1,02	179	5,1	0,84	0,84	148	3,6			
	7,5	260	1,33	1,04	231	8,2	1,15	0,97	200	6,3	0,85	0,85	149	3,7	0,70	0,70	123	2,6			
	5	210	1,11	0,86	193	6,0	0,97	0,80	168	4,6	0,71	0,71	124	2,7	0,59	0,59	103	1,9			
	3	160	0,90	0,69	156	4,1	0,78	0,64	136	3,2	0,56	0,56	99	1,8	0,47	0,47	82	1,3			
	1	115	0,66	0,50	115	2,4	0,58	0,46	100	1,9	0,39	0,39	68	0,9	0,34	0,34	59	0,7			
SEC/F ECM 4.4	10	505	2,68	2,10	466	12,1	2,33	1,95	405	9,4	1,72	1,72	300	5,5	1,41	1,42	246	3,9			
	7,5	415	2,30	1,78	399	9,2	2,00	1,65	347	7,2	1,46	1,46	254	4,1	1,21	1,21	210	2,9			
	5	340	1,92	1,47	333	6,7	1,68	1,37	290	5,2	1,21	1,21	209	2,9	1,00	1,00	174	2,1			
	3	265	1,56	1,18	269	4,6	1,36	1,09	235	3,6	0,92	0,92	160	1,8	0,80	0,80	139	1,4			
	1	200	1,22	0,92	211	3,0	1,07	0,85	185	2,4	0,73	0,71	127	1,2	0,62	0,62	108	0,9			
SEC/F ECM 6.4	10	720	3,83	2,97	664	24,8	3,33	2,77	578	19,3	2,44	2,44	424	11,1	2,01	2,01	352	7,8			
	7,5	590	3,26	2,51	565	18,6	2,84	2,33	493	14,6	2,05	2,05	357	8,1	1,70	1,70	296	5,8			
	5	475	2,71	2,06	469	13,4	2,37	1,92	410	10,5	1,69	1,69	294	5,8	1,40	1,40	244	4,1			
	3	375	2,21	1,67	382	9,4	1,94	1,55	335	7,4	1,33	1,31	230	3,8	1,13	1,14	196	2,8			
	1	290	1,75	1,31	302	6,2	1,53	1,12	265	4,9	1,06	1,03	184	2,5	0,89	0,89	154	1,8			
SEC/F ECM 7.4	10	875	4,50	3,52	780	19,2	3,91	3,27	679	15,0	2,88	2,88	502	8,7	2,38	2,38	416	6,1			
	7,5	735	3,91	3,03	678	15,0	3,41	2,82	591	11,7	2,48	2,48	432	6,7	2,05	2,05	358	4,7			
	5	585	3,25	2,49	562	10,8	2,84	2,32	491	8,5	2,05	2,05	356	4,7	1,70	1,70	295	3,4			
	3	475	2,72	2,07	471	7,9	2,38	1,92	412	6,2	1,62	1,62	281	3,1	1,41	1,41	244	2,4			
	1	380	2,23	1,68	385	5,5	1,95	1,56	337	4,4	1,34	1,32	232	2,2	1,14	1,14	198	1,7			
SEC/F ECM 9.4	10	1365	5,91	4,86	1033	15,3	5,08	4,52	891	11,7	3,95	3,95	696	7,5	3,23	3,23	573	5,3			
	7,5	1145	5,20	4,22	906	12,2	4,49	3,93	783	9,3	3,44	3,44	603	5,8	2,82	2,82	497	4,1			
	5	910	4,39	3,50	762	9,0	3,79	3,26	659	6,9	2,86	2,86	498	4,2	2,35	2,35	411	2,9			
	3	755	3,79	2,99	657	6,9	3,28	2,78	569	5,3	2,46	2,46	427	3,2	2,03	2,03	353	2,2			
	1	575	3,04	2,37	526	4,7	2,64	2,20	457	3,6	1,94	1,94	336	2,1	1,60	1,60	278	1,5			

Legend

- WT = Water temperature
- Pc = Cooling total emission
- Ps = Cooling sensible emission
- Qw = Water flow
- Dp(c) = Water pressure drop
- Vdc = Inverter Power
- Qv = Air flow

Heating emission of 3 row coil

Entering air temperature: 26°C – R.H.: 50%

MOD.	Vdc	Qv m³/h	WT: 70/60 °C			WT: 60/50 °C			WT: 50/40 °C			WT: 50/45 °C			WT: 45/40 °C		
			Ph kW	Qw l/h	Dp(c) kPa	Ph kW	Qw l/h	Dp(c) kPa	Ph kW	Qw l/h	Dp(c) kPa	Ph kW	Qw l/h	Dp(c) kPa	Ph kW	Qw l/h	Dp(c) kPa
SEC/F ECM 2.3	10	330	3,64	313	6,7	2,78	239	4,3	1,92	165	2,3	2,22	383	10	1,80	309	7,0
	7,5	270	3,09	265	5,0	2,36	203	3,2	1,63	140	1,7	1,89	324	7,5	1,52	262	5,2
	5	220	2,61	224	3,7	1,99	171	2,4	1,38	119	1,3	1,59	274	5,6	1,29	222	3,9
	3	170	2,10	181	2,5	1,61	138	1,6	1,12	96	0,9	1,28	221	3,8	1,04	179	2,7
	1	120	1,55	133	1,5	1,19	102	1,0	0,83	71	0,5	0,95	163	2,2	0,77	132	1,6
SEC/F ECM 4.3	10	515	6,33	544	25,2	4,86	418	16,3	3,39	291	8,9	3,87	665	37,9	3,14	540	26,7
	7,5	430	5,43	467	19,2	4,17	359	12,5	2,91	250	6,8	3,32	571	28,9	2,69	463	20,4
	5	350	4,55	391	14,1	3,50	301	9,1	2,44	210	5,0	2,78	478	21,2	2,26	388	14,9
	3	280	3,70	318	9,8	2,85	245	6,4	1,99	171	3,5	2,26	389	14,7	1,84	316	10,4
	1	210	2,85	245	6,2	2,20	189	4,0	1,54	133	2,2	1,74	300	9,3	1,42	244	6,6
SEC/F ECM 6.3	10	735	8,37	719	16	6,41	551	10,3	4,45	383	5,6	5,11	879	24,1	4,14	712	17
	7,5	610	7,17	616	12,2	5,50	473	7,9	3,82	329	4,3	4,38	753	18,4	3,55	610	12,9
	5	495	6,04	520	9,0	4,64	399	5,9	3,23	278	3,2	3,69	635	13,6	3,00	515	9,6
	3	395	4,97	427	6,4	3,82	328	4,2	2,66	229	2,3	3,03	522	9,6	2,46	424	6,8
	1	305	3,95	339	4,3	3,04	261	2,8	2,12	182	1,5	2,41	415	6,4	1,96	337	4,5
SEC/F ECM 7.3	10	890	10,25	882	26,7	7,87	677	17,3	5,49	472	9,5	6,26	1077	40,1	5,08	874	28,3
	7,5	755	8,94	769	21	6,87	591	13,6	4,79	412	7,5	5,46	939	31,5	4,43	762	22,2
	5	610	7,50	645	15,4	5,77	496	10	4,03	347	5,5	4,58	788	23,2	3,72	640	16,4
	3	500	6,30	542	11,3	4,85	417	7,4	3,93	338	4,1	3,85	662	17	3,13	538	12,1
	1	400	5,16	444	8,0	3,98	342	5,2	2,79	240	2,9	3,15	542	12	2,56	441	8,5
SEC/F ECM 9.3	10	1395	14,95	1285	22,9	11,42	982	14,7	7,90	679	8,0	9,13	1570	34,5	7,38	1270	24,2
	7,5	1175	13,06	1123	18,1	9,99	859	11,6	6,92	595	6,3	7,98	1372	27,2	6,46	1111	19,1
	5	945	10,94	941	13,2	8,38	720	8,5	5,81	500	4,6	6,68	1149	19,9	5,41	931	14
	3	785	9,40	809	10,1	7,21	620	6,5	5,00	430	3,6	5,74	988	15,3	4,66	801	10,7
	1	605	7,55	649	6,9	5,79	498	4,5	4,03	347	2,4	4,61	793	10,4	3,74	643	7,3

Legend

- WT = Water temperature
- Pc = Cooling total emission
- Ps = Cooling sensible emission
- Qw = Water flow
- Dp(c) = Water pressure drop
- Vdc = Inverter Power
- Qv = Air flow

Heating emission of 4 row coil

Entering air temperature: 25°C – R.H.: 50%

MOD.	Vdc	WT: 70/60 °C				WT: 60/50 °C			WT: 50/40 °C			WT: 50/45 °C			WT: 45/40 °C		
		Qv m³/h	Ph kW	Qw l/h	Dp(c) kPa	Ph kW	Qw l/h	Dp(c) kPa	Ph kW	Qw l/h	Dp(c) kPa	Ph kW	Qw l/h	Dp(c) kPa	Ph kW	Qw l/h	Dp(c) kPa
SEC/F ECM 2.4	10	325	4,01	344	12,9	3,07	264	8,3	2,14	184	4,5	2,45	421	19,4	1,98	341	13,6
	7,5	260	3,33	286	9,3	2,56	220	6,0	1,78	153	3,3	2,03	350	14	1,65	284	9,9
	5	210	2,75	237	6,7	2,12	182	4,3	1,48	127	2,4	1,68	289	10	1,37	235	7,1
	3	160	2,18	187	4,4	1,68	144	2,9	1,17	101	1,6	1,33	229	6,6	1,08	186	4,7
	1	115	1,57	135	2,5	1,21	104	1,6	0,85	73	0,9	0,96	165	3,7	0,78	134	2,6
SEC/F ECM 4.4	10	505	6,60	568	12,9	5,07	436	8,4	3,54	304	4,6	4,04	694	19,5	3,28	563	13,7
	7,5	415	5,57	479	9,6	4,29	369	6,2	3,00	258	3,4	3,41	586	14,5	2,77	476	10,2
	5	340	4,59	394	6,8	3,53	304	4,4	2,48	213	2,5	2,81	484	10,3	2,29	394	7,3
	3	265	3,67	316	4,6	2,83	243	3,0	1,99	171	1,7	2,24	386	6,9	1,83	314	4,9
	1	200	2,83	244	2,9	2,19	188	1,9	1,54	132	1,1	1,73	298	4,4	1,41	243	3,1
SEC/F ECM 6.4	10	720	9,43	811	27,4	7,26	624	17,8	5,08	437	9,8	5,76	991	41,2	4,68	805	29,1
	7,5	590	7,90	679	20,1	6,09	523	13,1	4,27	367	7,2	4,83	830	30,2	3,93	675	21,4
	5	475	6,48	557	14,2	5,00	430	9,2	3,51	302	5,1	3,96	681	21,3	3,23	555	15,1
	3	375	5,21	448	9,6	4,02	346	6,3	2,83	243	3,5	3,19	548	14,5	2,59	446	10,3
	1	290	4,05	348	6,2	3,13	269	4,1	2,21	190	2,3	2,48	426	9,3	2,02	347	6,6
SEC/F ECM 7.4	10	875	10,93	940	20,7	8,41	723	13,5	5,88	505	7,4	6,68	1149	31,2	5,43	933	22
	7,5	735	9,39	808	15,9	7,23	622	10,3	5,06	435	5,7	5,74	987	23,9	4,66	802	16,9
	5	585	7,73	664	11,3	5,95	512	7,3	4,17	359	4,1	4,72	812	16,9	3,84	660	12
	3	475	6,38	549	8,0	4,92	423	5,2	3,45	297	2,9	3,90	671	12,1	3,17	546	8,6
	1	380	5,16	444	5,5	3,98	342	3,6	2,80	241	2,0	3,15	542	8,3	2,57	442	5,9
SEC/F ECM 9.4	10	1365	16,03	1379	19,8	12,27	1055	12,8	8,50	731	6,9	9,79	1685	29,8	7,93	1364	20,9
	7,5	1145	13,82	1188	15,2	10,58	910	9,8	7,35	632	5,3	8,44	1452	22,9	6,84	1176	16,1
	5	910	11,37	978	10,8	8,72	750	7,0	6,06	521	3,8	6,94	1194	16,3	5,63	969	11,4
	3	755	9,69	834	8,2	7,44	640	5,3	5,18	446	2,9	5,92	1019	12,3	4,81	826	8,7
	1	575	7,58	652	5,3	5,82	501	3,4	4,07	350	1,9	4,63	796	8,0	3,76	647	5,6

Legend

- WT = Water temperature
- Pc = Cooling total emission
- Ps = Cooling sensible emission
- Qw = Water flow
- Dp(c) = Water pressure drop
- Vdc = Inverter Power
- Qv = Air flow

Heating emission of 1 additional row coil

Entering air temperature: 20°C

MOD.	Vdc	Qv m³/h	WT: 80/70 °C			WT: 75/65 °C			WT: 70/60 °C			WT: 65/55 °C			WT: 60/50 °C			WT: 55/45 °C		
			Ph kW	Qw l/h	Dp(c) kPa	Ph kW	Qw l/h	Dp(c) kPa	Ph kW	Qw l/h	Dp(c) kPa	Ph kW	Qw l/h	Dp(c) kPa	Ph kW	Qw l/h	Dp(c) kPa	Ph kW	Qw l/h	Dp(c) kPa
SEC/F ECM 2	10	330	2,04	176	6,3	1,84	158	5,3	1,63	140	4,3	1,43	123	3,5	1,22	105	2,7	1,018	88	2,0
	7,5	270	1,78	153	4,9	1,60	138	4,1	1,42	122	3,4	1,24	107	2,7	1,07	92	2,1	0,888	76	1,6
	5	220	1,54	132	3,8	1,38	119	3,2	1,23	106	2,6	1,08	93	2,1	0,92	79	1,6	0,77	66	1,2
	3	170	1,29	111	2,8	1,16	100	2,4	1,04	89	1,9	0,91	78	1,6	0,78	67	1,2	0,65	56	0,9
	1	120	1,02	87	1,8	0,92	79	1,5	0,81	70	1,3	0,71	61	1,0	0,61	53	0,8	0,512	44	0,6
SEC/F ECM 4	10	515	3,41	293	19,4	3,08	264	16,4	2,74	236	13,6	2,41	207	11	2,07	178	8,6	1,74	150	6,4
	7,5	430	3,01	259	15,6	2,72	234	13,2	2,42	208	10,9	2,13	183	8,8	1,83	158	6,9	1,54	132	5,2
	5	350	2,62	225	12,2	2,36	203	10,3	2,11	181	8,5	1,85	159	6,9	1,60	137	5,4	1,34	115	4,0
	3	280	2,22	191	9,1	2,01	172	7,7	1,79	154	6,4	1,57	135	5,2	1,36	117	4,1	1,139	98	3,0
	1	210	1,82	157	6,4	1,64	141	5,4	1,47	126	4,5	1,29	111	3,6	1,11	96	2,9	0,935	80	2,1
SEC/F ECM 6	10	735	4,61	396	6,4	4,14	356	5,4	3,68	317	4,5	3,22	277	3,6	2,76	238	2,8	2,303	198	2,0
	7,5	610	4,05	348	5,1	3,64	313	4,3	3,24	278	3,6	2,83	244	2,9	2,43	209	2,2	2,029	174	1,6
	5	495	3,50	301	4,0	3,15	271	3,3	2,80	241	2,8	2,45	211	2,2	2,11	181	1,7	1,76	151	1,3
	3	395	3,00	258	3,0	2,70	232	2,5	2,40	206	2,1	2,10	181	1,7	1,81	155	1,3	1,509	130	1,0
	1	305	2,50	215	2,2	2,25	194	1,9	2,00	172	1,5	1,76	151	1,2	1,51	130	1,0	1,263	109	0,7
SEC/F ECM 7	10	890	5,77	496	11,2	5,20	447	9,5	4,63	398	7,8	4,06	349	6,3	3,50	301	4,9	2,929	252	3,7
	7,5	755	5,15	443	9,2	4,64	399	7,8	4,13	355	6,4	3,63	312	5,2	3,12	268	4,0	2,616	225	3,0
	5	610	4,43	381	7,1	4,00	344	6,0	3,56	306	4,9	3,13	269	4,0	2,69	231	3,1	2,258	194	2,3
	3	500	3,86	332	5,5	3,48	299	4,7	3,10	267	3,9	2,72	234	3,1	2,35	202	2,4	1,969	169	1,8
	1	400	3,30	284	4,2	2,97	256	3,5	2,65	228	2,9	2,33	200	2,4	2,01	173	1,9	1,685	145	1,4
SEC/F ECM 9	10	1395	7,46	641	17,6	6,72	578	14,9	5,98	514	12,3	5,24	451	9,9	4,51	388	7,7	3,772	324	5,7
	7,5	1175	6,67	574	14,5	6,01	517	12,2	5,35	460	10,1	4,69	404	8,2	4,04	347	6,4	3,379	291	4,7
	5	945	5,75	495	11,2	5,18	446	9,4	4,62	397	7,8	4,05	348	6,3	3,48	300	4,9	2,919	251	3,7
	3	785	5,08	437	9,0	4,58	394	7,6	4,08	351	6,3	3,58	308	5,1	3,08	265	3,9	2,582	222	2,9
	1	605	4,23	364	6,5	3,82	328	5,5	3,40	292	4,6	2,99	257	3,7	2,57	221	2,9	2,158	186	2,1

Legend

- WT = Water temperature
- Pc = Cooling total emission
- Ps = Cooling sensible emission
- Qw = Water flow
- Dp(c) = Water pressure drop
- Vdc = Inverter Power
- Qv = Air flow

Heating emission of 2 additional row coil

Entering air temperature: 20°C

MOD.	Vdc	WT: 65/55 °C			WT: 60/50 °C			WT: 55/45 °C			WT: 50/40 °C			WT: 45/40 °C			WT: 45/35 °C			
		Qv	Ph	Qw	Dp(c)	Ph	Qw	Dp(c)	Ph	Qw	Dp(c)	Ph	Qw	Dp(c)	Ph	Qw	Dp(c)	Ph	Qw	Dp(c)
		m³/h	kW	l/h	kPa	kW	l/h	kPa	kW	l/h	kPa	kW	l/h	kPa	kW	l/h	kPa	kW	l/h	kPa
SEC/F ECM 2	10	330	2,48	214	16,7	2,15	184	13,1	1,81	155	9,9	1,47	126	7,0	1,39	239	21,6	1,13	97	4,5
	7,5	270	2,13	183	12,7	1,84	158	10	1,55	133	7,5	1,26	109	5,3	1,19	205	16,5	0,97	84	3,4
	5	220	1,81	155	9,6	1,56	134	7,5	1,32	113	5,7	1,07	92	4,0	1,01	174	12,4	0,83	71	2,6
	3	170	1,49	128	6,8	1,29	111	5,3	1,10	94	4,1	0,89	77	2,9	0,84	144	8,9	0,69	59	1,9
	1	120	1,13	97	4,2	0,98	84	3,3	0,83	71	2,5	0,68	58	1,8	0,63	109	5,4	0,52	45	1,2
SEC/F ECM 4	10	515	3,90	335	7,6	3,36	289	5,9	2,82	243	4,4	2,29	197	3,1	2,18	375	9,8	1,76	151	2,0
	7,5	430	3,40	292	5,9	2,93	252	4,7	2,47	212	3,5	2,00	172	2,5	1,90	327	7,7	1,54	132	1,6
	5	350	2,90	249	4,5	2,50	215	3,5	2,11	181	2,6	1,71	147	1,9	1,62	279	5,8	1,32	113	1,2
	3	280	2,43	209	3,3	2,10	181	2,6	1,77	152	1,9	1,44	124	1,4	1,36	234	4,3	1,11	95	0,9
	1	210	1,94	166	2,2	1,67	144	1,7	1,41	121	1,3	1,15	99	0,9	1,08	186	2,8	0,89	76	0,6
SEC/F ECM 6	10	735	5,63	484	17,8	4,87	419	14	4,11	353	10,5	3,35	288	7,5	3,15	542	23	2,59	223	4,9
	7,5	610	4,88	419	13,8	4,22	363	10,9	3,56	306	8,2	2,91	250	5,8	2,73	470	17,9	2,25	194	3,8
	5	495	4,14	356	10,3	3,58	308	8,1	3,03	260	6,2	2,47	213	4,4	2,32	398	13,4	1,92	165	2,9
	3	395	3,46	297	7,5	3,00	258	5,9	2,53	218	4,5	2,09	180	3,3	1,96	336	9,9	1,62	139	2,1
	1	305	2,83	243	5,3	2,45	211	4,2	2,08	178	3,2	1,70	146	2,3	1,58	272	6,9	1,32	113	1,5
SEC/F ECM 7	10	890	7,01	603	31,1	6,07	522	24,5	5,14	442	18,6	4,20	361	13,3	3,93	675	40,2	3,27	281	8,7
	7,5	755	6,17	530	24,8	5,34	460	19,6	4,52	389	14,8	3,70	318	10,6	3,45	594	32,1	2,88	248	6,9
	5	610	5,20	447	18,4	4,51	388	14,5	3,82	328	11	3,13	269	7,9	2,91	501	23,8	2,44	209	5,2
	3	500	4,47	384	14,1	3,88	333	11,1	3,28	282	8,4	2,69	232	6,1	2,50	431	18,2	2,10	180	4,0
	1	400	3,72	320	10,2	3,23	277	8,1	2,74	235	6,1	2,24	193	4,4	2,08	358	13,2	1,75	151	2,9
SEC/F ECM 9	10	1395	9,60	825	54	8,31	714	42,6	7,02	604	32,2	5,74	493	22,9	-	-	-	4,45	383	15
	7,5	1175	8,49	730	43,5	7,35	632	34,3	6,22	535	26	5,08	437	18,5	-	-	-	3,94	339	12,1
	5	945	7,22	621	32,7	6,25	538	25,8	5,29	455	19,5	4,33	372	14	-	-	-	3,36	289	9,1
	3	785	6,28	540	25,6	5,45	468	20,2	4,61	396	15,3	3,77	324	11	-	-	-	2,93	252	7,2
	1	605	5,12	440	17,8	4,44	381	14,1	3,76	323	10,7	3,08	265	7,7	-	-	-	2,40	206	5,0

Legend

- WT = Water temperature
- Pc = Cooling total emission
- Ps = Cooling sensible emission
- Qw = Water flow
- Dp(c) = Water pressure drop
- Vdc = Inverter Power
- Qv = Air flow

**Air flow and correction factors for emission
with different available pressures**

MOD.	Vdc	Qv (m³/h)									K1									K2									
		Ap (Pa)									Ap (Pa)									Ap (Pa)									
		0	5	10	15	20	25	30	35	40	0	5	10	15	20	25	30	35	40	0	5	10	15	20	25	30	35	40	
SEC/F ECM 2	10	330	312	288	257	223	171	88	-	-	1,00	0,95	0,89	0,82	0,73	0,60	0,32	-	-	-	0,95	0,88	0,80	0,72	0,58	0,29	-	-	
	8,5	307	276	251	213	162	92	29	-	-	1,00	0,91	0,85	0,75	0,61	0,36	0,06	-	-	-	1,00	0,90	0,83	0,73	0,59	0,34	0,03	-	-
	7,5	270	252	219	178	103	-	-	-	-	1,00	0,94	0,84	0,72	0,46	-	-	-	-	-	1,00	0,94	0,83	0,70	0,44	-	-	-	-
	6,5	248	227	187	130	56	-	-	-	-	1,00	0,93	0,80	0,60	0,26	-	-	-	-	-	1,00	0,92	0,78	0,58	0,24	-	-	-	-
	5	220	187	126	55	-	-	-	-	-	1,00	0,88	0,65	0,30	-	-	-	-	-	-	1,00	0,86	0,63	0,27	-	-	-	-	-
	3	170	122	45	-	-	-	-	-	-	1,00	0,77	0,32	-	-	-	-	-	-	-	1,00	0,75	0,29	-	-	-	-	-	-
	2	144	82	-	-	-	-	-	-	-	1,00	0,65	-	-	-	-	-	-	-	-	1,00	0,63	-	-	-	-	-	-	-
1	120	68	-	-	-	-	-	-	-	1,00	0,64	-	-	-	-	-	-	-	-	1,00	0,62	-	-	-	-	-	-	-	
SEC/F ECM 4	10	515	499	477	448	401	332	247	100	-	1,00	0,97	0,94	0,89	0,82	0,71	0,56	0,22	-	-	0,97	0,93	0,88	0,80	0,69	0,54	0,19	-	
	8,5	459	444	419	377	323	229	54	-	-	1,00	0,97	0,93	0,85	0,76	0,58	0,10	-	-	1,00	0,97	0,92	0,84	0,74	0,56	0,07	-	-	
	7,5	430	396	363	320	240	89	-	-	-	1,00	0,93	0,87	0,79	0,63	0,24	-	-	-	1,00	0,92	0,86	0,77	0,61	0,21	-	-	-	
	6,5	394	374	333	272	135	-	-	-	-	1,00	0,95	0,87	0,74	0,41	-	-	-	-	1,00	0,95	0,86	0,73	0,39	-	-	-	-	
	5	350	308	255	107	-	-	-	-	-	1,00	0,90	0,78	0,37	-	-	-	-	-	1,00	0,89	0,76	0,35	-	-	-	-	-	
	3	280	227	99	-	-	-	-	-	-	1,00	0,84	0,43	-	-	-	-	-	-	1,00	0,83	0,41	-	-	-	-	-	-	
	2	233	170	-	-	-	-	-	-	-	1,00	0,78	-	-	-	-	-	-	-	1,00	0,76	-	-	-	-	-	-	-	
1	210	126	-	-	-	-	-	-	-	1,00	0,67	-	-	-	-	-	-	-	1,00	0,65	-	-	-	-	-	-	-		
SEC/F ECM 6	10	735	696	673	622	558	431	286	168	-	1,00	0,95	0,93	0,87	0,80	0,66	0,47	0,27	-	-	0,95	0,92	0,86	0,78	0,64	0,45	0,24	-	
	8,5	650	628	583	525	421	269	110	-	-	1,00	0,97	0,91	0,84	0,71	0,49	0,18	-	-	1,00	0,97	0,90	0,82	0,69	0,47	0,15	-	-	
	7,5	610	564	528	437	284	129	-	-	-	1,00	0,94	0,89	0,77	0,55	0,25	-	-	-	1,00	0,93	0,87	0,75	0,53	0,22	-	-	-	
	6,5	558	510	457	340	189	-	-	-	-	1,00	0,93	0,85	0,68	0,41	-	-	-	-	1,00	0,92	0,83	0,66	0,39	-	-	-	-	
	5	495	432	352	154	-	-	-	-	-	1,00	0,89	0,76	0,38	-	-	-	-	-	1,00	0,88	0,74	0,36	-	-	-	-	-	
	3	395	319	151	82	-	-	-	-	-	1,00	0,84	0,46	0,24	-	-	-	-	-	1,00	0,82	0,44	0,21	-	-	-	-	-	
	2	351	221	-	-	-	-	-	-	-	1,00	0,70	-	-	-	-	-	-	-	1,00	0,68	-	-	-	-	-	-	-	
1	305	177	-	-	-	-	-	-	-	1,00	0,65	-	-	-	-	-	-	-	1,00	0,63	-	-	-	-	-	-	-		
SEC/F ECM 7	10	890	846	815	756	699	590	486	341	191	1,00	0,96	0,93	0,87	0,82	0,72	0,62	0,46	0,25	-	0,95	0,92	0,86	0,81	0,70	0,60	0,44	0,22	
	8,5	805	756	703	652	560	437	279	114	-	1,00	0,95	0,89	0,84	0,75	0,62	0,42	0,14	-	1,00	0,94	0,88	0,83	0,73	0,60	0,40	0,11	-	
	7,5	755	696	637	558	459	300	140	-	-	1,00	0,93	0,87	0,79	0,68	0,48	0,21	-	-	1,00	0,93	0,86	0,77	0,66	0,46	0,18	-	-	
	6,5	703	637	560	449	336	175	-	-	-	1,00	0,92	0,83	0,70	0,56	0,30	-	-	-	1,00	0,91	0,82	0,68	0,54	0,27	-	-	-	
	5	610	532	443	313	133	-	-	-	-	1,00	0,89	0,78	0,59	0,26	-	-	-	-	1,00	0,88	0,76	0,57	0,23	-	-	-	-	
	3	500	398	255	83	-	-	-	-	-	1,00	0,83	0,59	0,18	-	-	-	-	-	1,00	0,81	0,57	0,15	-	-	-	-	-	
	2	452	348	178	-	-	-	-	-	-	1,00	0,81	0,47	-	-	-	-	-	-	1,00	0,79	0,45	-	-	-	-	-	-	
1	400	279	-	-	-	-	-	-	-	1,00	0,75	-	-	-	-	-	-	-	1,00	0,73	-	-	-	-	-	-	-		
SEC/F ECM 9	10	1395	1310	1225	1180	1125	1060	1000	930	860	1,00	0,95	0,90	0,87	0,84	0,80	0,77	0,73	0,68	-	0,94	0,89	0,86	0,82	0,78	0,75	0,71	0,66	
	8,5	1265	1175	1080	1020	960	880	800	720	640	1,00	0,94	0,88	0,84	0,80	0,75	0,70	0,64	0,59	1,00	0,93	0,86	0,82	0,78	0,73	0,68	0,62	0,57	
	7,5	1175	1075	970	910	840	750	650	545	450	1,00	0,93	0,85	0,81	0,77	0,70	0,63	0,54	0,46	1,00	0,92	0,84	0,80	0,75	0,68	0,61	0,52	0,44	
	6,5	1085	980	865	790	700	605	500	350	200	1,00	0,92	0,83	0,78	0,71	0,63	0,54	0,39	0,21	1,00	0,91	0,82	0,76	0,69	0,61	0,52	0,37	0,18	
	5	945	835	680	580	460	315	160	-	-	1,00	0,90	0,77	0,68	0,57	0,40	0,18	-	-	1,00	0,89	0,75	0,66	0,55	0,38	0,15	-	-	
	3	785	620	400	230	50	-	-	-	-	1,00	0,83	0,59	0,35	-	-	-	-	-	1,00	0,81	0,57	0,33	-	-	-	-	-	
	2	700	500	200	-	-	-	-	-	-	1,00	0,77	0,34	-	-	-	-	-	-	1,00	0,75	0,32	-	-	-	-	-	-	
1	605	390	-	-	-	-	-	-	-	1,00	0,71	-	-	-	-	-	-	-	1,00	0,69	-	-	-	-	-	-	-		

Legend

- Qv = Air flow
- K1 = Correction factors for Total cooling emission
- K2 = Correction factors for Sensible cooling emission and Heating emission
- Ap = Available pressure
- Vdc = Inverter Power

3 row coil

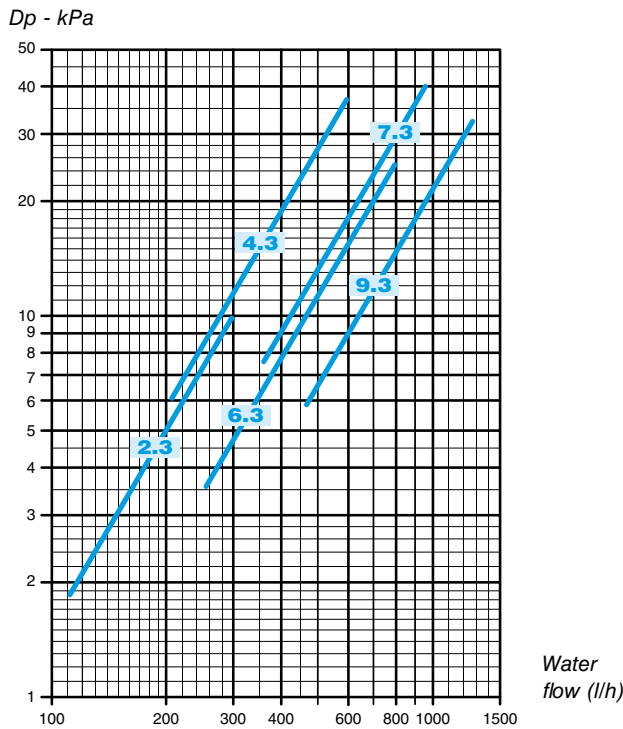

The water pressure drop figures refer to a mean water temperature of **10°C**; for different temperatures, multiply the pressure drop figures by the correction factors **K**.

4 row coil

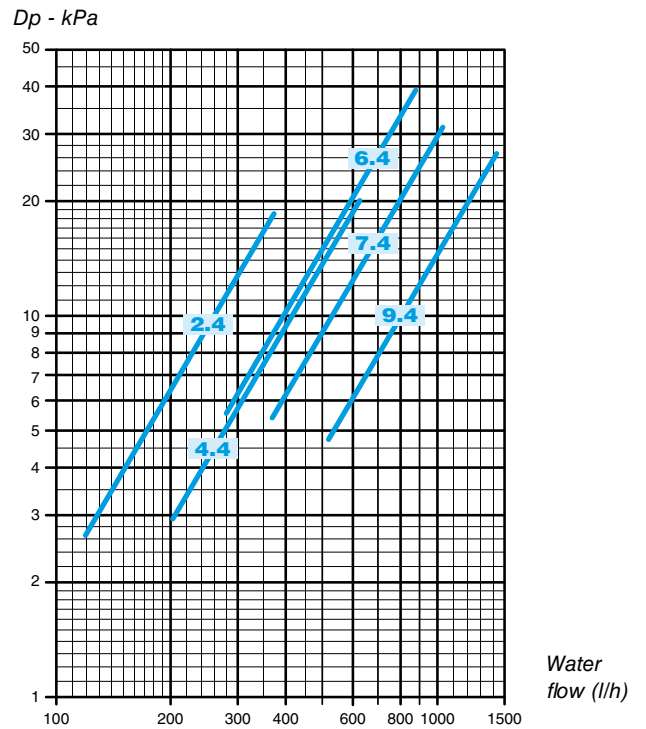

°C	20	30	40	50	60	70	80
K	0,94	0,90	0,86	0,82	0,78	0,74	0,70

1 row additional coil

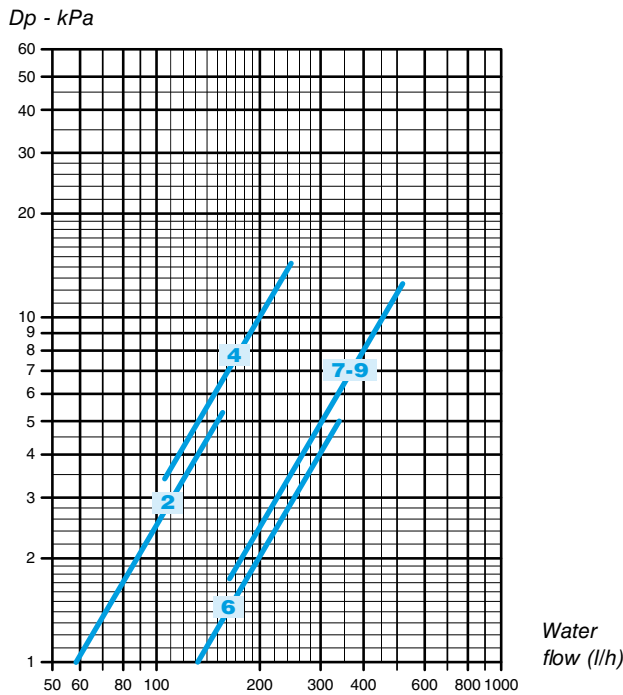

The water pressure drop figures refer to a mean water temperature of **60°C**; for different temperatures, multiply the pressure drop figures by the correction factors **K**.

2 row additional coil

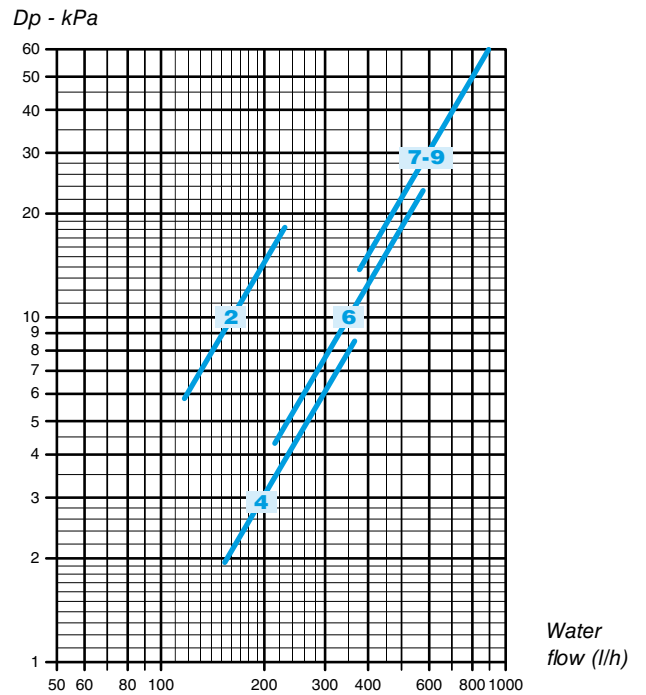

°C	40	50	70	80
K	1,12	1,06	0,94	0,88

VBP
main coil 3 way valve

Control valve kit:
3 way valve, ON-OFF,
with electric motor and mounting kit
with micrometric lockshield valve.

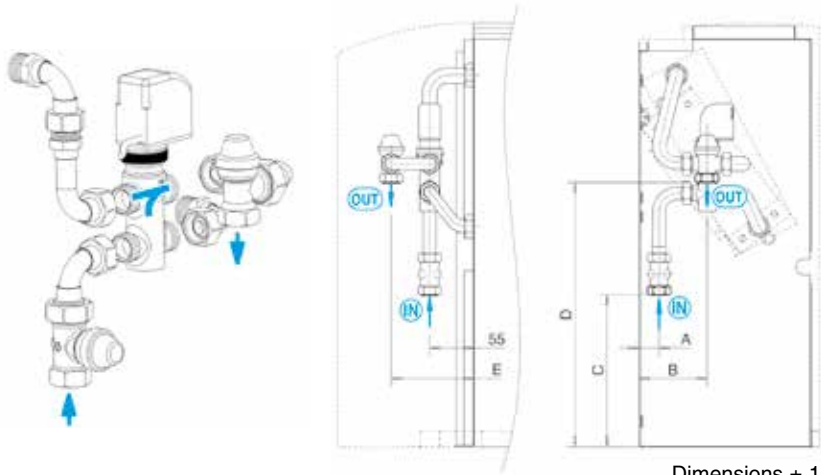

Dimensions ± 10 mm

Version	SEC/F-ECM
MODEL	CV - CH - CVB - NC

MOD.	Dimensions (mm)					Valve			Micrometric lockshield valve			Code	
	SEC/F	A	B	C	D	E	DN	(Ø)	Kvs	DN	(Ø)	Kvs	FITTED
2 - 4	25	85	190	290	105	15	1/2"	1,6	15	1/2" F	2	9066561H	9066560H
6 - 7	25	85	190	290	105	20	3/4"	2,5	15	1/2" F	2	9060471H	9060474H
9	50	120	185	290	105	20	3/4"	2,5	15	1/2" F	2	9060471H	9060474H

VBA
additional coil 3 way valve

Control valve kit:
3 way valve, ON-OFF,
with electric motor and mounting kit
with micrometric lockshield valve.

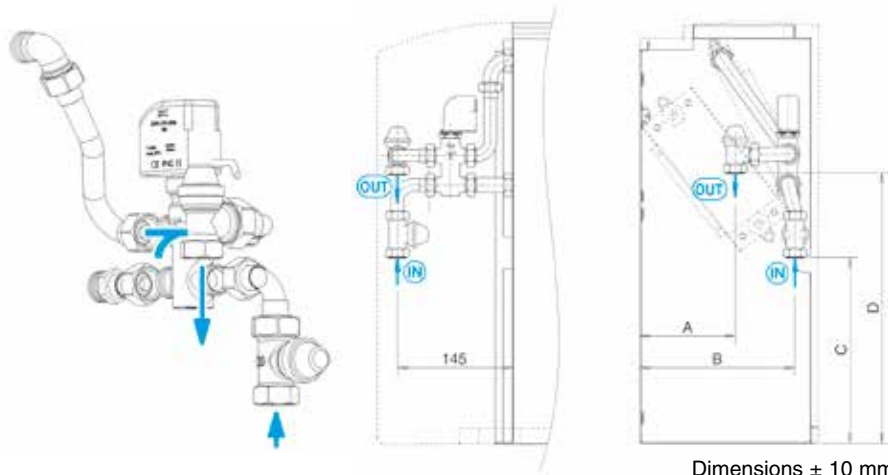

Dimensions ± 10 mm

Version	SEC/F-ECM
MODEL	CV - CH - CVB - NC

MOD.	Dimensions (mm)					Valve			Micrometric lockshield valve			Code	
	SEC/F	A	B	C	D	DN	(Ø)	Kvs	DN	(Ø)	Kvs	FITTED	NOT FITTED
2 ÷ 7	120	195	240	340	15	1/2"	1,6	15	1/2" F	2	9060472H	9060475H	
9	135	200	235	330	15	1/2"	1,6	15	1/2" F	2	9060472H	9060475H	

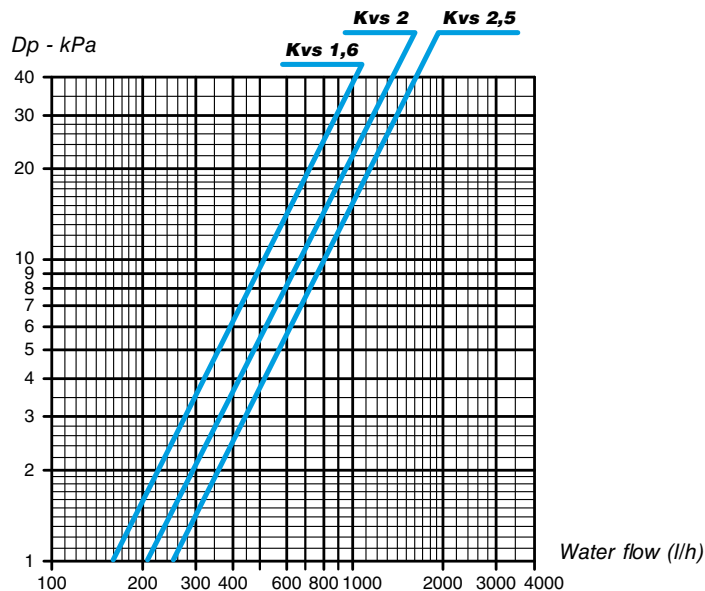

VS
simplified kit for 3 way valve
(concealed model only)

3 way valve, (ON-OFF)
with electric motor and mounting kit.
Valve with flat connection
without micrometric lockshield valve.

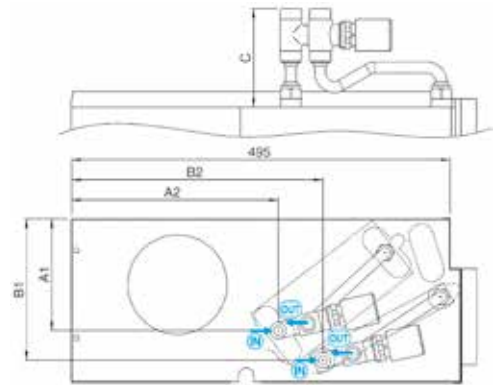
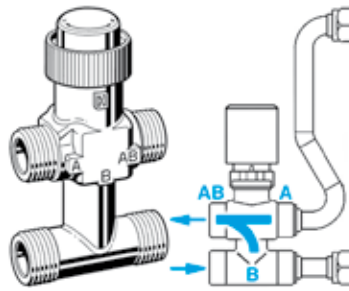

Dimensions ± 10 mm

Version	SEC/F-ECM
MODEL	NC

MOD.	Dimensions (mm)					MAIN					ADDITIONAL					
	MAIN		ADDITIONAL			C	Valve			Code		DN	(Ø)	Kvs	FITTED	NOT FITTED
	A1	A2	B1	B2	DN		(Ø)	Kvs	FITTED	NOT FITTED						
SEC/F	A1	A2	B1	B2	C	DN	(Ø)	Kvs	FITTED	NOT FITTED	DN	(Ø)	Kvs	FITTED	NOT FITTED	
2 - 4	152	270	185	330	116	15	1/2"	1,6	9066571H	9066570H	15	1/2"	1,6	9060483H	9060480H	
6 - 7	152	268	185	330	124	20	3/4"	2,5	9060484H	9060481H						
9	177	270	210	327	124	20	3/4"	2,5	9060484H	9060481H						

V2
2 way valve
for main and additional coil

Control valve kit:
2 way valve, ON-OFF,
with electric motor and mounting kit.

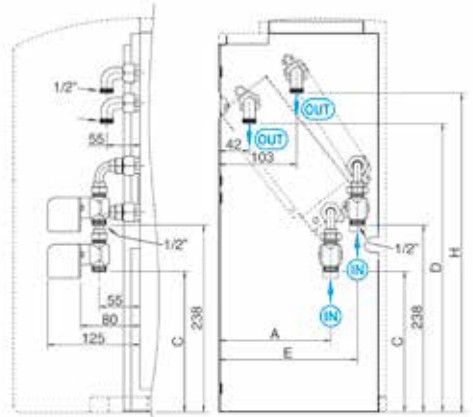
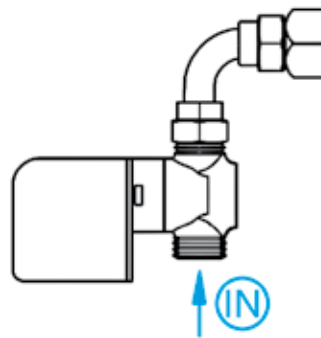

Dimensions ± 10 mm

Version	SEC/F-ECM
MODEL	CV - CH - CVB - NC

MOD.	Dimensions (mm)					MAIN					ADDITIONAL					
	MAIN		ADDITIONAL			C	Valve			Code		DN	(Ø)	Kvs	FITTED	NOT FITTED
	A1	A2	B1	B2	DN		(Ø)	Kvs	FITTED	NOT FITTED						
SEC/F	A1	A2	B1	B2	C	DN	(Ø)	Kvs	FITTED	NOT FITTED	DN	(Ø)	Kvs	FITTED	NOT FITTED	
2 - 4	149	180	438	186	456	15	1/2"	1,7	9066573H	9066575H	15	1/2"	1,7	9066573H	9066575H	
6 - 7	150	181	438	186	456	20	3/4"	2,8	9066574H	9066576H						
9	176	175	422	210	440	20	3/4"	2,8	9066574H	9066576H						

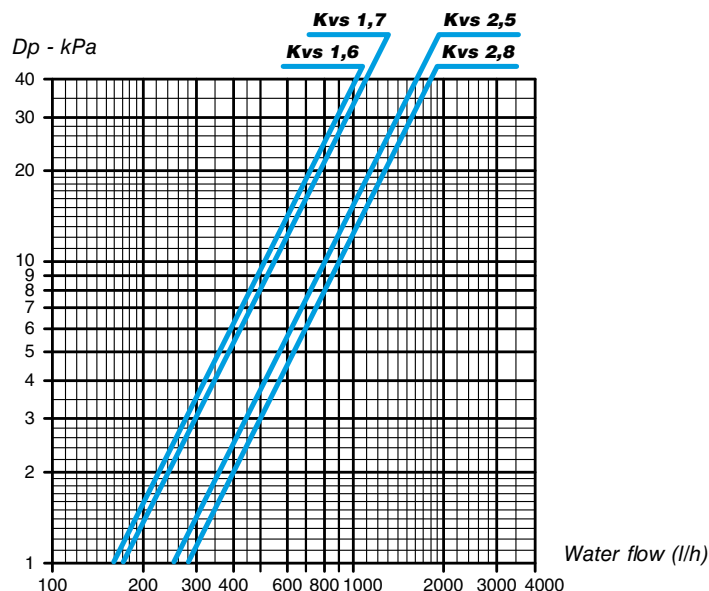

3 way double valve kit for 4 tube installation and single coil

The kit consists of:

- 2 special 3 way valves;
- 2 230 Volt ON-OFF actuators with internal safety micro switch;
- insulated pipe kit;
- external valve insulation sleeve.

Version	SEC/F-ECM
MODEL	CV - CH - CVB - NC

MOD.	(Ø)	Kvs	FITTED		NOT FITTED	
			CODE	TYPE	CODE	TYPE
SEC/F						
1 ÷ 9	3/4"	2,2	9066572W	V3M4X2	9066562W	V3S4X2

The kit uses a special 3 way valve which allows the transformation of the fan coil, equipped with one single coil, into a 4 tube installation.

The new **4X2** valve has been designed to keep the water flow between flow and return perfectly separated, allowing its use in parallel. Therefore, it can be used on 4 pipe fan coil systems with one single heat-exchange coil on board the fan coil.

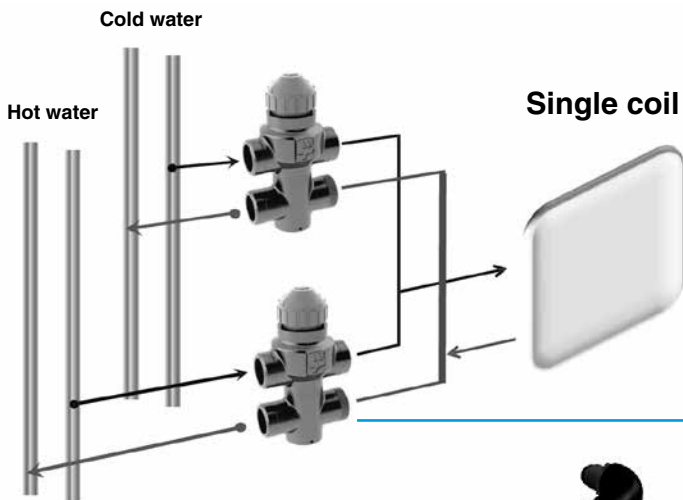
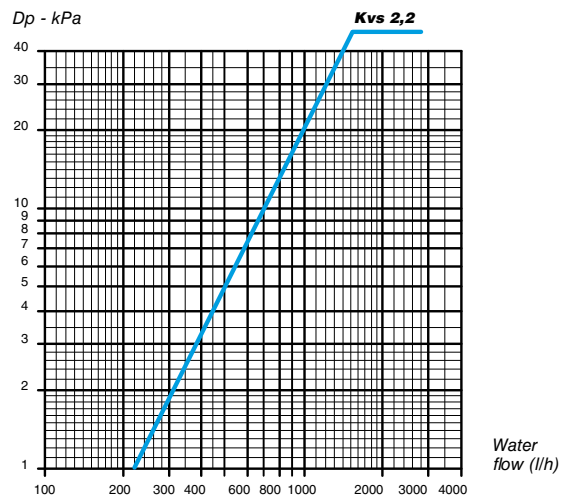

Double actuator electrical connections

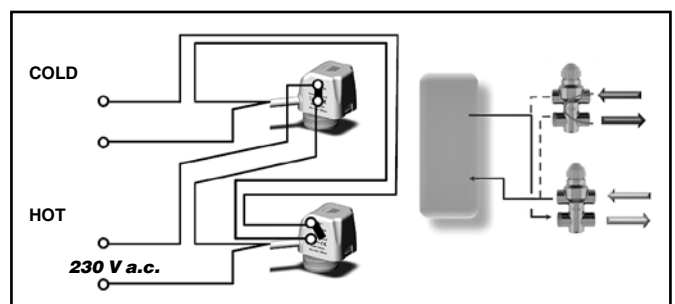
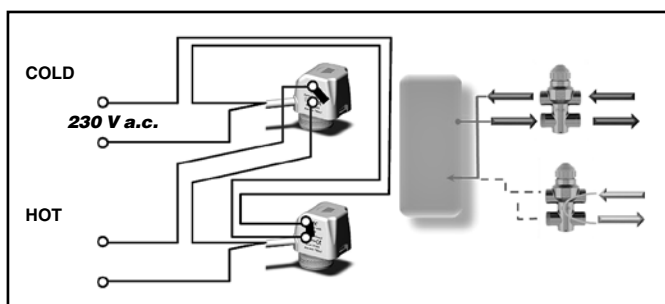

Balancing valves independent from the system pressure

- The balancing valve and a combined 2 way valve allow the regulation of the water flow value autonomously, regardless of the system pressure, and the control of the flow by using an ON/OFF electro-thermal actuator.
- The balancing valve allows you to balance the hydraulic system by supplying the required water flow, for each fan- coil, and to maintain it even under partial load conditions.
- A graduated ring nut placed under the valve allows you to set the flow rate value and also allows direct reading of the set value.



Valve operation logic

- “p1” is the valve inlet pressure.
- “p3” is the outlet pressure.
- “p2” is the diaphragm activation pressure, which allows differential pressure “p2” - “p3” to be maintained at a constant value, in order to guarantee the water to flow at the set value.

The minimum differential pressure “p1” – “p3”, required to guarantee the correct value of the set water flow rate, is indicated in the diagrams on page 48. This is an essential factor to size the system pressure drop and pump pressure head. The flow rate is kept at a constant value only if the valve pressure drop is higher than the indicated value.

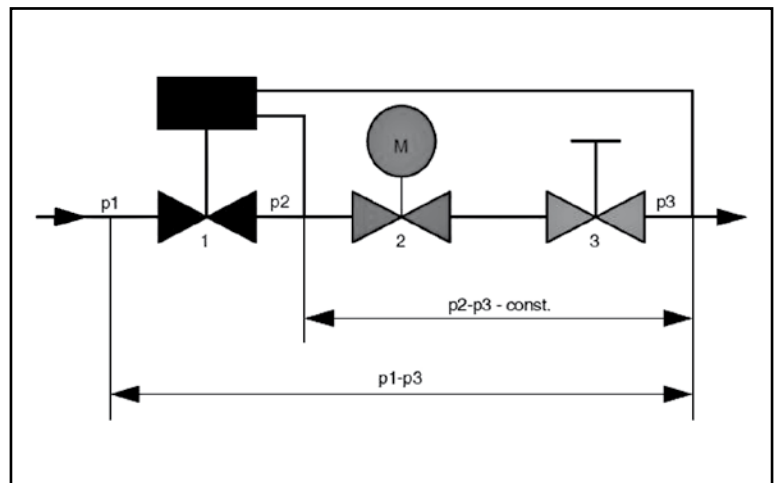

Minimum operating differential pressure

The minimum differential pressure and the balancing valve pressure drop must be considered to size the system pumps. Flow rate is constant if the pressure drop is higher than that indicated in the diagrams on page 48. The following diagram shows an example of the flow rate trend according to the pressure drop and calibration required.

Example DN 10 Model

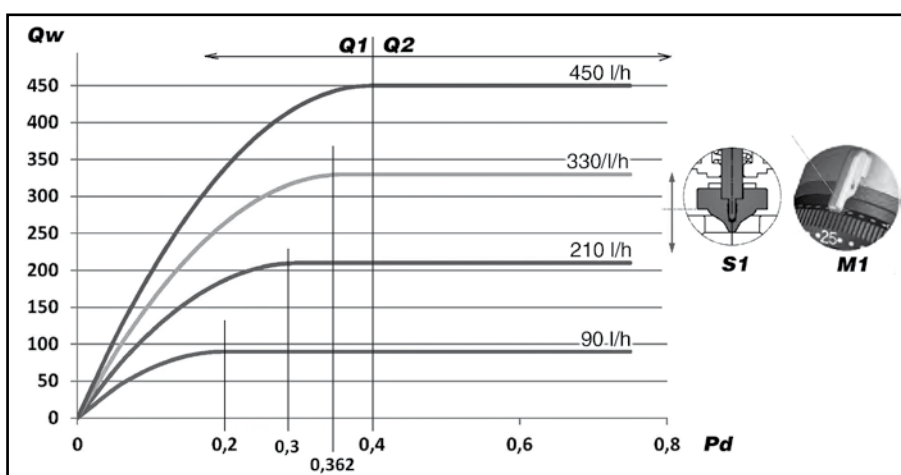

LEGEND:

- Qw** = Water flow rate
- Pd** = Min. differential pressure “p1” – “p3” (bar)
- Q1** = Area with inconstant water flow
- Q2** = Area with constant water flow
- S1** = Position of the adjustment valve plunger
- M1** = Position of the knob

The valve upstream-downstream minimum differential pressure (“p1” – “p3”), which depends on the valve calibration value, must be exceeded to access the constant flow rate field.

DN 10 Model

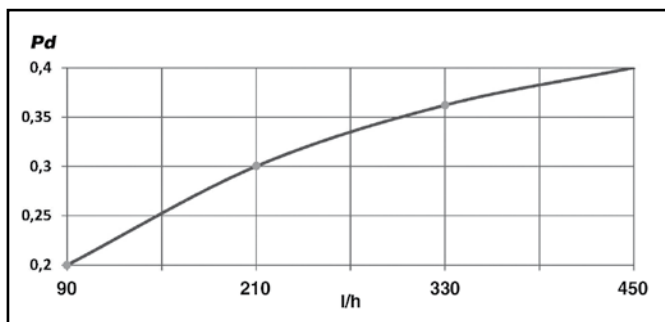

DN 15 Model

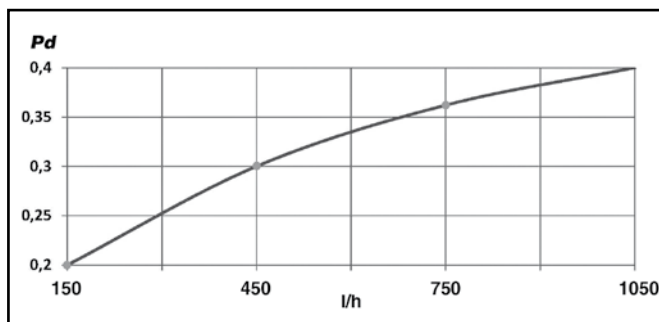

DN 20 Model

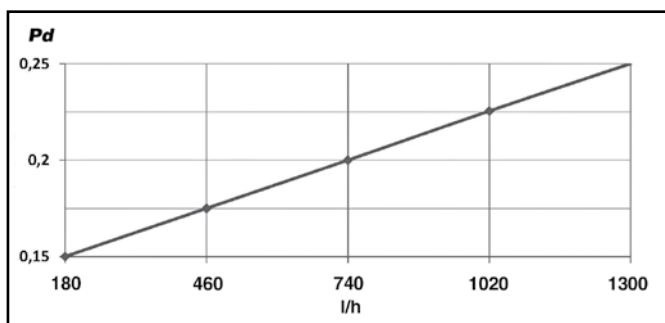

LEGEND:

Pd = Min. differential pressure “p1” – ”p3” (bar)

E.g., when sizing the system pump, in which the **DN 10** valves will be installed and in which 210 l/h are constantly required for each device, consider a useful pressure of 0.3 bar (to compensate the pressure drop of the valve) for each balancing valve. Therefore, the pressure drop values produced by the system balancing valves must be summed and the pump must be sized to produce a pressure equal to or greater than the value obtained previously.

Benefits

- Reduced dimensions.
- Easy installation on 2 or 4 pipe devices.
- Pre-regulation of the nominal value set even with installed actuator.
- Easy display of the nominal value set. Nominal values are indicated in 10 l/h without any conversion.
- Guarantee of constant flow rate set even with partial loads.
- Pre-regulation can be blocked and leaded with the locking ring.

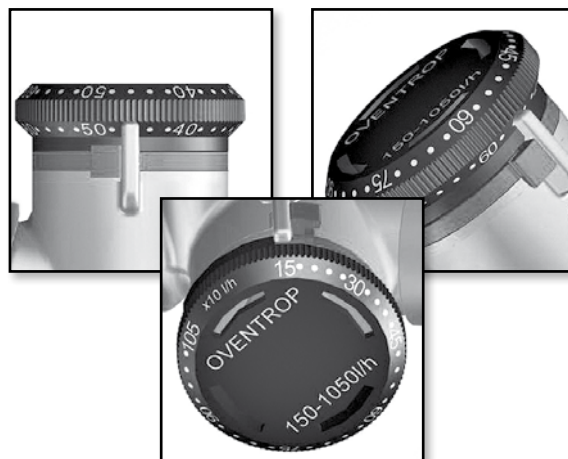

Technical features

DN MOD.	Flow Rate Range (l/h)	Kvs
DN 10	90 – 450	1,1
DN 15	150 – 1050	1,8
DN 20	180 – 1300	2,5

Operation limits of the balancing valves

- Maximum operating temperature 120°C
- Maximum operating pressure 16 bar
- Maximum % of water/glycol mixture 50%
- Minimum operating temperature -10°C
- Maximum differential pressure 4 bar

Balancing valves for main coil

2 way valve for main coil and assembly kit.
The valve is supplied equipped with 230 Volt electro-thermal actuator for the ON/OFF control.

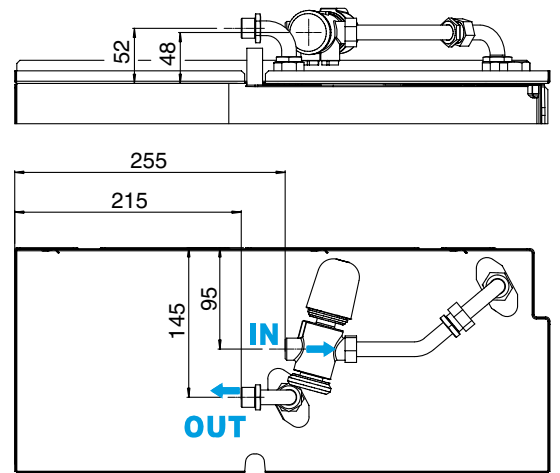

Version	SEC/F-ECM
MODEL	CV - CH - CVB - NC

-ECM MOD.				FITTED		NOT FITTED	
	SEC/F	DN	(Ø)	Range	CODE	TYPE	CODE
1 ÷ 3	10	1/2"	90 – 450	9066660	V2OVBPM 90-450	9066650	V2OVBPS 90-450
4 ÷ 7	15	3/4"	150 – 1050	9066661	V2OVBPM 150-1050	9066651	V2OVBPS 150-1050
8 - 9	20	1"	180 – 1300	9066662	V2OVBPM 180-1300	9066652	V2OVBPS 180-1300

Balancing valves for additional coil

2 way valve for additional coil and assembly kit.
The valve is supplied equipped with 230 Volt electro-thermal actuator for the ON/OFF control.

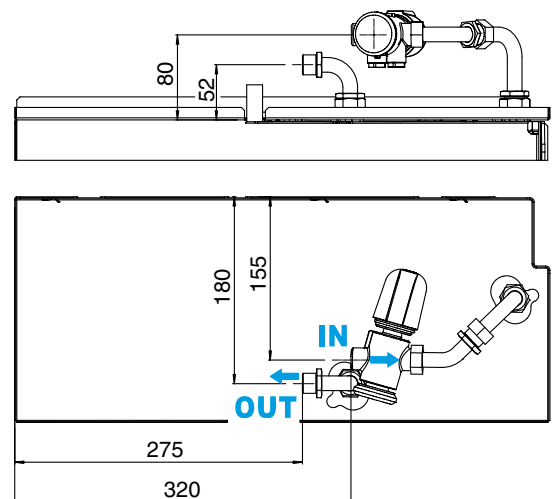

Version	SEC/F-ECM
MODEL	CV - CH - CVB - NC

-ECM MOD.				FITTED		NOT FITTED	
	SEC/F	DN	(Ø)	Range	CODE	TYPE	CODE
1 ÷ 5	10	1/2"	90 – 450	9066663	V2OVBAM 90-450	9066653	V2OVBAS 90-450
6 ÷ 9	15	3/4"	150 – 1050	9066664	V2OVBAM 150-1050	9066654	V2OVBAS 150-1050

2 pipe system

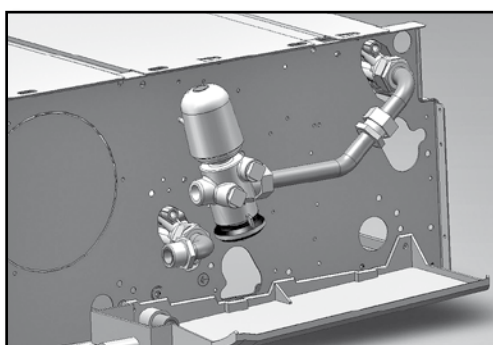

4 pipe system

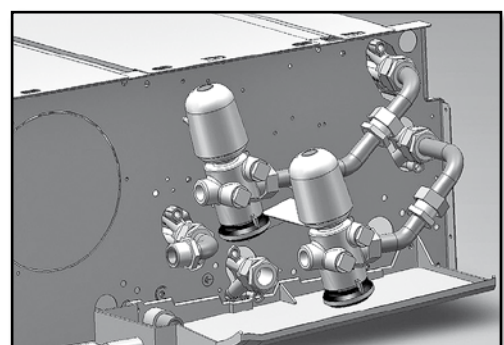

BREEZE frame kit for wall concealed installation

The Breeze frame kit is available in 3 sizes and allows the installation of recessed SEC/F-ECM fan coils. The kit includes a top closing panel that prevents the access to technical spaces and coil ensuring the safety of the end user.



Recessed box kit



Aesthetic frame kit



The **Aesthetic frame kit** and the **Recessed box kit** have different codes as they are separately delivered with their own packaging and they must be assembled together. These items are only suitable for SEC/F-ECM models, NC version, 2-6 sizes. When the Fan Coil is equipped with the Recessed box kit, it must be connected to a remote control and it is not possible to use the built-in electronic controls. With the Breeze frame kit the simplified valve kits can not be installed.

Technical characteristics of the main components:

The aesthetic frame includes:

- the closing frame;
- air supply louvre;
- front panel;
- air intake grid.

Perimeter frame, front panel and intake grid are made of steel painted with epoxy polyester coat, dried in a furnace at 180°, colour RAL 9003. It is possible to repaint the entire frame of the same color as the wall.



The air supply louvre is made of extruded aluminum with satin finish.



The Grid is fixed to the frame by using a simple and fast connecting system and it can be easily removed to clean the filter and the inner casing.



The recessed box is made of galvanized steel with opening for the electrical and hydraulic connections. To fit in the Fan Coil easily, there are 4 grub screws.



Aesthetic frame dimensions

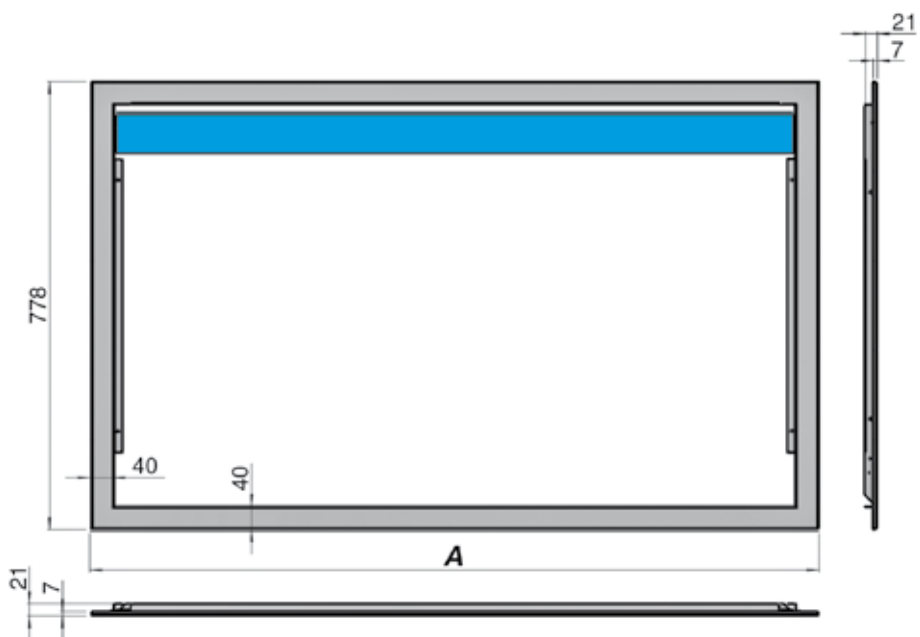

Version	SEC/F-ECM
MODEL	NC

SIZE	TYPE	A	CODE
2	CBR-A	837	9076452
3 - 4	CBR-B	1052	9076453
5 - 6	CBR-C	1267	9076455

Packaged Aesthetic Frame Weight
10,5
12,5
14,5

PACKAGED AESTHETIC FRAME WEIGHT



Recessed box dimensions

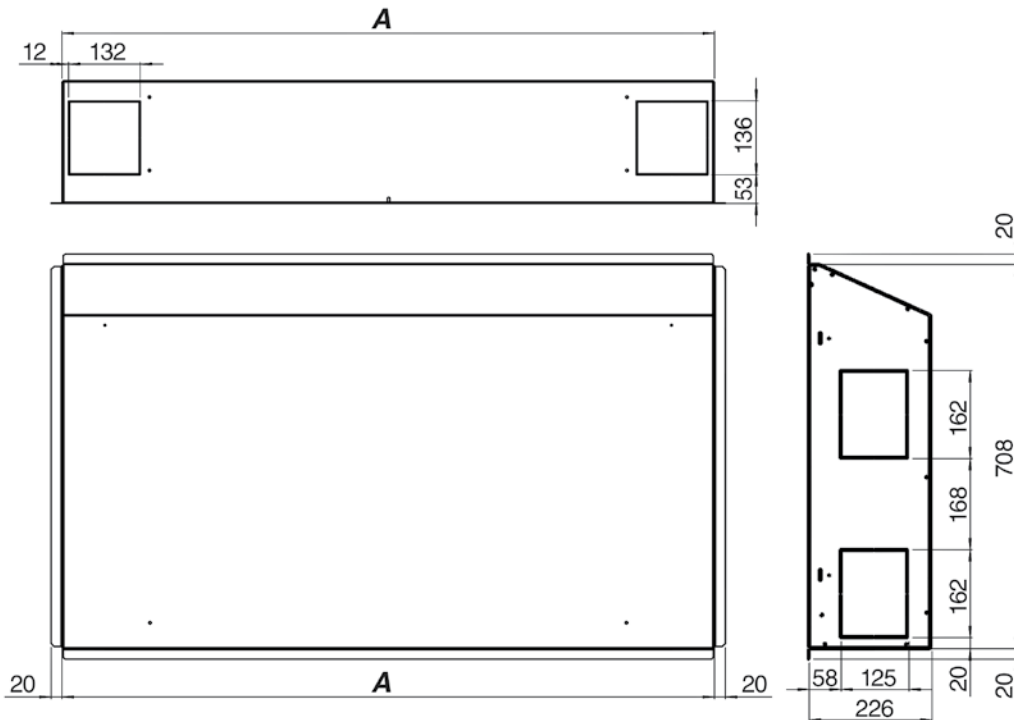

Version	SEC/F-ECM
MODEL	NC

SIZE	TYPE	A	CODE
2	IBR 2	771	9076462
3 - 4	IBR 3-4	986	9076463
5 - 6	IBR 5-6	1201	9076465

Packaged Aesthetic Frame Weight
13
16
18



BEL electric heater

1 PHASE 230V

Electric heater with integral: safety thermostat and relay control.

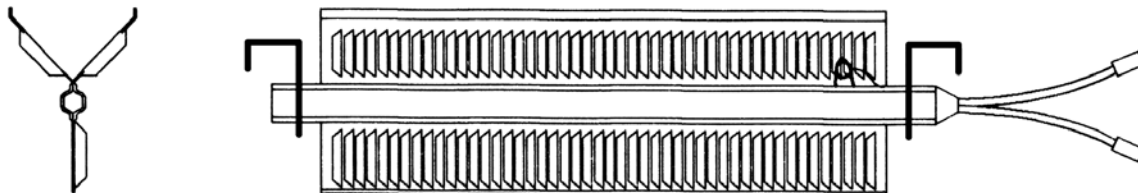

Version	SEC/F-ECM
MODEL	CV - CH - CVB - NC

Version	SEC/F-ECM
MODEL	NC

SIZE		
SEC/F-ECM	WATT	CODE
1	650	9066491E
	1000	9066492E
2	600	9066482E
	400	9066472E
4	1500	9066493E
	900	9066483E
	600	9066473E
6	2000	9066495E
	1250	9066485E
	750	9066475E
7 - 9	2500	9066497E
	1500	9066487E
	1000	9066477E

SIZE		
SEC/F-ECM	WATT	CODE
1	650	9066611
	1000	9066612
2	600	9066602
	400	9066592
4	1500	9066613
	900	9066603
	600	9066593
6	2000	9066615
	1250	9066605
	750	9066595
7 - 9	2500	9066617
	1500	9066607
	1000	9066597

NOTE: the electric heater must be fitted on the fan coil unit on site and can not be added later.

BSV-C extension condensate collection tray to cover valve assembly

(for vertical units)

Version	SEC/F-ECM
MODEL	CV - CVB - NC (vertical)
CODE	6060400

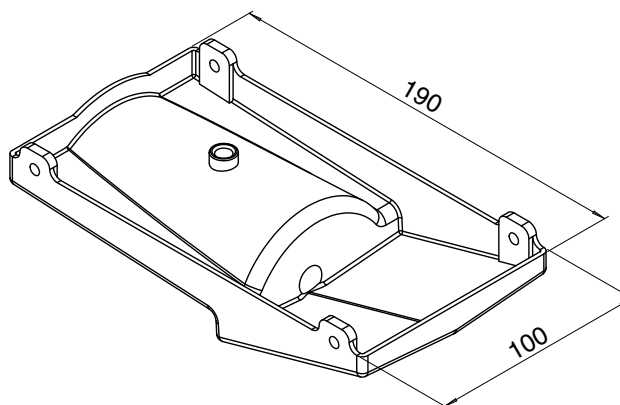

BSO-C extension condensate collection tray to cover valve assembly
(for horizontal units)

Version	SEC/F-ECM	
MODEL	CH - NC (horizontal)	
Connection side	LEFT	RIGHT
TYPE	BSO-C-SX	BSO-C-DX
CODE	6060402	6060403

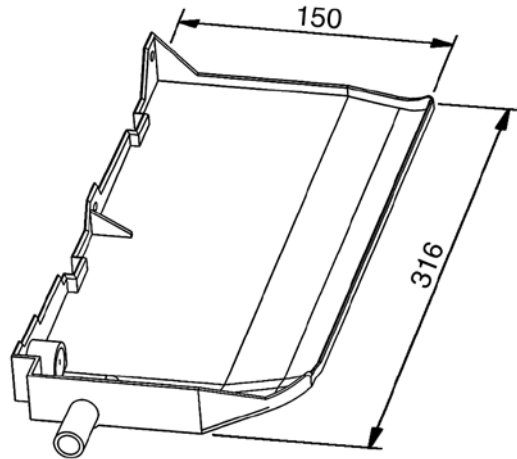

BSI-C extension condensate collection tray to cover valve assembly
(for horizontal units)

Version	SEC/F-ECM
MODEL	NC (horizontal)
CODE	6066039

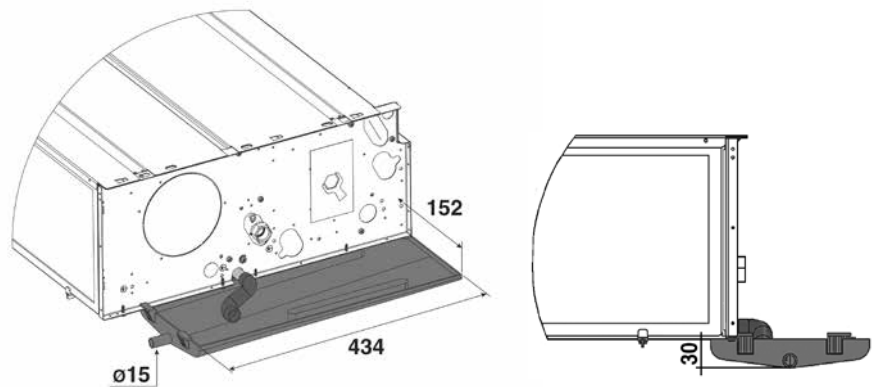

Not to be used with **KAF**.

DRPV-C fitted condensate pump
(for vertical units)

Version	SEC/F-ECM
MODEL	CV - CVB - NC (vertical)

	FITTED	NOT FITTED
TYPE	DRPV-C-M	DRPV-C-S
CODE	9066297	9066296



Height for vertical flow (m)	Water flow (l/h) depending on the length of horizontal flow	
	5 m	10 m
1	7,6	7,2
2	5,6	5,2
3	4,0	3,7
4	3,2	2,9

DRPO-C fitted condensate pump
(for horizontal units)

Version	SEC/F-ECM
MODEL	CV (horizontal)

	FITTED	NOT FITTED
TYPE	DRPO-C-M	DRPO-C-S
CODE	9066295	9066294

Height for vertical flow (m)	Water flow (l/h) depending on the length of horizontal flow	
	5 m	10 m
1	7,6	7,2
2	5,6	5,2
3	4,0	3,7
4	3,2	2,9

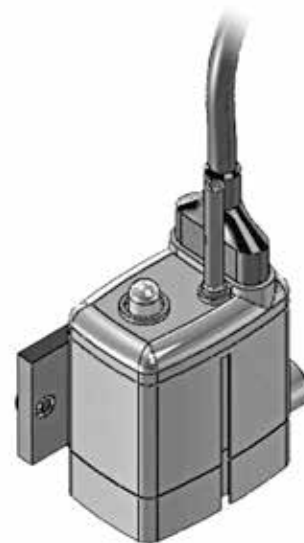

DRPI-C condensate pump
(for horizontal units)

Version	SEC/F-ECM
MODEL	NC (horizontal)

	FITTED	NOT FITTED
TYPE	DRPI-C-M	DRPI-C-S
CODE	9066298	9066180

Height for vertical flow (m)	Water flow (l/h) depending on the length of horizontal flow	
	5 m	10 m
1	7,6	7,2
2	5,6	5,2
3	4,0	3,7
4	3,2	2,9



SCR plastic condensate drain pipe with fast connection
(allows correct condensate drain)

Version	SEC/F-ECM
MODEL	CH - NC
CODE	6060420

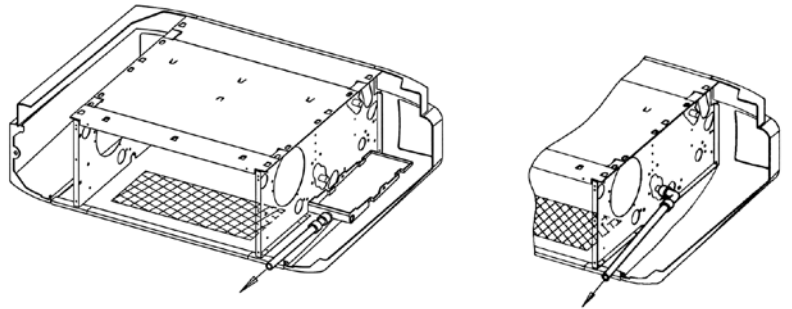

PAP feet

Version	SEC/F-ECM
MODEL	CV

SIZE	L	CODE
2	430	9060150
4	645	9060150
6	860	9060150
7	1119	9060150
9	1119	9060151

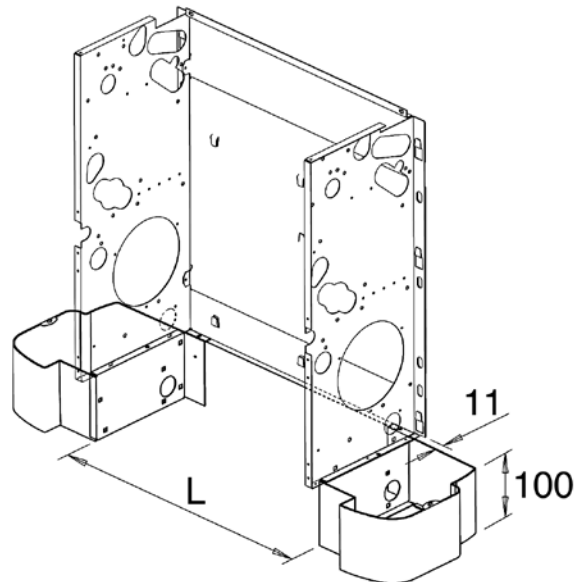

GAP

Aluminium low intake grid (to be installed with PAP feet)

Version	SEC/F-ECM
MODEL	CV

SIZE	CODE
2	9066542
4	9066543
6	9066545
7 - 9	9066547

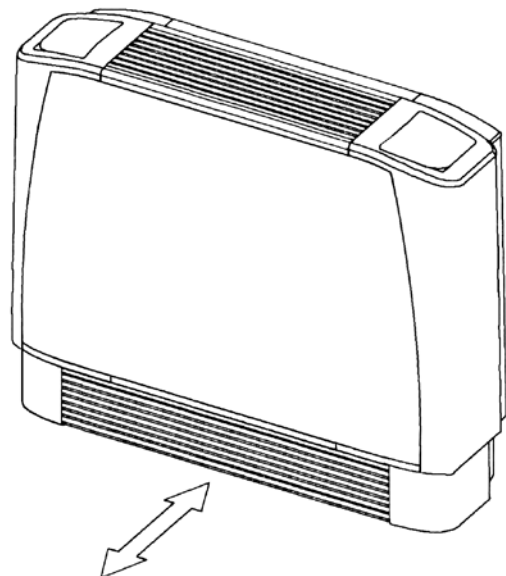

KAF frontal intake kit

Bottom closing panel and filter sliding guides.

Version	SEC/F-ECM
MODEL	NC

SIZE	CODE
2	9066502
4	9066503
6	9066505
7	9066507
9	9066508

Not to be used with BSI-C.

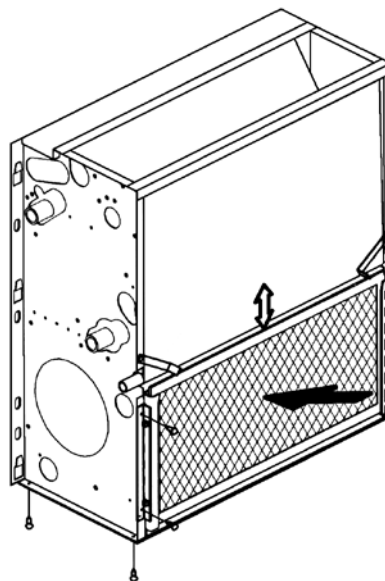

PCVF rear closing panel

(for vertical units)

Version	SEC/F-ECM
MODEL	CV - CVB

SIZE	CODE
2	9060180
4	9060181
6	9060182
7 - 9	9060183
9	9066508

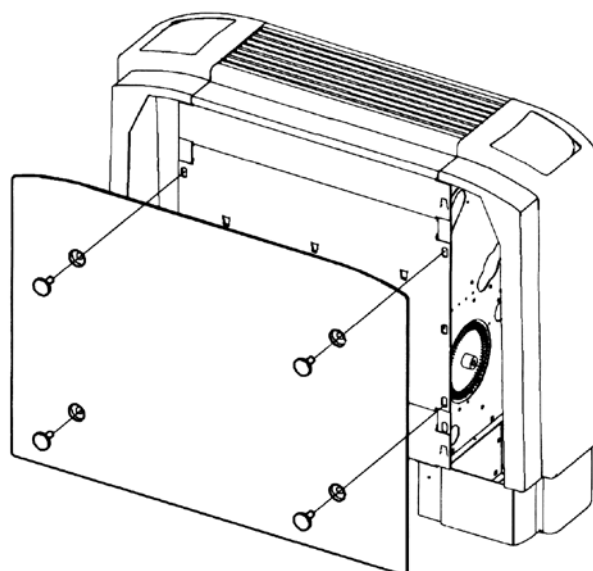

PCOF bottom closing panel

(for horizontal units)

Version	SEC/F-ECM
MODEL	CH

SIZE	CODE
2	9060190
4	9060191
6	9060192
7	9060193
9	9060194

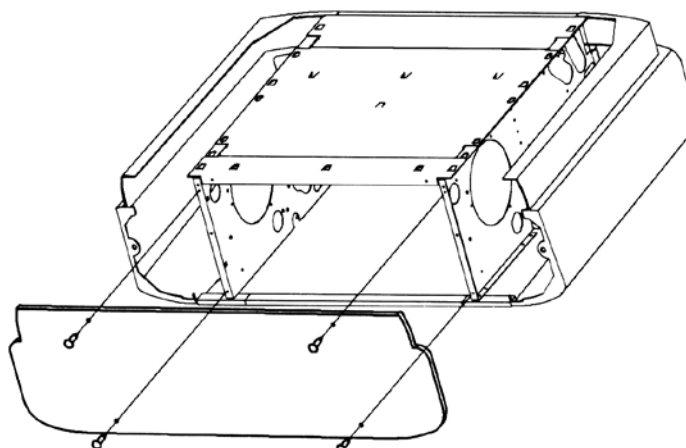

SAEM fresh air mixing damper

(factory mounted with feet and intake grid included, MV only)

(can not be motorized)

Version	SEC/F-ECM
MODEL	CV

SIZE	A	B	L	CODE
2	186	78	454	9076332
4	186	78	669	9076333
6	186	78	884	9076335
7	186	78	1099	9076337
9	216	108	1099	9076338

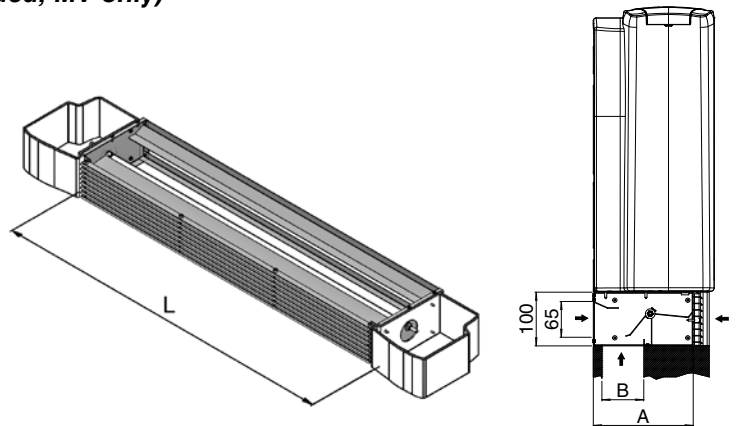

SAE fresh air mixing damper

(not mounted, IV - IO only)

(can not be motorized)

Version	SEC/F-ECM
MODEL	NC

SIZE	A	B	L	CODE
2	186	78	454	9066532
4	186	78	669	9066533
6	186	78	884	9066535
7	186	78	1099	9066537
9	216	108	1099	9066538

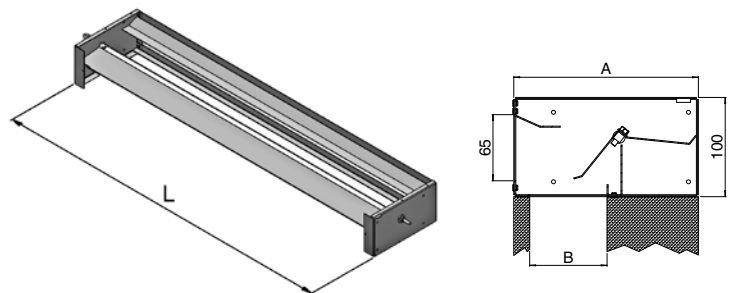

FRD straight inlet flange

Can be used together with GRAG air inlet grid.
Made of galvanized steel.

Version	SEC/F-ECM
MODEL	NC

SIZE	TYPE	A	B	C	D	G	CODE
2	FRD - 2	454	390	32	216	16	9060720
4	FRD - 3/4	669	590	39,5	216	16	9060721
6	FRD - 5/6	884	790	47	216	16	9060722
-	FRD - 4S	884	790	47	246	46	9038002
7	FRD - 7	1099	990	54,5	216	16	9060723
9	FRD - 8/9	1099	990	54,5	246	46	9060724

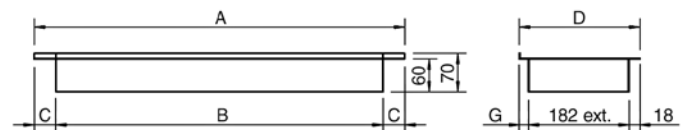

FR 90 90° inlet flange

Can be used together with GRAP air inlet grid.
Made of galvanized steel.

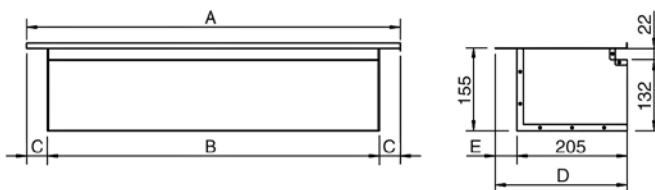

Version	SEC/F-ECM
MODEL	NC

SIZE	TYPE	A	B	C	D	E	CODE
2	FR90 - 2	454	390	32	216	11	9060710
4	FR90 - 3/4	669	590	39,5	216	11	9060711
6	FR90 - 5/6	884	790	47	216	11	9060712
-	FR90 - 4S	884	790	47	246	41	9038001
7	FR90 - 7	1099	990	54,5	216	11	9060713
9	FR90 - 8/9	1099	990	54,5	246	41	9060714

GRAP air inlet grid

To be used with FR 90 90° inlet flange.
Made of anodized aluminium.

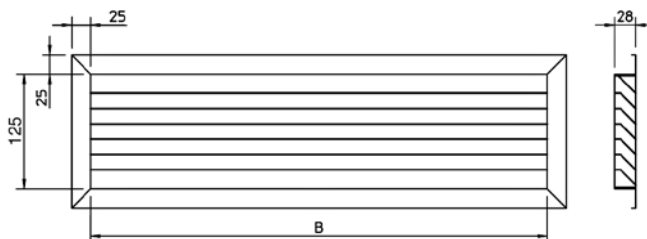

Version	SEC/F-ECM
MODEL	NC

SIZE	TYPE	Description	B	CODE
2	GRAP - 2	Grid 400x150	375	9060760
4	GRAP - 3/4	Grid 600x150	575	9060761
6	GRAP - 5/6	Grid 800x150	775	9060762
7 - 9	GRAP - 7/9	Grid 1000x150	975	9060763

GRAG air inlet grid

To be used with FRD straight inlet flange.
Made of anodized aluminium.

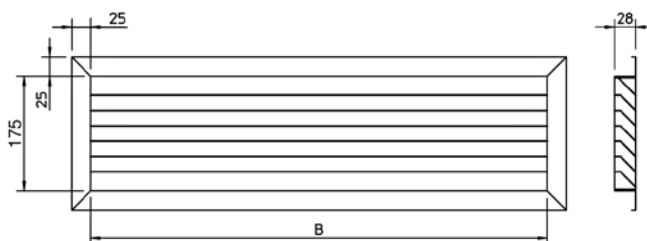

Version	SEC/F-ECM
MODEL	NC

SIZE	TYPE	Description	B	CODE
2	GRAG - 2	Grid 400x200	375	9060764
4	GRAG - 3/4	Grid 600x200	575	9060765
6	GRAG - 5/6	Grid 800x200	775	9060766
7 - 9	GRAG - 7/9	Grid 1000x200	975	9060767

FRC fresh air connection
(not mounted)

Version	SEC/F-ECM
MODEL	NC

SIZE	TYPE	A	CODE
2 ÷ 9	FRC - 100	98	6064191
2 ÷ 9	FRC - 120	122	6064192

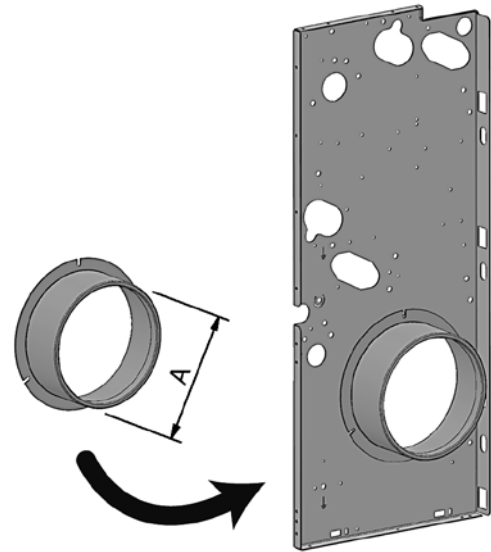

FMD straight outlet flange

Made of galvanized steel.

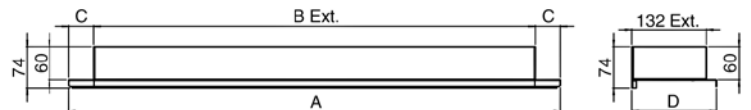

Version	SEC/F-ECM
MODEL	NC

SIZE	TYPE	A	B	C	D	CODE
2	FMD - 2	452	390	31	152	9066372
4	FMD - 3/4	667	590	38,5	152	9066373
6	FMD - 5/6	882	790	46	152	9066375
-	FMD - 4S	882	790	46	179	9069232
7	FMD - 7	1097	990	53,5	152	9066377
9	FMD - 8/9	1097	990	53,5	179	9066378

FM 90 90° outlet flange

Made of galvanized steel
insulated with polyethylene lining.

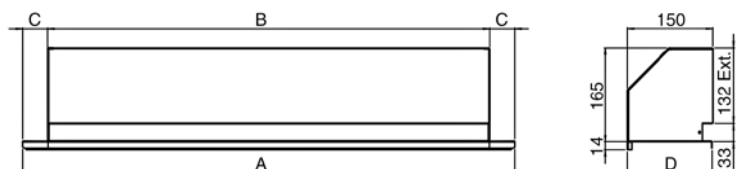

Version	SEC/F-ECM
MODEL	NC

SIZE	TYPE	A	B	C	D	CODE
2	FM90 - 2	452	390	31	152	9066382
4	FM90 - 3/4	667	590	38,5	152	9066383
6	FM90 - 5/6	882	790	46	152	9066385
-	FM90 - 4S	882	790	46	179	9060242
7	FM90 - 7	1097	990	53,5	152	9066387
9	FM90 - 8/9	1097	990	53,5	179	9066388

BMA air outlet grid

Double louvre grid to be fitted to the duct, to the FMD straight outlet flange or to the FM 90° 90° outlet flange.

Made of anodized aluminium.

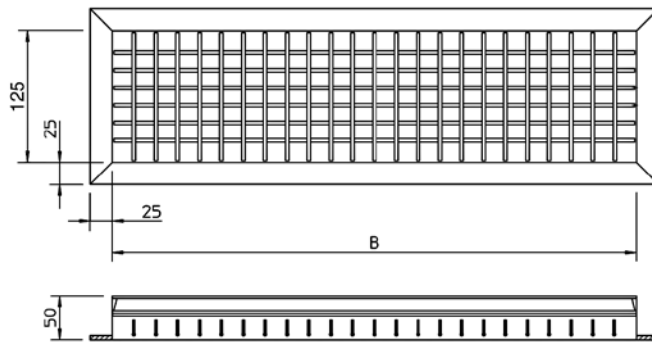

Version	SEC/F-ECM
MODEL	NC

SIZE	TYPE	B	CODE
2	BMA - 2	375	9060750
4	BMA - 3/4	575	9060751
6	BMA - 5/6	775	9060752
7 - 9	BMA - 7/9	975	9060753

PRC air inlet spigot plenum

Made of galvanized steel insulated with polyethylene lining.

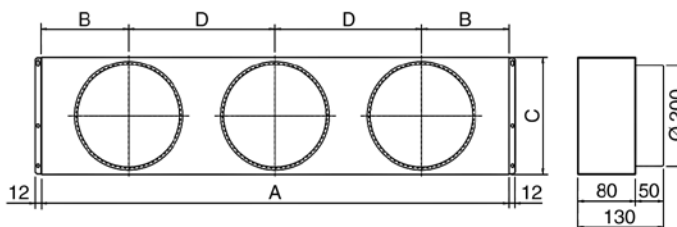

All the plenums are supplied with spigots for the connection of flexible ducts.

Version	SEC/F-ECM
MODEL	NC

SIZE	TYPE	A	B	C	D	Spigots	CODE
2	PRC - 2	430	107	218	216	N° 2	9066462
4	PRC - 3/4	645	166	218	313	N° 2	9066463
6	PRC - 5/6	860	160	218	270	N° 3	9066465
-	PRC - 4S	860	160	248	270	N° 3	9038050
7	PRC - 7	1075	190	218	347,5	N° 3	9066467
9	PRC - 8/9	1075	190	248	347,5	N° 3	9066468

PMC spigot diffuser

Made of galvanized steel insulated with polyethylene lining.

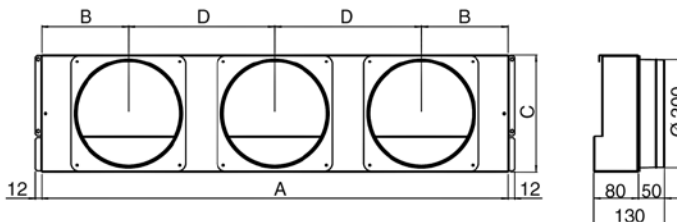

All the plenums are supplied with spigots for the connection of flexible ducts.

Version	SEC/F-ECM
MODEL	NC

SIZE	TYPE	A	B	C	D	Spigots	CODE
2	PMC - 2	430	107	218	216	N° 2	9066362
4	PMC - 3/4	645	166	218	313	N° 2	9066363
6	PMC - 5/6	860	160	218	270	N° 3	9066365
-	PMC - 4S	860	160	248	270	N° 3	9069222
7	PMC - 7	1075	190	218	347,5	N° 3	9066367
9	PMC - 8/9	1075	190	248	347,5	N° 3	9066368

GRAFP air inlet grid with filter

To be fitted to the FR 90 90° inlet flange.
Made of anodized aluminium.

Version	SEC/F-ECM
MODEL	NC

SIZE	TYPE	B	CODE
2	GRAFP - 2	375	9060770
4	GRAFP - 3/4	575	9060771
6	GRAFP - 5/6	775	9060772
7 - 9	GRAFP - 7/9	975	9060773

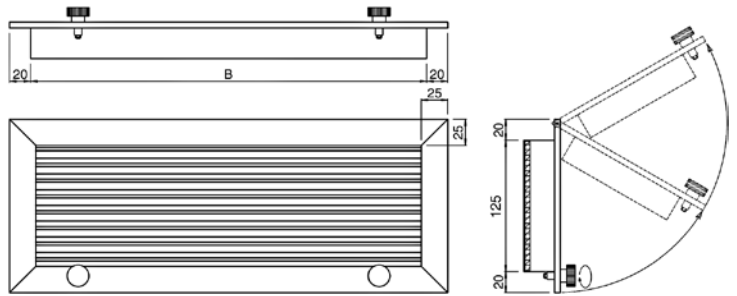

GRAFG air inlet grid with filter

To be fitted to the FRD straight inlet flange.
Made of anodized aluminium.

Version	SEC/F-ECM
MODEL	NC

SIZE	TYPE	B	CODE
2	GRAFG - 2	375	9060774
4	GRAFG - 3/4	575	9060775
6	GRAFG - 5/6	775	9060776
7 - 9	GRAFG - 7/9	975	9060777

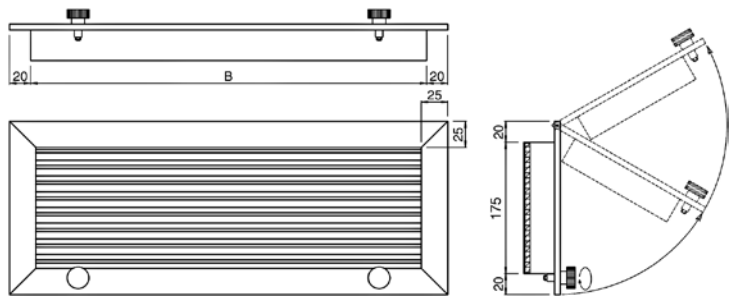

CHK Hotel fan kit

Hotel box for concealed installation for Carisma SEC/F-ECM, NC model (frontal return and supply).

The new CHK kit is the best solution for all installations requiring a built-in fan coil where there is no other possibility of accessing the unit except from the air outlet side. The unit is particularly suitable for installation in hotel rooms, offices and homes.

The Kit consists of a box that can easily be installed in a false ceiling, inside which the fan coil is fitted using the special guides. For simply remove the front outlet and access the air filter as well as the electrical and hydraulic parts of the unit.

The air grid is divided into two zones, one for the air intake with horizontally adjustable fins and the other one for the air outlet with horizontally and vertically adjustable fins to ensure better air distribution and diffusion in the room.

The box structure is made of thick galvanised metal sheet.

The internal air flow sections are insulated with expanded polyethylene that prevents both condensation and energy loss towards the inside of the false ceiling.

The accessory includes the air filter, an anodised aluminium outlet with adjustable fins and a front wall frame.

The box structure is designed so that fan coils with hydraulic connections facing left or right can be installed. According to the configuration, it is in fact sufficient to secure the sliding guides on the panel that will be the upper one.

When ordering, it must be specified that the fan coil hydraulic and electrical connections must be on the same side.



Note: consider 20 Pa pressure drop.

Version	SEC/F-ECM
MODEL	NC

SIZE	TYPE	A	CODE
3 - 4	CHK 3-4	1060	9066783
5 - 6	CHK 5-6	1316	9066785
7	CHK 7	1610	9066787

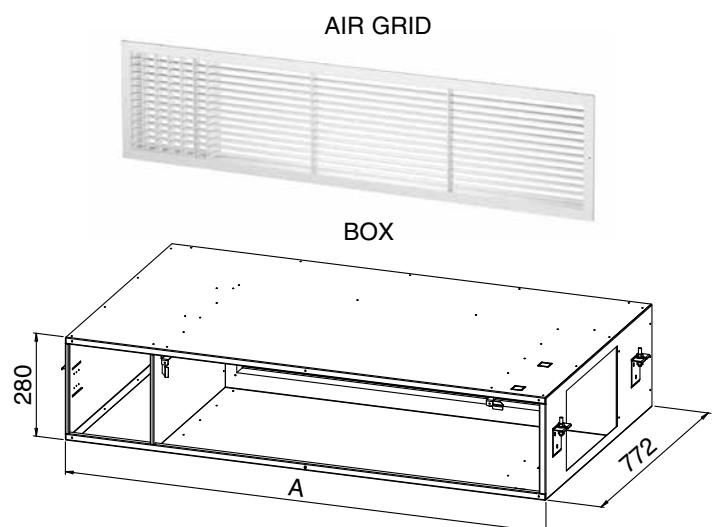

BXS silencers plenum

Sound attenuator module.

Made of galvanised steel metal sheet, lined internally with a reinforced glass wool mat on both sides with a black glass coating; the 50 mm and 30 kg/m³ density lining ensures high noise reduction with very low pressure drops.

Sound attenuation levels

FREQUENCY	Hz	125	250	500	1000	2000	4000	8000
SOUND ATTENUATION	dB	2.5	5.0	11.5	14.0	13.5	12.0	11.0

Note: the silencer plenum reduces the sound levels only on the supply side; the sound levels on the return side are not affected by the silencer.

Version	SEC/F-ECM
MODEL	NC

SIZE	TYPE	L	L1	A	CODE
3 - 4	BXS-A	675	597	653	9069081
5 - 6	BXS-B	890	812	868	9069082
7 - 9	BXS-C	1105	1027	1083	9069083

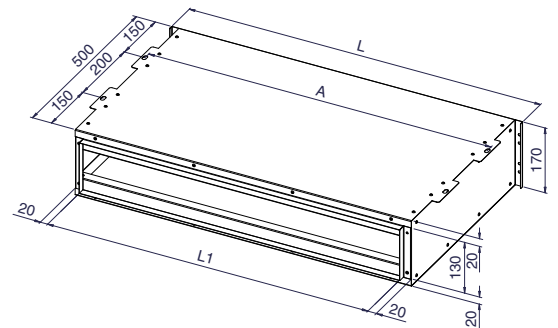

Silencer plenum pressure drop

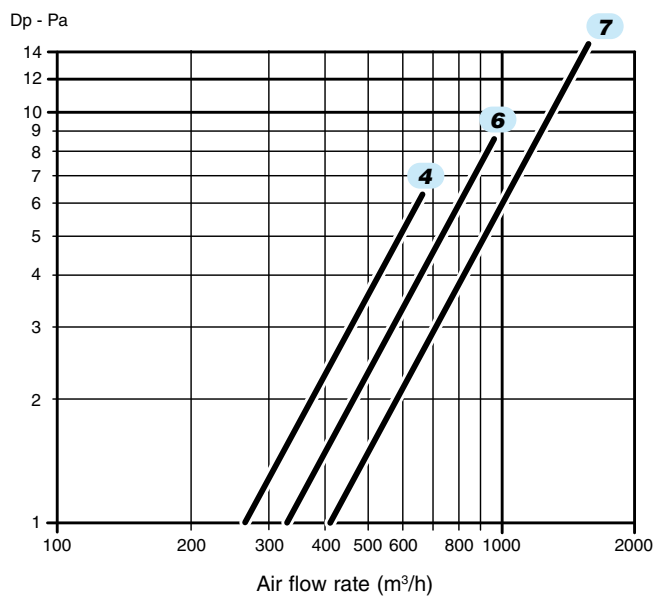

SEC/F-ECM configuration

For this fan coil configuration, the 1-10 Vdc signal, which controls the inverter, must be supplied by a controller with the following signal specifications:

Fan coil control signal

- 0 Vdc = Fan OFF
- >1 Vdc = Fan ON
- 10 Vdc = Maximum speed

ECM Blac board

0÷10 Vdc Circuit Input Impedance Value= 68kOhm

SEC/F-ECM electric wiring diagram

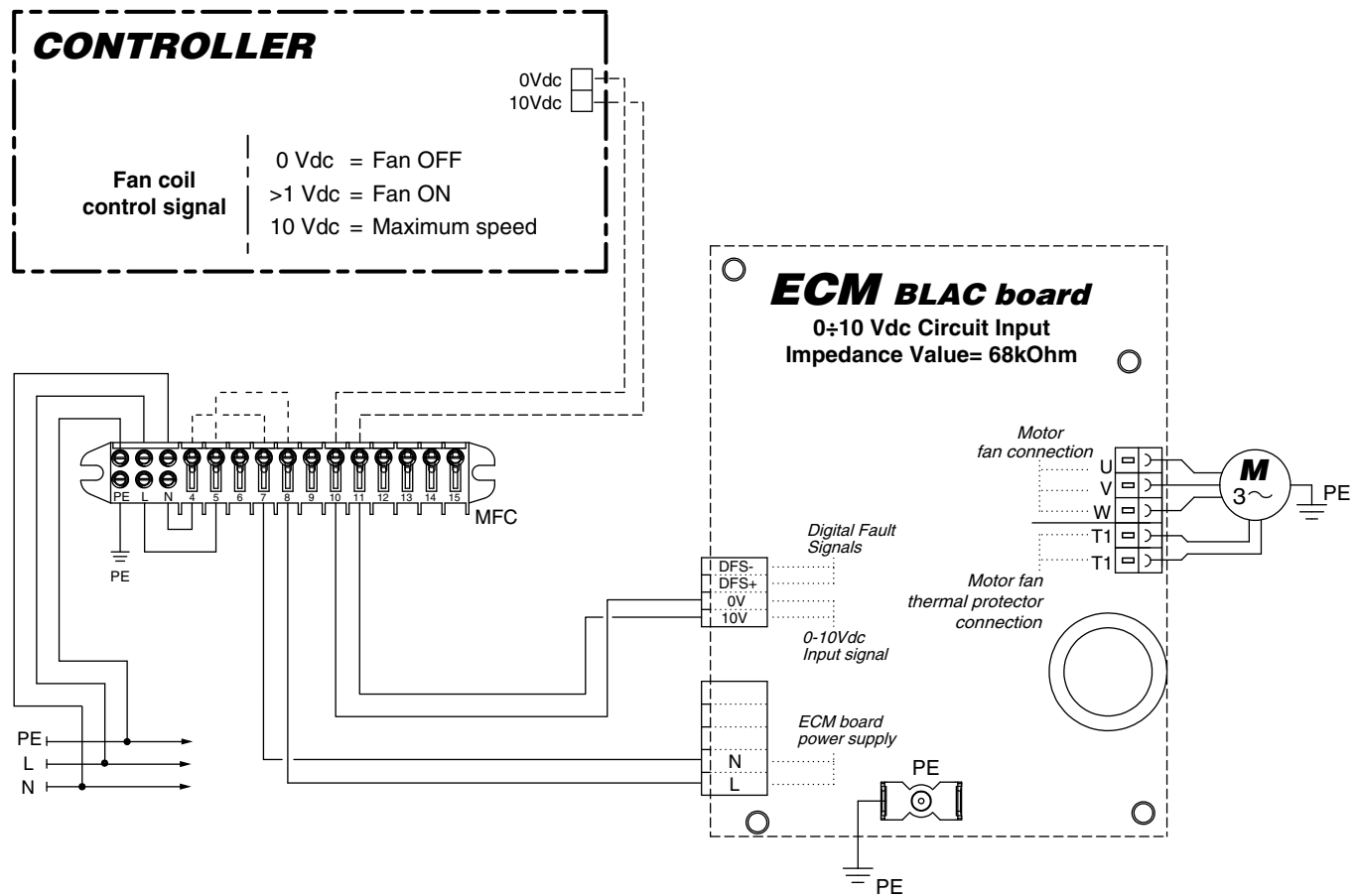

LEGEND:

BLAC = Inverter circuit board **M** = Electronic motor **CONTROLLER** = Controller

Electronic controls to be fitted – SEC/F-ECM version

IDENTIFICATION	CODE
TMV-T-ECM	9060141

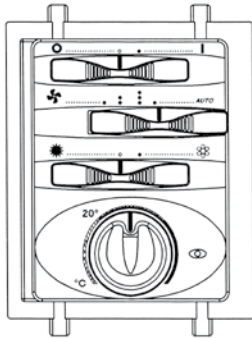

- ON-OFF switch.
- Manual 3 speed switch or automatic continuous speed control.
- Manual Summer/Winter switch.
- Continuous speed control based on the difference between ambient temperature and Set temperature (speed switch in Auto position).
- Electronic room thermostat for fan or valve control (ON-OFF).
- Simultaneous thermostatic control of the valves and fan.
- It allows to control low temperature cut-out (NTC).

Control power absorption: 1,5 VA

DESCRIPTION	IDENTIFICATION	CODE
T-MB remote control (fitted on the unit) for CV/CVB models (UP-AU included)	T-MB-M-UP	9066675
T-MB remote control (not fitted on the unit) for CV/CVB models (UP-AU included)	T-MB-S-UP	9066674

The control must always be connected with UP-AU power unit (fitted on the unit) or with UP-AU power unit (not fitted on the unit).

Wall control with display that allows controlling one or more units in Master/Slave mode. The control is equipped with internal sensor to detect the room temperature, which can be defined as a priority compared to the return air sensor on the fan coil.



Dimensions: 110x72x25 mm

The T-MB control features the following functions:

- Switch the unit ON and OFF.
- Temperature set.
- Manual, centralized or automatic Summer/Winter switch.
- Set the fan speed (low, medium, high or autofan).
- Set the operation mode (fan only, cooling, heating; auto for 4 pipe systems with mode selection depending on the air temperature).
- Possibility of use of the low temperature cut-out thermostat NTC mounted on the UP-AU power unit.
- It allows to control the water valves (ON-OFF) and the electric heater managed as main heating element or as an integration element.
- Time setting.
- Weekly ON/OFF program.

Control power absorption: see the UP-AU power unit

Wall electronic controls – SEC/F-ECM version

IDENTIFICATION	CODE
WM-AU	9066632E



Dimensions: 135x86x24 mm

The control must always be connected with UP-AU power unit (fitted on the unit) or with UP-AU power unit (not fitted on the unit).

- ON-OFF switch.
- Manual, automatic or centralized Summer/Winter switch.
- Manual or automatic 3 speed progressive switch.
- Summer/Winter/Fan/Auto mode switch.
- Electric heater / IAQ filter activation switch.
- Electronic room thermostat for fan control (ON-OFF).
- Electronic room thermostat for valve control (ON-OFF).
- Simultaneous thermostatic control of the valves and fan.
- It allows to control the low temperature cut-out thermostat (NTC) mounted on the UP-AU power unit.
- It allows to control the water valves (ON-OFF) and the electric heater managed as main heating element or as an integration element.
- Energy saving switch.
- Presence of a LED signal when the thermostat is on.

N.B.: with 4 pipe installations and continuous chilled and hot water supply, it allows the automatic summer winter change-over in accordance to the room temperature (-1°C = Winter, +1°C = Summer, Neutral Zone 2°C).

Control power absorption: see the UP-AU power unit

IDENTIFICATION	CODE
T-MB	9066631E



Dimensions: 110x72x25 mm

The control must always be connected with UP-AU power unit (fitted on the unit) or with UP-AU power unit (not fitted on the unit).

Wall control with display that allows controlling one or more units in Master/Slave mode. The control is equipped with internal sensor to detect the room temperature, which can be defined as a priority compared to the return air sensor on the fan coil.

The T-MB control features the following functions:

- Switch the unit ON and OFF.
- Temperature set.
- Manual, centralized or automatic Summer/Winter switch.
- Set the fan speed (low, medium, high or autofan).
- Set the operation mode (fan only, cooling, heating; auto for 4 pipe systems with mode selection depending on the air temperature).
- Possibility of use of the low temperature cut-out thermostat NTC mounted on the UP-AU power unit.
- It allows to control the water valves (ON-OFF) and the electric heater managed as main heating element or as an integration element.
- Time setting.
- Weekly ON/OFF program.

Control power absorption: see the UP-AU power unit

IDENTIFICATION	CODE
WM-503-AC-EC	9066686E



Dimensions: 68x52.2x(wall protrusion=12) mm

The WM-503-AC-EC control for fan coils with valves, is designed to be installed in a 503 wall box. Easy to use, it is equipped with a large and efficient backlit LCD screen with 4 keys. The thermostat is supplied with mounting plate support and the possibility of different combinations with adaptors and covers that make it be used with 28 mounting plates of various brands.

- Manual or automatic 3 speed motor control for asynchronous versions
- EC motor control with 0-10V signal for the ECM versions
- Power supply by UP-503-AC-EC by means of the two-core cable
- Input for return air/water/change over probe
- ON/OFF / SET Reduction / remote SUMMER-WINTER digital input
- User interface with LCD display with adjustable backlight and 4 keys
- Fan coil unit control with 2 and 4 pipes
- Button lock controller
- Parameterization of the system with possibility of customizing the installation, the set point operating limits in summer and winter included.

Control power absorption: see the UP-503-AC-EC power unit

Wall electronic controls – SEC/F-ECM version

DESCRIPTION	IDENTIFICATION	CODE
Power unit for WM-AU and T-MB remote control (fitted on the unit)	UPM-AU	9066641
Power unit for WM-AU and T-MB remote control (not fitted on the unit)	UP-AU	9066640



Power unit to be installed on the fan coil (fan coil interface).

- It controls the fan and the valves of the fan coil.
- It is connected to the electric supply.
- It receives the information required from the control.
- Possibility to use the low temperature cut-out thermostat (optional) for the T1 function which allows the return air control.
- Possibility to use the low temperature cut-out thermostat (optional) for the T2 function which controls the summer/winter switch.
- Possibility to use the low temperature cut-out thermostat (optional) for the T3 function as low temperature cut-out thermostat.
- It allows to control up to 10 units (1 master and 9 slaves).
- Max. Network length: 100 meters.
- Max cable length between control and first connected power unit: 20 meters.

Control power absorption: 2,3 VA

DESCRIPTION	IDENTIFICATION	CODE
Power unit for WM-503-AC-EC	UP-503-AC-EC	9066687



Power unit to be installed on the fan coil (fan coil interface).

- It controls the fan and the valves of the fan coil.
- It is connected to the electric supply.
- It receives the information required from the WM-503-AC-EC remote control.
- It allows to control up to 5 units (1 master and 4 slaves).
- Max. Network length: 100 meters.
- Max cable length between control and first connected power unit: 20 meters.

Power unit absorption: 2 VA

IDENTIFICATION	CODE
WM-S-ECM	9066644



Dimensions: 132x87x23,6 mm

0-10V control with display designed to be mounted on the wall or to be installed on a 503 wall box.

- ON-OFF switch.
- Manual 3 speed switch or automatic continuous speed control.
- Manual Summer/Winter switch.
- Summer/Winter/Fan/Auto mode switch.
- Electronic room thermostat for fan control (ON-OFF).
- Electronic room thermostat for valve control (ON-OFF).
- Simultaneous thermostatic control of the valves and fan.
- It allows to control the low temperature cut-out thermostat (NTC).

Control power absorption: 1,2 VA

Electronic control accessories

NTC low temperature cut-out thermostat

To be fitted between the coil fins; when connecting the control, the NTC probe cable must be separated from the power supply wires.

To be used with the **TMV-T-ECM**, **WM-S-ECM**, **WM-503-AC-EC** controls and the **UP-AU** power unit.

It stops the fan when the water temperature is lower than 28°C and it starts the fan when is higher than 33°C.

To use as:

- T1 function for the return air control.
- T2 function which controls the summer/winter switch.
- T3 function as low temperature cut-out thermostat.

Version	SEC/F-ECM
MODEL	CV - CH - CVB - NC
CODE	3021090



T2 sensor to be placed on the water supply pipe upstream 3 way valves (not to be used with 2 way valve).

The T2 sensor must be used as described below:

- Change-Over for the automatic switch of the operating mode.
If water temperature is lower than 20°C, cooling mode is set; on the other hand, if water temperature exceeds 30°C, heating mode is set.
- It can be used on units with electric heater and hot water supply. The T2 priority probe activates the electric heater or water valve, depending on the water temperature detected. If water temperature exceeds 34°C, the water valve ON-OFF control is activated; on the other hand, if water temperature is lower than 30°C, the electric heater is activated.

To be used with the **UP-AU** power unit.

Version	SEC/F-ECM
MODEL	CV - CH - CVB - NC
CODE	9025310

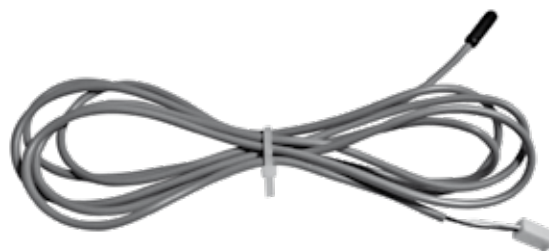

Controls and units **MB** version

All the **SEC/F-ECM** units can be supplied with a wide range of controls, which allows managing one single unit or several units by using the Modbus RTU - RS 485 communication protocol. Units can be managed according to the Master/Slave logic (up to 20 units) or by supervisory components. The system consists in a **MB** board and a series of controls, such as the **T-MB** control, the **RT03** infra-red remote control, the **PSM-DI** multi-function control and the **NET** supervisory program.

MB electronic board

DESCRIPTION	IDENTIFICATION	CODE
<i>MB electronic board fitted on the unit</i>	<i>MB-ECM-M</i>	<i>9066334</i>
<i>MB electronic board supplied with separate packaging</i>	<i>MB-ECM-S</i>	<i>9066335</i>

The **MB** electronic board, to be mounted on the fan coil internal unit, is set to carry out different functions and adjustment modes, in order to meet the installation requirements. These modes are selected by setting the configuration dip switches on the board.

- 2/4 pipe system.
- Electronic room thermostat or automatic fan speed modulation for fan control (ON-OFF).
- Valve ON/OFF thermostatic control and continuous ventilation.
- Valve and simultaneous ventilation ON/OFF thermostatic control.
- Fan operation control depending on the coil temperature (cut-out T3 probe fitted), which can be activated only in heating mode or heating and cooling mode.
- Automatic switch of the operating mode by means of T2 water probe (optional) applied on the 2 pipe system.
- Seasonal switch by means of remote contact.
- ON/OFF of the fan coil by means of the remote contact (window or clock contact).
- Electric heater control.

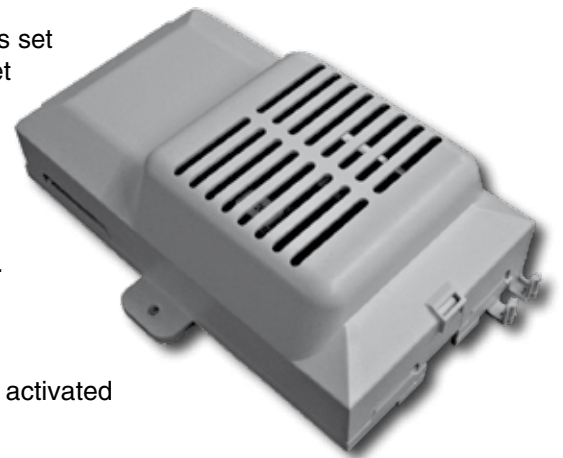

By activating the cut-out T3 probe function, the fan is stopped in winter when the coil temperature is lower than 32°C and started when the temperature reaches 36°C. In summer mode, the fan stops when the temperature inside the coil exceeds 22°C and starts when it drops below 18°C.

The following connections are located on the power board:

- Receiver for infra-red remote control.
- T-MB control.
- RS 485 serial connection to manage several fan coils in Master/Slave configuration or to create a supervisory network.

NTC sensor included for T1 function (return air control).

NTC sensor included for T3 function (low temperature cut-out thermostat).

NTC sensor (option) for T2 function (summer/winter switch).

Controls and units **MB** version

T-MB control

DESCRIPTION	IDENTIFICATION	CODE
Wall control (to be used with MB board only)	T-MB	9066331E
Control fitted on the unit, for CV / CVB models (to be used with MB board only) - SECIF-ECM only	T-MB-LM	9066646
Control supplied with separate packaging, for CV / CVB models (to be used with MB board only) - SECIF-ECM only	T-MB-LS	9066645
Control fitted on the unit, for CV / CVB models (UP-AU included) - SECIF-ECM only	T-MB-M-UP	9066675
Control supplied with separate packaging, for CV / CVB models (UP-AU included) - SECIF-ECM only	T-MB-S-UP	9066674

Control with display that allows controlling one or more units in Master/Slave mode. The control is equipped with internal sensor to detect the room temperature, which can be defined as a priority compared to the return air sensor on the fan coil.

The **T-MB** control

features the following functions:

- Switch the appliance ON and OFF.
- Temperature set.
- Modify the set point (when used as a +/- 3° variation of the set point configured from NET supervisory program or PSM-DI).
- Set the fan speed (low, medium, high or autofan).
- Set the operation mode (fan only, cooling, heating; auto for 4 pipe systems with mode selection depending on the air temperature).
- Time setting.
- Weekly ON/OFF program.
- Display and change of the fan coil operation parameters.



Dimensions: 110x72x25 mm

Controls and units **MB version**

RT03 infra-red remote control

DESCRIPTION	IDENTIFICATION	CODE
RT03 infra-red remote control with receiver supplied with separate packaging (to be used with MB board only)	RS-RT03	9066337
RT03 infra-red remote control supplied with separate packaging (to be used with MB board only)	RT03	3021203
Receiver for RT03 infra-red remote control supplied with separate packaging (to be used with MB board only)	RS	9066338

The infra-red remote control allows setting by a remote position the fan coil operation parameters.

The **RT03** infra-red remote control features the following functions:

- Switch the appliance ON and OFF.
- Temperature set.
- Set the fan speed (low, medium, high or autofan).
- Set the operation mode (fan only, cooling, heating; auto for 4 pipe systems with mode selection depending on the air temperature).
- Time setting.
- 24 hours ON/OFF program.

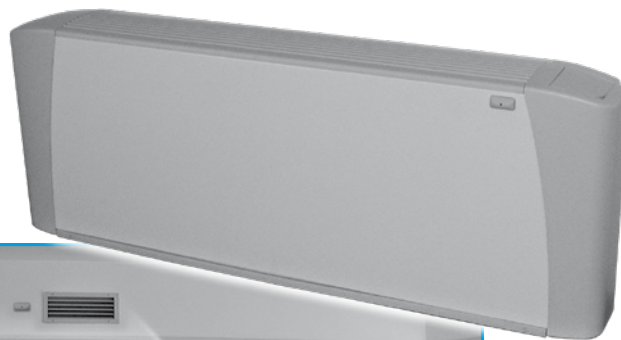

**INSTALLATION EXAMPLE
WITH INFRA-RED REMOTE CONTROL**

Controls and units **MB** version

A group of **SEC/F-ECM** units with **MB** electronic board can be connected via a serial link and can consequently be managed at the same time by just one **T-MB** control or **RT03** infra-red remote control. Using the special jumper present on the **MB** board, one unit must be configured as the master, and all the others as slaves. It is clear that the remote control must be pointed at the receiver on the master unit. To avoid problems, it is recommended to install and connect the receiver only on the master unit.

With T-MB control

One control for each unit

(MAXIMUM LENGTH OF THE CONNECTION CABLE = 20 m)



One control for more units (20 units max.)

(MAXIMUM TOTAL LENGTH OF THE CONNECTION CABLE = 800 m)

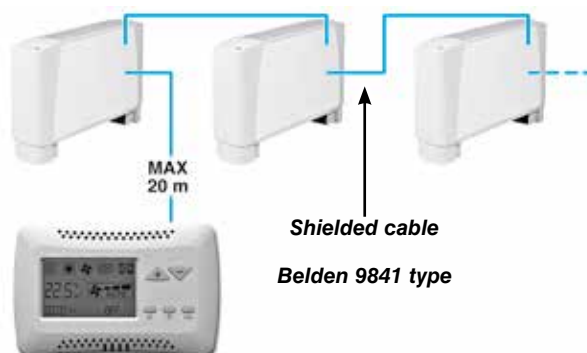

With RT03 infra-red remote control

One control for each unit



One control for more units (20 units max.)

(MAXIMUM TOTAL LENGTH OF THE CONNECTION CABLE = 800 m)

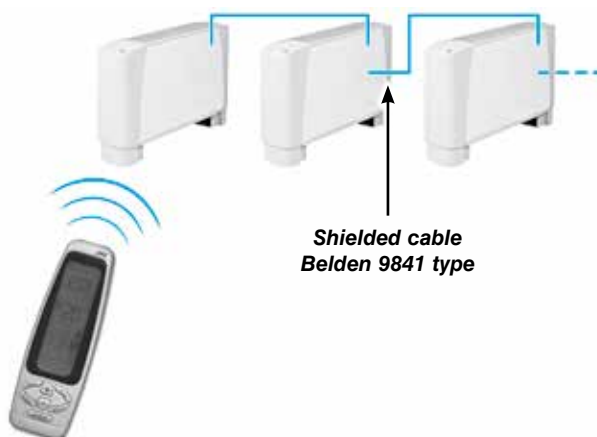

T2 accessory for units with MB electronic board

IDENTIFICATION	CODE
T2	9025310

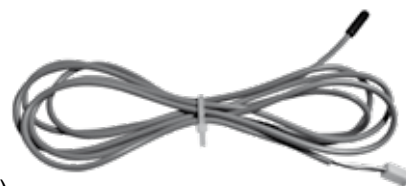

The T2 sensor can be combined with MB boards to be placed on the water supply pipe upstream 3 way valves (not to be used with 2 way valve).

The T2 sensor must be used as described below:

- Change-Over for 2-pipe system for the automatic switch of the operating mode.
If water temperature is lower than 20°C, cooling mode is set; on the other hand, if water temperature exceeds 30°C, heating mode is set.
- It can be used on units with electric heater and hot water supply. The T2 priority probe activates the electric heater or water valve, depending on the water temperature detected. If water temperature exceeds 34°C, the water valve ON-OFF control is activated; on the other hand, if water temperature is lower than 30°C, the electric heater is activated.

Controls and units **MB version**

PSM-DI multifunction control panel

DESCRIPTION	IDENTIFICATION	CODE
Multifunction control (to be used with MB board only)	PSM-DI	3021293

Another option available for the serial communication between the units is the possibility to connect up to 60 **SEC/F-ECM** units in series and manage them with just one wall mounted **PSM-DI** controller. The wall mounted controller can be used to set the operating mode for each individual unit connected, display the operating conditions of each individual unit, and set the ON/OFF time sets for each day of the week (the program can be set for all the units and for a maximum of ten groups of units).

If more than 60 units need to be connected, two or more control panels must be used. Each unit must have a MB board. The **PSM-DI** control is used to manage a series of fan coils, up to a maximum of 60 units (the maximum length of the RS 485 connection cable must not exceed 800 m), from one single control point.



The **PSM-DI** control communicates via a serial line with all the units connected, with the possibility of controlling them all together or individually. In fact, the unique address of each individual fan coil means that all the units can be called at the same time, or the individual unit called, to perform the following functions:

- display the current operating mode, the fan speed, the set point;
- display the room temperature measured on the individual unit;
- turn all the units ON and OFF at the same time or alternatively each unit individually;
- change the operating mode (fan only, heating, cooling, automatic changeover);
- change the set point;
- modify the values and operation parameters of the fan speed.

Each function can then be sent to all the units connected, or alternatively to each individual unit.

Different set points or operating modes can be set for each individual unit.

The **PSM-DI** panel can also be used for the time management of the units over the week. Four ON times and four OFF times can be set on the units for each day of the week. A different temperature set that will be considered as Operation set for all connected appliances, can be set for each event. If the temperature set is not entered for the individual event, it must be set during programming for each individual unit or for the entire network.

Units without receiver or with receiver can be connected within the network: the former can receive instructions only from the **PSM-DI** wall mounted panel; while the latter can receive information from both the wall mounted panel (**PSM-DI**) and infra-red remote control. Use the infra-red remote control to force ON mode of the individual unit, if ON/OFF daily time programming has been set. The unit will regain the settings from the **PSM-DI** panel during execution of successive start-up program.

The PSM-DI panel cannot be used together with the NET management program (see next page).

Notes:

- set the Dip Switches of each fan coil as illustrated in the remote control installation manual, based on the required solutions.
- it is possible to connect only one single SIOS board per each PSM-DI control panel.
- about "Priority pump function": when just one unit calls for, the relay RL1 on the SIOS board is automatically activated to connect a hot water pump.
- the RS 485 network's overall length must not exceed 700/800 metres.

Controls and units **MB** version

T-DI Touch screen multifunction control panel

DESCRIPTION	IDENTIFICATION	CODE
T-DI Touch screen multifunction control panel	T-DI	9066685



The T-DI multifunction control panel lets supervise and control more units with MB or SIOS boards; the panel is equipped with a 7 inches touch screen display and a serie of graphical pages that allows an easy reading of the data sent by the fan coils and the management of up to 60 units (max. 60 units: SIOS + MB).

With the multifunction control panel T-DI it is also possible to control the units from a distance with the specific Cloud APP for android and iOS. The Cloud APP is simple to use and lets have complete control of all the connected units.

Web gateway for Cloud

DESCRIPTION	IDENTIFICATION	CODE
Web gateway for Cloud	Web gateway	9066892



With the Web gateway for “Cloud” it is possible to control from a distance up to 60 units, equipped with MB or SIOS boards (max. 60 units: SIOS + MB), with the specific APP for android and iOS.

The “Cloud” APP is simple to use and lets have complete control of all the connected units.

Management system for a network of fan coils

NET program for managing a network of MB fan coils

DESCRIPTION	IDENTIFICATION	CODE
Hardware/software supervisory system (to be used with MB board and MB versions only)	NET	9079118

NET is a centralised control system for networks of MB fan coils, based on software that runs on LINUX™ operating system (the program is provided pre-installed on a PC) and it works in a “stand alone” way, as an ordinary computer, so that it can be connected to a monitor, to a mouse and to a keyboard. By connecting an Ethernet cable is instead possible to work at a distance and visualize the entire program setting-up through whatever browsers. The NET software offers a practical and economical solution for managing the units, with the simple click of the mouse.

The main characteristics are:

- simplicity of use;
- an extremely complete and functional weekly program;
- possibility to access the historical operating data for each individual unit connected;
- possibility of data saving on USB key;
- visualization of the saved configuration on a new ASUS PC.



The program can be used to:

- Create uniform groups (groups of units on individual floors, in offices or rooms).
- Save weekly programs configured for different types of operation (summer, winter, mid seasons, closing periods etc.); these can then be recalled and activated with a simple click of the mouse. Weekly on/off cycles can be set for individual units or groups of units.
- Set the operating conditions for each individual unit or groups of units (operating mode, fan speed, temperature setting).
- Set the set point limits for each individual unit or groups of units.
- Switch each individual unit or groups of units ON or OFF.

With the NET multifunction control panel it is also possible to control the units remotely with the specific Cloud App for Android and iOS.

The Cloud APP is simple to use and lets have complete control of all the connected units.

Graphical pages

The main program screen can display and interact with the entire network of units.

An individual unit, a group of units or the entire network can be called so as to make modifications to the operating mode and the set point.

The user can then check the operating status of each individual unit, read the room temperature, the coil temperature and the operating status of the condensate drain pumo or any alarms.

The “Monitor” Screen shows the units that are connected to the network and scanned by the program.

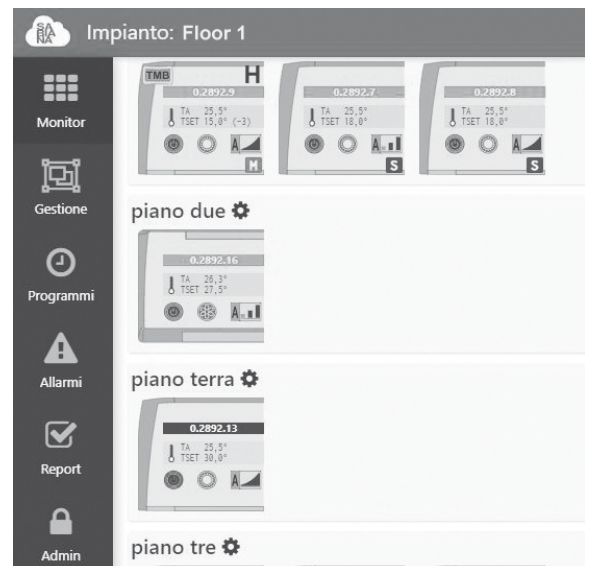

Management system for a network of fan coils

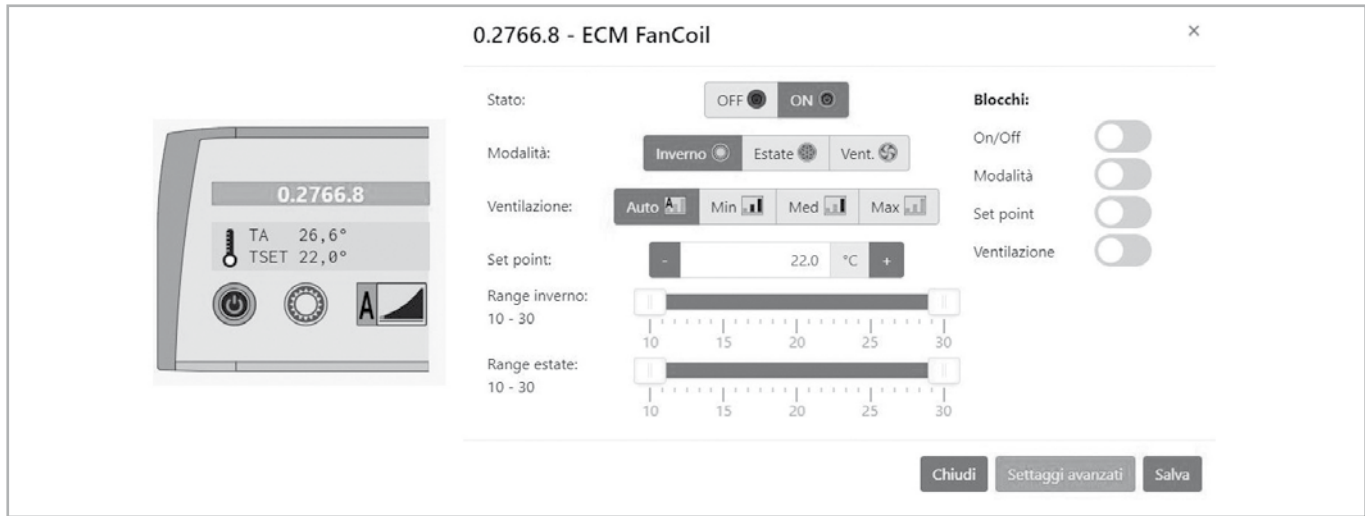

The icon of the terminal unit provides the following information:

- Unit name (00.01.01)
- Set temperature (SETP)
- Room temperature (AT)
- Unit status:



ON



OFF

- Mode:



Summer



Winter



Auto



Fan only

- Fan speed:



Low



Medium



High



Auto Fan

The “Programmi” Screen, can be used to set the unit operating parameters for each day of the week. Several weekly programs can be set. Time bands are available for each day of the week. The time and the type of operation to be performed by the unit can be set for each band. The time and the operating parameters can then be displayed before being sent to the unit and implemented.

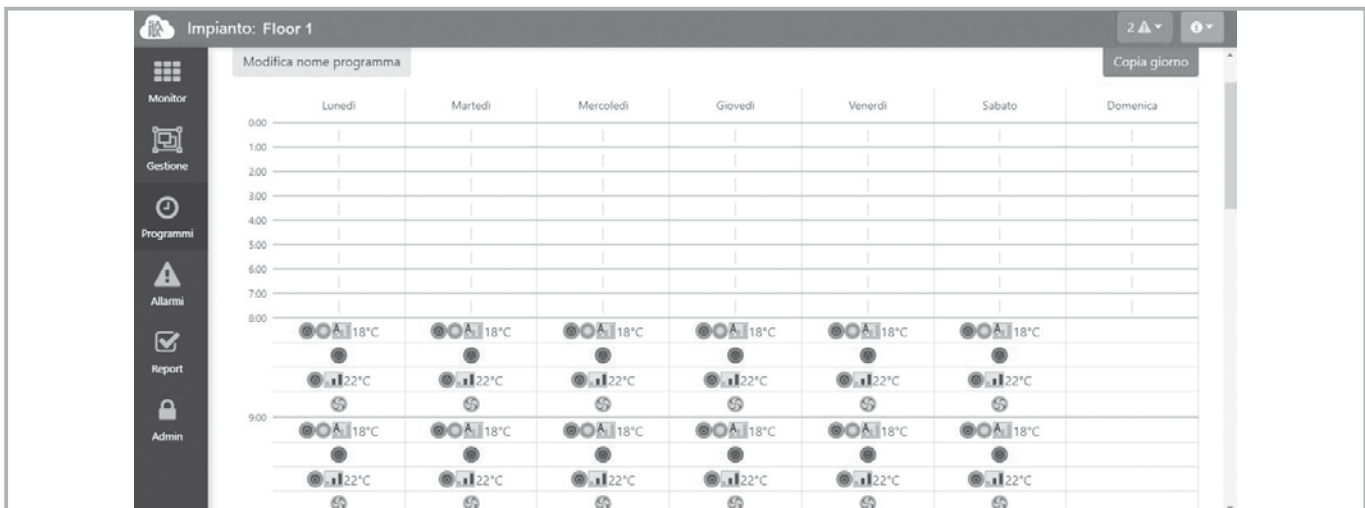

Management system for a network of fan coils

Every time that the reading of the set up Dip Switches results not easy (as for example by the false ceiling installations), it is always possible to display them directly through the NET program.

The screenshot shows a configuration window for 'camera 54 - 0.2892.10 - ECM FanCoil'. At the top, there are three tabs: 'Stato unità', 'Configurazione', and 'Parametri'. The 'Configurazione' tab is active, displaying a grid of 10 dip switches, all of which are currently in the 'ON' position. Below the grid is a table mapping each dip switch number to its 'OFF option' and 'ON option'.

Dip	OFF option	ON option
1: OFF	Impianto a 2 tubi	Impianto a 4 tubi
2: OFF	Termostatazione con valvole	Termostatazione con Fan
3: OFF	T3 disabilitata	T3 abilitata
4: OFF	T3 solo Inverno quando abilitata	T3 Inverno ed Estate quando abilitata
5: OFF	Ventilazione continua	Ventilazione contemporanea delle valvole
6: OFF	IAQ	Gestione Resistenze
7: OFF	T2 come Change-Over CH (resistenza II° gradino)	Gestione Resistenze con T2
8: OFF	RL7 (D0-D0) abbinato allo stato del controllore	--
9: OFF	CA = ON/OFF remoto	CA = Estate/Inverno remoto
10: OFF	Master	Slave

The screenshot shows the 'Parametri' (Parameters) tab for the same unit. It displays several adjustable parameters with minus and plus buttons for each. The parameters are:

- T3 ventilatore ON riscaldamento: 34.0 °C
- Isteresi T3 per ventilatore: 5.0 °C
- Tempo ON antistratificazione: 60 sec.
- ECM tensione velocità minima: 1.0 V
- ECM tensione velocità massima: 10.0 V
- T3 ventilatore ON raffreddamento: 22.0 °C
- Tempo massimo OFF ventilatore per antistratificazione: 10 min.
- Tempo post ventilazione: 180 sec.
- ECM tensione velocità media: 5.0 V
- Offset sonda T-MB: 0.0 °C

At the bottom, there are three buttons: 'Chiudi', 'Reset parametri', and 'Salva'.

In addition to the alarm set on the "Alarms" Screen, it is possible to send the ON-OFF alarm notification via E-mail and sms.

The screenshot shows the 'Impianto: Floor 1' interface. The 'Allarmi' (Alarms) section is active, displaying a table of alarm events and their notification settings. The table has columns for 'Tipo evento', 'eMail', and 'Invia alla disattivazione'.

Tipo evento	eMail	Invia alla disattivazione
Unità in allarme [qualsiasi]	All'attivazione invia: immediatamente	No
Unità in allarme condensa	All'attivazione invia: mai	No
Unità in allarme sonda	All'attivazione invia: mai	No
Unità persa	All'attivazione invia: mai	No
0.2892.6.1	All'attivazione invia: mai	No
0.2892.6.2	All'attivazione invia: mai	No

Management system for a network of fan coils

RS 485 serial connection cable

Shielded cable to be used: Belden 9841, RS-485, 1x2x24 AWG SFTP, 120 Ohm.



PC NET Software

Installation example with a SkyStar network with MB board.

(*) In the event of more than 60 units, add one or more Router-S (see next page).

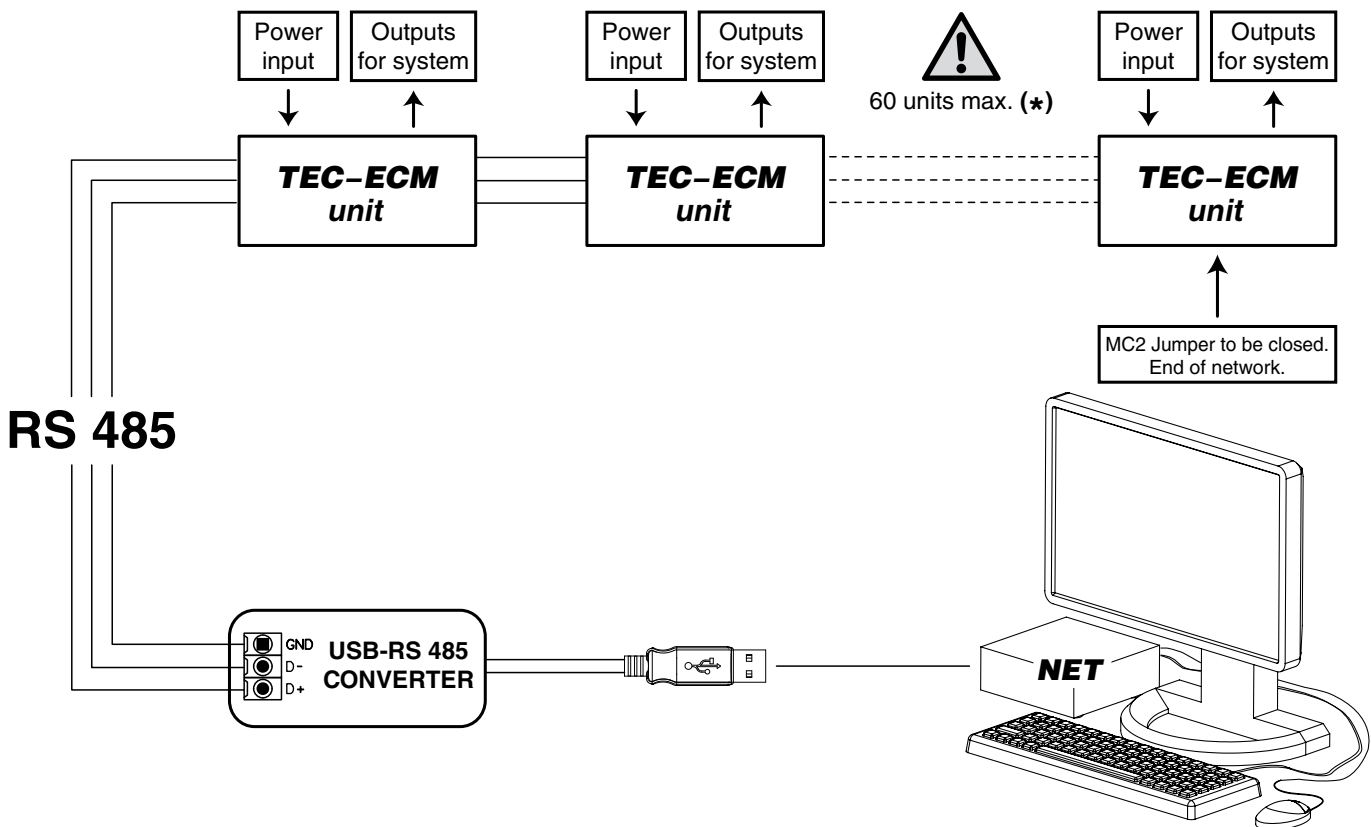

IDENTIFICATION	CODE
SIOS	3021292

The SIOS is a board equipped with 8 relays with potential free contact to control the activation or deactivation of remote electric utilities. Moreover, the board has 8 digital inlets to display the actuators or external consents, such as motor or other.

The SIOS boards can be connected:

- inside a network managed by Sabianet.
- inside a network managed by T-DI.
- inside a network managed by SabWeb.
- to a PSM-DI panel (one SIOS for each PSM-DI panel).

For certified electronic KNX boards, contact the Sabiana technical department.



IDENTIFICATION	CODE
Router-S	3021290

The Router-S is an electronic board that allows to control several units inside a network managed by NET (default) or within a sub-network managed by BMS systems, that are not provided by York (it is necessary to operate on a Dip Switch on the board).

Managed by NET

The Router-S in the standard version is an electronic board that:

- allows creating networks with more than 60 units (minimum 2 Router-S are required) or to divide the network (per floor, building, ecc.).
- allows creating a Master/Slave sub-network to be controlled as an independent group.

The number of Router-S to be used is:

- up to 60 units: no Router-S.
- from 61 to 120 units: 2 Router-S.
- every 60 subsequent units: 1 additional Router-S.

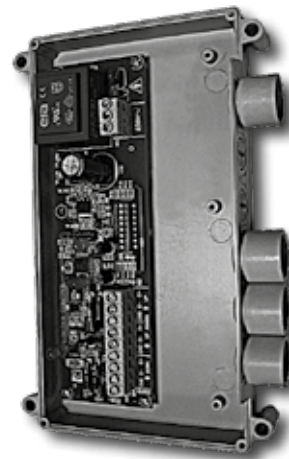

Managed by BMS Systems which are not provided

The Router-S becomes an electronic board to use with BMS systems (not by Sabiana), only after having set the Dip Switch on the board and so creating a Master/Slave sub-network to be controlled as an independent group.

The number of Router-S to be used is:

- maximum 14 Router-S.
- maximum 15 Fan Coils per Router-S.

The descriptions and illustrations provided in this publication are not binding: we reserve the right, whilst maintaining the essential characteristics of the types described and illustrated, to make, at any time, without the requirement to promptly update this piece of literature, any changes that it considers useful for the purpose of improvement or for any other manufacturing or commercial requirements.

