

CONTENTS

SEC/OW

- Main components
- Dimensions, Weight, Water content
- Technical features
- Working conditions and Air throw
- Emissions
- Water side pressure drop
- Accessories
- Control operations
- Wall electronic controls
- Speed switches
- Electronic control accessories
- Wireless control system
- Controls and units MB version for SEC/OW units

SEC/OW-ECM

- Main components
- Dimensions, Weight, Water content
- Technical features
- Working conditions and Air throw
- Emissions
- Water side pressure drop
- Accessories
- ECM configuration
- ECM wall electronic controls
- ECM electronic control accessories

SEC/OW and SEC/OW-ECM

- Controls and units MB version
- Management system for a network of units

Page 3
Page 4
Page 6
Page 7
Page 8
Page 12
Page 13
Page 19
Page 20
Page 22
Page 23
Page 24

Page 26

Page 27
Page 28
Page 30
Page 31
Page 32
Page 36
Page 37
Page 39
Page 40
Page 41

Page 42
Page 48

INTRODUCTION

Thanks to the particular air handling section, **SEC/OW** cassette units generate an airflow with a “coanda” effect. The unit is suitable for installation in a suspended ceiling. Air intake is from the bottom while the air supply is parallel to the ceiling, through practical and functional intake and outlet grids.

The “coanda” effect creates excellent circulation of the air inside the room.

In addition to the traditional AC asynchronous motors are available a innovative electronic motors with extremely low energy consumption, controlled by an inverter board and identified by **ECM**.

The EC motors allow to decrease electric consumption by more than 50% compared to traditional AC asynchronous motors. They enable to control the air flow continuously and the ambient temperature with precision, with further benefits in terms of very low noise levels thanks to the reduced average working speed.

Every unit can be supplied with 1 coil (2 pipe system) and possibly an electric heating element, or with 2 coils (4 pipe system) with one or two rows, for water supply at a low temperature.

Fresh air may be mixed with room air.

A condensate pump may also be supplied as an accessory.

In addition to the conventional temperature and speed control systems, there is also the possibility to control operation of each unit through a single remote control with central supervisor software installed on a PC (NET).

With AC asynchronous motor units it is also possible to use the completely wireless electronic control system based on radio communication, **FREE**, with great advantages in terms of installation flexibility and maximum precision in measuring room temperature.

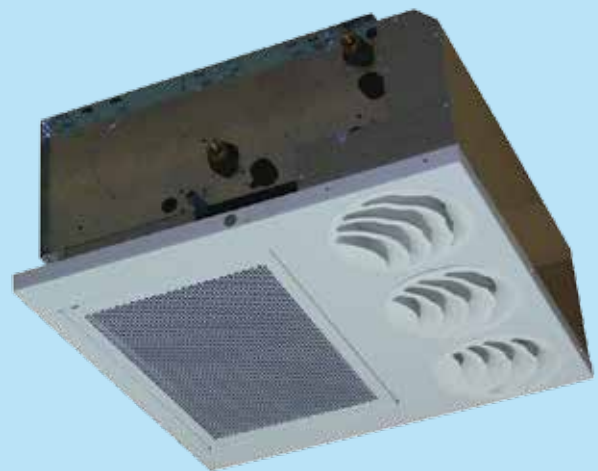

CONSTRUCTIONAL FEATURES OF THE MAIN COMPONENTS

Casing

Made from 1 mm galvanized steel insulated with polyolefin (PO) foam (class M1).

Diffuser with intake grille

In prepainted metal sheet in RAL 9003 colour with intake grille that can be opened for inspection and maintenance of the air filter.

Air Filter

Polypropylene cellular fabric regenerating filter.

Fan Assembly

The fans have aluminium or plastic blades directly keyed on the motor with double aspiration and they are dynamically and statically balanced during manufacture in order to have an extremely quiet operation.

Electric motor

The motor is wired for single phase and has six speeds, three of which are connected, with capacitor. The motor is fitted on sealed for life bearings and is secured on anti-vibration and self-lubricating mountings. Internal thermal protection with automatic reset, protection IP 20, class B.

The speeds connected in the factory are indicated by “MIN, MED and MAX” in the following tables.

Heat exchange coil

It is manufactured from drawn copper tube and the aluminium fins are mechanically bonded onto the tube by an expansion process. The coil has two 1/2 inch BSP internal connections and 1/8 inch BSP air vent and drain.

The heat exchanger is not suitable for use in corrosive atmosphere or in environments where aluminium may be subject to corrosion.

The connection side cannot be changed on site.

Condensate Collection Tray

Made of “L”-shaped plastic (ABS UL94 HB) fitted on the inner casing; the tray is insulated with polyolefin (PO) foam (class M1). The outside diameter of the condensate discharge pipe is 15mm.

Round diffuser

The SEC/OW one-way cassette units are supplied with round diffusers suitably designed to generate an airflow with “coanda” effect. The direction of diffuser air flow can be adjusted on site.

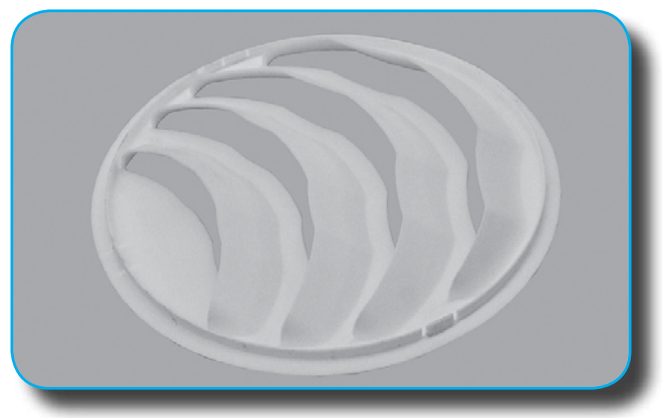

SEC/OW Gr 1 - 3 diffusers

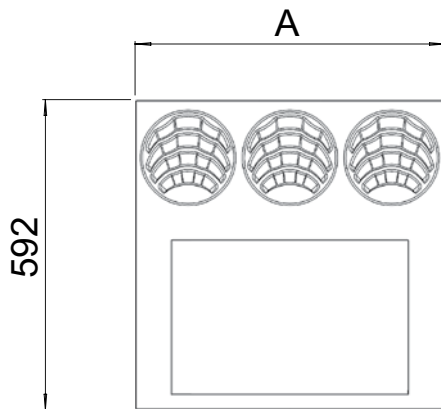

SEC/OW Gr 2 - 5 diffusers

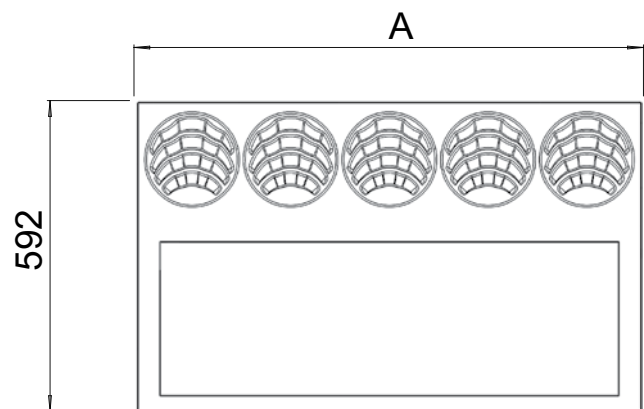

SEC/OW Gr 3 - 6 diffusers

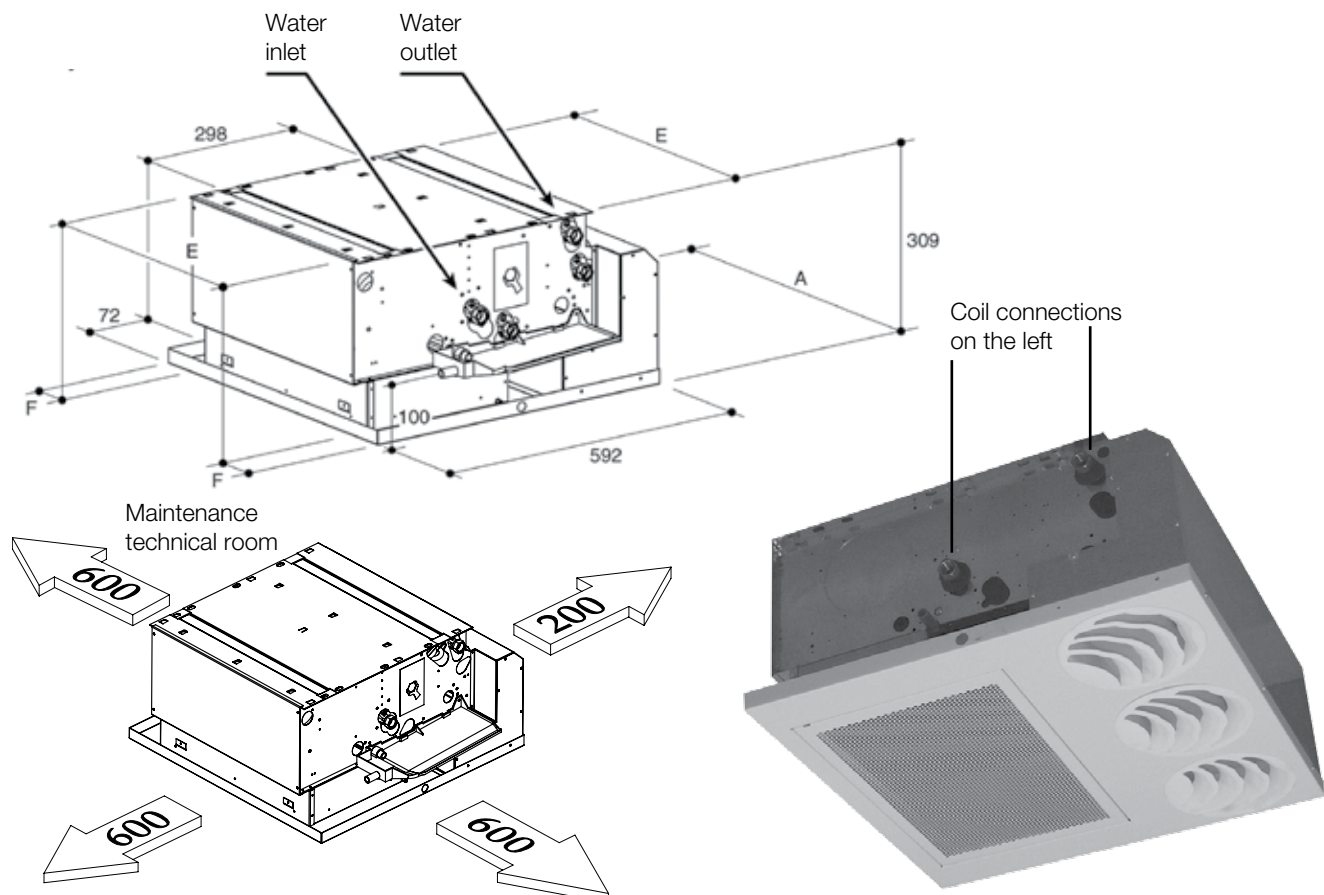
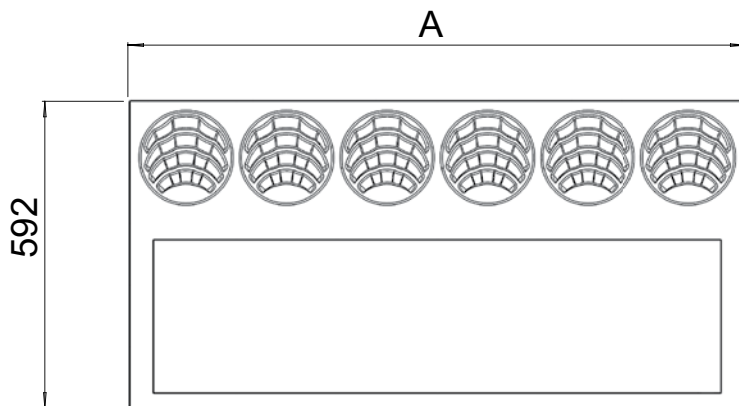

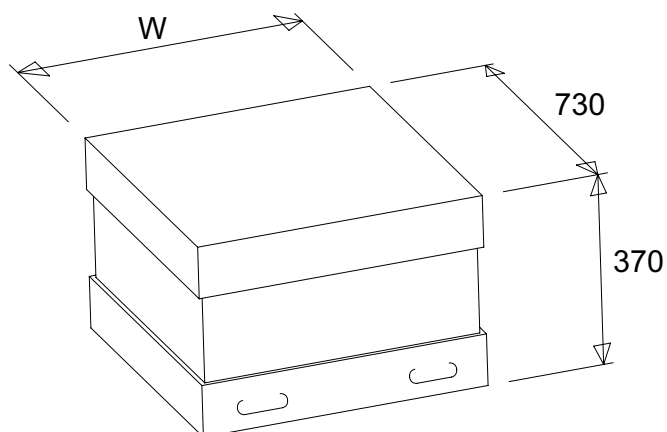

DIMENSIONS (mm)

<i>MODEL</i>	1	2	3
A	592	970	1192
E	454	884	1099
F	78	43	46,5
W	750	1130	1350

WEIGHT (kg)

<i>MODEL</i>		<i>Weight packed unit</i>			<i>Weight unpacked unit</i>		
		1	2	3	1	2	3
ROWS	3	18	34	44	16	33	42
	3+1	20	40	51	19	38	48
	3+2	23	46	58	22	43	54
	4	20	37	48	18	35	45
	4+1	23	42	54	21	40	51

WATER CONTENT (l)

<i>MODEL</i>		1	2	3
ROWS	3	0,6	1,3	1,7
	4	0,8	1,7	2,4
	+1	0,2	0,4	0,5
	+2	0,4	0,8	1,0

2-pipe units

The following standard rating conditions are used:

COOLING (summer operation)

Entering air temperature: + 27°C d.b. / + 19°C w.b.

Water temperature: + 7°C E.W.T. / + 12°C L.W.T.

HEATING (winter operation)

Entering air temperature: + 20°C

Water temperature: + 50°C E.W.T.

Water flow rate as for the cooling conditions

MODEL		SEC/OW 1.3-2T						SEC/OW 2.3-2T						SEC/OW 3.3-2T						
		1	2	3	4	5	6	1	2	3	4	5	6	1	2	3	4	5	6	
Speed		MIN	MED			MAX		MIN	MED			MAX		MIN		MED	MAX			
Air flow	m³/h	140	180	220	245	280	305	200	240	305	380	470	560	290	360	440	540	620	680	
Cooling total emission	kW	0,88	1,06	1,26	1,35	1,50	1,60	1,37	1,62	1,97	2,37	2,81	3,23	1,97	2,37	2,84	3,34	3,75	4,05	
Cooling sensible emission	kW	0,66	0,81	0,98	1,06	1,18	1,27	1,00	1,19	1,47	1,77	2,13	2,47	1,44	1,74	2,11	2,51	2,83	3,07	
Heating	kW	1,08	1,33	1,59	1,73	1,93	2,08	1,60	1,91	2,35	2,86	3,43	3,95	2,30	2,79	3,37	4,02	4,53	4,88	
ΔP Cooling	kPa	2,4	3,3	4,5	5,1	6,1	6,8	2,9	3,9	5,5	7,6	10,3	13,1	6,4	8,8	12,1	16,2	19,8	22,7	
ΔP Heating	kPa	1,8	2,6	3,5	4,0	4,9	5,6	2,3	3,1	4,5	6,3	8,4	10,8	5,2	7,3	9,8	13,4	16,3	18,6	
Fan	W	16	22	32	38	49	66	24	27	34	44	57	71	27	33	42	59	72	84	
Sound power	Lw	dB(A)	35	41	46	49	52	55	33	36	42	48	54	57	35	41	46	52	55	57
Sound pressure (*)	Lp	dB(A)	26	32	37	40	43	46	24	27	33	39	45	48	26	32	37	43	46	48

MODEL		SEC/OW 1.4-2T						SEC/OW 2.4-2T						SEC/OW 3.4-2T						
		1	2	3	4	5	6	1	2	3	4	5	6	1	2	3	4	5	6	
Speed		MIN	MED			MAX		MIN	MED			MAX		MIN		MED	MAX			
Air flow	m³/h	140	180	220	245	280	305	200	240	305	380	470	560	290	360	440	540	620	680	
Cooling total emission	kW	0,97	1,19	1,44	1,55	1,74	1,87	1,44	1,72	2,12	2,57	3,09	3,58	2,05	2,49	3,00	3,56	4,02	4,36	
Cooling sensible emission	kW	0,71	0,88	1,07	1,17	1,31	1,42	1,04	1,24	1,54	1,88	2,28	2,67	1,48	1,81	2,20	2,63	2,98	3,25	
Heating	kW	1,14	1,42	1,72	1,88	2,10	2,27	1,69	2,03	2,54	3,12	3,79	4,44	2,38	2,90	3,51	4,20	4,77	5,20	
ΔP Cooling	kPa	4,7	6,7	9,2	10,6	12,9	14,6	4,4	6,0	8,6	12,1	16,8	21,7	4,7	6,7	9,3	12,6	15,5	17,9	
ΔP Heating	kPa	3,7	5,4	7,6	8,8	10,7	12,3	3,5	4,8	7,1	10,2	13,6	17,9	3,9	5,5	7,3	10,0	12,6	14,6	
Fan	W	16	22	32	38	49	66	24	27	34	44	57	71	27	33	42	59	72	84	
Sound power	Lw	dB(A)	35	41	46	49	52	55	33	36	42	48	54	57	35	41	46	52	55	57
Sound pressure (*)	Lp	dB(A)	26	32	37	40	43	46	24	27	33	39	45	48	26	32	37	43	46	48

4-pipe units

The following standard rating conditions are used:

COOLING (summer operation)

Entering air temperature: + 27°C d.b. / + 19°C w.b.

Water temperature: + 7°C E.W.T. / + 12°C L.W.T.

HEATING (winter operation)

Entering air temperature: + 20°C

Water temperature: + 70°C E.W.T. / + 60°C L.W.T.

MODEL		SEC/OW 1.3-4T						SEC/OW 2.3-4T						SEC/OW 3.3-4T						
		1	2	3	4	5	6	1	2	3	4	5	6	1	2	3	4	5	6	
Speed		MIN	MED			MAX		MIN	MED			MAX		MIN		MED	MAX			
Air flow	m³/h	140	180	220	245	280	305	200	240	305	380	470	560	290	360	440	540	620	680	
Cooling total emission	kW	0,88	1,06	1,26	1,35	1,50	1,60	1,37	1,62	1,97	2,37	2,81	3,23	1,97	2,37	2,84	3,34	3,75	4,05	
Cooling sensible emission	kW	0,66	0,81	0,98	1,06	1,18	1,27	1,00	1,19	1,47	1,77	2,13	2,47	1,44	1,74	2,11	2,51	2,83	3,07	
Heating	kW	0,92	1,08	1,25	1,34	1,47	1,56	1,49	1,71	2,02	2,35	2,73	3,07	2,12	2,47	2,87	3,30	3,64	3,89	
ΔP Cooling	kPa	2,4	3,3	4,5	5,1	6,1	6,8	2,9	3,9	5,5	7,6	10,3	13,1	6,4	8,8	12,1	16,2	19,8	22,7	
ΔP Heating	kPa	1,6	2,1	2,7	3,1	3,6	4,0	0,9	1,2	1,6	2,0	2,6	3,2	2,0	2,6	3,4	4,3	5,1	5,8	
Fan	W	16	22	32	38	49	66	24	27	34	44	57	71	27	33	42	59	72	84	
Sound power	Lw	dB(A)	35	41	46	49	52	55	33	36	42	48	54	57	35	41	46	52	55	57
Sound pressure (*)	Lp	dB(A)	26	32	37	40	43	46	24	27	33	39	45	48	26	32	37	43	46	48

MIN-MED-MAX = Standard connected speeds.

(*) = The sound pressure levels are 9 dB(A) lower than the sound power levels and apply to the reverberant field of a 100 m³ room and a reverberation time of 0.5 sec.

WORKING CONDITIONS

Max. entering water temperature..... + 80 °C
 Min. entering water temperature..... + 5 °C
 for entering water temperatures below + 5°C, contact our technical department
 Max. rated pressure 1000 kPa (10 bars)

Installation height (m)

MODEL	1	2	3
Minimum	2,6	2,6	2,6
Maximum	3,2	3,2	3,5

Water flow limits for main coil (l/h)

MODEL	3 rows			4 rows		
	13	23	33	14	24	34
Minimum	100	150	150	100	150	200
Maximum	500	1000	1500	750	1000	2000

Water flow limits for additional coil (l/h)

MODEL	1 row			2 rows		
	1	2	3	1	2	3
Minimum	50	100	100	50	100	100
Maximum	250	450	650	250	450	650

Motor electrical data (max. absorption)

MODEL		1	2	3
230/1 50Hz	W	66	71	84
	A	0,30	0,32	0,38

AIR THROW

C1 - Heating

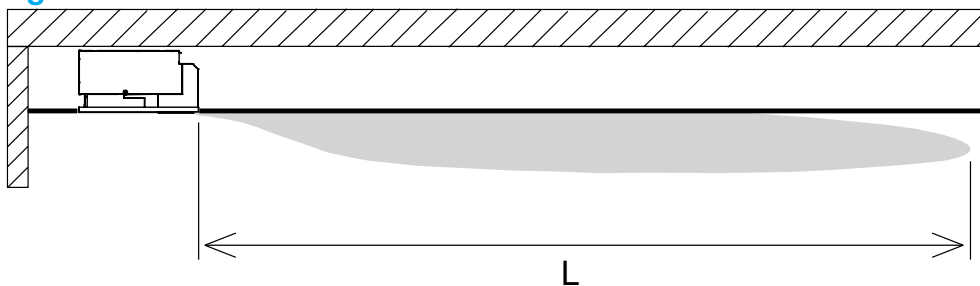

C2 - Cooling

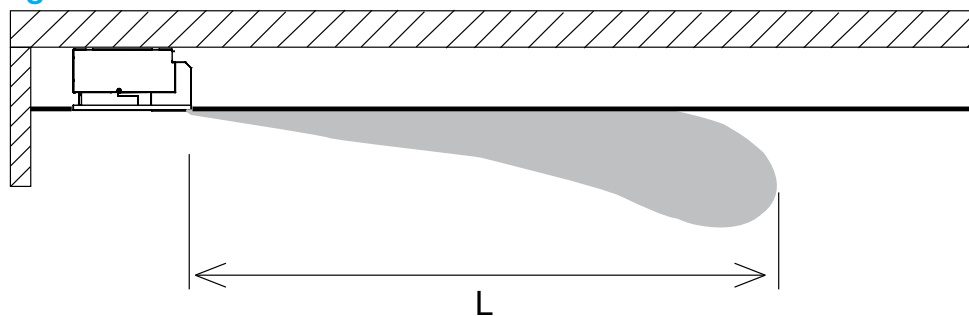

MODEL		SEC/OW 1						SEC/OW 2						SEC/OW 3					
		1	2	3	4	5	6	1	2	3	4	5	6	1	2	3	4	5	6
Air throw L (m)	C1	3,8	4,5	5,8	6,3	6,8	7,2	4	5	6,1	7	8	9	4,5	5,2	6,3	7,5	8,8	9,5
	C2	3	3,6	4,6	5	5,4	5,7	3,2	4	4,8	5,6	6,4	7,2	3,6	4,1	5	6	7	7,6

Cooling emission of 3 row coil

Entering air temperature: +27°C - Relative Humidity: 50%

Model	Speed	Qv m³/h	WT: 7/12 °C				WT: 8/13 °C				WT: 10/15 °C				WT: 12/17 °C			
			Pc kW	Ps kW	Qw l/h	Dp(c) kPa	Pc kW	Ps kW	Qw l/h	Dp(c) kPa	Pc kW	Ps kW	Qw l/h	Dp(c) kPa	Pc kW	Ps kW	Qw l/h	Dp(c) kPa
SEC/OW 1.3-2T	VI	305	1,73	1,27	298	7,8	1,54	1,19	265	6,3	1,14	1,04	196	3,7	0,91	0,91	157	2,5
	V MAX	280	1,62	1,18	279	7,0	1,44	1,11	248	5,6	1,07	0,97	184	3,3	0,85	0,85	146	2,2
	IV	245	1,46	1,06	251	5,8	1,30	0,99	224	4,7	0,97	0,86	167	2,8	0,76	0,76	131	1,8
	III	220	1,36	0,97	234	5,1	1,21	0,92	208	4,2	0,91	0,80	157	2,5	0,70	0,70	120	1,5
	II MED	180	1,14	0,81	196	3,8	1,02	0,76	175	3,1	0,77	0,66	132	1,8	0,59	0,59	101	1,1
	I MIN	140	0,95	0,66	163	2,7	0,85	0,62	146	2,2	0,64	0,54	110	1,3	0,48	0,48	83	0,8
SEC/OW 2.3-2T	VI	560	3,47	2,46	597	14,9	3,12	2,32	537	12,2	2,36	2,02	406	7,4	1,78	1,78	306	4,4
	V	470	3,03	2,13	521	11,7	2,72	2,00	468	9,6	2,06	1,74	354	5,8	1,54	1,54	265	3,4
	IV MAX	380	2,54	1,77	437	8,6	2,29	1,66	394	7,1	1,74	1,45	299	4,3	1,28	1,28	220	2,5
	III	305	2,12	1,46	365	6,3	1,91	1,37	329	5,2	1,46	1,19	251	3,2	1,06	1,06	182	1,8
	II MED	240	1,74	1,19	299	4,4	1,57	1,12	270	3,6	1,20	0,97	206	2,2	0,86	0,86	148	1,2
	I MIN	200	1,47	1,00	253	3,3	1,32	0,94	227	2,7	1,02	0,81	175	1,7	0,72	0,72	124	0,9
SEC/OW 3.3-2T	VI	680	4,36	3,06	750	25,8	3,91	2,88	673	21,2	2,98	2,51	513	13,0	2,22	2,22	382	7,6
	V	620	4,03	2,82	693	22,5	3,63	2,65	624	18,6	2,77	2,31	476	11,4	2,04	2,04	351	6,6
	IV MAX	540	3,59	2,50	617	18,4	3,23	2,35	556	15,2	2,47	2,05	425	9,3	1,81	1,81	311	5,3
	III MED	440	3,05	2,10	525	13,8	2,75	1,98	473	11,4	2,11	1,72	363	7,0	1,52	1,52	261	3,9
	II	360	2,55	1,74	439	10,0	2,30	1,64	396	8,3	1,77	1,42	304	5,2	1,26	1,26	217	2,8
	I MIN	290	2,11	1,44	363	7,2	1,91	1,35	329	6,0	1,47	1,17	253	3,7	1,04	1,04	179	2,0

Entering air temperature: +26°C - Relative Humidity: 50%

Model	Speed	Qv m³/h	WT: 7/12 °C				WT: 8/13 °C				WT: 10/15 °C				WT: 12/17 °C			
			Pc kW	Ps kW	Qw l/h	Dp(c) kPa	Pc kW	Ps kW	Qw l/h	Dp(c) kPa	Pc kW	Ps kW	Qw l/h	Dp(c) kPa	Pc kW	Ps kW	Qw l/h	Dp(c) kPa
SEC/OW 1.3-2T	VI	305	1,53	1,19	263	6,3	1,34	1,12	230	5,0	0,99	0,99	170	2,9	0,83	0,83	143	2,1
	V MAX	280	1,43	1,11	246	5,6	1,26	1,04	217	4,4	0,92	0,92	158	2,5	0,77	0,77	132	1,8
	IV	245	1,30	0,99	224	4,7	1,14	0,93	196	3,7	0,80	0,80	138	2,0	0,69	0,69	119	1,5
	III	220	1,21	0,92	208	4,1	1,06	0,86	182	3,3	0,75	0,74	129	1,7	0,64	0,64	110	1,3
	II MED	180	1,02	0,76	175	3,1	0,90	0,71	155	2,4	0,63	0,61	108	1,3	0,54	0,54	93	1,0
	I MIN	140	0,84	0,62	144	2,2	0,74	0,58	127	1,8	0,53	0,50	91	1,0	0,44	0,44	76	0,7
SEC/OW 2.3-2T	VI	560	3,10	2,32	533	12,2	2,74	2,17	471	9,7	1,96	1,87	337	5,3	1,63	1,63	280	3,8
	V	470	2,70	2,00	464	9,5	2,39	1,87	411	7,6	1,72	1,61	296	4,2	1,40	1,40	241	2,9
	IV MAX	380	2,27	1,67	390	7,1	2,01	1,56	346	5,7	1,46	1,34	251	3,2	1,18	1,18	203	2,1
	III	305	1,90	1,38	327	5,1	1,68	1,29	289	4,1	1,23	1,11	212	2,3	0,97	0,97	167	1,5
	II MED	240	1,55	1,12	267	3,6	1,38	1,05	237	2,9	1,01	0,90	174	1,7	0,79	0,79	136	1,0
	I MIN	200	1,31	0,94	225	2,7	1,17	0,88	201	2,2	0,86	0,75	148	1,2	0,66	0,66	114	0,8
SEC/OW 3.3-2T	VI	680	3,89	2,89	669	21,2	3,45	2,70	593	17,0	2,50	2,33	430	9,5	2,03	2,03	349	6,5
	V	620	3,60	2,66	619	18,5	3,20	2,49	550	14,9	2,32	2,15	399	8,4	1,87	1,87	322	5,6
	IV MAX	540	3,21	2,36	552	15,1	2,85	2,21	490	12,2	2,08	1,90	358	6,9	1,65	1,65	284	4,5
	III MED	440	2,73	1,98	470	11,3	2,42	1,85	416	9,1	1,78	1,60	306	5,2	1,40	1,40	241	3,4
	II	360	2,28	1,64	392	8,3	2,03	1,54	349	6,7	1,49	1,32	256	3,8	1,15	1,15	198	2,4
	I MIN	290	1,89	1,36	325	6,0	1,69	1,27	291	4,8	1,24	1,09	213	2,8	0,95	0,95	163	1,7

Entering air temperature: +25°C - Relative Humidity: 50%

Model	Speed	Qv m³/h	WT: 7/12 °C				WT: 8/13 °C				WT: 10/15 °C				WT: 12/17 °C			
			Pc kW	Ps kW	Qw l/h	Dp(c) kPa	Pc kW	Ps kW	Qw l/h	Dp(c) kPa	Pc kW	Ps kW	Qw l/h	Dp(c) kPa	Pc kW	Ps kW	Qw l/h	Dp(c) kPa
SEC/OW 1.3-2T	VI	305	1,34	1,12	230	5,0	1,15	1,04	198	3,8	0,91	0,91	157	2,5	0,75	0,75	129	1,7
	V MAX	280	1,26	1,04	217	4,5	1,08	0,97	186	3,4	0,85	0,85	146	2,2	0,70	0,70	120	1,5
	IV	245	1,14	0,93	196	3,7	0,98	0,87	169	2,9	0,76	0,76	131	1,8	0,63	0,63	108	1,3
	III	220	1,06	0,86	182	3,3	0,91	0,80	157	2,5	0,70	0,70	120	1,6	0,58	0,58	100	1,1
	II MED	180	0,89	0,71	153	2,4	0,77	0,66	132	1,9	0,59	0,59	101	1,1	0,48	0,48	83	0,8
	I MIN	140	0,74	0,58	127	1,8	0,64	0,54	110	1,4	0,48	0,48	83	0,8	0,40	0,40	69	0,6
SEC/OW 2.3-2T	VI	560	2,73	2,18	470	9,7	2,37	2,03	408	7,5	1,79	1,79	308	4,5	1,48	1,48	255	3,2
	V	470	2,38	1,88	409	7,7	2,07	1,75	356	5,9	1,54	1,54	265	3,5	1,27	1,27	218	2,5
	IV MAX	380	2,01	1,56	346	5,7	1,75	1,46	301	4,4	1,29	1,29	222	2,5	1,07	1,07	184	1,8
	III	305	1,68	1,29	289	4,1	1,46	1,20	251	3,2	1,06	1,06	182	1,8	0,88	0,88	151	1,3
	II MED	240	1,38	1,05	237	2,9	1,20	0,98	206	2,3	0,86	0,86	148	1,2	0,71	0,71	122	0,9
	I MIN	200	1,16	0,88	200	2,2	1,02	0,82	175	1,7	0,69	0,69	119	0,9	0,60	0,60	103	0,7
SEC/OW 3.3-2T	VI	680	3,44	2,71	592	17,0	2,99	2,53	514	13,2	2,22	2,22	382	7,7	1,84	1,84	316	5,5
	V	620	3,19	2,50	549	14,9	2,78	2,33	478	11,6	2,05	2,05	353	6,7	1,70	1,70	292	4,7
	IV MAX	540	2,84	2,21	488	12,2	2,48	2,06	427	9,5	1,81	1,81	311	5,4	1,50	1,50	258	3,8
	III MED	440	2,41	1,86	415	9,1	2,11	1,73	363	7,1	1,53	1,53	263	4,0	1,27	1,27	218	2,8
	II	360	2,02	1,54	347	6,7	1,77	1,43	304	5,2	1,26	1,26	217	2,9	1,05	1,05	181	2,0
	I MIN	290	1,68	1,27	289	4,8	1,47	1,18	253	3,8	1,01	1,00	174	1,9	0,86	0,86	148	1,4

Correction factors for different R.H.

U.R.	WT:	7/12°C	8/13°C	10/15°C	12/17°C
48%	Pc	0,95	0,94	1,00	1,00
	Ps	1,00	1,00	1,00	1,00
46%	Pc	0,90	0,88	1,00	1,00
	Ps	1,00	1,00	1,00	1,00

Legend

- WT** = Water temperature
- Pc** = Cooling Total emission
- Ps** = Cooling Sensible emission
- Qw** = Water flow
- Dp(c)** = Water side pressure drop
- Speed** = Fan speed
- MAX** = High speed
- MED** = Medium speed
- MIN** = Low speed
- Qv** = Air flow

Cooling emission of 4 row coil

Entering air temperature: +27°C - Relative Humidity: 50%

Model	Speed	WT: 7/12 °C					WT: 8/13 °C				WT: 10/15 °C				WT: 12/17 °C			
		Qv	Pc	Ps	Qw	Dp(c)	Pc	Ps	Qw	Dp(c)	Pc	Ps	Qw	Dp(c)	Pc	Ps	Qw	Dp(c)
		m³/h	kW	kW	l/h	kPa	kW	kW	l/h	kPa	kW	kW	l/h	kPa	kW	kW	l/h	kPa
SEC/OW 1.4-2T	VI	305	2,01	1,42	346	16,7	1,80	1,33	310	13,7	1,36	1,16	234	8,2	1,02	1,02	175	4,9
	V MAX	280	1,87	1,31	322	14,6	1,68	1,23	289	12,0	1,27	1,07	218	7,3	0,95	0,95	163	4,3
	IV	245	1,67	1,16	287	12,1	1,50	1,09	258	9,9	1,14	0,95	196	6,0	0,84	0,84	144	3,5
	III	220	1,54	1,07	265	10,5	1,39	1,00	239	8,6	1,06	0,87	182	5,3	0,77	0,77	132	3,0
	II MED	180	1,28	0,88	220	7,6	1,15	0,83	198	6,2	0,88	0,72	151	3,8	0,64	0,64	110	2,1
	I MIN	140	1,05	0,71	181	5,3	0,94	0,67	162	4,4	0,72	0,58	124	2,7	0,52	0,52	89	1,5
SEC/OW 2.4-2T	VI	560	3,85	2,66	662	24,7	3,47	2,50	597	20,4	2,65	2,18	456	12,6	1,93	1,93	332	7,0
	V	470	3,32	2,28	571	19,0	2,99	2,14	514	15,7	2,30	1,86	396	9,7	1,65	1,65	284	5,4
	IV MAX	380	2,76	1,88	475	13,7	2,49	1,77	428	11,4	1,92	1,54	330	7,1	1,36	1,36	234	3,8
	III	305	2,28	1,54	392	9,8	2,06	1,45	354	8,1	1,59	1,26	273	5,1	1,11	1,11	191	2,7
	II MED	240	1,84	1,24	316	6,8	1,67	1,17	287	5,6	1,29	1,01	222	3,5	0,85	0,85	146	1,7
	I MIN	200	1,54	1,04	265	4,9	1,40	0,97	241	4,1	1,09	0,85	187	2,6	0,72	0,72	124	1,2
SEC/OW 3.4-2T	VI	680	4,69	3,24	807	20,3	4,22	3,05	726	16,8	3,23	2,65	556	10,4	2,34	2,34	402	5,8
	V MAX	620	4,32	2,98	743	17,6	3,89	2,80	669	14,6	2,98	2,44	513	9,0	2,15	2,15	370	5,0
	IV MED	540	3,83	2,62	659	14,2	3,45	2,47	593	11,8	2,65	2,15	456	7,3	1,90	1,90	327	4,0
	III	440	3,22	2,19	554	10,5	2,91	2,06	501	8,7	2,24	1,79	385	5,4	1,59	1,59	273	2,9
	II MIN	360	2,67	1,81	459	7,5	2,41	1,70	415	6,3	1,86	1,48	320	3,9	1,30	1,30	224	2,1
	I	290	2,20	1,48	378	5,4	1,99	1,39	342	4,5	1,54	1,21	265	2,8	1,01	1,01	174	1,3

Entering air temperature: +26°C - Relative Humidity: 50%

Model	Speed	WT: 7/12 °C					WT: 8/13 °C				WT: 10/15 °C				WT: 12/17 °C			
		Qv	Pc	Ps	Qw	Dp(c)	Pc	Ps	Qw	Dp(c)	Pc	Ps	Qw	Dp(c)	Pc	Ps	Qw	Dp(c)
		m³/h	kW	kW	l/h	kPa	kW	kW	l/h	kPa	kW	kW	l/h	kPa	kW	kW	l/h	kPa
SEC/OW 1.4-2T	VI	305	1,79	1,33	308	13,6	1,58	1,25	272	10,9	1,14	1,07	196	6,0	0,94	0,94	162	4,2
	V MAX	280	1,67	1,23	287	12,0	1,47	1,15	253	9,6	1,06	0,99	182	5,3	0,87	0,87	150	3,7
	IV	245	1,49	1,10	256	9,9	1,32	1,03	227	7,9	0,96	0,88	165	4,4	0,77	0,77	132	3,0
	III	220	1,38	1,01	237	8,6	1,22	0,94	210	6,9	0,89	0,81	153	3,9	0,71	0,71	122	2,6
	II MED	180	1,15	0,83	198	6,2	1,02	0,78	175	5,0	0,74	0,67	127	2,8	0,58	0,58	100	1,8
	I MIN	140	0,94	0,67	162	4,3	0,83	0,63	143	3,5	0,61	0,54	105	2,0	0,47	0,47	81	1,3
SEC/OW 2.4-2T	VI	560	3,44	2,51	592	20,3	3,06	2,35	526	16,3	2,24	2,02	385	9,3	1,76	1,76	303	6,0
	V	470	2,97	2,15	511	15,6	2,64	2,01	454	12,6	1,94	1,73	334	7,2	1,51	1,51	260	4,6
	IV MAX	380	2,47	1,77	425	11,3	2,20	1,66	378	9,2	1,62	1,43	279	5,3	1,25	1,25	215	3,3
	III	305	2,04	1,45	351	8,1	1,82	1,36	313	6,6	1,35	1,17	232	3,8	1,02	1,02	175	2,3
	II MED	240	1,65	1,17	284	5,6	1,48	1,10	255	4,5	1,10	0,94	189	2,6	0,82	0,82	141	1,6
	I MIN	200	1,39	0,98	239	4,1	1,24	0,91	213	3,3	0,92	0,78	158	2,0	0,68	0,68	117	1,1
SEC/OW 3.4-2T	VI	680	4,19	3,06	721	16,7	3,72	2,86	640	13,5	2,72	2,46	468	7,7	2,15	2,15	370	5,0
	V MAX	620	3,87	2,81	666	14,5	3,43	2,63	590	11,7	2,52	2,26	433	6,7	1,97	1,97	339	4,3
	IV MED	540	3,43	2,47	590	11,7	3,05	2,31	525	9,5	2,24	1,99	385	5,4	1,74	1,74	299	3,5
	III	440	2,88	2,07	495	8,7	2,57	1,93	442	7,0	1,89	1,66	325	4,0	1,45	1,45	249	2,5
	II MIN	360	2,39	1,70	411	6,2	2,13	1,59	366	5,1	1,58	1,37	272	2,9	1,19	1,19	205	1,8
	I	290	1,97	1,40	339	4,4	1,76	1,31	303	3,6	1,31	1,12	225	2,1	0,98	0,98	169	1,3

Entering air temperature: +25°C - Relative Humidity: 50%

Model	Speed	WT: 7/12 °C					WT: 8/13 °C				WT: 10/15 °C				WT: 12/17 °C			
		Qv	Pc	Ps	Qw	Dp(c)	Pc	Ps	Qw	Dp(c)	Pc	Ps	Qw	Dp(c)	Pc	Ps	Qw	Dp(c)
		m³/h	kW	kW	l/h	kPa	kW	kW	l/h	kPa	kW	kW	l/h	kPa	kW	kW	l/h	kPa
SEC/OW 1.4-2T	VI	305	1,58	1,25	272	10,9	1,37	1,16	236	8,4	1,03	1,03	177	5,0	0,85	0,85	146	3,5
	V MAX	280	1,47	1,16	253	9,6	1,27	1,08	218	7,4	0,95	0,95	163	4,4	0,78	0,78	134	3,1
	IV	245	1,32	1,03	227	7,9	1,14	0,96	196	6,1	0,84	0,84	144	3,5	0,70	0,70	120	2,5
	III	220	1,22	0,94	210	6,9	1,06	0,88	182	5,4	0,78	0,78	134	3,1	0,64	0,64	110	2,2
	II MED	180	1,01	0,78	174	5,0	0,88	0,72	151	3,9	0,64	0,64	110	2,2	0,53	0,53	91	1,5
	I MIN	140	0,83	0,63	143	3,5	0,72	0,58	124	2,7	0,52	0,52	89	1,5	0,43	0,43	74	1,1
SEC/OW 2.4-2T	VI	560	3,05	2,36	525	16,4	2,66	2,19	458	12,8	1,93	1,93	332	7,2	1,60	1,60	275	5,1
	V	470	2,63	2,02	452	12,6	2,30	1,88	396	9,9	1,65	1,65	284	5,5	1,37	1,37	236	3,9
	IV MAX	380	2,19	1,66	377	9,2	1,92	1,55	330	7,2	1,31	1,31	225	3,6	1,14	1,14	196	2,8
	III	305	1,81	1,36	311	6,6	1,59	1,27	273	5,2	1,09	1,07	187	2,6	0,93	0,93	160	2,0
	II MED	240	1,47	1,10	253	4,5	1,29	1,02	222	3,6	0,90	0,86	155	1,9	0,75	0,75	129	1,3
	I MIN	200	1,23	0,92	212	3,3	1,08	0,85	186	2,6	0,76	0,72	131	1,4	0,62	0,62	107	1,0
SEC/OW 3.4-2T	VI	680	3,71	2,87	638	13,5	3,24	2,67	557	10,5	2,35	2,35	404	5,9	1,95	1,95	335	4,2
	V MAX	620	3,42	2,63	588	11,7	2,99	2,45	514	9,2	2,16	2,16	372	5,1	1,79	1,79	308	3,6
	IV MED	540	3,03	2,32	521	9,5	2,65	2,16	456	7,4	1,91	1,91	329	4,1	1,58	1,58	272	2,9
	III	440	2,56	1,94	440	7,0	2,24	1,80	385	5,5	1,53	1,52	263	2,8	1,32	1,32	227	2,1
	II MIN	360	2,12	1,60	365	5,0	1,86	1,49	320	4,0	1,28	1,25	220	2,0	1,09	1,09	187	1,5
	I	290	1,75	1,31	301	3,6	1,54	1,22	265	2,8	1,07	1,03	184	1,5	0,89	0,89	153	1,1

Correction factors for different R.H.

U.R.	WT:	7/12°C	8/13°C	10/15°C	12/17°C
48%	Pc	0,95	0,94	1,00	1,00
	Ps	1,00	1,00	1,00	1,00
46%	Pc	0,90	0,88	1,00	1,00
	Ps	1,00	1,00	1,00	1,00

Legend

- WT = Water temperature
- Pc = Cooling Total emission
- Ps = Cooling Sensible emission
- Qw = Water flow
- Dp(c) = Water side pressure drop
- Speed = Fan speed
- MAX = High speed
- MED = Medium speed
- MIN = Low speed
- Qv = Air flow

Heating emission of 3 row coil

Entering air temperature: +20°C

Model	Speed	WT: 70/60°C				WT: 60/50°C			WT: 50/40°			WT: 50/45°			WT: 45/40°		
		Qv m³/h	Ph kW	Qw l/h	Dp(c) kPa	Ph kW	Qw l/h	Dp(c) kPa	Ph kW	Qw l/h	Dp(c) kPa	Ph kW	Qw l/h	Dp(c) kPa	Ph kW	Qw l/h	Dp(c) kPa
SEC/OW 1.3-2T	VI	305	3,54	304	6,3	2,71	233	4,1	1,87	161	2,2	2,16	372	9,5	1,75	301	6,7
	V MAX	280	3,29	283	5,6	2,51	216	3,6	1,74	150	1,9	2,01	346	8,4	1,62	279	5,9
	IV	245	2,94	253	4,6	2,25	194	2,9	1,56	134	1,6	1,80	310	6,9	1,45	249	4,8
	III	220	2,71	233	4,0	2,07	178	2,5	1,44	124	1,4	1,66	286	6,0	1,34	230	4,2
	I MIN	140	1,84	158	2,0	1,41	121	1,3	0,98	84	0,7	1,12	193	3,0	0,91	157	2,1
SEC/OW 2.3-2T	VI	560	6,64	571	10,7	5,10	439	6,9	3,55	305	3,8	4,06	698	16,1	3,29	566	11,3
	V	470	5,77	496	8,3	4,43	381	5,4	3,09	266	3,0	3,52	605	12,5	2,86	492	8,8
	IV MAX	380	4,79	412	6,0	3,68	316	3,9	2,57	221	2,1	2,93	504	9,0	2,38	409	6,4
	III	305	3,95	340	4,3	3,03	261	2,8	2,12	182	1,5	2,41	415	6,4	1,96	337	4,5
	I MIN	200	2,68	230	2,2	2,07	178	1,4	1,45	125	0,8	1,64	282	3,3	1,33	229	2,3
SEC/OW 3.3-2T	VI	680	8,20	705	18,0	6,30	542	11,7	4,40	378	6,4	5,01	862	27,1	4,07	700	19,1
	V	620	7,61	654	15,8	5,85	503	10,3	4,09	352	5,6	4,65	800	23,8	3,77	648	16,8
	IV MAX	540	6,73	579	12,7	5,18	445	8,3	3,62	311	4,6	4,11	707	19,2	3,34	574	13,5
	III MED	440	5,65	486	9,4	4,35	374	6,1	3,04	261	3,4	3,45	593	14,1	2,80	482	9,9
	I MIN	290	3,85	331	4,8	2,96	255	3,1	2,08	179	1,7	2,35	404	7,2	1,91	329	5,1

Heating emission of 4 row coil

Entering air temperature: +20°C

Model	Speed	WT: 70/60°C				WT: 60/50°C			WT: 50/40°			WT: 50/45°			WT: 45/40°		
		Qv m³/h	Ph kW	Qw l/h	Dp(c) kPa	Ph kW	Qw l/h	Dp(c) kPa	Ph kW	Qw l/h	Dp(c) kPa	Ph kW	Qw l/h	Dp(c) kPa	Ph kW	Qw l/h	Dp(c) kPa
SEC/OW 1.4-2T	VI	305	3,80	327	11,7	2,92	251	7,6	2,03	175	4,2	2,32	399	17,7	1,88	323	12,4
	V MAX	280	3,52	303	10,2	2,70	232	6,6	1,88	162	3,6	2,15	370	15,4	1,74	299	10,8
	IV	245	3,14	270	8,4	2,42	208	5,5	1,69	145	3,0	1,92	330	12,7	1,56	268	8,9
	III	220	2,89	249	7,2	2,22	191	4,7	1,55	133	2,6	1,77	304	10,9	1,43	246	7,7
	I MIN	140	1,92	165	3,5	1,48	127	2,3	1,03	89	1,3	1,17	201	5,3	0,95	163	3,7
SEC/OW 2.4-2T	VI	560	7,46	642	18,2	5,75	495	11,8	4,04	347	6,6	4,56	784	27,3	3,71	638	19,4
	V	470	6,37	548	13,8	4,92	423	9,0	3,46	298	5,0	3,90	671	20,7	3,17	545	14,7
	IV MAX	380	5,22	449	9,7	4,03	347	6,3	2,84	244	3,5	3,19	549	14,6	2,60	447	10,4
	III	305	4,25	366	6,7	3,28	282	4,4	2,31	199	2,5	2,60	447	10,1	2,12	365	7,2
	I MIN	200	2,82	243	3,3	2,18	187	2,2	1,54	132	1,2	1,73	298	4,9	1,41	243	3,5
SEC/OW 3.4-2T	VI	680	8,72	750	13,9	6,71	577	9,1	4,70	404	5,0	5,33	917	20,9	4,33	745	14,8
	V MAX	620	8,00	688	12,0	6,16	530	7,8	4,31	371	4,3	4,89	841	18,0	3,97	683	12,7
	IV MED	540	7,04	605	9,6	5,42	466	6,2	3,80	327	3,4	4,30	740	14,4	3,40	585	10,2
	III	440	5,87	505	6,9	4,52	389	4,5	3,18	273	2,5	3,59	617	10,4	2,92	502	7,4
	I MIN	290	3,96	341	3,5	3,06	263	2,3	2,15	185	1,3	2,42	416	5,2	1,97	339	3,7

Legend

- WT = Water temperature
- Ph = Emission
- Qw = Water flow
- Dp(c) = Water side pressure drop
- Speed = Fan speed
- MAX = High speed
- MED = Medium speed
- MIN = Low speed
- Qv = Air flow

Heating emission of 1 row additional coil

Entering air temperature: +20°C

		WT: 80/70°C				WT: 75/65°			WT: 70/60°			WT: 65/55°			WT: 60/50°			WT: 55/45°		
Model	Speed	Qv	Ph	Qw	Dp(c)	Ph	Qw	Dp(c)	Ph	Qw	Dp(c)	Ph	Qw	Dp(c)	Ph	Qw	Dp(c)	Ph	Qw	Dp(c)
		m³/h	kW	l/h	kPa	kW	l/h	kPa	kW	l/h	kPa	kW	l/h	kPa	kW	l/h	kPa	kW	l/h	kPa
SEC/OW 1.3-4T	VI	305	1,95	168	5,8	1,75	151	4,9	1,56	134	4,0	1,36	117	3,2	1,17	101	2,5	0,97	83	1,8
	V MAX	280	1,83	157	5,2	1,65	142	4,4	1,47	126	3,6	1,28	110	2,9	1,10	95	2,2	0,92	79	1,6
	IV	245	1,67	144	4,4	1,51	130	3,7	1,34	115	3,1	1,17	101	2,5	1,00	86	1,9	0,84	72	1,4
	III	220	1,57	135	3,9	1,41	121	3,3	1,25	108	2,7	1,10	95	2,2	0,94	81	1,7	0,78	67	1,3
	I MIN	140	1,15	99	2,3	1,03	89	1,9	0,92	79	1,6	0,81	70	1,3	0,69	59	1,0	0,58	50	0,7
SEC/OW 2.3-4T	VI	560	3,84	330	4,7	3,46	298	3,9	3,07	264	3,2	2,37	204	1,0	2,31	199	2,0	1,93	166	1,5
	V	470	3,41	293	3,8	3,07	264	3,2	2,73	235	2,6	2,10	181	0,8	2,05	176	1,6	1,71	147	1,2
	IV MAX	380	2,94	253	2,9	2,65	228	2,5	2,35	202	2,0	1,82	157	0,6	1,77	152	1,3	1,48	127	0,9
	III	305	2,52	217	2,2	2,27	195	1,9	2,02	174	1,6	1,57	135	0,5	1,52	131	1,0	1,27	109	0,7
	I MIN	200	1,86	160	1,3	1,68	144	1,1	1,49	128	0,9	1,16	100	0,3	1,13	97	0,6	0,94	81	0,4
SEC/OW 3.3-4T	VI	680	4,84	416	8,2	4,36	375	7,0	3,89	335	5,8	3,41	293	4,7	2,94	253	3,6	2,46	212	2,7
	V	620	4,53	390	7,3	4,08	351	6,2	3,64	313	5,1	3,19	274	4,1	2,75	237	3,2	2,31	199	2,4
	IV MAX	540	4,10	353	6,2	3,70	318	5,2	3,30	284	4,3	2,89	249	3,5	2,49	214	2,7	2,09	180	2,0
	III MED	440	3,57	307	4,8	3,22	277	4,1	2,87	247	3,4	2,52	217	2,7	2,17	187	2,1	1,82	157	1,6
	I MIN	290	2,64	227	2,8	2,38	205	2,4	2,12	182	2,0	1,86	160	1,6	1,61	138	1,3	1,35	116	0,9
SEC/OW 3.4-4T	VI	680	4,84	416	8,2	4,36	375	7,0	3,89	335	5,8	3,41	293	4,7	2,94	253	3,6	2,46	212	2,7
	V MAX	620	4,53	390	7,3	4,08	351	6,2	3,64	313	5,1	3,19	274	4,1	2,75	237	3,2	2,31	199	2,4
	IV MED	540	4,10	353	6,2	3,70	318	5,2	3,30	284	4,3	2,89	249	3,5	2,49	214	2,7	2,09	180	2,0
	III	440	3,57	307	4,8	3,22	277	4,1	2,87	247	3,4	2,52	217	2,7	2,17	187	2,1	1,82	157	1,6
	I MIN	290	2,64	227	2,8	2,38	205	2,4	2,12	182	2,0	1,86	160	1,6	1,61	138	1,3	1,35	116	0,9

Heating emission of 2 row additional coil

Entering air temperature: +20°C

		WT: 65/55°C				WT: 60/50°			WT: 55/45°			WT: 50/40°			WT: 45/40°			WT: 45/35°		
Model	Speed	Qv	Ph	Qw	Dp(c)	Ph	Qw	Dp(c)	Ph	Qw	Dp(c)	Ph	Qw	Dp(c)	Ph	Qw	Dp(c)	Ph	Qw	Dp(c)
		m³/h	kW	l/h	kPa	kW	l/h	kPa	kW	l/h	kPa	kW	l/h	kPa	kW	l/h	kPa	kW	l/h	kPa
SEC/OW 1.3-4T/ 2R	VI	305	2,38	205	15,5	2,05	176	12,2	1,73	149	9,2	1,41	121	6,5	1,33	229	20,0	1,09	94	4,2
	V MAX	280	2,23	192	13,8	1,92	165	10,8	1,62	139	8,2	1,32	114	5,8	1,25	215	17,8	1,02	88	3,7
	IV	245	2,02	174	11,6	1,75	151	9,1	1,47	126	6,9	1,20	103	4,9	1,13	194	15,0	0,92	79	3,1
	III	220	1,88	162	10,3	1,63	140	8,1	1,37	118	6,1	1,12	96	4,3	1,05	181	13,3	0,86	74	2,8
	I MIN	140	1,35	116	5,7	1,16	100	4,5	0,98	84	3,4	0,80	69	2,4	0,75	129	7,4	0,62	53	1,6
SEC/OW 2.3-4T/ 2R	VI	560	4,66	401	12,7	4,03	347	10,0	3,40	292	7,6	2,78	239	5,4	2,61	449	16,5	2,15	185	3,5
	V	470	4,08	351	10,1	3,53	304	8,0	2,99	257	6,0	2,44	210	4,3	2,29	394	13,1	1,89	163	2,8
	IV MAX	380	3,47	298	7,6	3,00	258	6,0	2,54	218	4,5	2,09	180	3,3	1,96	337	10,0	1,62	139	2,1
	III	305	2,95	254	5,7	2,55	219	4,5	2,16	186	3,4	1,77	152	2,4	1,65	284	7,4	1,37	118	1,6
	I MIN	200	2,43	209	4,1	2,11	181	3,2	1,78	153	2,4	1,46	126	1,7	1,36	234	5,3	1,14	98	1,1
SEC/OW 3.3-4T/ 2R	VI	680	5,83	501	22,5	5,06	435	17,8	4,28	368	13,5	3,50	301	9,6	3,27	562	29,1	2,73	235	6,3
	V	620	5,42	466	19,8	4,70	404	15,6	3,98	342	11,8	3,26	280	8,5	3,04	523	25,6	2,54	218	5,6
	IV MAX	540	4,86	418	16,3	4,22	363	12,9	3,57	307	9,8	2,92	251	7,0	2,72	468	21,1	2,28	196	4,6
	III MED	440	4,20	361	12,6	3,65	314	10,0	3,09	266	7,6	2,53	218	5,4	2,36	406	16,4	1,98	170	3,6
	I MIN	290	2,96	255	6,8	2,57	221	5,4	2,18	187	4,1	1,79	154	3,0	1,66	286	8,8	1,40	120	1,9

Legend

- WT** = Water temperature
- Ph** = Emission
- Qw** = Water flow
- Dp(c)** = Water side pressure drop
- Speed** = Fan speed
- MAX** = High speed
- MED** = Medium speed
- MIN** = Low speed
- Qv** = Air flow

3 row coil

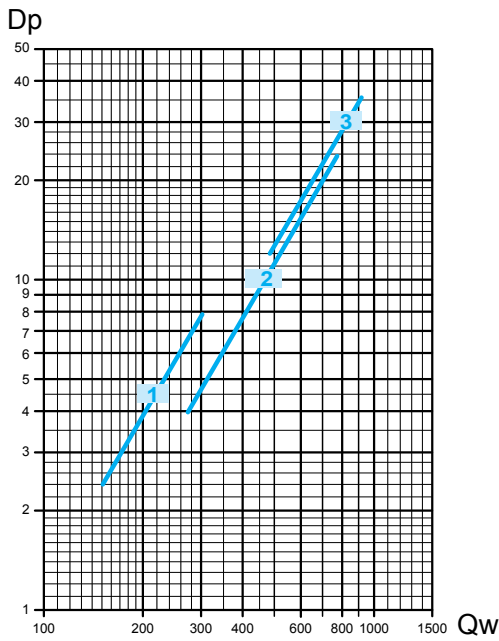

4 row coil

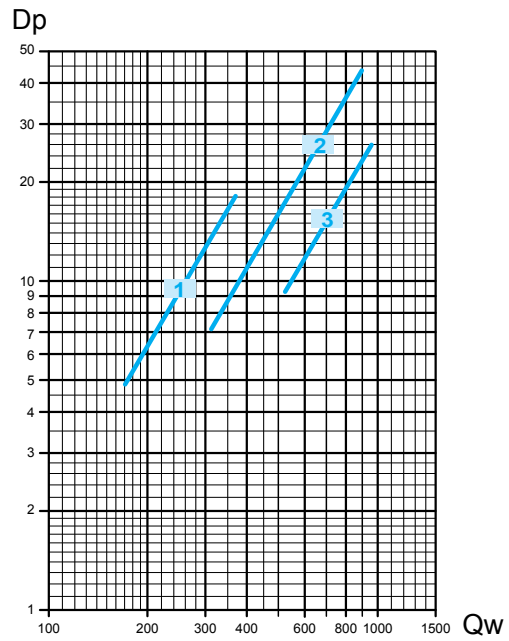

Pressure drop for mean water temperature of 10°C; for different temperatures multiply the pressure drop figure by the K correction factors in the table.

°C	20	30	40	50	60	70	80
K	0,94	0,90	0,86	0,82	0,78	0,74	0,70

1 row additional coil

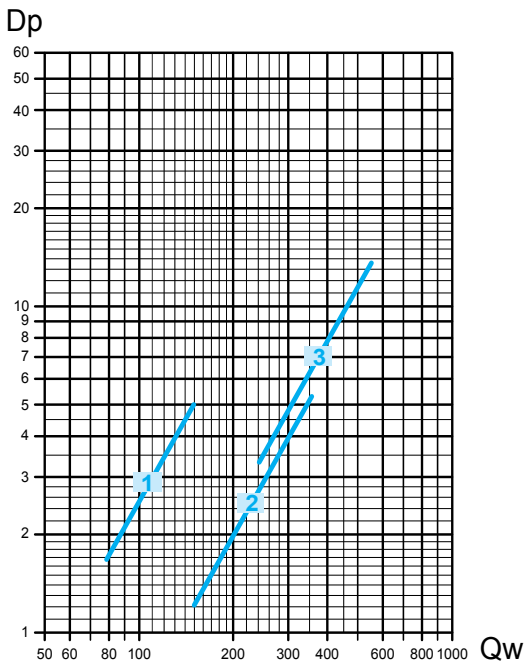

2 row additional coil

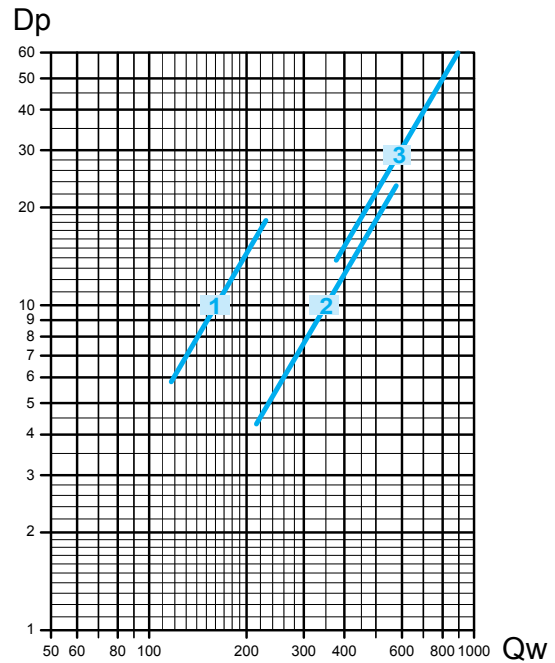

Pressure drop for mean water temperature of 65°C; for different temperatures multiply the pressure drop figure by the K correction factors in the table.

°C	40	50	60	70	80
K	1,14	1,08	1,02	0,96	0,90

Legend

Qw = water flow (l/h)

Dp = pressure drop (kPa)

VBP Main coil 3 way valve

Control valve kit: 3 way valve, ON-OFF, with electric motor and mounting kit with micrometric lockshield valve.

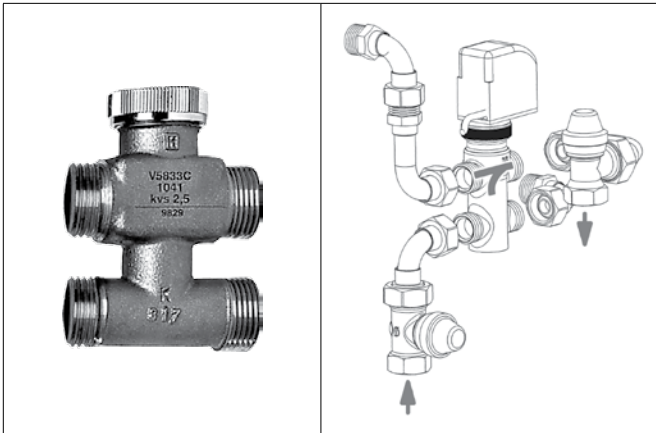

VBA Additional coil 3 way valve

Control valve kit: 3 way valve, ON-OFF, with electric motor and mounting kit with micrometric lockshield valve.

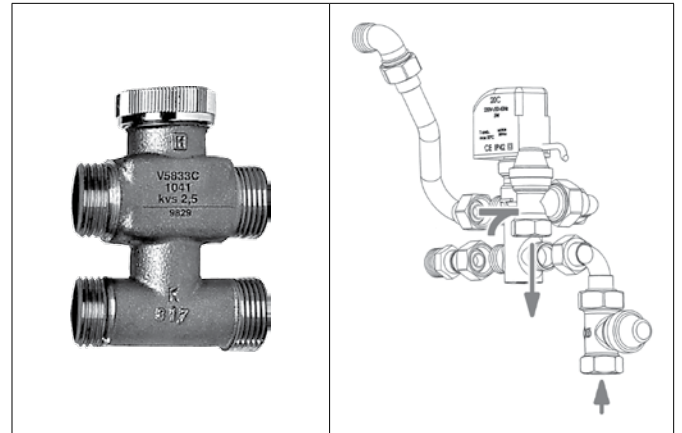

VS Simplified kit for 3 way valve for main and additional coil

3 way valve, (ON-OFF) with electric motor and mounting kit. Valve with flat connection without micrometric lockshield valve.

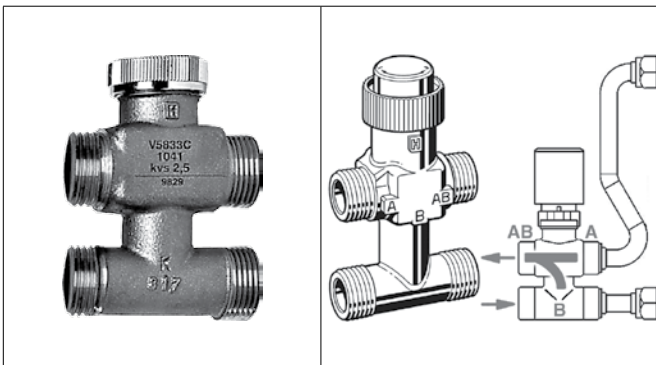

V2 2 way valve for main and additional coil

Control valve kit: 2 way valve, ON-OFF, with electric motor and mounting kit.

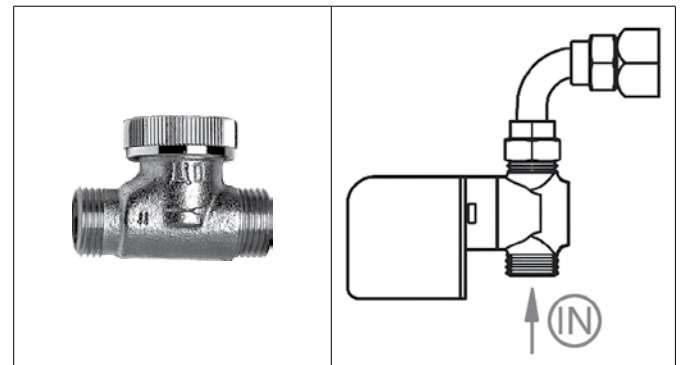

Valve	type	mod.	Valve			Micrometric lockshield valve			Code		Valves pressure drop
			DN	(Ø)	Kvs	DN	(Ø)	Kvs	Fitted	Not Fitted	
VBP	Main	1 - 2	15	1/2"	1,6	15	1/2"	2	9066561H	9066560H	
	Main	3	20	3/4"	2,5	15	1/2"	2	9060471H	9060474H	
VBA	Additional	All	15	1/2"	1,6	15	1/2"	2	9060472H	9060475H	
VS	Main	1 - 2	15	1/2"	1,6	-	-	-	9066571H	9066570H	
		3	20	3/4"	2,5	-	-	-	9060484H	9060481H	
	Additional	All	15	1/2"	1,6	-	-	-	9060483H	9060480H	
V2	Main	1 - 2	15	1/2"	1,7	-	-	-	9060476H	9060478H	
		3	20	3/4"	2,8	-	-	-	9060477H	9060479H	
	Additional	All	15	1/2"	1,7	-	-	-	9060476H	9060478H	

Legend
Qw = water flow (l/h)
Dp = pressure drop (kPa)

3 way double valve kit for 4 tube installation and single coil

The kit consists of

- 2 special 3 way valves
- 2 230 Volt ON-OFF actuators with internal safety micro switch
- insulated pipe kit
- external valve insulation sleeve.

(\varnothing)	Kvs	Fitted		Not fitted	
		Code	ID	Code	ID
3/4"	2,2	9066572W	V3M4X2	9066562W	V3S4X2

The kit uses a special 3 way valve which allows the transformation of the fan coil, equipped with one single coil, into a 4 tube installation.

The new 4X2 valve has been designed to keep the water flow between flow and return perfectly separated, allowing its use in parallel. Therefore, it can be used on 4 pipe fan coil systems with one single heat-exchange coil on board the fan coil.

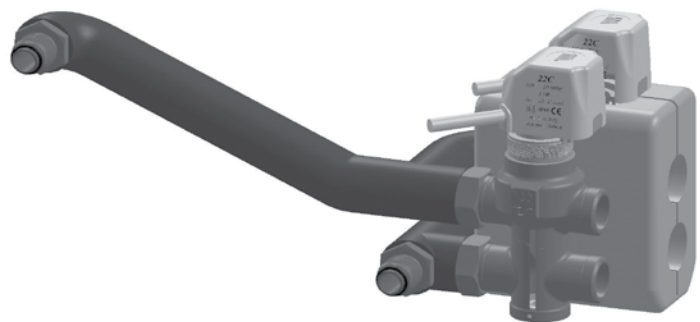
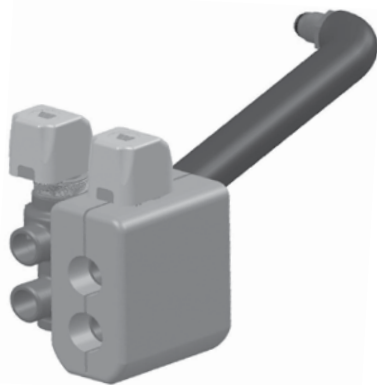
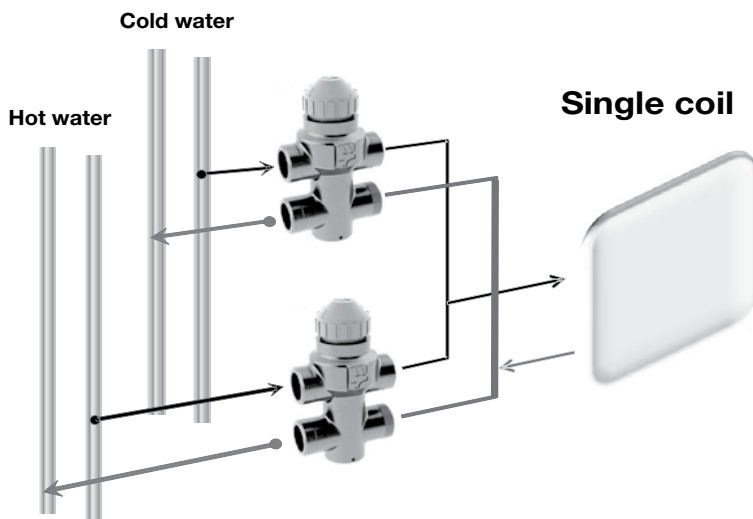
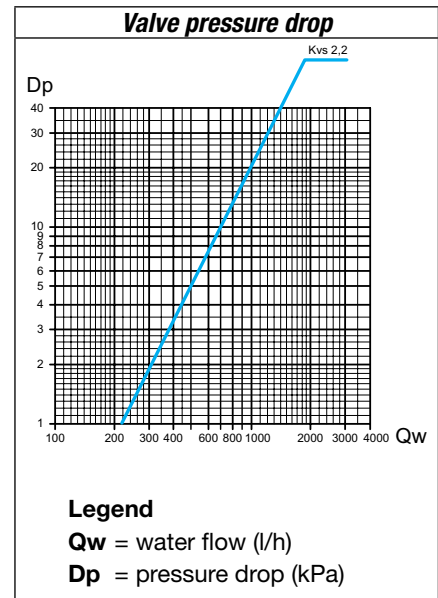

Double actuator electrical connections

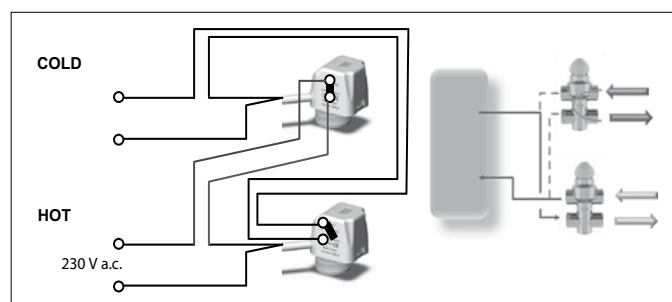
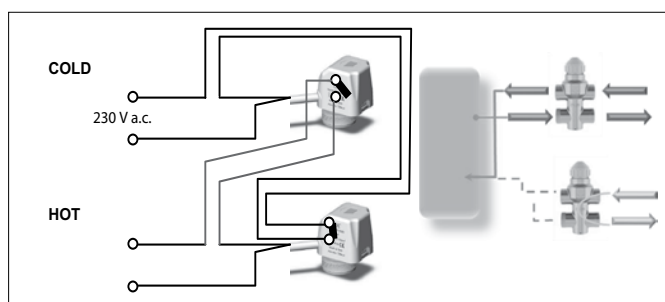

Balancing valves independent from the system pressure

- The balancing valve and a combined 2 way valve allow the regulation of the water flow value autonomously, regardless of the system pressure, and the control of the flow by using an On/Off electro-thermal actuator.
- The balancing valve allows you to balance the hydraulic system by supplying the required water flow, for each fan-coil, and to maintain it even under partial load conditions.
- A graduated ring nut placed under the valve allows you to set the flow rate value and also allows direct reading of the set value.



Valve operation logic

- “p1” is the valve inlet pressure
- “p3” is the outlet pressure
- “p2” is the diaphragm activation pressure, which allows differential pressure “p2” – “p3” to be maintained at a constant value, in order to guarantee the water to flow at the set value.

The minimum differential pressure “p1” - ”p3”, required to guarantee the correct value of the set water flow rate, is indicated in the diagrams on page 16. This is an essential factor to size the system pressure drop and pump pressure head.

The flow rate is kept at a constant value only if the valve pressure drop is higher than the indicated value.

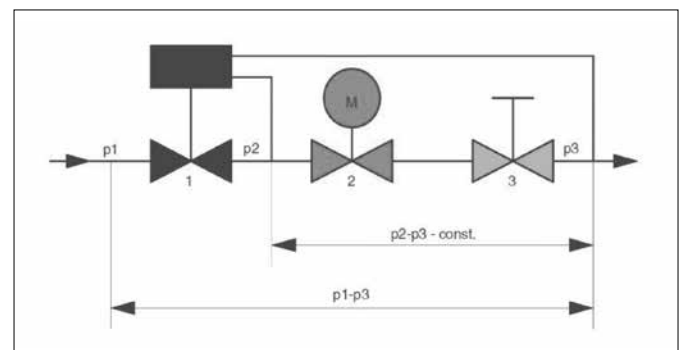

Minimum operating differential pressure

The minimum differential pressure and the balancing valve pressure drop must be considered to size the system pumps. Flow rate is constant if the pressure drop is higher than that indicated in the diagrams on page 16.

The following diagram shows an example of the flow rate trend according to the pressure drop and calibration required.

Example DN 10 model

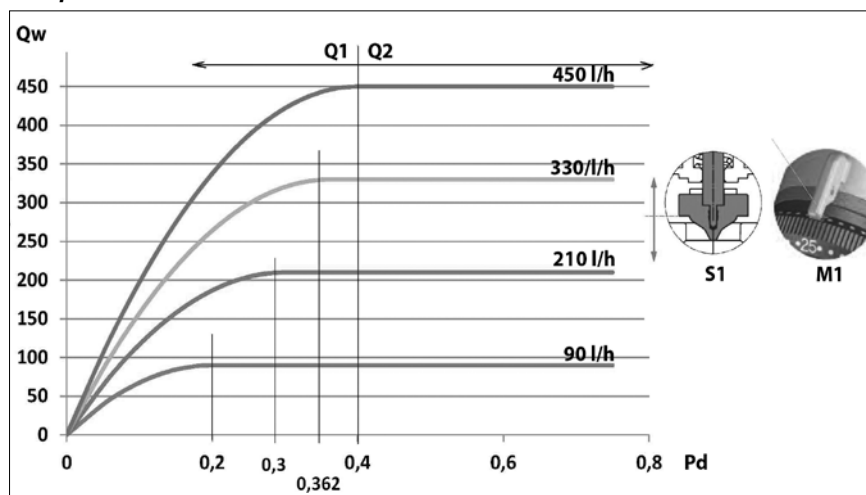

Legend

- Qw** = water flow rate
- Pd** = min. differential pressure “p1”-”p3” (bar)
- Q1** = area with inconstant water flow
- Q2** = area with constant water flow
- S1** = position of the adjustment valve plunger
- M1** = position of the knob

The valve upstream-downstream minimum differential pressure (“p1” –“p3”), which depends on the valve calibration value, must be exceeded to access the constant flow rate field.

DN 10 Model

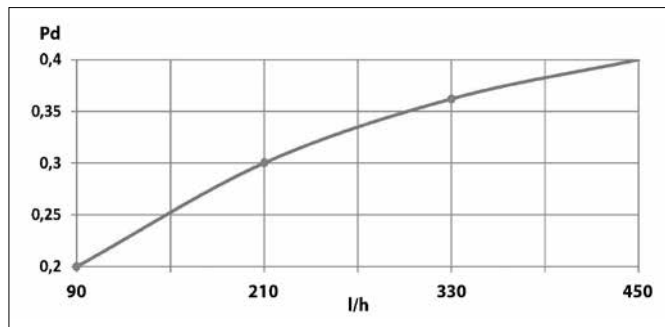

DN 15 Model

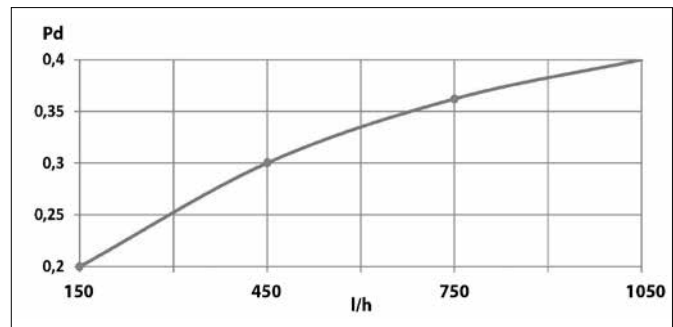

Legend

Pd = min. differential pressure “p1”-“p3” (bar)

E.g., when sizing the system pump, in which the DN 10 valves will be installed and in which 210 l/h are constantly required for each device, consider a useful pressure of 0.3 bar (to compensate the pressure drop of the valve) for each balancing valve. Therefore, the pressure drop values produced by the system balancing valves must be summed and the pump must be sized to produce a pressure equal to or greater than the value obtained previously.

Benefits

- Reduced dimensions
- Easy installation on 2 or 4 pipe devices
- Pre-regulation of the nominal value set even with installed actuator
- Easy display of the nominal value set. Nominal values are indicated in 10 l/h without any conversion
- Guarantee of constant flow rate set even with partial loads
- Pre-regulation can be blocked and leaded with the locking ring.

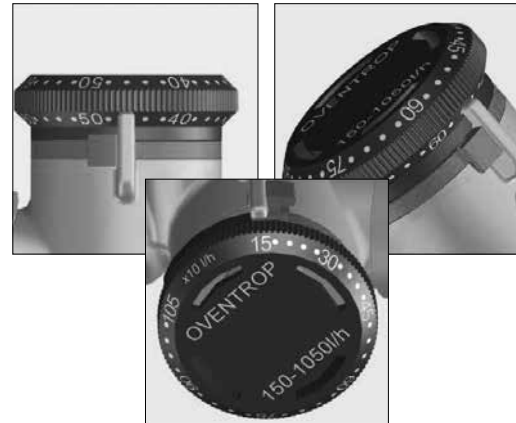

Technical features

DN Model	Flow Rate Range l/h	Kvs
DN 10	90 - 450	1,1
DN 15	150 - 1050	1,8

Operation limits of the balancing valves

- Maximum operating temperature 120°C
- Minimum operating temperature -10°C
- Maximum operating pressure 16 bar
- Maximum differential pressure 4 bar
- Maximum % of water/glycol mixture 50%

Balancing valves for main coil

2 way valve for main coil and assembly kit.

The valve is supplied equipped with 230 Volt electro-thermal actuator for the On/Off control.

mod.	Valve			Fitted		Not fitted	
	DN	Valve (Ø)	Range	Code	ID	Code	ID
1	10	1/2"	90-450	9066660	V20VBPM 90-450	9066650	V20VBPS 90-450
2 - 3	15	3/4"	150-1050	9066661	V20VBPM 150-1050	9066651	V20VBPS 150-1050

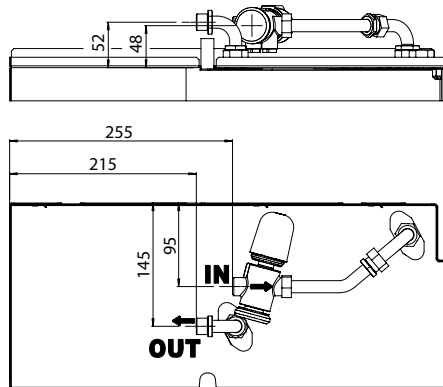

Balancing valves for additional coil

2 way valve for additional coil and assembly kit.

The valve is supplied equipped with 230 Volt electro-thermal actuator for the On control.

mod.	Valve			Fitted		Not fitted	
	DN	Valve (Ø)	Range	Code	ID	Code	ID
1 - 2 - 3	10	1/2"	90-450	9066663	V20VBPAM 90-450	9066653	V20VBPAS 90-450

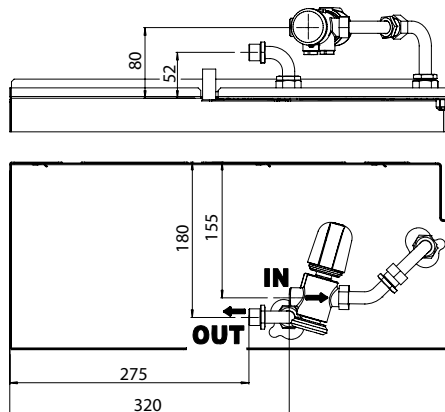

2 pipe system

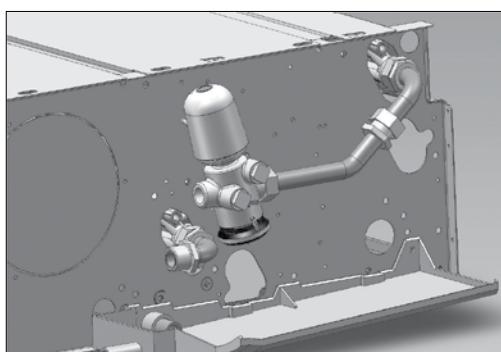

4 pipe system

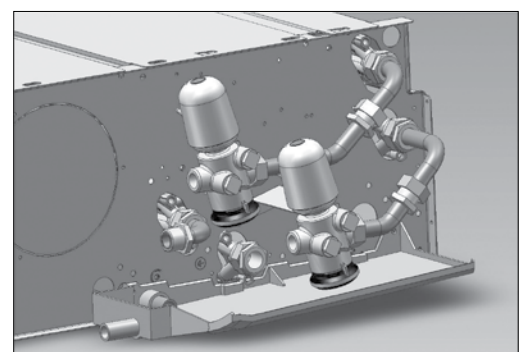

BEL Electric heater

1 PHASE 230V

Electric heater with integral: safety thermostat and relay control.

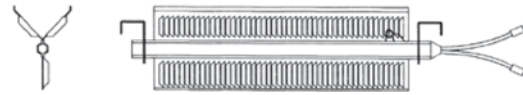

ID	BEL					
	1		2		3	
Size						
Watt	350	550	700	1150	900	1400
Code	9064051	9064031	9064052	9064032	9064053	9064033

BSO Extension condensate collection tray to cover valve assembly

Connection side	BSO	
	left	right
ID	BSO-SX	BSO-DX
Code	6060402	6060403

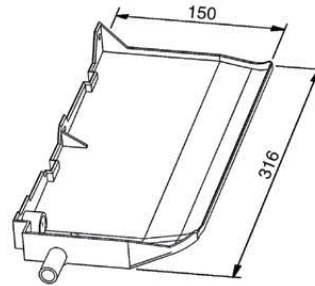

SCR plastic condensate drain pipe with fast connection

It helps regular drainage of condensate thereby preventing the formation of bends.

ID	SCR
Code	6060420

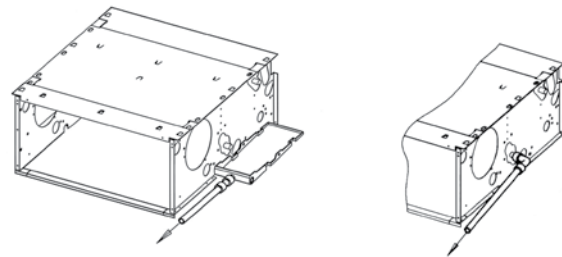

PCC condensate drain pump

ID	Fitted	Not fitted
	PCC-M	PCC-S
Code	9064011	9064010

Height for vertical flow (m)	Water flow (l/h) depending on the length of horizontal flow	
	5 m	10 m
1	6,8	6,3
2	5,5	5,0
3	4,2	3,8
4	3,0	2,6

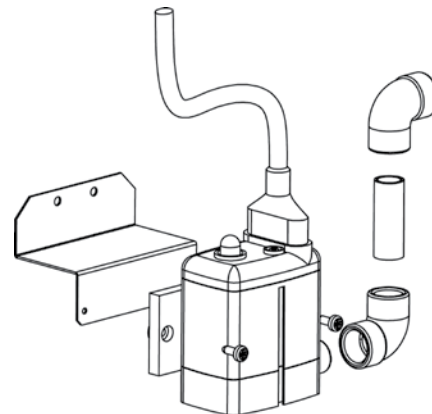

FRC fresh air connection

ID	FRC 100
Code	6064191

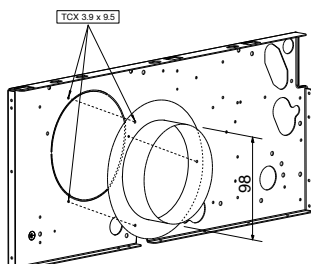

ID	FRC 120
Code	6064192

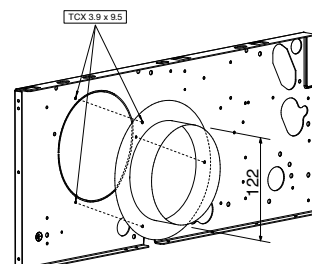

Electrical diagrams are shown on the installation, use and maintenance manual

T2T	●		●		●			●	●		●					9060174
TMO-503-SV2	●		●	●	●		●	●	●	●	●	●		○		9060172
T-MB (+UP-AU)	●	●	●	●	●	●	●	●	●	●	●	●	●		●	9066331E
WM-AU (+UP-AU)	●	●	●	●	●	●	●	●	●	●	●	●	●		●	9066632E
WM-TQR	●	●	●		●	●		●	●	●	●	●	●		●	9066631E
WM-T	●		●		●			●	●	●	●	●		●		9066630E
WM-3V	●		●													9066642

CONTROL IDENTIFICATION	CONTROL OPERATIONS
	ON-OFF switch
	ON-OFF switch for electric heater
	Manual 3 speed switch
	Manual/Automatic 3 speed selection
	Summer/Winter switch
	Remote centralized Summer/Winter switch or by an automatic change-over fitted on the water pipe
	Automatic Summer/Winter switch with neutral zone for 4 pipe installation with 2 valves
	Room thermostat for fan control (ON-OFF)
	Room thermostat for 1 valve control (2 pipe installation)
	Room thermostat for 2 valve control (4 pipe installation)
	Simultaneous thermostatic control of the valves and fan
	Room thermostat for chilled water valve (SUMMER) and electric heater (WINTER) control (in winter only the electric heater is working)
	Room thermostat for fan and electric heater control
	Installation of bimetallic low temperature CUT-OUT thermostat (TMM)
	Installation of electronic low temperature CUT-OUT thermostat (NTC)
	CONTROL CODES

ID	Code
WM-3V	9066642



Dimensions: 75x75x30 mm

- Manual 3 speed switch.
- Without thermostatic control.
- It can not control the valves.

ID	Code
WM-T	9066630E



Dimensions: 135x86x31 mm

- ON-OFF switch.
- Manual 3 speed switch.
- Manual Summer/Winter switch.
- Electronic room thermostat for fan control (ON-OFF).
- Electronic room thermostat for valve control (ON-OFF) (the fan keeps working).
- It allows to control the low temperature cut-out thermostat (TMM).
- It allows to control the chilled water valve (ON-OFF) and the electric heater (BEL) only in case that hot water is not used in winter (otherwise please use WM-TQR control with on/off switch for the electric heater).

ID	Code
WM-TQR	9066631E



Dimensions: 135x86x31 mm

- ON-OFF switch.
- Manual 3 speed switch.
- Manual, automatic or centralized Summer/Winter switch.
- Electric heater activation button.
- Electronic room thermostat for fan control (ON-OFF).
- Electronic room thermostat for valve control (ON-OFF).
- Simultaneous thermostatic control of the valves and fan.
- It allows to control the low temperature cut-out thermostat (NTC).
- It allows to control the water valves (ON-OFF) and the electric heater managed as main heating element or as an integration element.
- Energy saving function.

ID	Code
WM-AU	9066632E

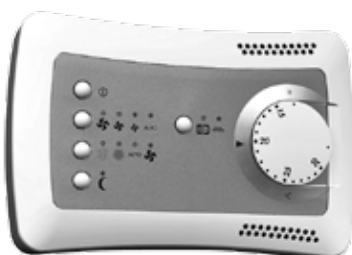

Dimensions: 135x86x24 mm

The control must always be connected with UPM-AU power unit (fitted on the unit) or with UP-AU power unit (not fitted on the unit).

- ON-OFF push button.
- Manual or automatic 3 speed progressive push button.
- Manual, automatic or centralized Summer/Winter switch.
- Summer/Winter/Fan/Auto mode push button.
- Electric heater activation button.
- Electronic room thermostat for fan control (ON-OFF).
- Electronic room thermostat for valve control (ON-OFF).
- Simultaneous thermostatic control of the valves and fan.
- It allows to control the low temperature cut-out thermostat (NTC).
- It allows to control the water valves (ON-OFF) and the electric heater managed as main heating element or as an integration element.
- Energy saving push button.

N.B.: with 4 pipe installations and continuous chilled and hot water supply, it allows the automatic summer winter change-over in accordance to the room temperature (-1°C = Winter, +1°C = Summer, Neutral Zone 2°C).

ID	Code
T-MB	9066331E



Dimensions: 110x72x25 mm

The control must always be connected with UPM-AU power unit (fitted on the unit) or with UP-AU power unit (not fitted on the unit).

Wall control with display that allows controlling one or more units in Master/Slave mode.

The control is equipped with internal sensor to detect the room temperature, which can be defined as a priority compared to the return air sensor on the fan coil.

The T-MB control features the following functions:

- Switch the unit ON and OFF.
- Temperature set.
- Manual, centralized or automatic Summer/Winter switch.
- Set the fan speed (low, medium, high or autofan).
- Set the operation mode (fan only, cooling, heating; auto for 4 pipe systems with mode selection depending on the air temperature.)
- It allows to control the water valves (ON-OFF) and the electric heater managed as main heating element or as an integration element.
- Time setting.
- Weekly ON/OFF program.

ID	Code
TMO-503-SV2	9060172



Dimensions: 118x87x8 mm

The TMO-503-SV2 control for fan coils with valves, is designed to be installed in a 503 wall box. The control is supplied integral with the external frame, but it is possible to use frames of the most known brand on the market (BTicino, Vimar, AVE, Gewiss).

- Manual or automatic speed switch.
- Manual Summer/Winter switch.
- Electronic thermostat for valve(s) control (ON-OFF).
- Simultaneous thermostatic control on the valves and fan (ON-OFF).
- It allows to control the low temperature cut-out thermostat (included with the control).

N.B.: with 4 pipe installations and continuous chilled and hot water supply, it allows the automatic summer winter change-over in accordance to the room temperature (-1°C = Winter, +1°C = Summer, Neutral Zone 2°C).

ID	Code
T2T	9060174



Dimensions: 128x75x25 mm

2 pipes units only

- ON-OFF switch.
- 3 speed switch.
- Manual Summer/Winter switch.
- Electronic thermostat for fan control.
- Thermostatic control on the valve and continuous fan operation.
- Simultaneous thermostatic control on the valves and fan.
- Cannot be used with speed switch (master-slave).

ID	Code
SEL2M	9079109

- Speed switch (slave).
- It allows to control up to 8 units with only one centralized thermostat using one speed switch for each unit.
- For controls:
WM-T, WM-TQR and TMO-503-SV2.



Description	ID	Code
Power unit for WM-AU and T-MB remote control (fitted on the unit)	UPM-AU	9066641
Power unit for WM-AU and T-MB remote control (not fitted on the unit)	UP-AU	9066640



Control power absorption: 2,3 VA

Power unit to be installed on the fan coil (fan coil interface).

- It controls the fan and the valves of the fan coil.
- It is connected to the electric supply.
- It receives the information required from the control.

TMM low temperature cut-out thermostat

ID	Code
TMM	9053048

To be installed in contact with the hot water circuit.
 To eliminate cold air blow. Installed by the installing engineer.
 To be used with WM-T control.
 For units working on heating only.
 It stops the fan when the water temperature is lower than 30°C and it starts the fan when is higher than 38°C.

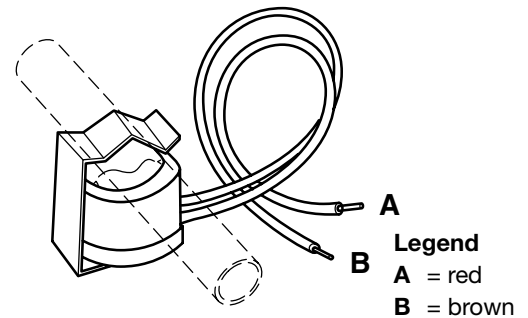

NTC low temperature cut-out thermostat

ID	Code
NTC	3021090



To be fitted between the coil fins. When connecting the control, the NTC probe cable must be separated from the power supply wires.
 To be used with WM-TQR control and UP-AU power unit.
 It stops the fan when the water temperature is lower than 28°C and it starts the fan when is higher than 33°C.

Change-Over CH 15-25

ID	Code
CH 15 -25	9053049

Automatic summer/winter switch to be installed in contact with the water circuit.
 For 2 tube installations only (not to be used with 2 way valve).
 To be used with WM-TQR control.

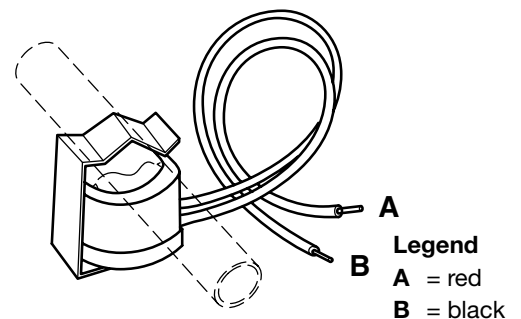

T2 accessory

ID	Code
T2	9025310



To be placed on the water supply pipe upstream 3 way valves (not to be used with 2 way valve).

The **T2** sensor must be used as described below:

- Change-Over for the automatic switch of the operating mode. If water temperature is lower than 20°C, cooling mode is set; on the other hand, if water temperature exceeds 30°C, heating mode is set.
- It can be used on units with electric heater and hot water supply. The T2 priority probe activates the electric heater or water valve, depending on the water temperature detected. If water temperature exceeds 34°C, the water valve ON-OFF control is activated; on the other hand, if water temperature is lower than 30°C, the electric heater is activated.
- To be used with the UP-AU power unit.

Free

Free is an innovative, **fully wireless** electronic system for use with fan coil units, based on radio communication. This technology provides installation flexibility and a **more accurate measurement of the room temperature**.

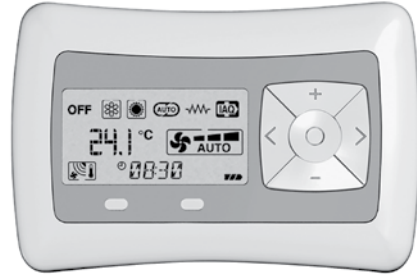

The probe can be moved until the most suitable position is found, without the worry of changes in the room layout and of its furniture and also without mounting it on a wall. If a new fan coil unit is added, no electrical wiring for the control system is required: just define the control unit and the probe which regulates it. The improved measurement accuracy is a result of the possibility to position the probe near the user location: this enables to keep the temperature exactly at the required value with energy savings compared with a traditional measurement system.

Transmission is based on communication protocol IEE802.15.4, the most suitable way to transmit a relatively low amount of information with very low consumption and high reliability.

The system has been certified by a leading independent body, officially recognized by the EU authorities and its sale has been authorized in all the EU and EFTA countries.

Main components

Free includes 3 main components:

- **A remote control** which features a button panel and LCD display and can be wall mounted or positioned on a dedicated table support.

It enables the control of all the operating variables of the fan coil units in different configurations. The control is battery powered.

The temperature and the operating speed of the fan coil unit are set with two large buttons featuring user friendly graphics.

Description	ID	Code
Remote control	Free-Com	9060572



Control unit with support

- **A power unit** to be installed on the fan coil (fan coil interface).

It controls the fan and the valves of the fan coil. The power unit is connected to the electric supply.

The power unit receives the information required to control the fan coil both from the remote control and locally, such as the temperature of the coil.

Description	ID	Code
Power unit fitted on the unit	Free-Upm	9060571
Power unit not fitted on the unit	Free-Ups	9060570



Power unit

- **A room temperature probe**, which can be wall mounted or positioned on a dedicated table support.

It is a battery powered device, able to measure the air temperature in the spot where it is positioned, generating temperature information which is communicated to the other devices.

Description	ID	Code
Temperature probe	Free-Sen	9060573



Probe with support

Free Wireless control system

Main features of the remote control

The control enables:

- Fan coil on/off switching
- Fan speed selection (high - medium - low - automatic)
- Summer/winter operation selection
- Valve on/off
- Real time clock setting
- Temperature setting
- Daily switch on/off setting (timer function)
- Enable/disable the timer function
- Activation of the (eventual) electrostatic filter
- Activation of the (eventual) electric resistance



Main information displayed:

- 1 = On-off status
- 2 = Summer operation
- 3 = Winter operation
- 4 = Automatic season change
- 5 = Electric resistance
- 6 = Crystall filter
- 7 = Room temperature (with decimal accuracy)
- 8 = Fan operating speed
- 9 = Required/measured temperature
- 10 = Timer
- 11 = Clock
- 12 = Transmission signal
- 13 = Battery level

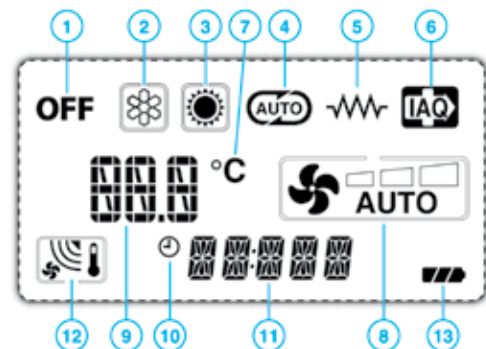

Main features of the power unit to be installed on the fan coil

The power unit controls the fan and the valves of the fan coil. The power unit receives the information required to control such units both from the remote control and locally.



It enables the following main actions:

- Fan on/off at a set speed
- Fan speed change (fan on/off)
- Water valve/s on/off (1 valve for 2 tube system - 2 valves for 4 tube system)
- Fan speed change operating the water valve/s
- Control of the electric resistance as main heating unit or as integration to the battery supplied with hot water
- Control of the operation of the electrostatic filter (in parallel to the fan)
- Management of the dead zone function for 4-tube systems
- Available functional inputs:
 - Consent for remote on/off
 - Consent for remote Summer/Winter switch (centralized)
 - Consent for the activation of the Energy Saving function with setting change
 - Minimum probe
 - Probe for season change

Main features of the temperature probe

This device is able to measure the temperature of the air in the spot where it is positioned and to transmit it by means of radio communication to the other devices in the system. It is battery powered and can be freely positioned in the area to be air-conditioned.

Display:

- Measured environment temperature
- Transmission signal
- Clock
- Battery status



All the **SEC/OW** units can be supplied with a wide range of controls, which allows managing one single unit or several units by using the Modbus RTU - RS 485 communication protocol.

Units can be managed according to the Master/Slave logic (up to 20 units) or by supervisory components.

The system consists in a **MB** board and a series of controls, such as the **T-MB** wall control, the **RT03** infra-red remote control, the **PSM-DI** multifunction control and the **NET** supervisory program.



T-MB WALL CONTROL

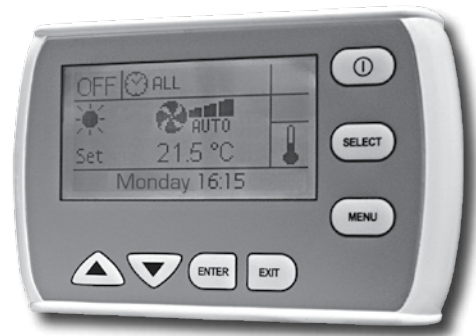

PSM-DI MULTIFUNCTION CONTROL



RT03 INFRA-RED REMOTE CONTROL



NET SOFTWARE

All the controls for the **MB** version and their functions are described in detail from **Page 43**.

ECM Version

One Way Cassette Fan Coil with EC Brushless Electronic Motor and Inverter Board

CONSTRUCTIONAL FEATURES OF THE MAIN COMPONENTS

Casing

Made from 1 mm galvanized steel insulated with polyolefin (PO) foam (class M1).

Diffuser with intake grille

In prepainted metal sheet in RAL 9003 colour with intake grille that can be opened for inspection and maintenance of the air filter.

Air Filter

Polypropylene cellular fabric regenerating filter.

Fan Assembly

The fans have aluminium or plastic blades directly keyed on the motor with double aspiration and they are dynamically and statically balanced during manufacture in order to have an extremely quiet operation.

Electronic motor

Three phase permanent magnet brushless electronic motor that is controlled with current reconstructed according to a BLAC sinusoidal wave. The inverter board that controls the motor operation is powered by 230 Volt, single-phase and, with a switching system, it generates a three-phase frequency modulated, wave form power supply. The electric power supply required for the machine is therefore single-phase with voltage of 230-240V and frequency of 50-60Hz.

Heat exchange coil

It is manufactured from drawn copper tube and the aluminium fins are mechanically bonded onto the tube by an expansion process. The coil has two 1/2 inch BSP internal connections and 1/8 inch BSP air vent and drain.

The heat exchanger is not suitable for use in corrosive atmosphere or in environments where aluminium may be subject to corrosion.

The connection side cannot be changed on site.

Condensate Collection Tray

Made of "L"-shaped plastic (ABS UL94 HB) fitted on the inner casing; the tray is insulated with polyolefin (PO) foam (class M1). The outside diameter of the condensate discharge pipe is 15mm.

Round diffuser

The SEC/OW one-way cassette units are supplied with round diffusers suitably designed to generate an airflow with "coanda" effect. The direction of diffuser air flow can be adjusted on site.

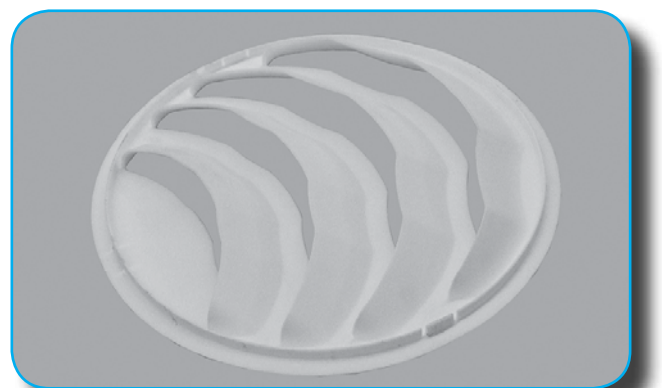

SEC/OW-ECM Gr 1 - 3 diffusers

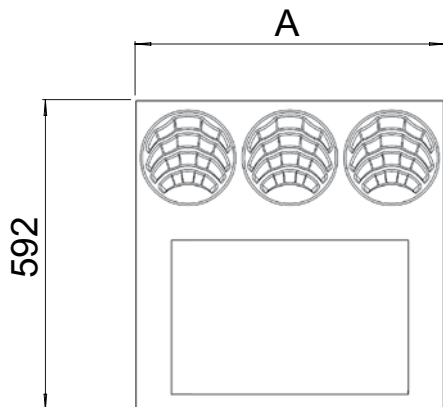

SEC/OW-ECM Gr 2 - 5 diffusers

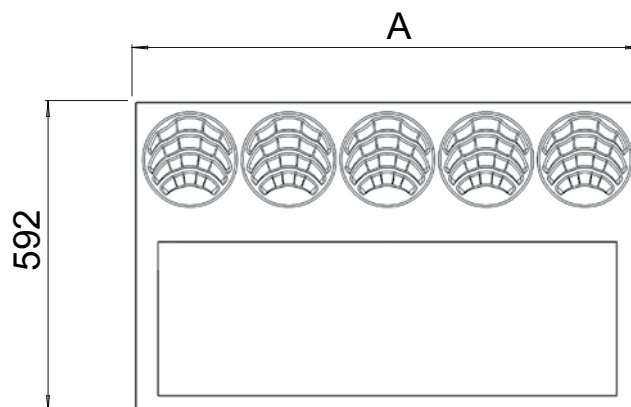

SEC/OW-ECM Gr 3 - 6 diffusers

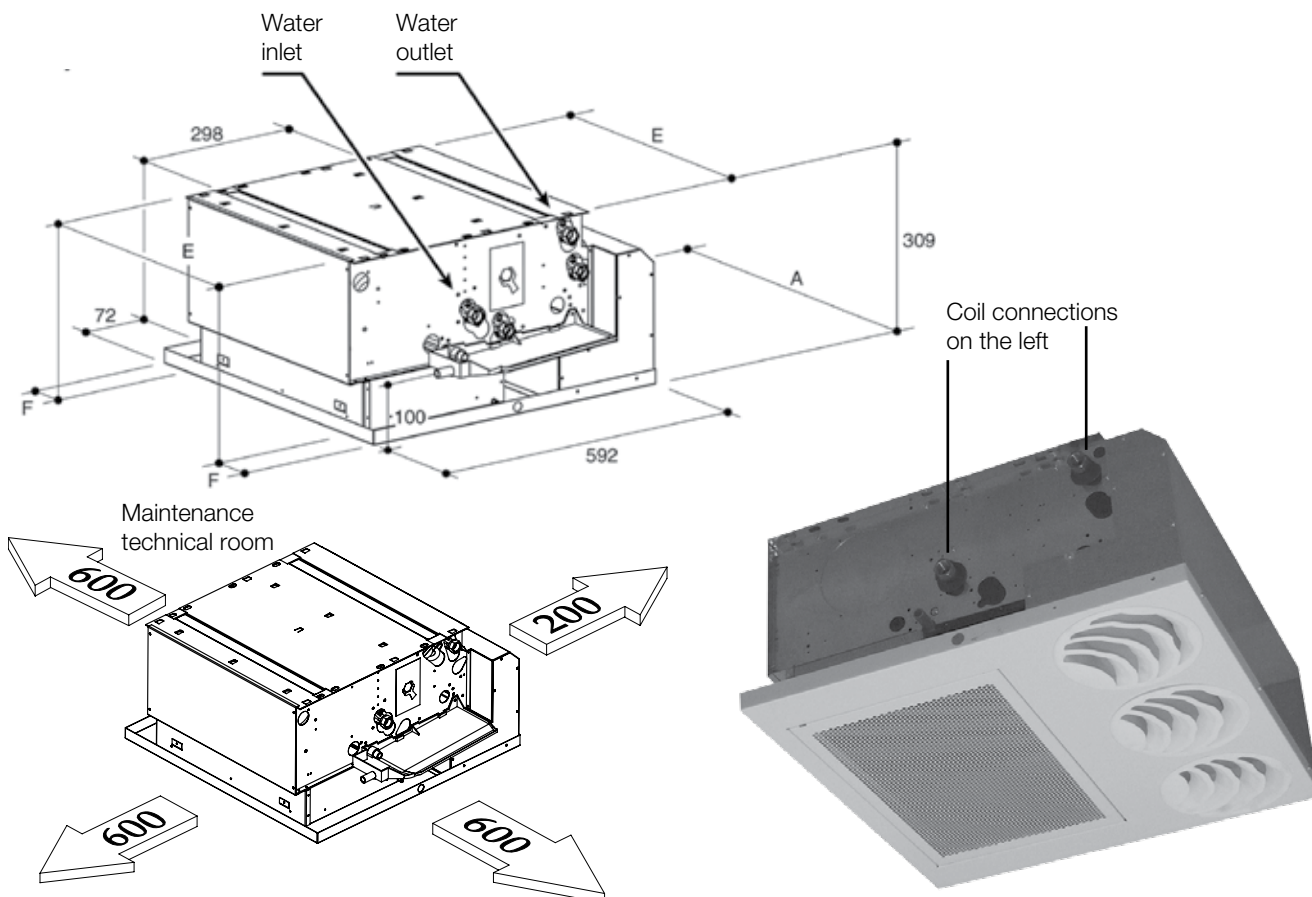
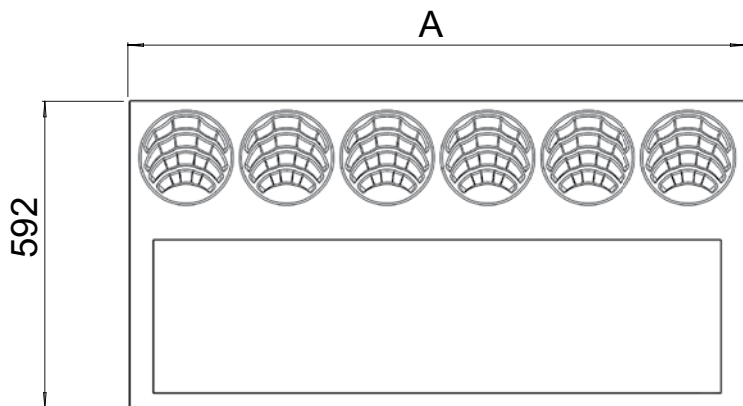

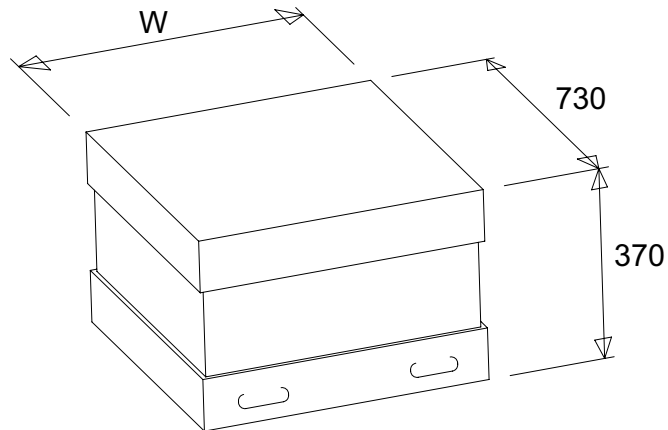

DIMENSIONS (mm)

<i>MODEL</i>	1	2	3
A	592	970	1192
E	454	884	1099
F	78	43	46,5
W	750	1130	1350

WEIGHT (kg)

<i>MODEL</i>		<i>Weight packed unit</i>			<i>Weight unpacked unit</i>		
		1	2	3	1	2	3
ROWS	3	18	34	44	16	33	42
	3+1	20	40	51	19	38	48
	3+2	23	46	58	22	43	54
	4	20	37	48	18	35	45
	4+1	23	42	54	21	40	51

WATER CONTENT (l)

<i>MODEL</i>		1	2	3
ROWS	3	0,6	1,3	1,7
	4	0,8	1,7	2,4
	+1	0,2	0,4	0,5
	+2	0,4	0,8	1,0

2-pipe units

The following standard rating conditions are used:

COOLING (summer operation)

Entering air temperature: + 27°C d.b. / + 19°C w.b.

Water temperature: + 7°C E.W.T. / + 12°C L.W.T.

HEATING (winter operation)

Entering air temperature: + 20°C

Water temperature: + 50°C E.W.T.

Water flow rate as for the cooling conditions

MODEL		SEC/OW-ECM 1.3-2T					SEC/OW-ECM 2.3-2T					SEC/OW-ECM 3.3-2T				
		1	3	5	7,5	10	1	3	5	7,5	10	1	3	5	7,5	10
Speed		MIN		MED		MAX	MIN		MED		MAX	MIN		MED		MAX
Air flow	m³/h	130	165	205	250	295	215	295	370	450	540	275	345	430	525	620
Cooling total emission	kW	0,82	1,00	1,18	1,37	1,56	1,46	1,92	2,31	2,74	3,16	1,87	2,31	2,78	3,28	3,75
Cooling sensible emission	kW	0,62	0,76	0,91	1,07	1,24	1,07	1,42	1,73	2,07	2,41	1,37	1,70	2,06	2,45	2,83
Heating	kW	1,02	1,25	1,50	1,75	2,02	1,72	2,28	2,79	3,33	3,85	2,19	2,72	3,30	3,93	4,54
ΔP Cooling	kPa	2,1	3,0	4,0	5,2	6,5	3,2	5,2	7,3	9,8	12,6	5,8	8,4	11,7	15,7	19,8
ΔP Heating	kPa	1,7	2,4	3,3	4,3	5,3	2,6	4,2	6,0	8,0	10,4	4,7	6,9	9,4	12,9	16,6
Fan	W	8	11	14	21	29	8	11	16	24	37	10	13	19	29	42
Sound power	Lw	35	41	46	51	55	34	40	46	52	56	36	42	48	54	58
Sound pressure (*)	Lp	26	32	37	42	46	25	31	37	43	47	27	33	39	45	49

MODEL		SEC/OW-ECM 1.4-2T					SEC/OW-ECM 2.4-2T					SEC/OW-ECM 3.4-2T				
		1	3	5	7,5	10	1	3	5	7,5	10	1	3	5	7,5	10
Speed		MIN		MED		MAX	MIN		MED		MAX	MIN		MED		MAX
Air flow	m³/h	130	165	205	250	295	215	295	370	450	540	275	345	430	525	620
Cooling total emission	kW	0,91	1,12	1,34	1,58	1,81	1,55	2,06	2,51	3,00	3,50	1,95	2,42	2,94	3,49	4,02
Cooling sensible emission	kW	0,66	0,82	0,99	1,18	1,38	1,11	1,49	1,84	2,21	2,60	1,41	1,76	2,15	2,57	2,98
Heating	kW	1,07	1,32	1,60	1,90	2,20	1,82	2,46	3,03	3,68	4,32	2,25	2,82	3,44	4,12	4,78
ΔP Cooling	kPa	4,1	5,9	8,1	10,9	13,9	5,0	8,2	11,6	15,9	20,8	4,3	6,4	8,9	12,1	15,5
ΔP Heating	kPa	3,3	4,8	6,6	9,0	11,6	4,1	6,7	9,4	13,2	17,1	3,5	5,2	7,4	10,0	13,0
Fan	W	8	11	14	21	29	8	11	16	24	37	10	13	19	29	42
Sound power	Lw	35	41	46	51	55	34	40	46	52	56	36	42	48	54	58
Sound pressure (*)	Lp	26	32	37	42	46	25	31	37	43	47	27	33	39	45	49

4-pipe units

The following standard rating conditions are used:

COOLING (summer operation)

Entering air temperature: + 27°C d.b. / + 19°C w.b.

Water temperature: + 7°C E.W.T. / + 12°C L.W.T.

HEATING (winter operation)

Entering air temperature: + 20°C

Water temperature: + 70°C E.W.T. / + 60°C L.W.T.

MODEL		SEC/OW-ECM 1.3-4T					SEC/OW-ECM 2.3-4T					SEC/OW-ECM 3.3-4T				
		1	3	5	7,5	10	1	3	5	7,5	10	1	3	5	7,5	10
Speed		MIN		MED		MAX	MIN		MED		MAX	MIN		MED		MAX
Air flow	m³/h	130	165	205	250	295	215	295	370	450	540	275	345	430	525	620
Cooling total emission	kW	0,82	1,00	1,18	1,37	1,56	1,46	1,92	2,31	2,74	3,16	1,87	2,31	2,78	3,28	3,75
Cooling sensible emission	kW	0,62	0,76	0,91	1,07	1,24	1,07	1,42	1,73	2,07	2,41	1,37	1,70	2,06	2,45	2,83
Heating	kW	0,87	1,03	1,18	1,35	1,52	1,58	1,97	2,31	2,66	3,01	2,04	2,42	2,82	3,24	3,64
ΔP Cooling	kPa	2,1	3,0	4,0	5,2	6,5	3,2	5,2	7,3	9,8	12,6	5,8	8,4	11,7	15,7	19,8
ΔP Heating	kPa	1,4	1,9	2,5	3,1	3,8	1,0	1,5	2,0	2,5	3,1	1,8	2,5	3,3	4,2	5,1
Fan	W	8	11	14	21	29	8	11	16	24	37	10	13	19	29	42
Sound power	Lw	35	41	46	51	55	34	40	46	52	56	36	42	48	54	58
Sound pressure (*)	Lp	26	32	37	42	46	25	31	37	43	47	27	33	39	45	49

(*) = The sound pressure levels are 9 dB(A) lower than the sound power levels and apply to the reverberant field of a 100 m³ room and a reverberation time of 0.5 sec.

WORKING CONDITIONS

Max. entering water temperature..... + 80 °C
 Min. entering water temperature..... + 5 °C
 for entering water temperatures below + 5°C, contact our technical department
 Max. rated pressure 1000 kPa (10 bars)

Installation height (m)

MODEL	1	2	3
Minimum	2,6	2,6	2,6
Maximum	3,2	3,2	3,5

Water flow limits for main coil (l/h)

MODEL	3 rows			4 rows		
	13	23	33	14	24	34
Minimum	100	150	150	100	150	200
Maximum	500	1000	1500	750	1000	2000

Water flow limits for additional coil (l/h)

MODEL	1 row			2 rows		
	1	2	3	1	2	3
Minimum	50	100	100	50	100	100
Maximum	250	450	650	250	450	650

Motor electrical data (max. absorption)

MODEL		1	2	3
230/1 50Hz	W	29	37	42
	A	0,242	0,29	0,35

AIR THROW

C1 - Heating

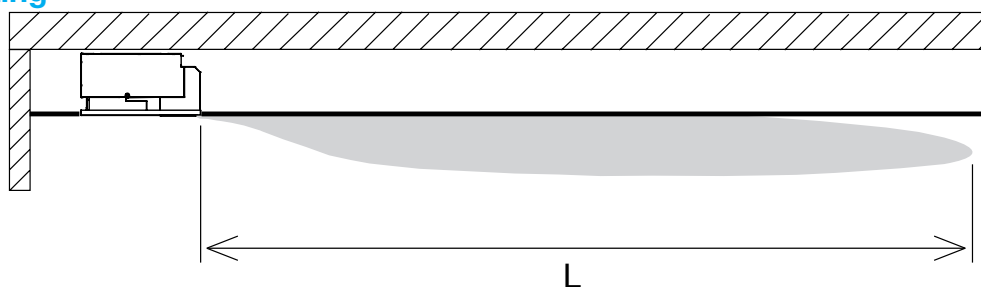

C2 - Cooling

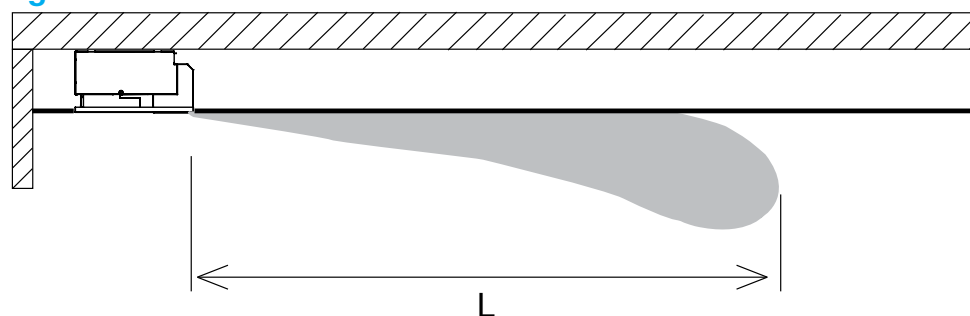

MODEL		SEC/OW-ECM 1						SEC/OW-ECM 2						SEC/OW-ECM 3					
		1	2	3	4	5	6	1	2	3	4	5	6	1	2	3	4	5	6
Air throw L (m)	C1	3,8	4,5	5,8	6,3	6,8	7,2	4	5	6,1	7	8	9	4,5	5,2	6,3	7,5	8,8	9,5
	C2	3	3,6	4,6	5	5,4	5,7	3,2	4	4,8	5,6	6,4	7,2	3,6	4,1	5	6	7	7,6

Cooling emission of 3 row coil

Entering air temperature: +27°C - Relative Humidity: 50%

Model	Vdc	Qv m³/h	WT: 7/12 °C				WT: 8/13 °C				WT: 10/15 °C				WT: 12/17 °C			
			Pc kW	Ps kW	Qw l/h	Dp(c) kPa	Pc kW	Ps kW	Qw l/h	Dp(c) kPa	Pc kW	Ps kW	Qw l/h	Dp(c) kPa	Pc kW	Ps kW	Qw l/h	Dp(c) kPa
SEC/OW-ECM 1.3-2T	10	295	1,69	1,23	291	7,5	1,50	1,16	258	6,1	1,11	1,01	191	3,5	0,89	0,89	153	2,3
	7,5	250	1,48	1,07	255	6,0	1,32	1,01	227	4,8	0,98	0,88	169	2,8	0,77	0,77	132	1,8
	5	205	1,27	0,91	218	4,6	1,14	0,85	196	3,7	0,85	0,74	146	2,2	0,65	0,65	112	1,4
	3	165	1,08	0,76	186	3,4	0,97	0,71	167	2,8	0,72	0,62	124	1,7	0,55	0,55	95	1,0
	1	130	0,89	0,62	153	2,4	0,80	0,58	138	2,0	0,60	0,51	103	1,2	0,45	0,45	77	0,7
SEC/OW-ECM 2.3-2T	10	540	3,40	2,41	585	14,3	3,05	2,26	525	11,7	2,31	1,97	397	7,1	1,74	1,74	299	4,3
	7,5	450	2,94	2,06	506	11,1	2,64	1,94	454	9,1	2,01	1,69	346	5,5	1,49	1,49	256	3,2
	5	370	2,49	1,73	428	8,3	2,23	1,62	384	6,8	1,70	1,41	292	4,2	1,25	1,25	215	2,4
	3	295	2,06	1,42	354	5,9	1,85	1,33	318	4,9	1,42	1,16	244	3,0	1,03	1,03	177	1,7
	1	215	1,57	1,07	270	3,7	1,42	1,01	244	3,0	1,09	0,87	187	1,9	0,77	0,77	132	1,0
SEC/OW-ECM 3.3-2T	10	620	4,03	2,82	693	22,5	3,63	2,65	624	18,6	2,77	2,31	476	11,4	2,04	2,04	351	6,6
	7,5	525	3,53	2,45	607	17,8	3,17	2,30	545	14,7	2,43	2,01	418	9,0	1,77	1,77	304	5,1
	5	430	2,99	2,06	514	13,3	2,69	1,93	463	11,0	2,06	1,68	354	6,8	1,49	1,49	256	3,8
	3	345	2,48	1,70	427	9,6	2,24	1,59	385	7,9	1,72	1,39	296	4,9	1,23	1,23	212	2,7
	1	275	2,01	1,37	346	6,6	1,82	1,28	313	5,5	1,40	1,12	241	3,4	0,98	0,98	169	1,8

Entering air temperature: +26°C - Relative Humidity: 50%

Model	Vdc	Qv m³/h	WT: 7/12 °C				WT: 8/13 °C				WT: 10/15 °C				WT: 12/17 °C			
			Pc kW	Ps kW	Qw l/h	Dp(c) kPa	Pc kW	Ps kW	Qw l/h	Dp(c) kPa	Pc kW	Ps kW	Qw l/h	Dp(c) kPa	Pc kW	Ps kW	Qw l/h	Dp(c) kPa
SEC/OW-ECM 1.3-2T	10	295	1,49	1,16	256	6,0	1,31	1,09	225	4,8	0,97	0,97	167	2,8	0,81	0,81	139	2,0
	7,5	250	1,31	1,01	225	4,8	1,15	0,94	198	3,8	0,84	0,84	144	2,1	0,70	0,70	120	1,5
	5	205	1,13	0,85	194	3,7	0,99	0,80	170	2,9	0,70	0,69	120	1,6	0,60	0,60	103	1,2
	3	165	0,96	0,72	165	2,8	0,85	0,67	146	2,2	0,60	0,57	103	1,2	0,50	0,50	86	0,9
	1	130	0,79	0,58	136	2,0	0,70	0,55	120	1,6	0,50	0,47	86	0,9	0,41	0,41	71	0,6
SEC/OW-ECM 2.3-2T	10	540	3,03	2,27	521	11,7	2,68	2,12	461	9,3	1,92	1,83	330	5,1	1,59	1,59	273	3,6
	7,5	450	2,63	1,95	452	9,1	2,32	1,82	399	7,3	1,68	1,57	289	4,1	1,36	1,36	234	2,8
	5	370	2,22	1,63	382	6,8	1,97	1,52	339	5,4	1,43	1,31	246	3,1	1,15	1,15	198	2,0
	3	295	1,84	1,34	316	4,9	1,63	1,25	280	3,9	1,19	1,07	205	2,2	0,94	0,94	162	1,4
	1	215	1,41	1,01	243	3,0	1,25	0,94	215	2,4	0,92	0,81	158	1,4	0,71	0,71	122	0,9
SEC/OW-ECM 3.3-2T	10	620	3,60	2,66	619	18,5	3,20	2,49	550	14,9	2,32	2,15	399	8,4	1,87	1,87	322	5,6
	7,5	525	3,15	2,31	542	14,6	2,80	2,16	482	11,8	2,04	1,86	351	6,7	1,62	1,62	279	4,4
	5	430	2,67	1,94	459	10,9	2,38	1,81	409	8,8	1,74	1,56	299	5,0	1,37	1,37	236	3,2
	3	345	2,22	1,60	382	7,9	1,98	1,50	341	6,4	1,45	1,29	249	3,7	1,12	1,12	193	2,3
	1	275	1,80	1,29	310	5,5	1,61	1,20	277	4,4	1,19	1,03	205	2,6	0,90	0,90	155	1,6

Entering air temperature: +25°C - Relative Humidity: 50%

Model	Vdc	Qv m³/h	WT: 7/12 °C				WT: 8/13 °C				WT: 10/15 °C				WT: 12/17 °C			
			Pc kW	Ps kW	Qw l/h	Dp(c) kPa	Pc kW	Ps kW	Qw l/h	Dp(c) kPa	Pc kW	Ps kW	Qw l/h	Dp(c) kPa	Pc kW	Ps kW	Qw l/h	Dp(c) kPa
SEC/OW-ECM 1.3-2T	10	295	1,31	1,09	225	4,8	1,12	1,01	193	3,6	0,89	0,89	153	2,4	0,73	0,73	126	1,7
	7,5	250	1,15	0,94	198	3,8	0,99	0,88	170	2,9	0,77	0,77	132	1,9	0,63	0,63	108	1,3
	5	205	0,99	0,80	170	2,9	0,85	0,74	146	2,2	0,65	0,65	112	1,4	0,54	0,54	93	1,0
	3	165	0,84	0,67	144	2,2	0,73	0,62	126	1,7	0,55	0,55	95	1,0	0,46	0,46	79	0,7
	1	130	0,70	0,55	120	1,6	0,60	0,51	103	1,2	0,45	0,45	77	0,7	0,37	0,37	64	0,5
SEC/OW-ECM 2.3-2T	10	540	2,67	2,13	459	9,4	2,32	1,98	399	7,2	1,74	1,74	299	4,3	1,44	1,44	248	3,1
	7,5	450	2,32	1,82	399	7,3	2,01	1,70	346	5,7	1,49	1,49	256	3,3	1,24	1,24	213	2,3
	5	370	1,96	1,53	337	5,4	1,71	1,42	294	4,2	1,26	1,26	217	2,4	1,04	1,04	179	1,7
	3	295	1,63	1,25	280	3,9	1,42	1,17	244	3,1	1,03	1,03	177	1,7	0,85	0,85	146	1,2
	1	215	1,24	0,95	213	2,4	1,09	0,88	187	1,9	0,77	0,77	132	1,0	0,64	0,64	110	0,7
SEC/OW-ECM 3.3-2T	10	620	3,19	2,50	549	14,9	2,78	2,33	478	11,6	2,05	2,05	353	6,7	1,70	1,70	292	4,7
	7,5	525	2,79	2,16	480	11,8	2,43	2,02	418	9,2	1,77	1,77	304	5,2	1,47	1,47	253	3,7
	5	430	2,37	1,82	408	8,8	2,07	1,69	356	6,9	1,50	1,50	258	3,9	1,24	1,24	213	2,7
	3	345	1,97	1,50	339	6,4	1,72	1,39	296	5,0	1,23	1,23	212	2,7	1,02	1,02	175	1,9
	1	275	1,60	1,21	275	4,4	1,40	1,12	241	3,5	0,96	0,95	165	1,8	0,82	0,82	141	1,3

Correction factors for different R.H.

U.R.	WT:	7/12°C	8/13°C	10/15°C	12/17°C
48%	Pc	0,95	0,94	1,00	1,00
	Ps	1,00	1,00	1,00	1,00
46%	Pc	0,90	0,88	1,00	1,00
	Ps	1,00	1,00	1,00	1,00

Legend

- WT = Water temperature
- Vdc = Inverter power
- Qv = Air flow
- Dp(c) = Water side pressure drop
- Pc = Cooling Total emission
- Qw = Water flow
- Ps = Cooling Sensible emission

Cooling emission of 4 row coil

Entering air temperature: +27°C - Relative Humidity: 50%

Model	Vdc	WT: 7/12 °C					WT: 8/13 °C				WT: 10/15 °C				WT: 12/17 °C			
		Qv m³/h	Pc kW	Ps kW	Qw l/h	Dp(c) kPa	Pc kW	Ps kW	Qw l/h	Dp(c) kPa	Pc kW	Ps kW	Qw l/h	Dp(c) kPa	Pc kW	Ps kW	Qw l/h	Dp(c) kPa
SEC/OW-ECM 1.4-2T	10	295	1,95	1,37	335	15,9	1,75	1,29	301	13,0	1,33	1,12	229	7,8	0,99	0,99	170	4,7
	7,5	250	1,70	1,18	292	12,4	1,52	1,11	261	10,2	1,16	0,97	200	6,2	0,85	0,85	146	3,6
	5	205	1,44	0,99	248	9,2	1,29	0,93	222	7,6	0,98	0,81	169	4,6	0,72	0,72	124	2,6
	3	165	1,20	0,82	206	6,8	1,08	0,77	186	5,6	0,83	0,67	143	3,4	0,60	0,60	103	1,9
	1	130	0,98	0,66	169	4,7	0,88	0,62	151	3,9	0,68	0,54	117	2,4	0,48	0,48	83	1,3
SEC/OW-ECM 2.4-2T	10	540	3,76	2,60	647	23,6	3,38	2,44	581	19,5	2,59	2,12	445	12,1	1,88	1,88	323	6,7
	7,5	450	3,22	2,21	554	18,0	2,90	2,08	499	14,9	2,23	1,81	384	9,3	1,60	1,60	275	5,1
	5	370	2,69	1,83	463	13,2	2,43	1,72	418	10,9	1,87	1,50	322	6,8	1,33	1,33	229	3,7
	3	295	2,21	1,49	380	9,3	1,99	1,40	342	7,7	1,54	1,22	265	4,8	1,08	1,08	186	2,5
	1	215	1,66	1,12	286	5,6	1,50	1,05	258	4,7	1,16	0,91	200	2,9	0,77	0,76	132	1,4
SEC/OW-ECM 3.4-2T	10	620	4,32	2,98	743	17,6	3,89	2,80	669	14,6	2,98	2,44	513	9,0	2,15	2,15	370	5,0
	7,5	525	3,75	2,57	645	13,7	3,38	2,41	581	11,4	2,60	2,10	447	7,1	1,86	1,86	320	3,9
	5	430	3,15	2,15	542	10,1	2,85	2,02	490	8,4	2,19	1,75	377	5,2	1,55	1,55	267	2,8
	3	345	2,60	1,76	447	7,2	2,35	1,65	404	6,0	1,81	1,44	311	3,7	1,27	1,27	218	2,0
	1	275	2,09	1,41	359	4,9	1,89	1,32	325	4,1	1,46	1,15	251	2,6	0,97	0,96	167	1,2

Entering air temperature: +26°C - Relative Humidity: 50%

Model	Vdc	WT: 7/12 °C					WT: 8/13 °C				WT: 10/15 °C				WT: 12/17 °C			
		Qv m³/h	Pc kW	Ps kW	Qw l/h	Dp(c) kPa	Pc kW	Ps kW	Qw l/h	Dp(c) kPa	Pc kW	Ps kW	Qw l/h	Dp(c) kPa	Pc kW	Ps kW	Qw l/h	Dp(c) kPa
SEC/OW-ECM 1.4-2T	10	295	1,74	1,29	299	13,0	1,54	1,21	265	10,3	1,11	1,04	191	5,7	0,91	0,91	157	4,0
	7,5	250	1,51	1,11	260	10,1	1,34	1,04	230	8,1	0,97	0,89	167	4,5	0,78	0,78	134	3,1
	5	205	1,28	0,93	220	7,6	1,14	0,87	196	6,1	0,83	0,75	143	3,4	0,66	0,66	114	2,2
	3	165	1,08	0,78	186	5,5	0,95	0,73	163	4,5	0,70	0,62	120	2,5	0,55	0,55	95	1,6
	1	130	0,87	0,63	150	3,8	0,78	0,58	134	3,1	0,57	0,50	98	1,8	0,44	0,44	76	1,1
SEC/OW-ECM 2.4-2T	10	540	3,36	2,45	578	19,4	2,99	2,29	514	15,7	2,19	1,97	377	8,9	1,72	1,72	296	5,8
	7,5	450	2,88	2,08	495	14,9	2,57	1,95	442	12,0	1,89	1,68	325	6,9	1,46	1,46	251	4,3
	5	370	2,41	1,73	415	10,8	2,15	1,62	370	8,8	1,58	1,39	272	5,1	1,22	1,22	210	3,1
	3	295	1,98	1,41	341	7,6	1,76	1,32	303	6,2	1,31	1,13	225	3,6	0,99	0,99	170	2,2
	1	215	1,49	1,05	256	4,6	1,33	0,98	229	3,8	0,99	0,84	170	2,2	0,74	0,74	127	1,3
SEC/OW-ECM 3.4-2T	10	620	3,87	2,81	666	14,5	3,43	2,63	590	11,7	2,52	2,26	433	6,7	1,97	1,97	339	4,3
	7,5	525	3,36	2,42	578	11,3	2,99	2,26	514	9,1	2,19	1,95	377	5,2	1,71	1,71	294	3,3
	5	430	2,82	2,02	485	8,3	2,52	1,89	433	6,8	1,85	1,62	318	3,9	1,42	1,42	244	2,4
	3	345	2,33	1,66	401	5,9	2,08	1,55	358	4,8	1,54	1,33	265	2,8	1,16	1,16	200	1,7
	1	275	1,87	1,33	322	4,1	1,67	1,24	287	3,3	1,24	1,06	213	1,9	0,93	0,93	160	1,1

Entering air temperature: +25°C - Relative Humidity: 50%

Model	Vdc	WT: 7/12 °C					WT: 8/13 °C				WT: 10/15 °C				WT: 12/17 °C			
		Qv m³/h	Pc kW	Ps kW	Qw l/h	Dp(c) kPa	Pc kW	Ps kW	Qw l/h	Dp(c) kPa	Pc kW	Ps kW	Qw l/h	Dp(c) kPa	Pc kW	Ps kW	Qw l/h	Dp(c) kPa
SEC/OW-ECM 1.4-2T	10	295	1,54	1,21	265	10,4	1,33	1,13	229	8,0	1,00	1,00	172	4,7	0,82	0,82	141	3,4
	7,5	250	1,34	1,04	230	8,1	1,16	0,97	200	6,3	0,86	0,86	148	3,6	0,71	0,71	122	2,6
	5	205	1,13	0,88	194	6,1	0,99	0,81	170	4,7	0,72	0,72	124	2,7	0,60	0,60	103	1,9
	3	165	0,95	0,73	163	4,5	0,83	0,68	143	3,5	0,60	0,60	103	1,9	0,50	0,50	86	1,4
	1	130	0,77	0,59	132	3,1	0,68	0,54	117	2,4	0,46	0,46	79	1,2	0,40	0,40	69	0,9
SEC/OW-ECM 2.4-2T	10	540	2,98	2,30	513	15,7	2,60	2,14	447	12,3	1,88	1,88	323	6,9	1,56	1,56	268	4,9
	7,5	450	2,56	1,95	440	12,0	2,23	1,82	384	9,4	1,60	1,60	275	5,2	1,33	1,33	229	3,7
	5	370	2,14	1,62	368	8,8	1,87	1,51	322	6,9	1,28	1,27	220	3,5	1,11	1,11	191	2,7
	3	295	1,76	1,32	303	6,2	1,54	1,23	265	4,9	1,06	1,04	182	2,5	0,90	0,90	155	1,8
	1	215	1,32	0,99	227	3,8	1,16	0,92	200	3,0	0,81	0,77	139	1,6	0,67	0,67	115	1,1
SEC/OW-ECM 3.4-2T	10	620	3,42	2,63	588	11,7	2,99	2,45	514	9,2	2,16	2,16	372	5,1	1,79	1,79	308	3,6
	7,5	525	2,97	2,27	511	9,1	2,60	2,11	447	7,2	1,87	1,87	322	4,0	1,55	1,55	267	2,8
	5	430	2,50	1,90	430	6,8	2,19	1,77	377	5,3	1,50	1,49	258	2,7	1,29	1,29	222	2,0
	3	345	2,07	1,55	356	4,8	1,81	1,45	311	3,8	1,25	1,22	215	1,9	1,06	1,06	182	1,4
	1	275	1,66	1,24	286	3,3	1,46	1,16	251	2,6	1,02	0,98	175	1,4	0,84	0,84	144	1,0

Correction factors for different R.H.

U.R.	WT:	7/12°C	8/13°C	10/15°C	12/17°C
48%	Pc	0,95	0,94	1,00	1,00
	Ps	1,00	1,00	1,00	1,00
46%	Pc	0,90	0,88	1,00	1,00
	Ps	1,00	1,00	1,00	1,00

Legend

- WT = Water temperature
- Vdc = Inverter power
- Qv = Air flow
- Dp(c) = Water side pressure drop
- Pc = Cooling Total emission
- Qw = Water flow
- Ps = Cooling Sensible emission

Heating emission of 3 row coil

Entering air temperature: +20°C

Model	Vdc	WT: 70/60°C				WT: 60/50°C			WT: 50/40°			WT: 50/45°			WT: 45/40°		
		Qv m³/h	Ph kW	Qw l/h	Dp(c) kPa	Ph kW	Qw l/h	Dp(c) kPa	Ph kW	Qw l/h	Dp(c) kPa	Ph kW	Qw l/h	Dp(c) kPa	Ph kW	Qw l/h	Dp(c) kPa
SEC/OW-ECM 1.3-2T	10	295	3,44	296	6,0	2,63	226	3,9	1,82	313	2,1	2,10	361	9,1	1,70	292	6,4
	7,5	250	2,98	256	4,7	2,28	196	3,0	1,58	272	1,6	1,82	313	7,0	1,47	253	4,9
	5	205	2,54	218	3,5	1,94	167	2,3	1,35	232	1,2	1,55	267	5,3	1,26	217	3,7
	3	165	2,12	182	2,6	1,62	139	1,7	1,13	194	0,9	1,30	224	3,9	1,05	181	2,7
	1	130	1,72	148	1,8	1,32	114	1,1	0,92	158	0,6	1,05	181	2,7	0,85	146	1,9
SEC/OW-ECM 2.3-2T	10	540	6,49	558	10,2	4,98	428	6,6	3,47	597	3,6	3,96	681	15,4	3,21	552	10,9
	7,5	450	5,60	482	7,9	4,30	370	5,1	3,00	516	2,8	3,42	588	11,9	2,78	478	8,4
	5	370	4,67	402	5,8	3,59	309	3,7	2,51	432	2,1	2,85	490	8,6	2,32	399	6,1
	3	295	3,82	329	4,0	2,94	253	2,6	2,06	354	1,4	2,34	402	6,1	1,90	327	4,3
	1	215	2,88	248	2,4	2,22	191	1,6	1,55	267	0,9	1,76	303	3,7	1,43	246	2,6
SEC/OW-ECM 3.3-2T	10	620	7,61	654	15,8	5,85	503	10,3	4,09	703	5,6	4,65	800	23,8	3,77	648	16,8
	7,5	525	6,59	567	12,3	5,07	436	8,0	3,55	611	4,4	4,03	693	18,5	3,27	562	13,0
	5	430	5,53	476	9,0	4,25	366	5,9	2,98	513	3,2	3,38	581	13,5	2,74	471	9,6
	3	345	4,54	390	6,4	3,50	301	4,2	2,45	421	2,3	2,78	478	9,6	2,26	389	6,8
	1	275	3,65	314	4,3	2,82	243	2,8	1,98	341	1,6	2,23	384	6,5	1,82	313	4,6

Heating emission of 4 row coil

Entering air temperature: +20°C

Model	Vdc	WT: 70/60°C				WT: 60/50°C			WT: 50/40°			WT: 50/45°			WT: 45/40°		
		Qv m³/h	Ph kW	Qw l/h	Dp(c) kPa	Ph kW	Qw l/h	Dp(c) kPa	Ph kW	Qw l/h	Dp(c) kPa	Ph kW	Qw l/h	Dp(c) kPa	Ph kW	Qw l/h	Dp(c) kPa
SEC/OW-ECM 1.4-2T	10	295	3,69	317	11,1	2,83	243	7,2	1,97	339	3,9	2,25	387	16,7	1,83	315	11,8
	7,5	250	3,19	274	8,6	2,45	211	5,6	1,71	294	3,1	1,95	335	13,0	1,58	272	9,2
	5	205	2,68	230	6,3	2,06	177	4,1	1,44	248	2,3	1,64	282	9,5	1,33	229	6,7
	3	165	2,22	191	4,5	1,71	147	3,0	1,19	205	1,6	1,36	234	6,8	1,10	189	4,8
	1	130	1,78	153	3,1	1,37	118	2,0	0,96	165	1,1	1,09	187	4,7	0,89	153	3,3
SEC/OW-ECM 2.4-2T	10	540	7,27	625	17,3	5,60	482	11,3	3,93	676	6,3	4,44	764	26,1	3,62	623	18,5
	7,5	450	6,17	531	13,0	4,76	409	8,5	3,35	576	4,7	3,77	648	19,6	3,07	528	13,9
	5	370	5,08	437	9,2	3,93	338	6,0	2,76	475	3,4	3,11	535	13,9	2,53	435	9,9
	3	295	4,11	353	6,3	3,17	273	4,2	2,24	385	2,3	2,51	432	9,6	2,05	353	6,8
	1	215	3,04	261	3,7	2,35	202	2,5	1,66	286	1,4	1,86	320	5,6	1,52	261	4,0
SEC/OW-ECM 3.4-2T	10	620	8,00	688	12,0	6,16	530	7,8	4,31	741	4,3	4,89	841	18,0	3,97	683	12,7
	7,5	525	6,89	593	9,2	5,30	456	6,0	3,72	640	3,3	4,21	724	13,8	3,42	588	9,8
	5	430	5,74	494	6,7	4,43	381	4,4	3,11	535	2,4	3,51	604	10,0	2,85	490	7,1
	3	345	4,70	404	4,7	3,62	311	3,1	2,55	439	1,7	2,87	494	7,1	2,34	402	5,0
	1	275	3,75	323	3,2	2,90	249	2,1	2,04	351	1,2	2,30	396	4,8	1,87	322	3,4

Legend

WT = Water temperature
 Vdc = Inverter power
 Qv = Air flow

Ph = Emission
 Qw = Water flow
 Dp(c) = Water side pressure drop

Heating emission of 1 row additional coil

Entering air temperature: +20°C

Model	Vdc	WT: 80/70°C				WT: 75/65°			WT: 70/60°			WT: 65/55°			WT: 60/50°			WT: 55/45°		
		Qv m³/h	Ph kW	Qw l/h	Dp(c) kPa	Ph kW	Qw l/h	Dp(c) kPa	Ph kW	Qw l/h	Dp(c) kPa	Ph kW	Qw l/h	Dp(c) kPa	Ph kW	Qw l/h	Dp(c) kPa	Ph kW	Qw l/h	Dp(c) kPa
SEC/OW-ECM 1.3-4T 1.4-4T	10	295	1,90	163	5,5	1,71	147	4,7	1,52	131	3,8	1,33	114	3,1	1,14	98	2,4	0,95	82	1,8
	7,5	250	1,69	145	4,5	1,52	131	3,8	1,35	116	3,1	1,18	101	2,5	1,02	88	1,9	0,85	73	1,4
	5	205	1,48	127	3,5	1,33	114	3,0	1,18	101	2,5	1,04	89	2,0	0,89	77	1,5	0,74	64	1,1
	3	165	1,28	110	2,8	1,16	100	2,3	1,03	89	1,9	0,90	77	1,5	0,77	66	1,2	0,64	55	0,9
SEC/OW-ECM 2.3-4T 2.4-4T	1	130	1,09	94	2,1	0,98	84	1,7	0,87	75	1,4	0,76	65	1,2	0,66	57	0,9	0,55	47	0,7
	10	540	3,77	324	4,5	3,39	292	3,8	3,01	259	3,1	2,64	227	2,5	2,26	194	2,0	1,89	163	1,4
	7,5	450	3,33	286	3,6	2,99	257	3,1	2,66	229	2,5	2,33	200	2,0	2,00	172	1,6	1,67	144	1,2
	5	370	2,88	248	2,8	2,59	223	2,4	2,31	199	2,0	2,02	174	1,6	1,74	150	1,2	1,45	125	0,9
	3	295	2,46	212	2,1	2,22	191	1,8	1,97	169	1,5	1,73	149	1,2	1,49	128	0,9	1,24	107	0,7
SEC/OW-ECM 3.3-4T 3.4-4T	1	215	1,97	169	1,4	1,77	152	1,2	1,58	136	1,0	1,38	119	0,8	1,19	102	0,6	1,00	86	0,5
	10	620	4,53	390	7,3	4,08	351	6,2	3,64	313	5,1	3,19	274	4,1	2,75	237	3,2	2,31	199	2,4
	7,5	525	4,04	347	6,0	3,64	313	5,1	3,24	279	4,2	2,85	245	3,4	2,45	211	2,6	2,06	177	2,0
	5	430	3,51	302	4,7	3,17	273	4,0	2,82	243	3,3	2,48	213	2,7	2,14	184	2,1	1,79	154	1,5
	3	345	3,01	259	3,6	2,71	233	3,0	2,42	208	2,5	2,12	182	2,0	1,83	157	1,6	1,54	132	1,2
1	275	2,53	218	2,6	2,28	196	2,2	2,04	175	1,8	1,79	154	1,5	1,54	132	1,2	1,30	112	0,9	

Heating emission of 2 row additional coil

Entering air temperature: +20°C

Model	Vdc	WT: 65/55°C				WT: 60/50°			WT: 55/45°			WT: 50/40°			WT: 45/40°			WT: 45/35°		
		Qv m³/h	Ph kW	Qw l/h	Dp(c) kPa	Ph kW	Qw l/h	Dp(c) kPa	Ph kW	Qw l/h	Dp(c) kPa	Ph kW	Qw l/h	Dp(c) kPa	Ph kW	Qw l/h	Dp(c) kPa	Ph kW	Qw l/h	Dp(c) kPa
SEC/OW-ECM 1.3-4T/2R	10	295	2,32	200	14,8	2,00	172	11,6	1,69	145	8,8	1,37	118	6,2	1,30	224	19,2	1,06	91	4,0
	7,5	250	2,04	175	11,9	1,77	152	9,3	1,49	128	7,0	1,21	104	5,0	1,14	196	15,4	0,94	81	3,2
	5	205	1,77	152	9,2	1,53	132	7,2	1,29	111	5,4	1,05	90	3,9	0,99	170	11,9	0,81	70	2,5
	3	165	1,51	130	6,9	1,30	112	5,5	1,10	95	4,1	0,90	77	2,9	0,84	144	9,0	0,69	59	1,9
SEC/OW-ECM 2.3-4T/2R	1	130	1,26	108	5,1	1,09	94	4,0	0,92	79	3,0	0,75	65	2,2	0,71	122	6,6	0,58	50	1,4
	10	540	4,56	392	12,3	3,94	339	9,7	3,33	286	7,3	2,72	234	5,2	2,55	439	15,9	2,11	181	3,4
	7,5	450	3,98	342	9,6	3,44	296	7,6	2,91	250	5,7	2,38	205	4,1	2,23	384	12,5	1,84	158	2,7
	5	370	3,42	294	7,4	2,97	255	5,8	2,51	216	4,4	2,05	176	3,2	1,92	330	9,6	1,59	137	2,1
	3	295	2,86	246	5,4	2,48	213	4,3	2,10	181	3,2	1,72	148	2,3	1,60	275	7,0	1,33	114	1,5
SEC/OW-ECM 3.3-4T/2R	1	215	2,21	190	3,4	1,91	164	2,7	1,62	139	2,1	1,33	114	1,5	1,24	213	4,4	1,03	89	1,0
	10	620	5,42	466	19,8	4,70	404	15,6	3,98	342	11,8	3,26	280	8,5	3,04	523	25,6	2,54	218	5,6
	7,5	525	4,77	410	15,8	4,14	356	12,5	3,51	302	9,5	2,87	247	6,8	2,67	459	20,5	2,24	193	4,5
	5	430	4,12	354	12,2	3,58	308	9,7	3,03	261	7,3	2,49	214	5,3	2,31	397	15,8	1,94	167	3,5
	3	345	3,45	297	8,9	3,00	258	7,1	2,54	218	5,4	2,08	179	3,9	1,93	332	11,6	1,63	140	2,5
1	275	2,82	243	6,3	2,45	211	5,0	2,08	179	3,8	1,71	147	2,7	1,58	272	8,1	1,33	114	1,8	

Legend

- WT = Water temperature
- Vdc = Inverter power
- Qv = Air flow
- Ph = Emission
- Qw = Water flow
- Dp(c) = Water side pressure drop

3 row coil

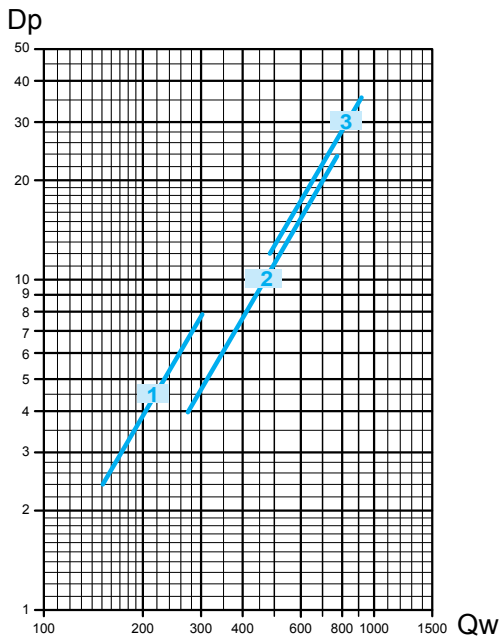

4 row coil

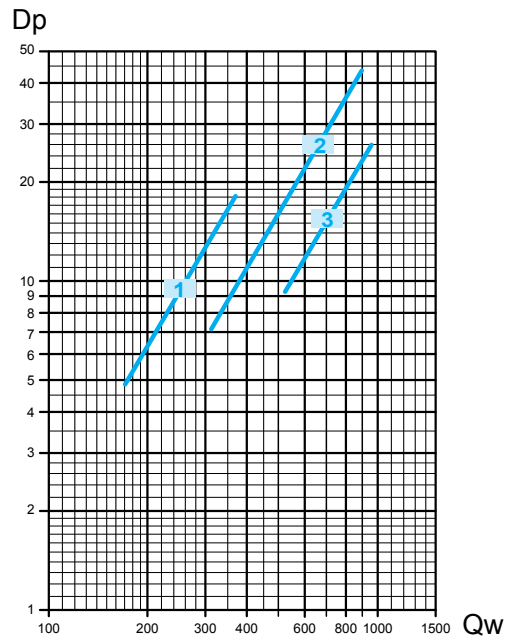

Pressure drop for mean water temperature of 10°C; for different temperatures multiply the pressure drop figure by the K correction factors in the table.

°C	20	30	40	50	60	70	80
K	0,94	0,90	0,86	0,82	0,78	0,74	0,70

1 row additional coil

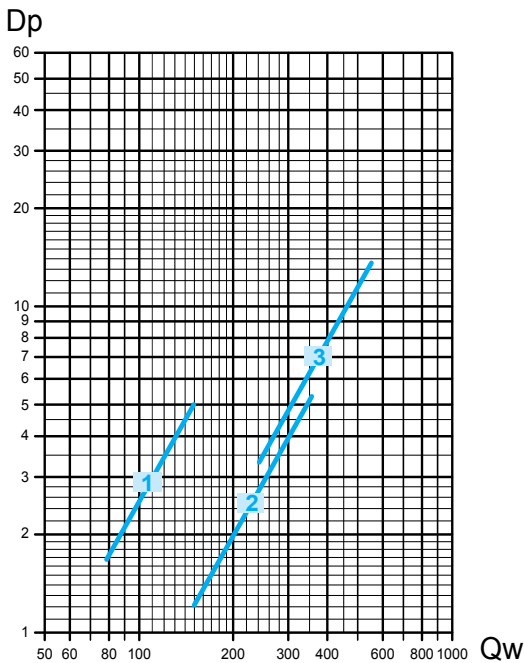

2 row additional coil

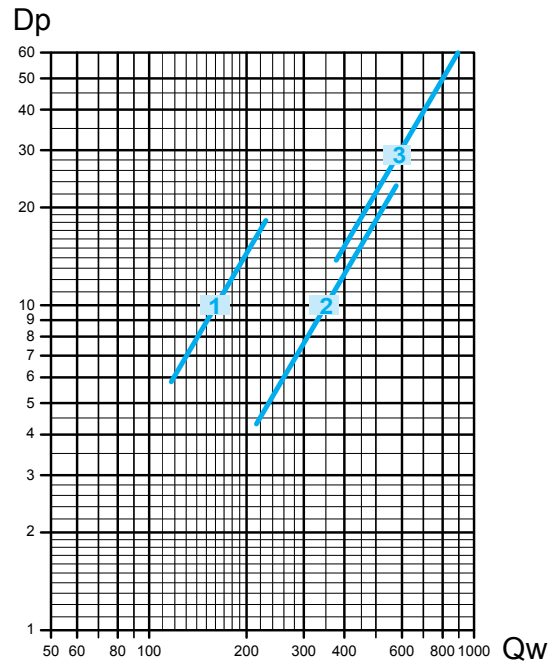

Pressure drop for mean water temperature of 65°C; for different temperatures multiply the pressure drop figure by the K correction factors in the table.

°C	40	50	60	70	80
K	1,14	1,08	1,02	0,96	0,90

Legend

Qw = water flow (l/h)

Dp = pressure drop (kPa)

VBP Main coil 3 way valve

Control valve kit: 3 way valve, ON-OFF, with electric motor and mounting kit with micrometric lockshield valve.

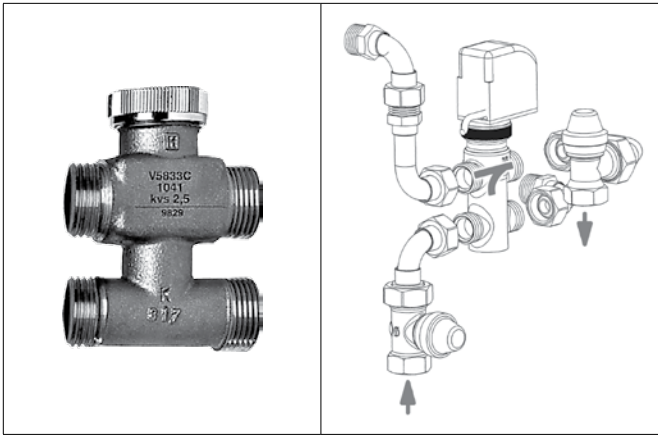

VBA Additional coil 3 way valve

Control valve kit: 3 way valve, ON-OFF, with electric motor and mounting kit with micrometric lockshield valve.

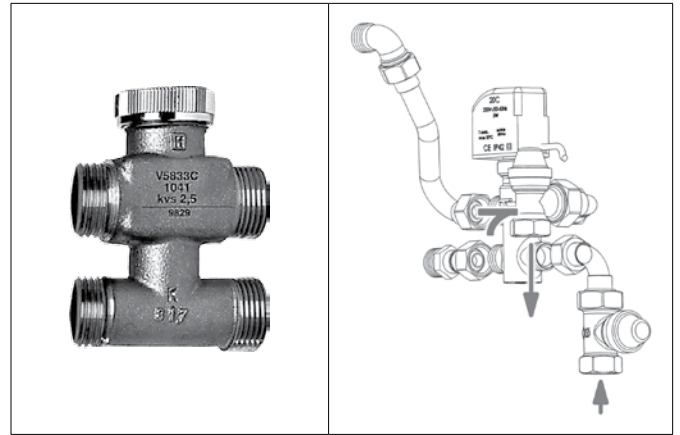

VS Simplified kit for 3 way valve for main and additional coil

3 way valve, (ON-OFF) with electric motor and mounting kit. Valve with flat connection without micrometric lockshield valve.

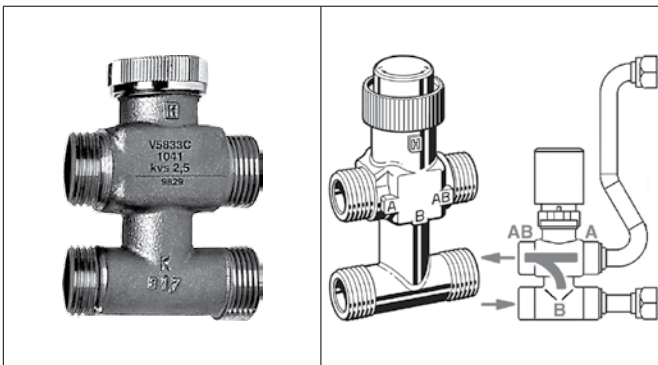

V2 2 way valve for main and additional coil

Control valve kit: 2 way valve, ON-OFF, with electric motor and mounting kit.

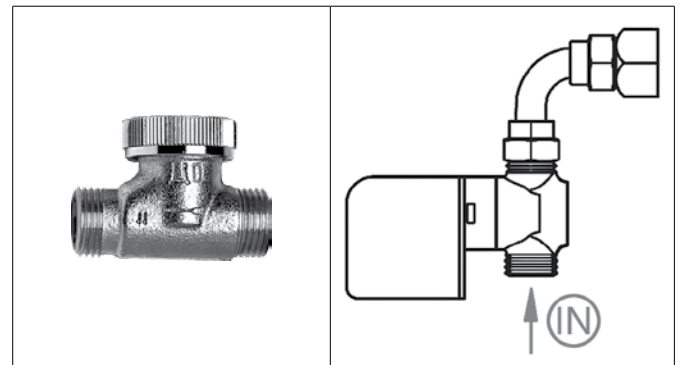

Valve	type	mod.	Valve			Micrometric lockshield valve			Code		Valves pressure drop
			DN	(Ø)	Kvs	DN	(Ø)	Kvs	Fitted	Not Fitted	
VBP	Main	1 - 2	15	1/2"	1,6	15	1/2"	2	9066561H	9066560H	<p>Legend Qw = water flow (l/h) Dp = pressure drop (kPa)</p>
	Main	3	20	3/4"	2,5	15	1/2"	2	9060471H	9060474H	
VBA	Additional	All	15	1/2"	1,6	15	1/2"	2	9060472H	9060475H	
VS	Main	1 - 2	15	1/2"	1,6	-	-	-	9066571H	9066570H	
		3	20	3/4"	2,5	-	-	-	9060484H	9060481H	
	Additional	All	15	1/2"	1,6	-	-	-	9060483H	9060480H	
V2	Main	1 - 2	15	1/2"	1,7	-	-	-	9060476H	9060478H	
		3	20	3/4"	2,8	-	-	-	9060477H	9060479H	
	Additional	All	15	1/2"	1,7	-	-	-	9060476H	9060478H	

- For 3 way double valve kit for 4 tube installation and single coil, refer to page 14.
- For 2 way balance valve, refer to page 15.

BSO Extension condensate collection tray to cover valve assembly

Connection side	BSO	
	left	right
ID	BSO-SX	BSO-DX
Code	6060402	6060403

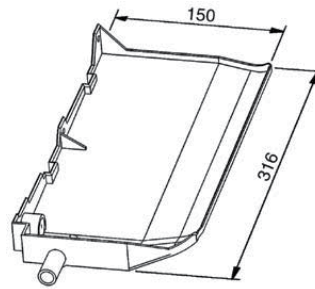

SCR plastic condensate drain pipe with fast connection

It helps regular drainage of condensate thereby preventing the formation of bends.

ID	SCR
Code	6060420

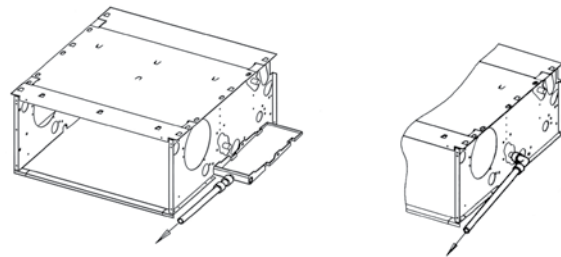

PCC condensate drain pump

ID	Fitted	Not fitted
	PCC-M	PCC-S
Code	9064011	9064010

Height for vertical flow (m)	Water flow (l/h) depending on the length of horizontal flow	
	5 m	10 m
1	6,8	6,3
2	5,5	5,0
3	4,2	3,8
4	3,0	2,6

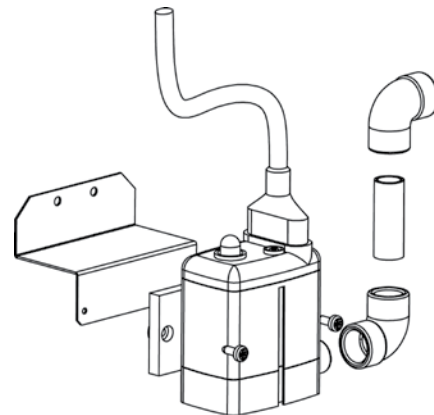

FRC fresh air connection

ID	FRC 100
Code	6064191

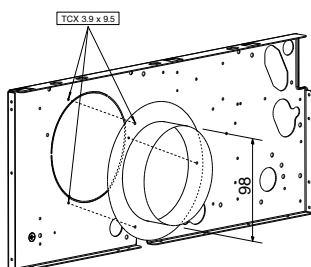

ID	FRC 120
Code	6064192

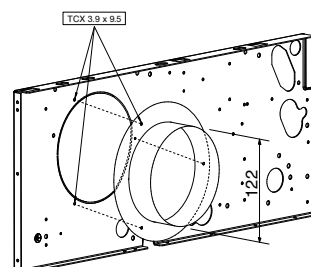

For this fan coil configuration, the 1-10 VDC signal, which controls the inverter, must be supplied by a controller with the following signal specifications:

- Impedance < 100 Ω;
- Maximum speed 10 VDC;
- Fan OFF with U < 0,9 VDC.
- Signal 0,3 / 13 V.

SEC/OW-ECM electric wiring diagram

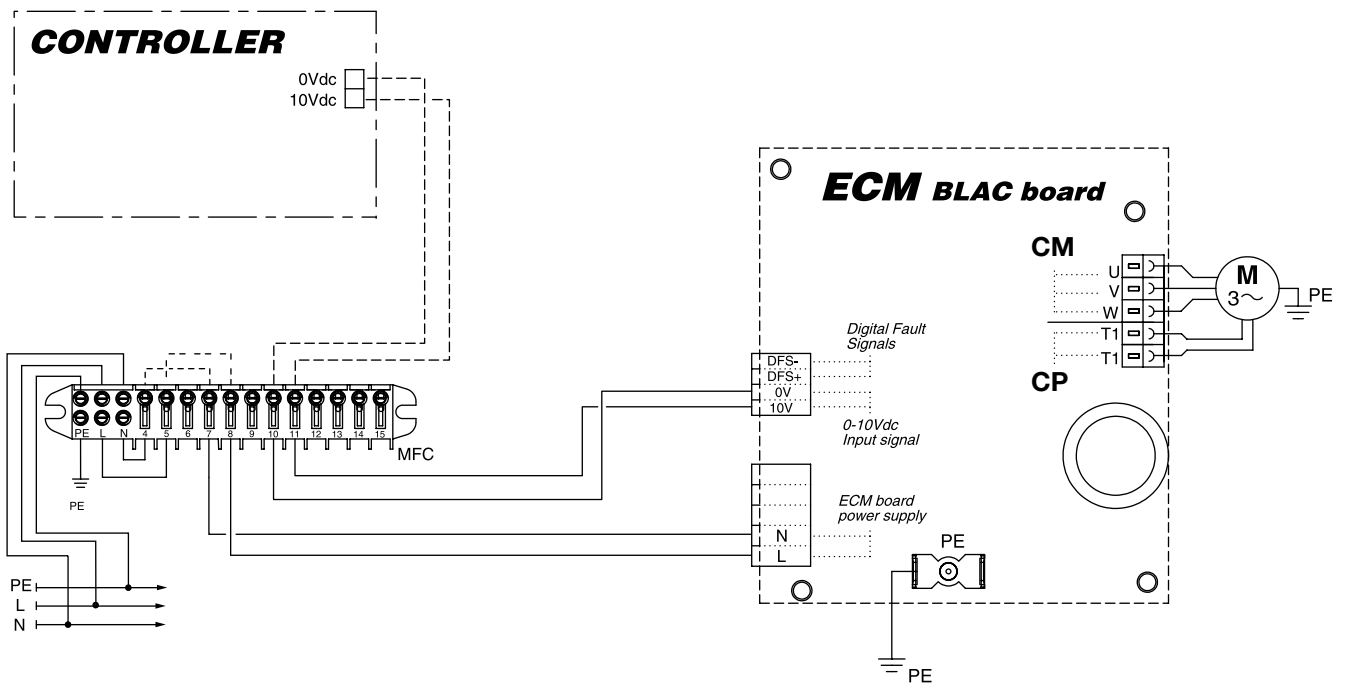

Legend

CONTROLLER	= Controller
ECM BLAC BOARD	= Inverter circuit board
M	= Brushless electronic motor
CM	= Motor fan connection
CP	= Motor fan thermal protection connection

ID	Code
WM-AU	9066632E

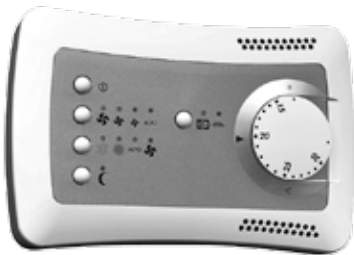

Dimensions: 135x86x24 mm

The control must always be connected with UPM-AU power unit (fitted on the unit) or with UP-AU power unit (not fitted on the unit).

- ON-OFF push button.
- Manual or automatic 3 speed progressive push button.
- Manual, automatic or centralized Summer/Winter switch.
- Summer/Winter/Fan/Auto mode push button.
- Electric heater activation button.
- Electronic room thermostat for fan control (ON-OFF).
- Electronic room thermostat for valve control (ON-OFF).
- Simultaneous thermostatic control of the valves and fan.
- It allows to control the low temperature cut-out thermostat (NTC).
- It allows to control the water valves (ON-OFF) and the electric heater managed as main heating element or as an integration element.
- Energy saving push button.

N.B.: with 4 pipe installations and continuous chilled and hot water supply, it allows the automatic summer winter change-over in accordance to the room temperature (-1°C = Winter, +1°C = Summer, Neutral Zone 2°C).

ID	Code
T-MB	9066331E



Dimensions: 110x72x25 mm

The control must always be connected with UPM-AU power unit (fitted on the unit) or with UP-AU power unit (not fitted on the unit).

Wall control with display that allows controlling one or more units in Master/Slave mode.

The control is equipped with internal sensor to detect the room temperature, which can be defined as a priority compared to the return air sensor on the fan coil.

The T-MB control features the following functions:

- Switch the unit ON and OFF.
- Temperature set.
- Manual, centralized or automatic Summer/Winter switch.
- Set the fan speed (low, medium, high or autofan).
- Set the operation mode (fan only, cooling, heating; auto for 4 pipe systems with mode selection depending on the air temperature.)
- It allows to control the water valves (ON-OFF) and the electric heater managed as main heating element or as an integration element.
- Time setting.
- Weekly ON/OFF program.

ID	Code
WM-S-ECM	9066644



Dimensions: 132x87x23,6 mm

0-10V control with display designed to be mounted on the wall or to be installed on a 503 wall box.

- ON-OFF switch.
- Manual 3 speed switch or automatic continuous speed control.
- Manual Summer/Winter switch.
- Summer/Winter/Fan/Auto mode push button.
- Electronic room thermostat for fan control (ON-OFF).
- Electronic room thermostat for valve control (ON-OFF).
- Simultaneous thermostatic control of the valves and fan.
- It allows to control the low temperature cut-out thermostat (NTC).

Description	ID	Code
Power unit for WM-AU and T-MB remote control (fitted on the unit)	UPM-AU	9066641
Power unit for WM-AU and T-MB remote control (not fitted on the unit)	UP-AU	9066640



Control power absorption: 2,3 VA

- Power unit to be installed on the fan coil (fan coil interface).
- It controls the fan and the valves of the fan coil.
 - It is connected to the electric supply.
 - It receives the information required from the control.

NTC low temperature cut-out thermostat

ID	Code
NTC	3021090



To be fitted between the coil fins; when connecting the control, the NTC probe cable must be separated from the power supply wires.

To be used with the WM-S-ECM control and UP-AU power unit.

It stops the fan when the water temperature is lower than 28°C and it starts the fan when is higher than 33°C.

T2 accessory

ID	Code
T2	9025310



To be placed on the water supply pipe upstream 3 way valves (not to be used with 2 way valve).

The **T2** sensor must be used as described below:

- Change-Over for the automatic switch of the operating mode. If water temperature is lower than 20°C, cooling mode is set; on the other hand, if water temperature exceeds 30°C, heating mode is set.
- It can be used on units with electric heater and hot water supply. The T2 priority probe activates the electric heater or water valve, depending on the water temperature detected. If water temperature exceeds 34°C, the water valve ON-OFF control is activated; on the other hand, if water temperature is lower than 30°C, the electric heater is activated.
- To be used with the UP-AU power unit.

All the **SEC/OW-ECM** units can be supplied with a wide range of controls, which allows managing one single unit or several units by using the Modbus RTU - RS 485 communication protocol.

Units can be managed according to the Master/Slave logic (up to 20 units) or by supervisory components.

The system consists in a **MB** board and a series of controls, such as the **T-MB** wall control, the **RT03** infra-red remote control, the **PSM-DI** multifunction control and the **NET** supervisory program.



T-MB WALL CONTROL



PSM-DI MULTIFUNCTION CONTROL



RT03 INFRA-RED REMOTE CONTROL



NET SOFTWARE

All the controls for the **MB** version and their functions are described in detail from Page 43.

Controls and units MB version

MB electronic board

Description	Version	ID	Code
<i>MB electronic board fitted on the unit</i>	SEC/OW	MB-M	9066332
<i>MB electronic board supplied with separate packaging</i>	SEC/OW	MB-S	9066333
<i>MB electronic board fitted on the unit</i>	SEC/OW-ECM	MB-ECM-M	9066334
<i>MB electronic board supplied with separate packaging</i>	SEC/OW-ECM	MB-ECM-S	9066335

The **MB** electronic board, to be mounted on the fan coil internal unit, is set to carry out different functions and adjustment modes, in order to meet the installation requirements. These modes are selected by setting the configuration dip switches on the board.

- 2/4 pipe system.
- Fan ON/OFF thermostatic control.
- Valve ON/OFF thermostatic control and continuous ventilation.
- Valve and simultaneous ventilation ON/OFF thermostatic control.
- Fan operation control depending on the coil temperature (cut-out T3 probe fitted), which can be activated only in heating mode or heating and cooling mode.
- Automatic switch of the operating mode by means of T2 water probe (optional) applied on the 2 pipe system.
- Seasonal switch by means of remote contact.
- ON/OFF of the fan coil by means of the remote contact (window or clock contact).
- Electric heater control



By activating the cut-out T3 probe function, the fan is stopped in winter when the coil temperature is lower than 32°C and started when the temperature reaches 36°C. In summer mode, the fan stops when the temperature inside the coil exceeds 22°C and starts when it drops below 18°C.

The following connections are located on the power board:

- Receiver for infra-red remote control.
- T-MB wall control.
- RS 485 serial connection to manage several fan coils in Master/Slave configuration or to create a supervisory network.

T-MB wall control

Description	ID	Code
Wall control (to be used with MB board only)	T-MB	9066331E

Wall control with display that allows controlling one or more units in Master/Slave mode. The control is equipped with internal sensor to detect the room temperature, which can be defined as a priority compared to the return air sensor on the fan coil.



Dimensions: 110x72x25 mm

The **T-MB** control features the following functions:

- Switch the appliance ON and OFF.
- Temperature set.
- Modify the set point (when used as a +/- 3° variation of the set point configured from NET supervisory program or PSM-DI).
- Set the fan speed (low, medium, high or autofan).
- Set the operation mode (fan only, cooling, heating; auto for 4 pipe systems with mode selection depending on the air temperature).
- Time setting.
- Weekly ON/OFF program.
- Display and change of the fan coil operation parameters.

Controls and units MB version

RT03 infra-red remote control

Description	ID	Code
RT03 infra-red remote control with receiver supplied with separate packaging (to be used with MB board only)	RS-RT03	9066337
RT03 infra-red remote control supplied with separate packaging (to be used with MB board only)	RT03	3021203
Receiver for RT03 infra-red remote control supplied with separate packaging (to be used with MB board only)	RS	9066338

The infra-red remote control allows setting by a remote position the fan coil operation parameters.

The **RT03** infra-red remote control features the following functions:

- Switch the appliance ON and OFF.
- Temperature set.
- Set the fan speed (low, medium, high or autofan).
- Set the operation mode (fan only, cooling, heating; auto for 4 pipe systems with mode selection depending on the air temperature).
- Time setting.
- 24 hours ON/OFF program.



ID	Code
RT03	3021203

INSTALLATION EXAMPLE WITH INFRA-RED REMOTE CONTROL



ID	Code
RS-RT03	9066337



ID	Code
RS	9066338

A group of **SEC/OW** units with **MB** electronic board can be connected via a serial link and can consequently be managed at the same time by just one **T-MB** wall control or **RT03** infra-red remote control. Using the special jumper present on the MB board, one unit must be configured as the master, and all the others as slaves. It is clear that the remote control must be pointed at the receiver on the master unit. To avoid problems, it is recommended to install and connect the receiver only on the master unit.

With T-MB wall control

One control for each unit
(MAXIMUM LENGTH OF THE CONNECTION CABLE = 20 M)



One control for more units
(20 units max.)
(MAXIMUM TOTAL LENGTH OF THE CONNECTION CABLE = 800 M)

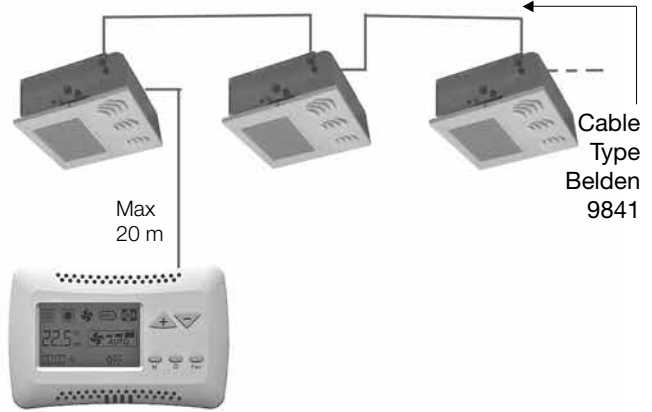

With RT03 infra-red remote control

One control for each unit



One control for more units
(20 units max.)
(MAXIMUM TOTAL LENGTH OF THE CONNECTION CABLE = 800 M)

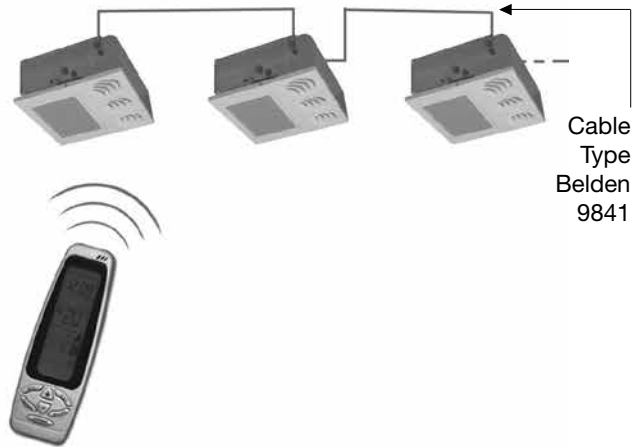

T2 accessory for units with MB electronic board

ID	Code
T2	9025310



The **T2** sensor can be combined with **MB** boards to be placed on the water supply pipe upstream 3 way valves (not to be used with 2 way valve). The **T2** sensor must be used as described below:

- Change-Over for 2-pipe system for the automatic switch of the operating mode. If water temperature is lower than 20°C, cooling mode is set; on the other hand, if water temperature exceeds 30°C, heating mode is set.
- It can be used on units with electric heater and hot water supply. The **T2** priority probe activates the electric heater or water valve, depending on the water temperature detected. If water temperature exceeds 34°C, the water valve ON-OFF control is activated; on the other hand, if water temperature is lower than 30°C, the electric heater is activated.

Controls and units MB version

PSM-DI Multifunction control panel

Description	ID	Code
Multifunction control (to be used with MB board only)	PSM-DI	3021293

Another option available for the serial communication between the units is the possibility to connect up to 60 **SEC/OW** units in series and manage them with just one wall mounted **PSM-DI** controller.

The wall mounted controller can be used to set the operating mode for each individual unit connected, display the operating conditions of each individual unit, and set the ON/OFF time sets for each day of the week (the program can be set for all the units and for a maximum of two groups of units).

If more than 60 units need to be connected, two or more controllers must be used. Each unit must have a MB board.

The **PSM-DI** control is used to manage a series of fan coils, up to a maximum of 60 units (the maximum length of the RS 485 connection cable must not exceed 800 m), from one single control point.

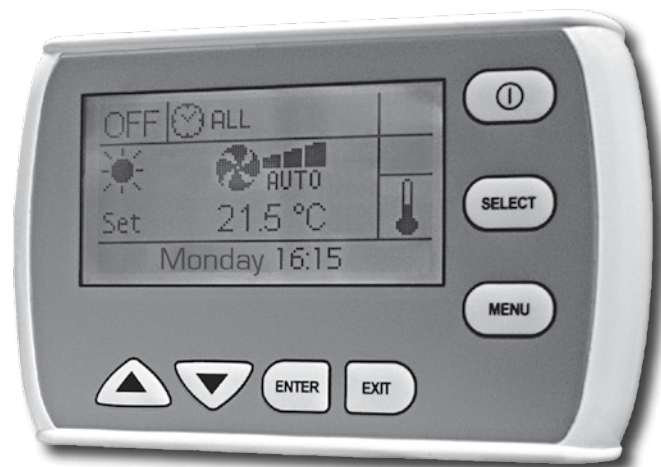

The **PSM-DI** control communicates via a serial line with all the units connected, with the possibility of controlling them all together or individually. In fact, the unique address of each individual fan coil means that all the units can be called at the same time, or the individual unit called, to perform the following functions:

- display the current operating mode, the fan speed, the set point;
- display the room temperature measured on the individual unit;
- turn all the units ON and OFF at the same time or alternatively each unit individually;
- change the operating mode (fan only, heating, cooling, automatic changeover);
- change the set point;
- modify the values and operation parameters of the fan speed.

Each function can then be sent to all the units connected, or alternatively to each individual unit.

Different set points or operating modes can be set for each individual unit.

The **PSM-DI** panel can also be used for the time management of the units over the week. Four ON times and four OFF times can be set on the units for each day of the week. A different Temperature set that will be considered as Operation set for all connected appliances, can be set for each event. If the Temperature set is not entered for the individual event, it must be set during programming for each individual unit or for the entire network.

Units without receiver or with receiver can be connected within the network: the former can receive instructions only from the **PSM-DI** wall mounted panel; while the latter can receive information from both the wall mounted panel (**PSM-DI**) and infra-red remote control. Use the infra-red remote control to force ON mode of the individual unit, if ON/OFF daily time programming has been set. The unit will regain the settings from the **PSM-DI** panel during execution of successive start-up program.

The PSM-DI panel cannot be used together with the NET management program (see next page).

Note: set the configuration Dip Switches of each fan coil as illustrated in the remote control use manual, based on the required solutions.

Note: the RS 485 network's overall length must not exceed 700/800 metres.

NET program for managing a network of MB fan coils

Description	ID	Code
Hardware/software supervisory system (to be used with MB board only)	NET	9079118

NET is a centralised control system for networks of MB fan coils, based on software that runs on LINUX™ operating system (the program is provided pre-installed on a Pc). The **NET** software offers a practical and economical solution for managing the units, with the simple click of the mouse. The main characteristics include simplicity of use, an extremely complete and functional weekly program, and the possibility to access the historical operating data for each individual unit connected.

The program exploits all the potential of our units with remote controls, representing an addition to the latter.

The **NET** program is a control tool that can be used as a replacement for the remote control, or in parallel, however the settings made using **NET** can have priority over those made using the remote control.



The program can be used to:

- Create uniform groups (groups of units on individual floors, in offices or rooms).
- Save weekly programs configured for different types of operation (summer, winter, mid seasons, closing periods etc.); these can then be recalled and activated with a simple click of the mouse.
Weekly on/off cycles can be set for individual units or groups of units.
- Set the operating conditions for each individual unit or groups of units (operating mode, fan speed, temperature setting).
- Set the set point limits for each individual unit or groups of units.
- Switch each individual unit or groups of units ON or OFF.

The main program screen can display and interact with the entire network of units. An individual unit, a group of units or the entire network can be called so as to make modifications to the operating mode and the set point. The user can then check the operating status of each individual unit, read the room temperature, the coil temperature and the operating status of the condensate drain pump or any alarms.



PC NET Software

Connection of a SEC/OW network with MB electronic board

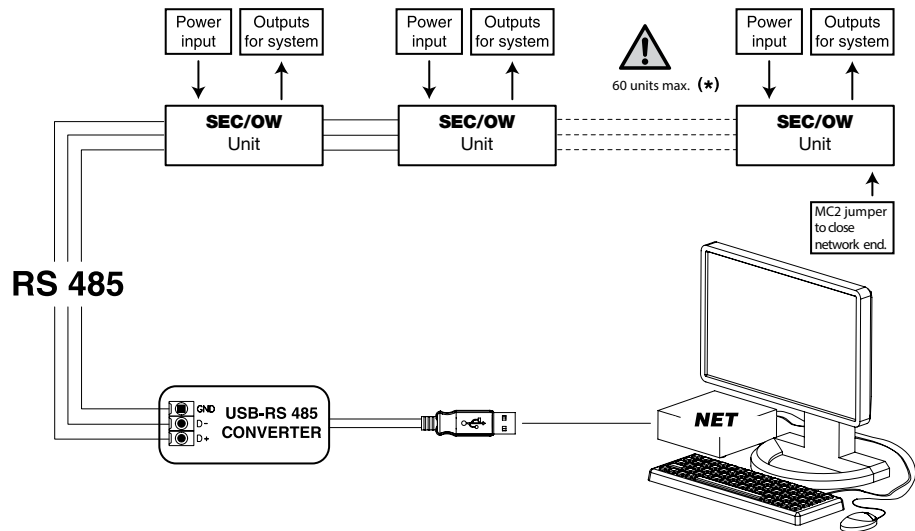

(*) In the event of more than 60 units, add one or more Router-S (see below).

RS 485 serial connection cable

Shielded cable to be used:

Belden 9841, RS-485, 1x2x24 AWG SFTP, 120 Ohm



PSM-DI and NET electronic boards for SEC/OW units

ID	Code
SIOS	3021292

SIOS is a board equipped with 8 relays with potential free contact to control the activation or deactivation of remote electric utilities. Moreover, the board has 8 digital inlets to display the actuators or external consents, such as motor or other. The SIOS boards can be connected:

- inside a network managed by NET;
- to a PSM-DI panel (one SIOS for each PSM-DI panel).

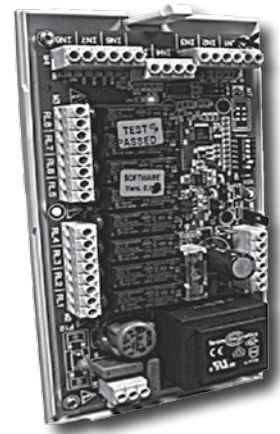

ID	Code
Router-S	3021290

The **Router-S** is an electronic board that:

- allows creating networks with more than 60 units (minimum 2 Router-S are required) or to divide the network (per floor, building, etc.);
- allows creating a Master/Slave sub-network to be controlled as an independent group.

The Router-S can be used only inside a network managed by NET.

- The number of Router-S to be used is:
- up to 60 units: no Router-S
 - from 61 to 120 units: 2 Router-S
 - every 60 subsequent units: 1 additional Router-S

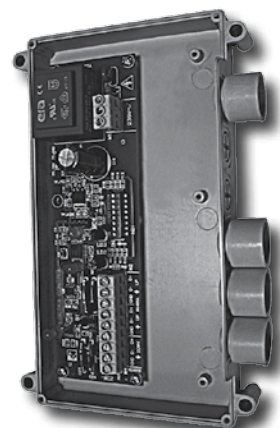

The descriptions and illustrations provided in this publication are not binding: we reserve the right, whilst maintaining the essential characteristics of the types described and illustrated, to make, at any time, without the requirement to promptly update this piece of literature, any changes that we consider useful for the purpose of improvement or for any other manufacturing or commercial requirements.

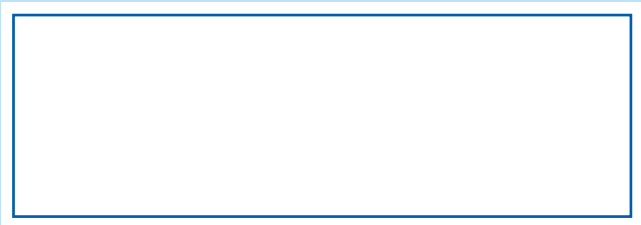

SEC/OW - 12/15

COD. A4640170 D/12/15