

Carisma

The Fan Coil Unit
with Low Energy Consumption
Tangential Fan

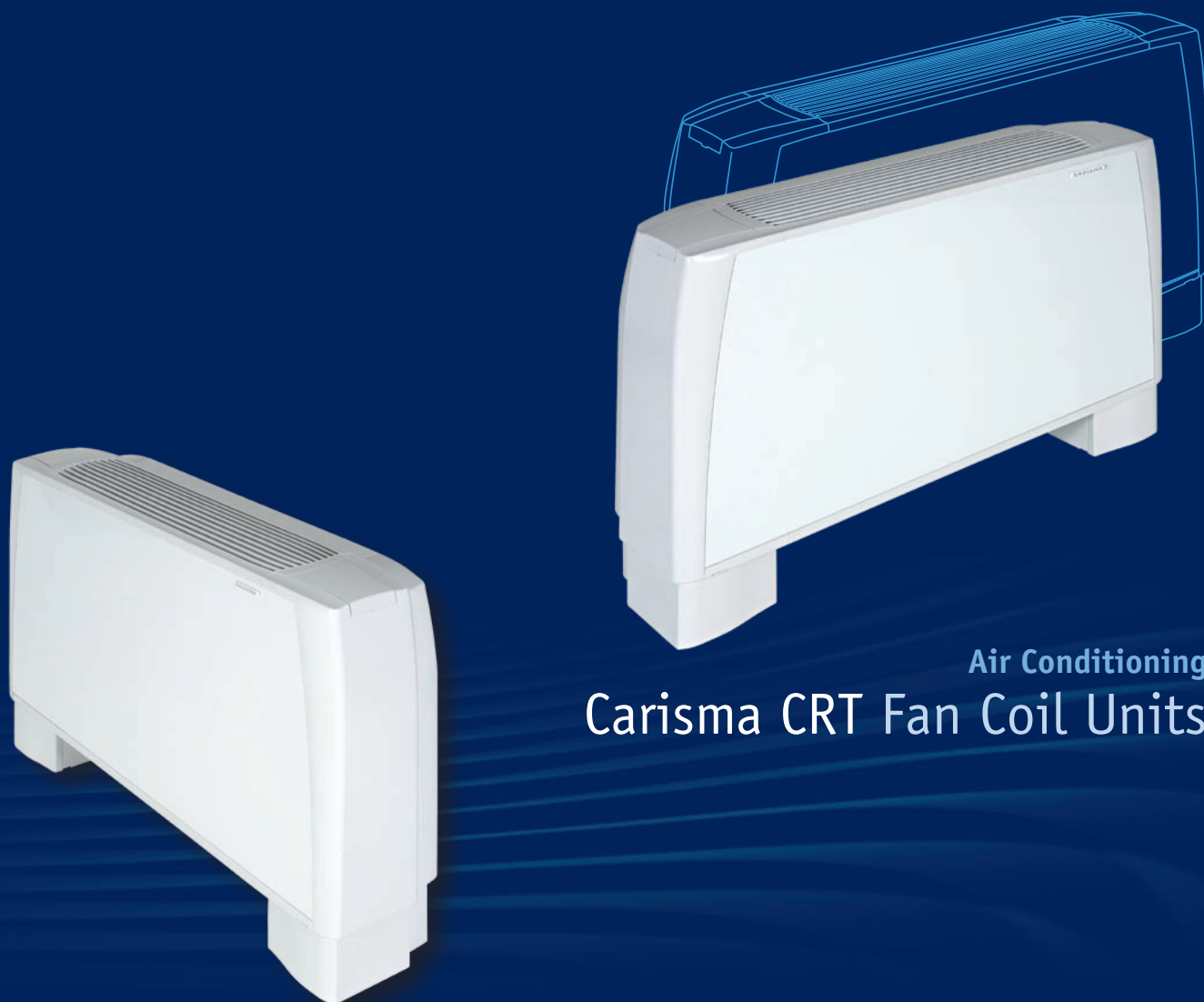

Air Conditioning
Carisma CRT Fan Coil Units



Quality management systems
ISO 9001 – Cert. n° 0545/4



www.eurovent-certification.com
www.certiflash.com



SABIANA
ENVIRONMENTAL COMFORT

Carisma fan coils with **tangential fan** combine a beautiful design with very interesting performances in terms of sound level and energy consumption. **CRT** models are available in five different models, for wall and ceiling installation, with casing and concealed.

Besides all the accessories normally provided with a fan coil plant, the **CRT** range can be adjusted and controlled by an innovative patented wireless system.

All Sabiana fan coils take part to the Eurovent program of fan coil performance certification.

The **CRT** range uses a **6 speed** ventilating unit with extremely reduced electric consumptions and with a consumption-performance ratio that is one of the best in the market.

All the models, included the largest ones, have sound pressure values at **average** speed below 35 dB(A) and at minimum speed below 28 dB(A), on all models (*).

Long laboratory tests have enabled obtaining a very stable and regular functioning in time, also in critical conditions, like in situations where the filter and the battery have not been regularly cleaned.

The motor, with newly conceived bearings, is guaranteed for double the number of hours compared to the previous range and stays at a particularly low functioning temperature, even after many days of continuous functioning.

(*) = The sound pressure levels are 9 dB(A) lower than the sound power levels and apply to the reverberant field of a 100m³ room and a reverberation time of 0.5 sec.

CONTENTS

• Construction	Page 4
• Models	Page 5
• Dimensions, Weight, Water content	Page 6
• EUROVENT Certification	Page 10
• Operation limits	Page 12
• Emission tables	Page 13
• Water pressure drop	Page 21
• Accessories	Page 22
• Controls	Page 28
• FreeSabiana wireless control system	Page 36
• Units with IRC electronic board	Page 38
• Maxinet management system for a network of CRT units	Page 42

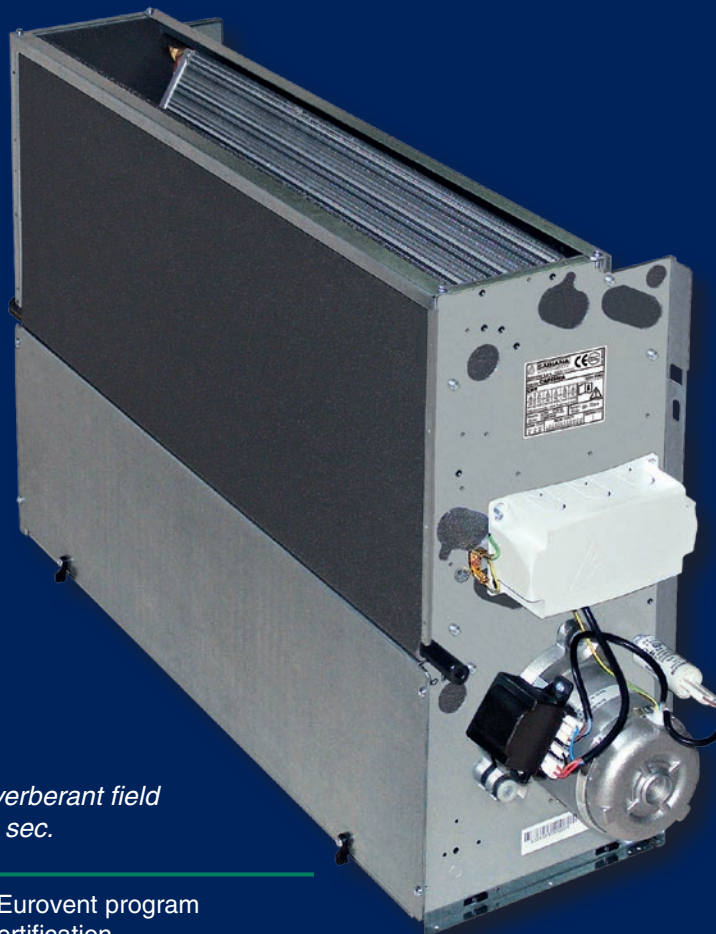

Sabiana take part to the Eurovent program of fan coil performance certification.

The official figures are published in the web site

www.eurovent-certification.com and in the web site www.certiflash.com.

The tested performances are:

- | | |
|--|---|
| <ul style="list-style-type: none"> • Cooling total emission at the following conditions: <ul style="list-style-type: none"> - Water temperature +7°C E.W.T. +12°C L.W.T. - Entering air temperature +27°C dry bulb +19°C wet bulb • Heating emission (2 pipe units) at the following conditions: <ul style="list-style-type: none"> - Entering water temperature +50°C - Entering air temperature +20°C - Water flow rate as for the cooling conditions | <ul style="list-style-type: none"> • Cooling sensible emission at the following conditions: <ul style="list-style-type: none"> - Water temperature +7°C E.W.T. +12°C L.W.T. - Entering air temperature +27°C dry bulb +19°C wet bulb • Heating emission (4 pipe units) at the following conditions: <ul style="list-style-type: none"> - Water temperature +70°C E.W.T. +60°C L.W.T. - Entering air temperature +20°C |
|--|---|

• Fan absorption

• Water pressure drop

• Sound power

CRT version with tangential fan

Range includes 6 air flow rates (from 90 to 945 m³/h) and 5 models (for wall and ceiling installation, with casing and concealed), each equipped with 3 row coil and with the possibility to add a 1 row coil for 4 pipe systems.

It is the most comprehensive range, perfect to meet all air-conditioning requirements of work environments like offices, shops, restaurants and hotel rooms.

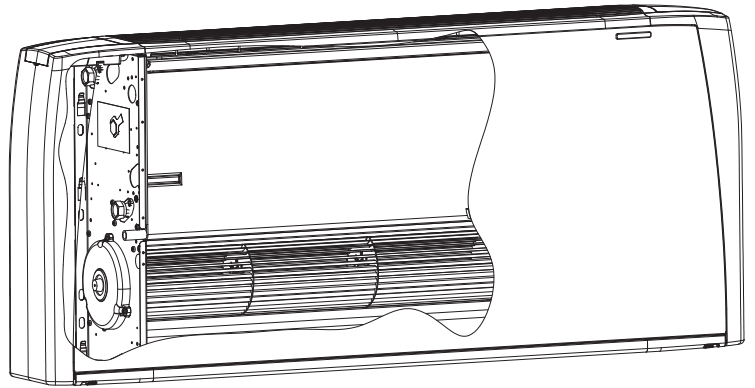

**PLASTIC
OUTLET GRID
IN ONE SINGLE PIECE:
EXTRAORDINARY
DESIGN
AND STRENGTH**

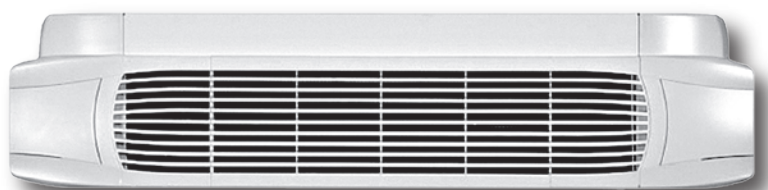

Construction

Outer casing

Made from strong synthetic lateral corners and from galvanized and prepainted frontal steel sheet. The plastic top grid has fixed louvres and is reversible in order to distribute the air in two different directions.

Standard colours:

- Lateral corners and top grid: **Pantone Cool Grey 1C (light grey)**
- Frontal sheet: **RAL 9003 (white)**
- Other colours on request.

Inner casing

Made from galvanized steel with closed cell insulation.

Filter

Polypropylene cellular fabric regenerating filter.

The filter frame of galvanized steel is inserted into special plastic sliding guides fastened to the internal structure for easy insertion and removal of the filter.

Filter presence is highlighted by a plastic front cover featuring the same colour as the top grid.

Fan assembly

The tangential fan assembly is composed of two fan shrouds: an external one in ABS and an internal one of holed, shaped steel. The fan has an external diameter of 120mm and is the length of the coil. The fins are concave and are positioned in a spiral shape along the whole length of the fan.

Electric motor

The motor is wired for single phase and has six speeds, three of which are connected, with capacitor.

The motor is fitted on sealed for life bearings and is secured on anti-vibration and self-lubricating mountings.

Internal thermal protection with automatic reset, protection IP 20, class B.

The speeds connected in the factory are indicated by "MIN, MED and MAX" in the following tables.

Coil

It is manufactured from drawn copper tube and the aluminium fins are mechanically bonded onto the tube by an expansion process. The coil has two 1/2inch BSP internal connections and 1/8 inch BSP air vent and drain.

The coil is not suitable for use in corrosive atmosphere or in environments where aluminium may be subject to corrosion.

Flow and return pipe connections are situated at the same end on the left side looking at the unit. On request we can deliver the unit with the connections on the right end side: this must be specified on the order as this operation can not be carried out on site during installation.

Condensate collection tray

Made from plastic with an "L"-shape fitted on the inner casing. The outside diameter of the condensate discharge pipe is 15mm.

Accessories and Controls

See page 22 and 28.

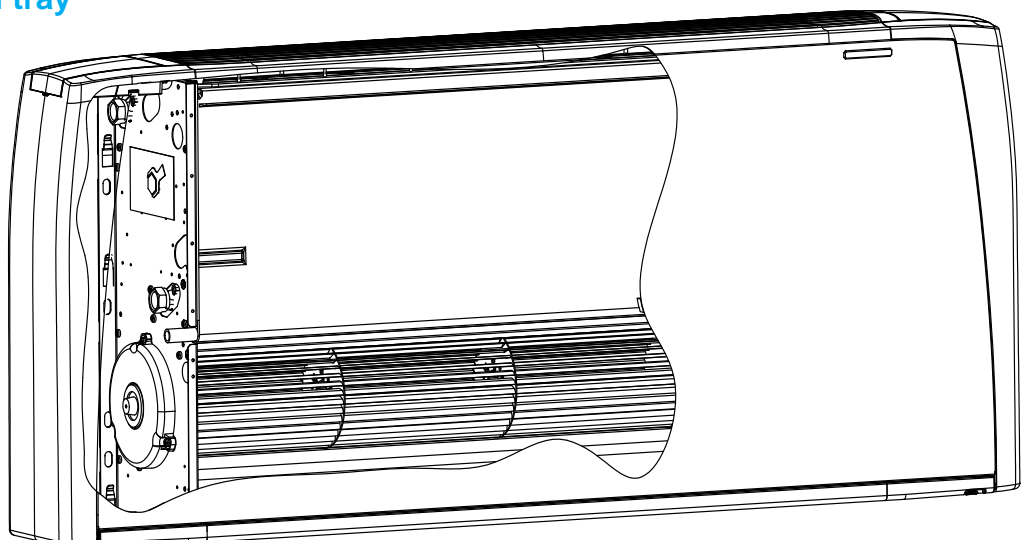

Models

MV

Vertical Casing – Wall Installation

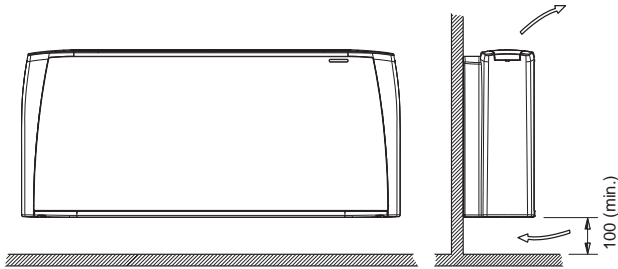

MV

Vertical Casing – Ceiling Installation

NOTE: the MV model can also be installed horizontally leaving behind a 100 mm gap for air intake.

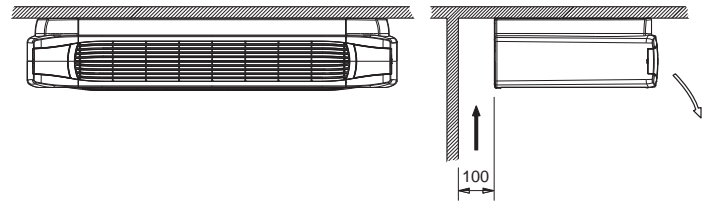

MO-MVB

Vertical Casing – Floor Installation

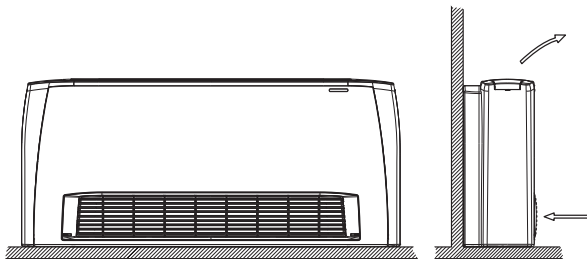

MO-MVB

Horizontal Casing

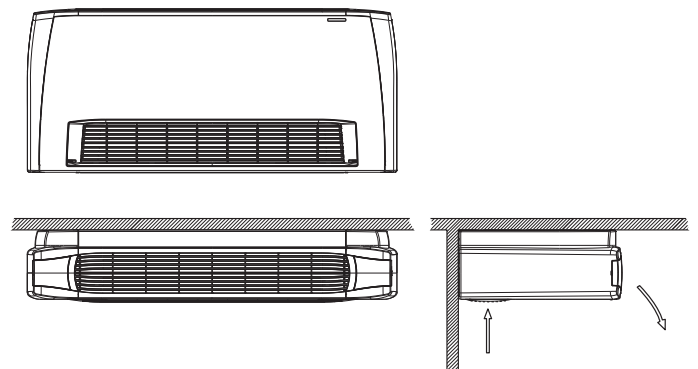

IV-IO

Vertical Concealed

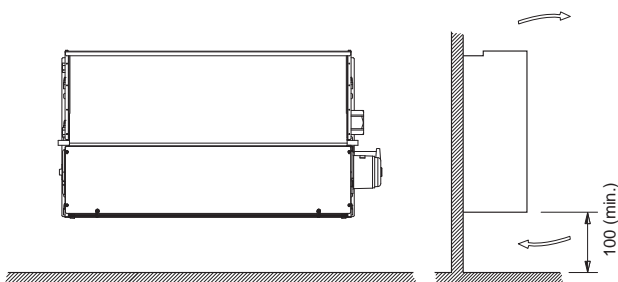

IV-IO

Horizontal Concealed

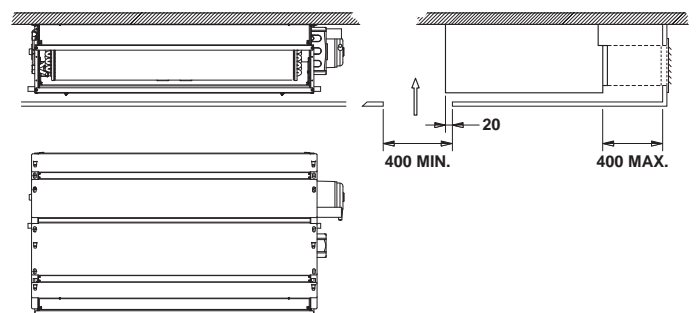

For best operation of **CRT IV-IO** units don't connect any duct on the return side and respect the minimum suggested dimension of the air intake grid.

Dimensions, Weight, Water content

MV

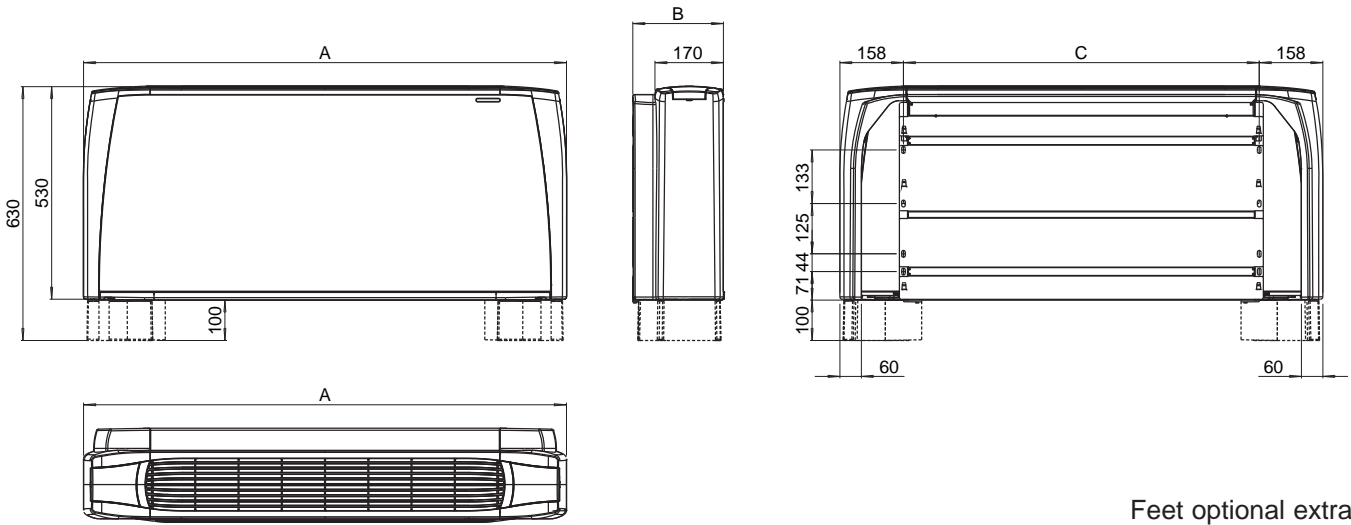

Feet optional extra

MO-MVB

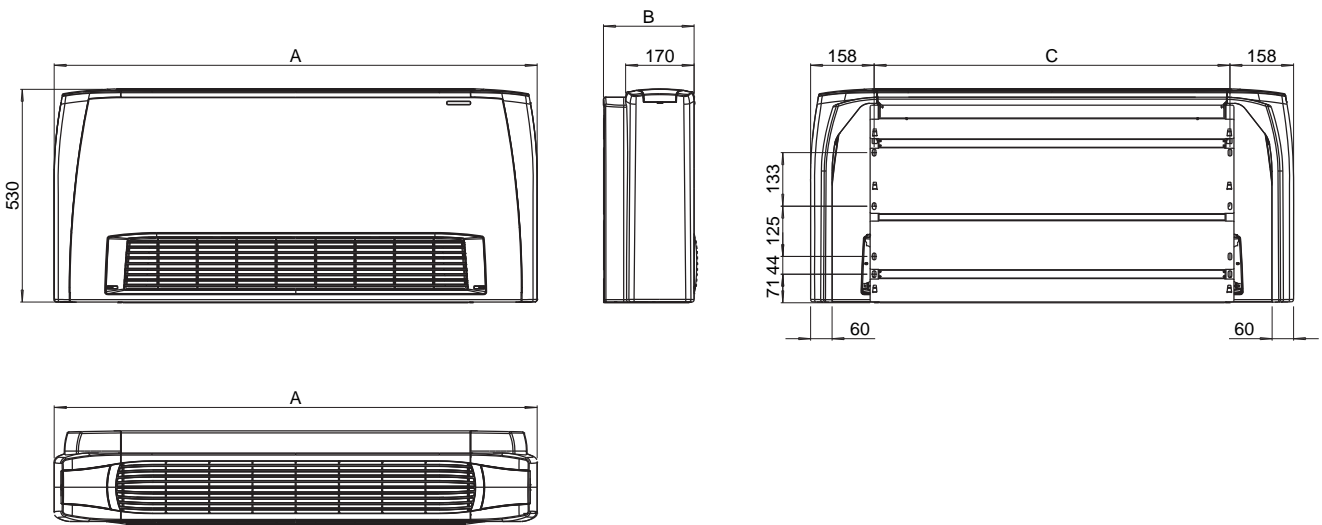

COIL CONNECTIONS

3 row coil

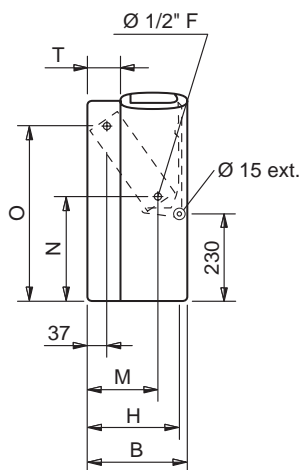

Heating additional coil (1 row)

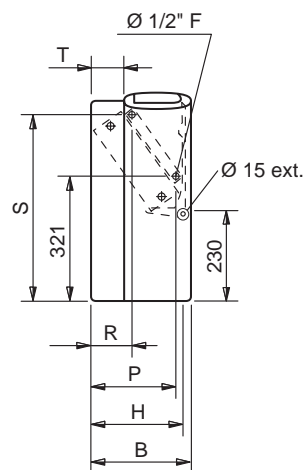

Dimensions, Weight, Water content

PACKAGING

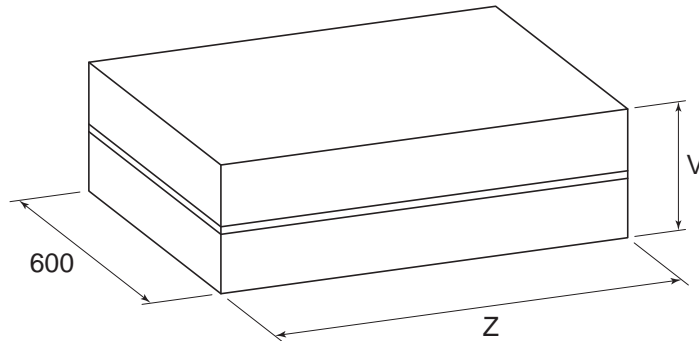

Dimensions (mm)

MODEL	1	2	3	5	6	7
A	670	770	985	1200	1200	1415
B	225	225	225	225	225	225
C	354	454	669	884	884	1099
H	205	205	205	205	205	205
M	145	145	145	145	145	145
N	260	260	260	260	260	260
O	460	460	460	460	460	460
P	185	185	185	185	185	185
R	105	105	105	105	105	105
S	475	475	475	475	475	475
T	55	55	55	55	55	55
V	260	260	260	260	260	260
Z	720	820	1035	1250	1250	1465

Weight (kg)

		Weight with packaging					Weight without packaging						
MODEL		1	2	3	5	6	7	1	2	3	5	6	7
Rows	3	14	16	21	24	25	30	13	14	18	21	22	26
	3+1	15	19	27	30	31	37	14	17	24	27	28	33

Water content (litres)

MODEL	1	2	3	5	6	7	
Rows	3	0,5	0,6	0,9	1,3	1,6	1,7
	3+1	0,2	0,2	0,3	0,4	0,5	0,5

Dimensions, Weight, Water content

IV-IO Vertical Installation

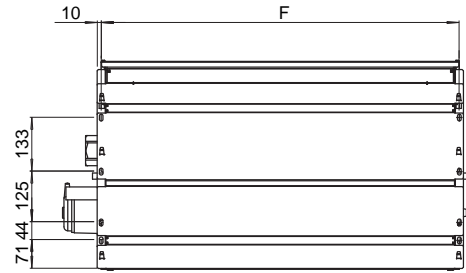
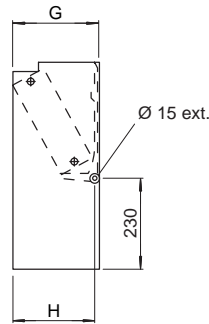
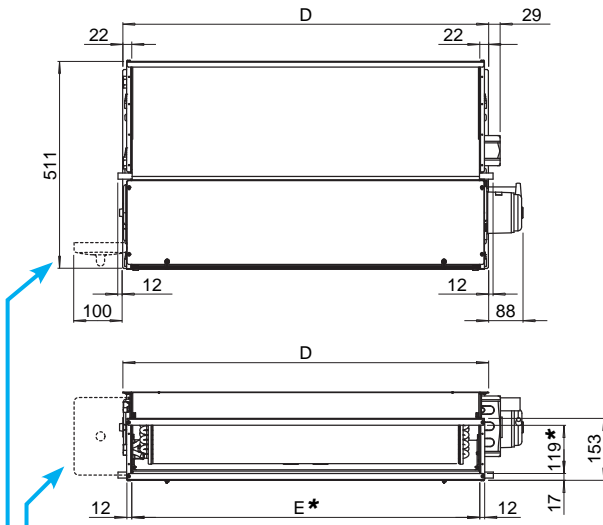

* Supply frame dimension = E x 119 mm

Condensate tray (optional)

IV-IO Horizontal Installation

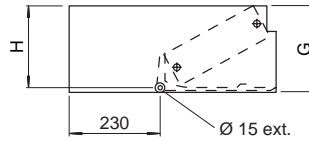
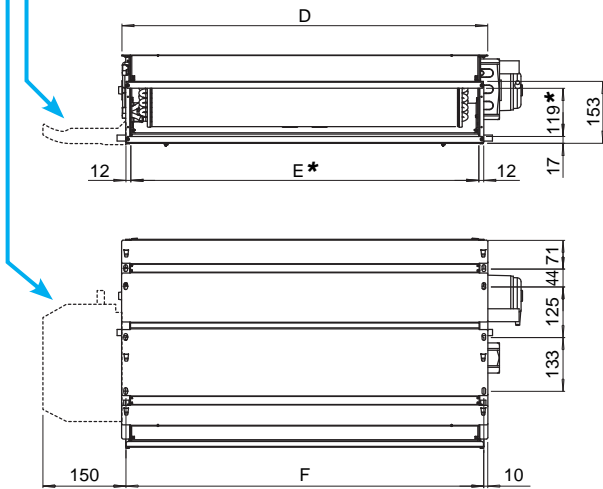

* Supply frame dimension = E x 119 mm

COIL CONNECTIONS

3 row coil

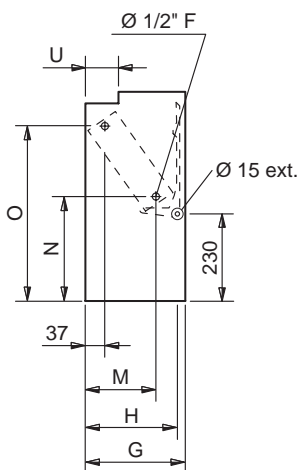

Heating additional coil (1 row)

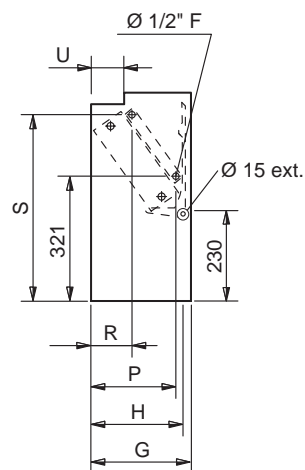

Dimensions, Weight, Water content

PACKAGING

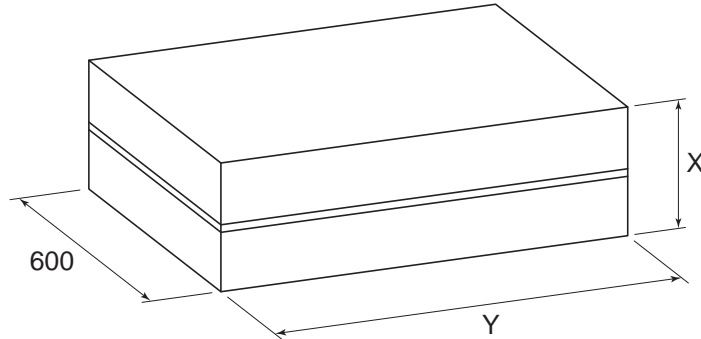

Dimensions (mm)

MODEL	1	2	3	5	6	7
D	374	474	689	904	904	1119
E	330	430	645	860	860	1075
F	354	454	669	884	884	1099
G	218	218	218	218	218	218
H	205	205	205	205	205	205
M	145	145	145	145	145	145
N	260	260	260	260	260	260
O	460	460	460	460	460	460
P	185	185	185	185	185	185
R	105	105	105	105	105	105
S	475	475	475	475	475	475
U	65	65	65	65	65	65
X	260	260	260	260	260	260
Y	720	820	820	1035	1035	1250

Weight (kg)

		Weight with packaging					Weight without packaging						
MODEL		1	2	3	5	6	7	1	2	3	5	6	7
Rows	3	10	15	19	22	23	27	9	13	18	21	22	25
	3+1	11	17	25	28	29	34	10	16	23	26	27	31

Water content (litres)

MODEL	1	2	3	5	6	7	
Rows	3	0,5	0,6	0,9	1,3	1,6	1,7
	3+1	0,2	0,2	0,3	0,4	0,5	0,5

CRT UNITS WITH 3 ROW COIL

2 pipe units.

The following standard rating conditions are used:

COOLING

Entering air temperature +27°C d.b. +19°C w.b.
Water temperature +7°C E.W.T. +12°C L.W.T.

HEATING

Entering air temperature +20°C
Entering water temperature +50°C
Water flow rate as for the cooling conditions

MODEL		CRT 13						CRT 23						CRT 33					
		1	2 (E)	3 (E)	4	5 (E)	6	1	2 (E)	3 (E)	4	5 (E)	6	1	2 (E)	3 (E)	4	5 (E)	6
			MIN	MED		MAX			MIN	MED		MAX			MIN	MED		MAX	
Speed																			
Air flow	m ³ /h	95	115	140	175	200	240	125	150	180	225	250	305	170	205	275	315	370	440
Cooling total emission (E)	kW	0,51	0,59	0,69	0,79	0,87	0,99	0,73	0,85	0,96	1,14	1,24	1,41	1,09	1,29	1,63	1,83	2,04	2,36
Cooling sensible emission (E)	kW	0,40	0,48	0,56	0,66	0,74	0,86	0,56	0,66	0,75	0,91	0,99	1,15	0,81	0,96	1,23	1,39	1,56	1,83
Heating (E)	kW	0,68	0,80	0,94	1,11	1,24	1,44	0,94	1,11	1,27	1,53	1,66	1,93	1,32	1,57	2,02	2,27	2,55	2,99
Dp Cooling (E)	kPa	0,7	0,9	1,2	1,5	1,8	2,2	1,6	2,1	2,6	3,6	4,1	5,2	5,0	6,7	10,1	12,3	15,2	20,0
Dp Heating (E)	kPa	0,5	0,7	0,9	1,2	1,5	1,9	1,3	1,8	2,2	3,0	3,3	4,3	4,1	5,3	8,3	10,2	12,5	15,6
Fan (E)	W	6	8	11	14	17	23	7	9	12	16	19	25	8	10	15	18	23	31
Sound power (E)	Lw dB(A)	27	31	36	41	44	47	26	31	35	40	43	47	28	31	36	40	44	48
Sound pressure (*)	Lp dB(A)	18	22	27	32	35	38	17	22	26	31	34	38	19	22	27	31	35	39

MODEL		CRT 53						CRT 63						CRT 73					
		1	2 (E)	3 (E)	4	5 (E)	6	1	2 (E)	3 (E)	4	5 (E)	6	1	2 (E)	3 (E)	4	5 (E)	6
			MIN	MED		MAX			MIN	MED		MAX			MIN	MED		MAX	
Speed																			
Air flow	m ³ /h	225	285	360	440	495	610	305	370	475	560	635	780	360	445	570	680	780	945
Cooling total emission (E)	kW	1,46	1,77	2,17	2,53	2,76	3,23	1,88	2,19	2,67	3,02	3,33	3,87	2,29	2,72	3,32	3,77	4,18	4,82
Cooling sensible emission (E)	kW	1,08	1,32	1,64	1,93	2,12	2,52	1,41	1,66	2,05	2,34	2,61	3,07	1,70	2,04	2,52	2,89	3,23	3,78
Heating (E)	kW	1,77	2,17	2,69	3,16	3,47	4,13	2,31	2,73	3,34	3,83	4,26	5,03	2,78	3,33	4,10	4,71	5,27	6,16
Dp Cooling (E)	kPa	3,3	4,6	6,5	8,5	9,9	13,1	5,1	6,6	9,4	11,6	13,8	18,0	8,5	11,5	16,6	20,9	25,1	31,7
Dp Heating (E)	kPa	2,7	3,7	5,4	7,0	8,1	11,0	4,1	5,5	7,6	9,7	11,4	15,2	7,0	9,1	13,1	16,2	19,8	25,2
Fan (E)	W	12	15	22	27	33	46	15	20	28	35	44	60	19	24	34	43	53	72
Sound power (E)	Lw dB(A)	26	31	37	41	43	48	31	36	43	47	50	54	32	36	43	47	50	55
Sound pressure (*)	Lp dB(A)	17	22	28	32	34	39	22	27	34	38	41	45	23	27	34	38	41	46

(E) = Eurovent certified performance. MIN-MED-MAX = Standard connected speeds.

(*) = The sound pressure levels are 9 dB(A) lower than the sound power levels and apply to the reverberant field of a 100 m³ room and a reverberation time of 0.5 sec.

CRT UNITS WITH 1 ROW ADDITIONAL COIL

4 pipe units.

The following standard rating conditions are used:

COOLING

Entering air temperature +27°C d.b. +19°C w.b.
Water temperature + 7°C E.W.T. +12°C L.W.T.

HEATING

Entering air temperature +20°C
Water temperature +70°C E.W.T. +60°C L.W.T.

MODEL		CRT 13+1						CRT 23+1						CRT 33+1								
		1	2 (E)	3 (E)	4	5 (E)	6	1	2 (E)	3 (E)	4	5 (E)	6	1	2 (E)	3 (E)	4	5 (E)	6			
Speed			MIN	MED		MAX		MIN	MED		MAX		MIN	MED		MAX		MIN	MED		MAX	
Air flow	m³/h	90	110	135	165	190	225	115	140	170	210	240	290	165	200	255	300	345	415			
Cooling total emission (E)	kW	0,49	0,57	0,67	0,76	0,84	0,95	0,68	0,80	0,92	1,08	1,20	1,36	1,05	1,25	1,54	1,73	1,94	2,22			
Cooling sensible emission (E)	kW	0,38	0,46	0,55	0,63	0,71	0,81	0,52	0,62	0,71	0,86	0,96	1,11	0,78	0,93	1,16	1,32	1,49	1,73			
Heating (E)	kW	0,60	0,69	0,80	0,91	1,01	1,13	0,82	0,95	1,07	1,25	1,38	1,56	1,25	1,45	1,74	1,93	2,14	2,43			
Dp Cooling (E)	kPa	0,6	0,8	1,1	1,4	1,6	2,0	1,4	1,9	2,4	3,3	3,9	4,9	4,5	6,1	8,8	10,8	13,2	16,8			
Dp Heating (E)	kPa	0,6	0,8	1,0	1,3	1,5	1,9	1,3	1,6	2,0	2,6	3,1	3,9	3,4	4,4	6,1	7,3	8,8	11,0			
Fan (E)	W	6	8	11	14	17	23	7	9	12	16	19	25	8	10	15	18	23	31			
Sound power (E)	Lw dB(A)	27	31	36	41	44	47	26	31	35	40	43	47	28	31	36	40	44	48			
Sound pressure (*)	Lp dB(A)	18	22	27	32	35	38	17	22	26	31	34	38	19	22	27	31	35	39			

MODEL		CRT 53+1						CRT 63+1						CRT 73+1								
		1	2 (E)	3 (E)	4	5 (E)	6	1	2 (E)	3 (E)	4	5 (E)	6	1	2 (E)	3 (E)	4	5 (E)	6			
Speed			MIN	MED		MAX		MIN	MED		MAX		MIN	MED		MAX		MIN	MED		MAX	
Air flow	m³/h	215	275	345	420	475	580	285	345	440	520	600	735	345	420	540	640	735	895			
Cooling total emission (E)	kW	1,41	1,72	2,09	2,44	2,67	3,11	1,77	2,09	2,53	2,87	3,19	3,70	2,21	2,59	3,17	3,62	4,04	4,63			
Cooling sensible emission (E)	kW	1,04	1,28	1,57	1,85	2,05	2,41	1,32	1,57	1,93	2,21	2,48	2,93	1,64	1,93	2,40	2,76	3,11	3,61			
Heating (E)	kW	1,64	1,95	2,31	2,65	2,87	3,30	2,00	2,31	2,74	3,07	3,39	3,90	2,52	2,89	3,46	3,90	4,31	4,91			
Dp Cooling (E)	kPa	3,0	4,3	6,1	8,0	9,4	12,2	4,6	6,1	8,5	10,6	12,8	16,6	7,8	10,3	14,8	18,6	22,6	28,7			
Dp Heating (E)	kPa	1,1	1,5	2,0	2,5	2,9	3,7	1,5	2,0	2,7	3,2	3,9	4,9	2,7	3,4	4,7	5,8	6,9	8,7			
Fan (E)	W	12	15	21	27	33	46	15	20	28	35	44	60	19	24	34	43	53	72			
Sound power (E)	Lw dB(A)	26	31	37	41	43	48	31	36	43	47	50	54	32	36	43	47	50	55			
Sound pressure (*)	Lp dB(A)	17	22	28	32	34	39	22	27	34	38	41	45	23	27	34	38	41	46			

(E) = Eurovent certified performance.

MIN-MED-MAX = Standard connected speeds.

(*) = The sound pressure levels are 9 dB(A) lower than the sound power levels and apply to the reverberant field of a 100 m³ room and a reverberation time of 0.5 sec.

Operation limits

Highest water inlet temperature.....+ 85 °C
 Lowest water inlet temperature.....+ 5 °C
*for entering water temperatures below + 5°C,
 contact "SABIANA" technical department*
 Highest working pressure..... 1000 kPa (10 bars)

Note: For MO model the maximum installation height is 2,8 m.
 On heating it must be payed attention to rooms where the floor temperature is particularly low (for example less than 5°C).
 In this situation the floor can cool the lower layer of air to a level that can stop the uniform diffusion of the hot air coming from the unit.

Water flow limits for 3 row coil (l/h)

MODEL	CRT 13	CRT 23	CRT 33	CRT 53	CRT 63	CRT 73
Lowest	100	100	100	150	150	150
Highest	400	500	750	1000	1000	1500

Water flow limits for 1 row additional coil (l/h)

MODEL	CRT 13+1	CRT 23+1	CRT 33+1	CRT 53+1	CRT 63+1	CRT 73+1
Lowest	50	50	50	100	100	100
Highest	200	250	350	450	500	650

Motor electrical data (max. absorption)

MODEL		CRT 1	CRT 2	CRT 3	CRT 5	CRT 6	CRT 7
230/1 50Hz	W	23	25	31	46	60	72
	A	0,099	0,113	0,150	0,202	0,263	0,317

Cooling emission of 3 row coil

Entering air temperature: 27°C – R.H.: 50%

MODEL	Speed		WT: 7/12 °C					WT: 8/13 °C					WT: 10/15 °C					WT: 12/17 °C				
			Qv	Pc	Ps	Qw	Dp(c)	Pc	Ps	Qw	Dp(c)	Pc	Ps	Qw	Dp(c)	Pc	Ps	Qw	Dp(c)			
			m³/h	kW	kW	l/h	kPa	kW	kW	l/h	kPa	kW	kW	l/h	kPa	kW	kW	l/h	kPa			
CRT 13	VI		240	1,08	0,85	186	2,5	0,95	0,80	163	2,0	0,71	0,71	122	1,2	0,60	0,60	103	0,9			
	V	MAX	200	0,95	0,73	163	2,0	0,83	0,69	143	1,6	0,62	0,62	107	0,9	0,52	0,52	89	0,7			
	IV		175	0,86	0,66	148	1,7	0,76	0,62	131	1,4	0,54	0,54	93	0,8	0,47	0,47	81	0,6			
	III	MED	140	0,75	0,56	129	1,3	0,66	0,53	114	1,1	0,48	0,46	83	0,6	0,40	0,40	69	0,4			
	II	MIN	115	0,64	0,47	110	1,0	0,57	0,44	98	0,8	0,41	0,39	71	0,5	0,34	0,34	58	0,3			
	I		95	0,55	0,40	95	0,8	0,49	0,38	84	0,6	0,36	0,33	62	0,4	0,29	0,29	50	0,2			
CRT 23	VI		305	1,53	1,15	263	6,0	1,36	1,08	234	4,8	0,99	0,94	170	2,7	0,82	0,82	141	1,9			
	V	MAX	250	1,34	0,99	230	4,7	1,19	0,93	205	3,8	0,88	0,81	151	2,2	0,71	0,71	122	1,5			
	IV		225	1,23	0,91	212	4,1	1,10	0,85	189	3,3	0,81	0,74	139	1,9	0,65	0,65	112	1,3			
	III	MED	180	1,04	0,75	179	3,0	0,92	0,70	158	2,4	0,69	0,61	119	1,4	0,54	0,54	93	0,9			
	II	MIN	150	0,92	0,66	158	2,4	0,82	0,62	141	2,0	0,61	0,54	105	1,2	0,47	0,47	81	0,7			
	I		125	0,79	0,56	136	1,9	0,71	0,53	122	1,5	0,53	0,46	91	0,9	0,40	0,40	69	0,6			
CRT 33	VI		440	2,54	1,82	437	22,0	2,28	1,72	392	18,0	1,72	1,50	296	10,9	1,32	1,32	227	6,7			
	V	MAX	370	2,19	1,55	377	17,0	1,97	1,46	339	13,9	1,49	1,28	256	8,5	1,12	1,12	193	5,1			
	IV		315	1,97	1,38	339	14,0	1,77	1,30	304	11,5	1,34	1,14	230	7,0	1,00	1,00	172	4,1			
	III	MED	275	1,75	1,23	301	11,5	1,58	1,15	272	9,4	1,20	1,01	206	5,8	0,89	0,89	153	3,4			
	II	MIN	205	1,39	0,96	239	7,6	1,25	0,90	215	6,3	0,95	0,78	163	3,9	0,69	0,69	119	2,2			
	I		170	1,17	0,81	201	5,7	1,06	0,76	182	4,7	0,81	0,66	139	2,9	0,58	0,58	100	1,6			
CRT 53	VI		610	3,48	2,51	599	14,9	3,12	2,36	537	12,2	2,35	2,06	404	7,3	1,81	1,81	311	4,6			
	V	MAX	495	2,97	2,11	511	11,3	2,66	1,99	458	9,3	2,02	1,74	347	5,6	1,53	1,53	263	3,4			
	IV		440	2,72	1,92	468	9,7	2,44	1,81	420	8,0	1,85	1,58	318	4,8	1,39	1,39	239	2,9			
	III	MED	360	2,33	1,63	401	7,4	2,09	1,53	359	6,1	1,59	1,34	273	3,7	1,18	1,18	203	2,2			
	II	MIN	285	1,91	1,32	329	5,2	1,71	1,24	294	4,3	1,31	1,08	225	2,6	0,95	0,95	163	1,5			
	I		225	1,57	1,08	270	3,7	1,42	1,02	244	3,0	1,09	0,88	187	1,9	0,78	0,78	134	1,0			
CRT 63	VI		780	4,16	3,05	716	20,5	3,72	2,88	640	16,7	2,79	2,52	480	9,9	2,21	2,21	380	6,5			
	V	MAX	635	3,59	2,59	617	15,8	3,21	2,44	552	12,9	2,42	2,13	416	7,7	1,87	1,87	322	4,9			
	IV		560	3,25	2,33	559	13,3	2,91	2,19	501	10,9	2,20	1,92	378	6,5	1,68	1,68	289	4,0			
	III	MED	475	2,87	2,04	494	10,6	2,58	1,92	444	8,7	1,95	1,67	335	5,3	1,47	1,47	253	3,2			
	II	MIN	370	2,36	1,65	406	7,5	2,12	1,55	365	6,2	1,61	1,35	277	3,8	1,20	1,20	206	2,2			
	I		305	2,02	1,41	347	5,7	1,82	1,32	313	4,7	1,39	1,15	239	2,9	1,02	1,02	175	1,7			
CRT 73	VI		945	5,19	3,76	893	35,1	4,65	3,54	800	28,7	3,52	3,11	605	17,3	2,73	2,73	470	11,0			
	V	MAX	780	4,50	3,22	774	27,3	4,04	3,03	695	22,4	3,07	2,65	528	13,6	2,33	2,33	401	8,3			
	IV		680	4,06	2,88	698	22,8	3,65	2,71	628	18,7	2,77	2,37	476	11,4	2,09	2,09	359	6,8			
	III	MED	570	3,56	2,51	612	18,1	3,20	2,36	550	14,9	2,44	2,06	420	9,1	1,81	1,81	311	5,3			
	II	MIN	445	2,92	2,03	502	12,8	2,63	1,91	452	10,6	2,01	1,67	346	6,5	1,48	1,48	255	3,7			
	I		360	2,46	1,70	423	9,5	2,22	1,60	382	7,8	1,70	1,39	292	4,8	1,23	1,23	212	2,7			

Correction factors for different R.H.

R.H.	WT:	7/12°C	8/13°C	10/15°C	12/17°C
48%	Pc	0,95	0,94	1,00	1,00
	Ps	1,00	1,00	1,00	1,00
46%	Pc	0,90	0,88	1,00	1,00
	Ps	1,00	1,00	1,00	1,00

LEGEND

- WT = Water temperature
- Pc = Cooling total emission
- Ps = Cooling sensible emission
- Qw = Water flow
- Dp(c) = Water pressure drop
- Speed = Fan speed
- MAX = High speed
- MED = Medium speed
- MIN = Low speed
- Qv = Air flow

Cooling emission of 3 row coil

Entering air temperature: 26°C – R.H.: 50%

MODEL	Speed	WT: 7/12 °C						WT: 8/13 °C				WT: 10/15 °C				WT: 12/17 °C			
		Qv	Pc	Ps	Qw	Dp(c)	Pc	Ps	Qw	Dp(c)	Pc	Ps	Qw	Dp(c)	Pc	Ps	Qw	Dp(c)	
		m³/h	kW	kW	l/h	kPa	kW	kW	l/h	kPa	kW	kW	l/h	kPa	kW	kW	l/h	kPa	
CRT 13	VI	240	0,94	0,80	162	2,0	0,81	0,75	139	1,5	0,65	0,65	112	1,0	0,54	0,54	93	0,7	
	V MAX	200	0,83	0,69	143	1,6	0,72	0,65	124	1,2	0,57	0,57	98	0,8	0,47	0,47	81	0,6	
	IV	175	0,76	0,62	131	1,4	0,65	0,58	112	1,1	0,51	0,51	88	0,7	0,42	0,42	72	0,5	
	III MED	140	0,66	0,53	114	1,1	0,57	0,49	98	0,8	0,43	0,43	74	0,5	0,36	0,36	62	0,4	
	II MIN	115	0,56	0,45	96	0,8	0,49	0,42	84	0,6	0,37	0,37	64	0,4	0,31	0,31	53	0,3	
	I	95	0,49	0,38	84	0,6	0,42	0,35	72	0,5	0,31	0,31	53	0,3	0,26	0,26	45	0,2	
CRT 23	VI	305	1,35	1,08	232	4,8	1,18	1,01	203	3,8	0,90	0,90	155	2,3	0,75	0,75	129	1,6	
	V MAX	250	1,18	0,93	203	3,8	1,04	0,87	179	3,0	0,77	0,77	132	1,8	0,65	0,65	112	1,3	
	IV	225	1,09	0,85	187	3,3	0,96	0,80	165	2,6	0,71	0,71	122	1,5	0,59	0,59	101	1,1	
	III MED	180	0,92	0,70	158	2,4	0,81	0,66	139	1,9	0,59	0,59	101	1,1	0,49	0,49	84	0,8	
	II MIN	150	0,81	0,62	139	2,0	0,71	0,58	122	1,6	0,50	0,49	86	0,8	0,43	0,43	74	0,6	
	I	125	0,70	0,53	120	1,5	0,62	0,49	107	1,2	0,44	0,42	76	0,6	0,37	0,37	64	0,5	
CRT 33	VI	440	2,27	1,72	390	18,0	2,00	1,61	344	14,4	1,43	1,39	246	7,9	1,21	1,21	208	5,7	
	V MAX	370	1,96	1,47	337	13,9	1,73	1,37	298	11,1	1,24	1,18	213	6,1	1,03	1,03	177	4,3	
	IV	315	1,76	1,31	303	11,5	1,55	1,22	267	9,2	1,12	1,05	193	5,1	0,91	0,91	157	3,5	
	III MED	275	1,57	1,16	270	9,4	1,39	1,08	239	7,6	1,01	0,93	174	4,2	0,82	0,82	141	2,9	
	II MIN	205	1,24	0,90	213	6,2	1,10	0,85	189	5,0	0,80	0,73	138	2,8	0,63	0,63	108	1,9	
	I	170	1,05	0,76	181	4,6	0,93	0,71	160	3,7	0,68	0,61	117	2,1	0,53	0,53	91	1,4	
CRT 53	VI	610	3,10	2,36	533	12,2	2,74	2,21	471	9,7	1,95	1,91	335	5,3	1,66	1,66	286	3,9	
	V MAX	495	2,65	1,99	456	9,2	2,34	1,87	402	7,4	1,68	1,61	289	4,1	1,40	1,40	241	2,9	
	IV	440	2,43	1,81	418	7,9	2,15	1,70	370	6,3	1,54	1,46	265	3,5	1,27	1,27	218	2,4	
	III MED	360	2,08	1,54	358	6,0	1,84	1,44	316	4,8	1,33	1,24	229	2,7	1,08	1,08	186	1,9	
	II MIN	285	1,70	1,25	292	4,2	1,51	1,16	260	3,4	1,10	1,00	189	1,9	0,87	0,87	150	1,3	
	I	225	1,41	1,02	243	3,0	1,25	0,95	215	2,4	0,91	0,82	157	1,4	0,71	0,71	122	0,9	
CRT 63	VI	780	3,71	2,88	638	16,7	3,27	2,70	562	13,3	2,41	2,41	415	7,6	2,02	2,02	347	5,5	
	V MAX	635	3,20	2,44	550	12,9	2,82	2,29	485	10,2	2,01	1,98	346	5,6	1,71	1,71	294	4,1	
	IV	560	2,90	2,20	499	10,8	2,56	2,06	440	8,6	1,83	1,77	315	4,7	1,54	1,54	265	3,4	
	III MED	475	2,56	1,92	440	8,7	2,26	1,80	389	7,0	1,63	1,55	280	3,8	1,35	1,35	232	2,7	
	II MIN	370	2,10	1,56	361	6,2	1,86	1,46	320	4,9	1,35	1,25	232	2,7	1,10	1,10	189	1,9	
	I	305	1,81	1,32	311	4,7	1,60	1,24	275	3,8	1,16	1,07	200	2,1	0,93	0,93	160	1,4	
CRT 73	VI	945	4,63	3,55	796	28,7	4,09	3,33	703	22,9	2,93	2,88	504	12,6	2,50	2,50	430	9,4	
	V MAX	780	4,02	3,04	691	22,4	3,55	2,85	611	17,9	2,56	2,46	440	9,9	2,13	2,13	366	7,1	
	IV	680	3,63	2,72	624	18,7	3,21	2,55	552	15,0	2,32	2,20	399	8,3	1,91	1,91	329	5,8	
	III MED	570	3,19	2,36	549	14,9	2,82	2,21	485	11,9	2,05	1,91	353	6,7	1,66	1,66	286	4,6	
	II MIN	445	2,61	1,92	449	10,5	2,32	1,79	399	8,5	1,69	1,55	291	4,8	1,35	1,35	232	3,2	
	I	360	2,20	1,60	378	7,8	1,96	1,50	337	6,3	1,44	1,29	248	3,6	1,13	1,13	194	2,3	

Correction factors for different R.H.

R.H.	WT:	7/12°C	8/13°C	10/15°C	12/17°C
48%	Pc	0,95	0,94	1,00	1,00
	Ps	1,00	1,00	1,00	1,00
46%	Pc	0,90	0,88	1,00	1,00
	Ps	1,00	1,00	1,00	1,00

LEGEND

- WT = Water temperature
- Pc = Cooling total emission
- Ps = Cooling sensible emission
- Qw = Water flow
- Dp(c) = Water pressure drop
- Speed = Fan speed
- MAX = High speed
- MED = Medium speed
- MIN = Low speed
- Qv = Air flow

Cooling emission of 3 row coil

Entering air temperature: 25°C – R.H.: 50%

MODEL	Speed		WT: 7/12 °C					WT: 8/13 °C					WT: 10/15 °C					WT: 12/17 °C				
			Qv	Pc	Ps	Qw	Dp(c)	Pc	Ps	Qw	Dp(c)	Pc	Ps	Qw	Dp(c)	Pc	Ps	Qw	Dp(c)			
			m³/h	kW	kW	l/h	kPa	kW	kW	l/h	kPa	kW	kW	l/h	kPa	kW	kW	l/h	kPa			
CRT 13	VI		240	0,82	0,75	141	1,6	0,71	0,71	122	1,2	0,60	0,60	103	0,9	0,49	0,49	84	0,6			
	V	MAX	200	0,72	0,65	124	1,3	0,61	0,60	105	0,9	0,52	0,52	89	0,7	0,42	0,42	72	0,5			
	IV		175	0,65	0,58	112	1,1	0,55	0,54	95	0,8	0,46	0,46	79	0,6	0,38	0,38	65	0,4			
	III	MED	140	0,57	0,49	98	0,8	0,48	0,46	83	0,6	0,40	0,40	69	0,4	0,32	0,32	55	0,3			
	II	MIN	115	0,49	0,42	84	0,6	0,42	0,39	72	0,5	0,34	0,34	58	0,3	0,28	0,28	48	0,2			
	I		95	0,42	0,35	72	0,5	0,36	0,33	62	0,4	0,29	0,29	50	0,2	0,24	0,24	41	0,2			
CRT 23	VI		305	1,18	1,01	203	3,8	1,01	0,94	174	2,8	0,82	0,82	141	2,0	0,67	0,67	115	1,4			
	V	MAX	250	1,03	0,87	177	3,0	0,89	0,81	153	2,3	0,71	0,71	122	1,5	0,58	0,58	100	1,1			
	IV		225	0,96	0,80	165	2,6	0,82	0,74	141	2,0	0,65	0,65	112	1,3	0,53	0,53	91	0,9			
	III	MED	180	0,80	0,66	138	1,9	0,69	0,61	119	1,5	0,54	0,54	93	0,9	0,44	0,44	76	0,7			
	II	MIN	150	0,71	0,58	122	1,6	0,61	0,54	105	1,2	0,47	0,47	81	0,7	0,39	0,39	67	0,5			
	I		125	0,62	0,49	107	1,2	0,53	0,46	91	0,9	0,40	0,40	69	0,6	0,33	0,33	57	0,4			
CRT 33	VI		440	2,00	1,62	344	14,4	1,73	1,51	298	11,2	1,32	1,32	227	6,8	1,09	1,09	187	4,8			
	V	MAX	370	1,73	1,38	298	11,1	1,50	1,28	258	8,6	1,13	1,13	194	5,2	0,93	0,93	160	3,6			
	IV		315	1,55	1,23	267	9,2	1,35	1,14	232	7,2	1,00	1,00	172	4,2	0,83	0,83	143	3,0			
	III	MED	275	1,38	1,09	237	7,6	1,21	1,01	208	5,9	0,89	0,89	153	3,4	0,74	0,74	127	2,4			
	II	MIN	205	1,10	0,85	189	5,0	0,96	0,79	165	3,9	0,70	0,70	120	2,2	0,58	0,58	100	1,6			
	I		170	0,93	0,71	160	3,7	0,81	0,66	139	2,9	0,58	0,58	100	1,6	0,48	0,48	83	1,1			
CRT 53	VI		610	2,73	2,22	470	9,7	2,36	2,07	406	7,5	1,82	1,82	313	4,7	1,50	1,50	258	3,3			
	V	MAX	495	2,33	1,87	401	7,4	2,03	1,74	349	5,7	1,53	1,53	263	3,4	1,26	1,26	217	2,4			
	IV		440	2,14	1,70	368	6,4	1,86	1,59	320	4,9	1,39	1,39	239	2,9	1,15	1,15	198	2,1			
	III	MED	360	1,84	1,44	316	4,8	1,60	1,34	275	3,8	1,19	1,19	205	2,2	0,98	0,98	169	1,6			
	II	MIN	285	1,51	1,17	260	3,4	1,31	1,09	225	2,7	0,96	0,96	165	1,5	0,79	0,79	136	1,1			
	I		225	1,24	0,96	213	2,4	1,09	0,89	187	1,9	0,78	0,78	134	1,1	0,65	0,65	112	0,7			
CRT 63	VI		780	3,26	2,71	561	13,3	2,82	2,53	485	10,2	2,22	2,22	382	6,6	1,83	1,83	315	4,6			
	V	MAX	635	2,82	2,30	485	10,3	2,44	2,14	420	7,9	1,88	1,88	323	4,9	1,55	1,55	267	3,5			
	IV		560	2,56	2,06	440	8,7	2,21	1,92	380	6,7	1,69	1,69	291	4,1	1,39	1,39	239	2,9			
	III	MED	475	2,26	1,80	389	7,0	1,96	1,68	337	5,4	1,48	1,48	255	3,2	1,22	1,22	210	2,3			
	II	MIN	370	1,86	1,46	320	4,9	1,61	1,36	277	3,8	1,20	1,20	206	2,3	0,99	0,99	170	1,6			
	I		305	1,60	1,24	275	3,8	1,39	1,16	239	2,9	1,02	1,02	175	1,7	0,84	0,84	144	1,2			
CRT 73	VI		945	4,08	3,34	702	23,0	3,54	3,12	609	17,8	2,74	2,74	471	11,1	2,26	2,26	389	7,9			
	V	MAX	780	3,55	2,85	611	18,0	3,08	2,66	530	13,9	2,34	2,34	402	8,5	1,93	1,93	332	6,0			
	IV		680	3,20	2,55	550	15,0	2,79	2,38	480	11,7	2,09	2,09	359	6,9	1,73	1,73	298	4,9			
	III	MED	570	2,82	2,22	485	12,0	2,45	2,07	421	9,3	1,82	1,82	313	5,4	1,51	1,51	260	3,8			
	II	MIN	445	2,31	1,80	397	8,5	2,02	1,68	347	6,6	1,48	1,48	255	3,8	1,23	1,23	212	2,7			
	I		360	1,95	1,50	335	6,3	1,70	1,40	292	4,9	1,23	1,23	212	2,7	1,02	1,02	175	1,9			

Correction factors for different R.H.

R.H.	WT:	7/12°C	8/13°C	10/15°C	12/17°C
48%	Pc	0,95	0,94	1,00	1,00
	Ps	1,00	1,00	1,00	1,00
46%	Pc	0,90	0,88	1,00	1,00
	Ps	1,00	1,00	1,00	1,00

LEGEND

- WT = Water temperature
- Pc = Cooling total emission
- Ps = Cooling sensible emission
- Qw = Water flow
- Dp(c) = Water pressure drop
- Speed = Fan speed
- MAX = High speed
- MED = Medium speed
- MIN = Low speed
- Qv = Air flow

Cooling emission of 1 row additional coil

Entering air temperature: 27°C – R.H.: 50%

MODEL	Speed		WT: 7/12 °C					WT: 8/13 °C				WT: 10/15 °C				WT: 12/17 °C			
			Qv	Pc	Ps	Qw	Dp(c)	Pc	Ps	Qw	Dp(c)	Pc	Ps	Qw	Dp(c)	Pc	Ps	Qw	Dp(c)
			m³/h	kW	kW	l/h	kPa	kW	kW	l/h	kPa	kW	kW	l/h	kPa	kW	kW	l/h	kPa
CRT 13+1	VI		225	1,03	0,81	177	2,4	0,91	0,76	157	1,9	0,68	0,68	117	1,1	0,57	0,57	98	0,8
	V	MAX	190	0,91	0,70	157	1,9	0,81	0,66	139	1,5	0,58	0,58	100	0,8	0,50	0,50	86	0,6
	IV		165	0,82	0,62	141	1,6	0,73	0,59	126	1,3	0,52	0,51	89	0,7	0,44	0,44	76	0,5
	III	MED	135	0,72	0,54	124	1,3	0,64	0,51	110	1,0	0,46	0,44	79	0,6	0,39	0,39	67	0,4
	II	MIN	110	0,62	0,46	107	1,0	0,55	0,43	95	0,8	0,40	0,37	69	0,4	0,33	0,33	57	0,3
	I		90	0,53	0,38	91	0,7	0,47	0,36	81	0,6	0,34	0,31	58	0,3	0,27	0,27	46	0,2
CRT 23+1	VI		290	1,47	1,10	253	5,6	1,31	1,03	225	4,5	0,96	0,90	165	2,6	0,79	0,79	136	1,8
	V	MAX	240	1,30	0,96	224	4,5	1,15	0,90	198	3,6	0,85	0,78	146	2,1	0,69	0,69	119	1,4
	IV		210	1,17	0,85	201	3,7	1,04	0,80	179	3,0	0,77	0,70	132	1,8	0,61	0,61	105	1,2
	III	MED	170	0,99	0,71	170	2,8	0,88	0,67	151	2,3	0,66	0,58	114	1,3	0,51	0,51	88	0,8
	II	MIN	140	0,87	0,62	150	2,2	0,77	0,58	132	1,8	0,58	0,50	100	1,1	0,45	0,45	77	0,7
	I		115	0,74	0,52	127	1,6	0,66	0,49	114	1,3	0,49	0,42	84	0,8	0,37	0,37	64	0,5
CRT 33+1	VI		415	2,39	1,72	411	19,1	2,14	1,62	368	15,6	1,62	1,41	279	9,4	1,24	1,24	213	5,8
	V	MAX	345	2,09	1,48	359	15,0	1,87	1,39	322	12,3	1,42	1,22	244	7,5	1,07	1,07	184	4,5
	IV		300	1,86	1,31	320	12,3	1,67	1,24	287	10,1	1,27	1,08	218	6,1	0,95	0,95	163	3,6
	III	MED	255	1,65	1,16	284	10,0	1,48	1,09	255	8,2	1,13	0,95	194	5,0	0,84	0,84	144	2,9
	II	MIN	200	1,34	0,93	230	6,9	1,21	0,87	208	5,7	0,92	0,76	158	3,5	0,67	0,67	115	2,0
	I		165	1,13	0,78	194	5,1	1,02	0,73	175	4,2	0,78	0,64	134	2,6	0,56	0,56	96	1,4
CRT 53+1	VI		580	3,34	2,40	574	13,9	3,00	2,26	516	11,4	2,26	1,98	389	6,9	1,74	1,74	299	4,2
	V	MAX	475	2,87	2,04	494	10,6	2,58	1,92	444	8,7	1,95	1,67	335	5,3	1,47	1,47	253	3,2
	IV		420	2,62	1,85	451	9,1	2,35	1,74	404	7,4	1,78	1,52	306	4,5	1,33	1,33	229	2,7
	III	MED	345	2,25	1,57	387	6,9	2,02	1,48	347	5,7	1,54	1,29	265	3,5	1,14	1,14	196	2,0
	II	MIN	275	1,85	1,28	318	4,9	1,66	1,20	286	4,0	1,27	1,05	218	2,5	0,92	0,92	158	1,4
	I		215	1,51	1,04	260	3,4	1,36	0,97	234	2,8	1,04	0,85	179	1,8	0,75	0,75	129	1,0
CRT 63+1	VI		735	3,99	2,91	686	18,9	3,56	2,74	612	15,5	2,68	2,40	461	9,2	2,11	2,11	363	6,0
	V	MAX	600	3,43	2,47	590	14,6	3,08	2,33	530	11,9	2,32	2,03	399	7,2	1,79	1,79	308	4,5
	IV		520	3,09	2,20	531	12,1	2,77	2,07	476	9,9	2,09	1,81	359	6,0	1,59	1,59	273	3,6
	III	MED	440	2,72	1,92	468	9,7	2,44	1,81	420	8,0	1,85	1,58	318	4,8	1,39	1,39	239	2,9
	II	MIN	345	2,25	1,57	387	6,9	2,02	1,48	347	5,7	1,54	1,29	265	3,5	1,14	1,14	196	2,0
	I		285	1,91	1,32	329	5,2	1,71	1,24	294	4,3	1,31	1,08	225	2,6	0,95	0,95	163	1,5
CRT 73+1	VI		895	4,98	3,59	857	32,6	4,46	3,38	767	26,7	3,38	2,97	581	16,2	2,61	2,61	449	10,1
	V	MAX	735	4,34	3,10	746	25,6	3,90	2,91	671	21,1	2,96	2,55	509	12,8	2,24	2,24	385	7,8
	IV		640	3,89	2,75	669	21,1	3,49	2,59	600	17,4	2,66	2,26	458	10,6	1,99	1,99	342	6,3
	III	MED	540	3,41	2,39	587	16,8	3,07	2,25	528	13,8	2,34	1,96	402	8,5	1,73	1,73	298	4,9
	II	MIN	420	2,78	1,93	478	11,7	2,51	1,82	432	9,7	1,92	1,58	330	6,0	1,40	1,40	241	3,4
	I		345	2,37	1,63	408	8,9	2,14	1,54	368	7,3	1,64	1,34	282	4,5	1,18	1,18	203	2,5

Correction factors for different R.H.

R.H.	WT:	7/12°C	8/13°C	10/15°C	12/17°C
48%	Pc	0,95	0,94	1,00	1,00
	Ps	1,00	1,00	1,00	1,00
46%	Pc	0,90	0,88	1,00	1,00
	Ps	1,00	1,00	1,00	1,00

LEGEND

- WT = Water temperature
- Pc = Cooling total emission
- Ps = Cooling sensible emission
- Qw = Water flow
- Dp(c) = Water pressure drop
- Speed = Fan speed
- MAX = High speed
- MED = Medium speed
- MIN = Low speed
- Qv = Air flow

Cooling emission of 1 row additional coil

Entering air temperature: 26°C – R.H.: 50%

MODEL	Speed		WT: 7/12 °C					WT: 8/13 °C					WT: 10/15 °C					WT: 12/17 °C				
			Qv	Pc	Ps	Qw	Dp(c)	Pc	Ps	Qw	Dp(c)	Pc	Ps	Qw	Dp(c)	Pc	Ps	Qw	Dp(c)			
			m³/h	kW	kW	l/h	kPa	kW	kW	l/h	kPa	kW	kW	l/h	kPa	kW	kW	l/h	kPa			
CRT 13+1	VI		225	0,90	0,76	155	1,9	0,78	0,71	134	1,4	0,62	0,62	107	1,0	0,52	0,52	89	0,7			
	V	MAX	190	0,80	0,66	138	1,5	0,69	0,62	119	1,2	0,54	0,54	93	0,7	0,45	0,45	77	0,5			
	IV		165	0,72	0,59	124	1,3	0,63	0,55	108	1,0	0,48	0,48	83	0,6	0,40	0,40	69	0,4			
	III	MED	135	0,64	0,51	110	1,0	0,55	0,48	95	0,8	0,42	0,42	72	0,5	0,35	0,35	60	0,3			
	II	MIN	110	0,55	0,43	95	0,8	0,48	0,40	83	0,6	0,36	0,36	62	0,4	0,30	0,30	52	0,3			
	I		90	0,46	0,36	79	0,6	0,41	0,34	71	0,5	0,30	0,30	52	0,3	0,25	0,25	43	0,2			
CRT 23+1	VI		290	1,30	1,04	224	4,5	1,14	0,97	196	3,5	0,86	0,86	148	2,1	0,72	0,72	124	1,5			
	V	MAX	240	1,15	0,90	198	3,6	1,00	0,84	172	2,8	0,75	0,75	129	1,7	0,62	0,62	107	1,2			
	IV		210	1,04	0,80	179	3,0	0,91	0,75	157	2,4	0,67	0,67	115	1,4	0,56	0,56	96	1,0			
	III	MED	170	0,88	0,67	151	2,2	0,77	0,63	132	1,8	0,54	0,54	93	0,9	0,47	0,47	81	0,7			
	II	MIN	140	0,77	0,58	132	1,8	0,68	0,54	117	1,4	0,48	0,47	83	0,8	0,41	0,41	71	0,6			
	I		115	0,65	0,49	112	1,3	0,58	0,46	100	1,1	0,41	0,39	71	0,6	0,34	0,34	58	0,4			
CRT 33+1	VI		415	2,13	1,62	366	15,6	1,88	1,52	323	12,4	1,35	1,31	232	6,8	1,14	1,14	196	5,0			
	V	MAX	345	1,86	1,40	320	12,3	1,65	1,31	284	9,8	1,18	1,13	203	5,4	0,98	0,98	169	3,8			
	IV		300	1,66	1,24	286	10,1	1,47	1,16	253	8,1	1,06	1,00	182	4,5	0,87	0,87	150	3,1			
	III	MED	255	1,48	1,09	255	8,2	1,31	1,02	225	6,5	0,95	0,88	163	3,7	0,77	0,77	132	2,5			
	II	MIN	200	1,20	0,88	206	5,7	1,06	0,82	182	4,6	0,78	0,71	134	2,6	0,62	0,62	107	1,7			
	I		165	1,01	0,73	174	4,2	0,90	0,69	155	3,4	0,66	0,59	114	1,9	0,51	0,51	88	1,2			
CRT 53+1	VI		580	2,98	2,26	513	11,4	2,63	2,12	452	9,1	1,88	1,83	323	4,9	1,59	1,59	273	3,6			
	V	MAX	475	2,56	1,92	440	8,7	2,26	1,80	389	7,0	1,63	1,55	280	3,8	1,35	1,35	232	2,7			
	IV		420	2,34	1,74	402	7,4	2,07	1,63	356	5,9	1,49	1,40	256	3,3	1,22	1,22	210	2,3			
	III	MED	345	2,01	1,48	346	5,7	1,78	1,38	306	4,5	1,29	1,19	222	2,5	1,04	1,04	179	1,7			
	II	MIN	275	1,65	1,20	284	4,0	1,46	1,13	251	3,2	1,07	0,97	184	1,8	0,85	0,85	146	1,2			
	I		215	1,35	0,98	232	2,8	1,20	0,91	206	2,3	0,88	0,78	151	1,3	0,68	0,68	117	0,8			
CRT 63+1	VI		735	3,55	2,74	611	15,5	3,13	2,57	538	12,3	2,29	2,29	394	7,0	1,92	1,92	330	5,1			
	V	MAX	600	3,06	2,33	526	11,9	2,70	2,18	464	9,5	1,93	1,88	332	5,2	1,63	1,63	280	3,8			
	IV		520	2,75	2,08	473	9,9	2,43	1,95	418	7,9	1,74	1,68	299	4,3	1,46	1,46	251	3,1			
	III	MED	440	2,43	1,81	418	7,9	2,15	1,70	370	6,3	1,54	1,46	265	3,5	1,27	1,27	218	2,4			
	II	MIN	345	2,01	1,48	346	5,7	1,78	1,38	306	4,5	1,29	1,19	222	2,5	1,04	1,04	179	1,7			
	I		285	1,70	1,25	292	4,2	1,51	1,16	260	3,4	1,10	1,00	189	1,9	0,87	0,87	150	1,3			
CRT 73+1	VI		895	4,44	3,39	764	26,7	3,93	3,18	676	21,4	2,82	2,75	485	11,7	2,39	2,39	411	8,6			
	V	MAX	735	3,88	2,92	667	21,0	3,43	2,74	590	16,8	2,47	2,37	425	9,3	2,05	2,05	353	6,6			
	IV		640	3,47	2,60	597	17,3	3,08	2,43	530	13,9	2,23	2,10	384	7,8	1,82	1,82	313	5,4			
	III	MED	540	3,05	2,25	525	13,8	2,70	2,11	464	11,1	1,96	1,82	337	6,2	1,58	1,58	272	4,2			
	II	MIN	420	2,49	1,82	428	9,6	2,21	1,70	380	7,8	1,62	1,47	279	4,4	1,28	1,28	220	2,9			
	I		345	2,12	1,54	365	7,3	1,89	1,44	325	5,9	1,39	1,24	239	3,4	1,08	1,08	186	2,2			

Correction factors for different R.H.

R.H.	WT:	7/12°C	8/13°C	10/15°C	12/17°C
48%	Pc	0,95	0,94	1,00	1,00
	Ps	1,00	1,00	1,00	1,00
46%	Pc	0,90	0,88	1,00	1,00
	Ps	1,00	1,00	1,00	1,00

LEGEND

- WT = Water temperature
- Pc = Cooling total emission
- Ps = Cooling sensible emission
- Qw = Water flow
- Dp(c) = Water pressure drop
- Speed = Fan speed
- MAX = High speed
- MED = Medium speed
- MIN = Low speed
- Qv = Air flow

Cooling emission of 1 row additional coil

Entering air temperature: 25°C – R.H.: 50%

MODEL	Speed		WT: 7/12 °C					WT: 8/13 °C				WT: 10/15 °C				WT: 12/17 °C			
			Qv	Pc	Ps	Qw	Dp(c)	Pc	Ps	Qw	Dp(c)	Pc	Ps	Qw	Dp(c)	Pc	Ps	Qw	Dp(c)
			m³/h	kW	kW	l/h	kPa	kW	kW	l/h	kPa	kW	kW	l/h	kPa	kW	kW	l/h	kPa
CRT 13+1	VI		225	0,78	0,71	134	1,4	0,67	0,67	115	1,1	0,57	0,57	98	0,8	0,46	0,46	79	0,6
	V	MAX	190	0,69	0,62	119	1,2	0,59	0,58	101	0,9	0,50	0,50	86	0,6	0,40	0,40	69	0,4
	IV		165	0,63	0,55	108	1,0	0,53	0,51	91	0,7	0,44	0,44	76	0,5	0,36	0,36	62	0,4
	III	MED	135	0,55	0,48	95	0,8	0,47	0,44	81	0,6	0,39	0,39	67	0,4	0,31	0,31	53	0,3
	II	MIN	110	0,47	0,40	81	0,6	0,44	0,37	76	0,4	0,33	0,33	57	0,3	0,27	0,27	46	0,2
	I		90	0,40	0,34	69	0,5	0,35	0,31	60	0,3	0,27	0,27	46	0,2	0,22	0,22	38	0,2
CRT 23+1	VI		290	1,14	0,97	196	3,6	0,97	0,91	167	2,7	0,79	0,79	136	1,8	0,65	0,65	112	1,3
	V	MAX	240	1,00	0,84	172	2,9	0,86	0,79	148	2,2	0,69	0,69	119	1,4	0,56	0,56	96	1,0
	IV		210	0,91	0,75	157	2,4	0,78	0,70	134	1,8	0,61	0,61	105	1,2	0,50	0,50	86	0,8
	III	MED	170	0,77	0,63	132	1,8	0,66	0,58	114	1,4	0,52	0,52	89	0,9	0,42	0,42	72	0,6
	II	MIN	140	0,67	0,54	115	1,4	0,58	0,51	100	1,1	0,45	0,45	77	0,7	0,37	0,37	64	0,5
	I		115	0,57	0,46	98	1,1	0,50	0,43	86	0,8	0,37	0,37	64	0,5	0,31	0,31	53	0,3
CRT 33+1	VI		415	1,88	1,52	323	12,5	1,63	1,42	280	9,6	1,24	1,24	213	5,9	1,03	1,03	177	4,2
	V	MAX	345	1,64	1,31	282	9,9	1,43	1,22	246	7,6	1,07	1,07	184	4,6	0,89	0,89	153	3,2
	IV		300	1,47	1,16	253	8,1	1,27	1,08	218	6,3	0,95	0,95	163	3,7	0,79	0,79	136	2,6
	III	MED	255	1,30	1,02	224	6,6	1,13	0,95	194	5,1	0,84	0,84	144	3,0	0,70	0,70	120	2,1
	II	MIN	200	1,06	0,82	182	4,6	0,92	0,76	158	3,6	0,67	0,67	115	2,0	0,56	0,56	96	1,4
	I		165	0,89	0,69	153	3,4	0,78	0,64	134	2,6	0,56	0,56	96	1,5	0,47	0,47	81	1,0
CRT 53+1	VI		580	2,63	2,13	452	9,1	2,28	1,98	392	7,0	1,74	1,74	299	4,3	1,44	1,44	248	3,0
	V	MAX	475	2,26	1,80	389	7,0	1,96	1,68	337	5,4	1,48	1,48	255	3,2	1,22	1,22	210	2,3
	IV		420	2,06	1,63	354	5,9	1,79	1,52	308	4,6	1,34	1,34	230	2,7	1,11	1,11	191	1,9
	III	MED	345	1,77	1,39	304	4,5	1,54	1,29	265	3,5	1,14	1,14	196	2,1	0,95	0,95	163	1,5
	II	MIN	275	1,46	1,13	251	3,2	1,27	1,05	218	2,5	0,93	0,93	160	1,4	0,77	0,77	132	1,0
	I		215	1,20	0,92	206	2,3	1,04	0,85	179	1,8	0,75	0,75	129	1,0	0,62	0,62	107	0,7
CRT 63+1	VI		735	3,12	2,58	537	12,3	2,70	2,41	464	9,5	2,11	2,11	363	6,1	1,74	1,74	299	4,3
	V	MAX	600	2,70	2,19	464	9,5	2,34	2,04	402	7,3	1,79	1,79	308	4,5	1,48	1,48	255	3,2
	IV		520	2,43	1,95	418	7,9	2,11	1,82	363	6,1	1,60	1,60	275	3,7	1,32	1,32	227	2,6
	III	MED	440	2,14	1,70	368	6,4	1,86	1,59	320	4,9	1,39	1,39	239	2,9	1,15	1,15	198	2,1
	II	MIN	345	1,77	1,39	304	4,5	1,54	1,29	265	3,5	1,14	1,14	196	2,1	0,95	0,95	163	1,5
	I		285	1,51	1,17	260	3,4	1,31	1,09	225	2,7	0,96	0,96	165	1,5	0,79	0,79	136	1,1
CRT 73+1	VI		895	3,92	3,19	674	21,4	3,40	2,98	585	16,6	2,61	2,61	449	10,3	2,16	2,16	372	7,3
	V	MAX	735	3,42	2,74	588	16,9	2,97	2,56	511	13,1	2,25	2,25	387	7,9	1,86	1,86	320	5,6
	IV		640	3,07	2,44	528	13,9	2,67	2,27	459	10,8	2,00	2,00	344	6,4	1,65	1,65	284	4,5
	III	MED	540	2,69	2,12	463	11,1	2,35	1,97	404	8,6	1,73	1,73	298	5,0	1,44	1,44	248	3,5
	II	MIN	420	2,20	1,71	378	7,8	1,92	1,59	330	6,1	1,41	1,41	243	3,5	1,16	1,16	200	2,4
	I		345	1,88	1,44	323	5,9	1,64	1,34	282	4,6	1,19	1,19	205	2,6	0,98	0,98	169	1,8

Correction factors for different R.H.

R.H.	WT:	7/12°C	8/13°C	10/15°C	12/17°C
48%	Pc	0,95	0,94	1,00	1,00
	Ps	1,00	1,00	1,00	1,00
46%	Pc	0,90	0,88	1,00	1,00
	Ps	1,00	1,00	1,00	1,00

LEGEND

- WT = Water temperature
- Pc = Cooling total emission
- Ps = Cooling sensible emission
- Qw = Water flow
- Dp(c) = Water pressure drop
- Speed = Fan speed
- MAX = High speed
- MED = Medium speed
- MIN = Low speed
- Qv = Air flow

Heating emission of 3 row coil

Entering air temperature: 20°C

MODEL	Speed		WT: 70/60 °C				WT: 60/50 °C			WT: 50/40 °C			WT: 50/45 °C			WT: 45/40 °C		
			Qv	Ph	Qw	Dp(c)	Ph	Qw	Dp(c)	Ph	Qw	Dp(c)	Ph	Qw	Dp(c)	Ph	Qw	Dp(c)
			m³/h	kW	l/h	kPa	kW	l/h	kPa	kW	l/h	kPa	kW	l/h	kPa	kW	l/h	kPa
CRT 13	VI		240	2,52	217	2,6	1,91	164	1,7	1,30	112	0,9	1,54	265	3,9	1,24	213	2,7
	V	MAX	200	2,17	187	2,0	1,64	141	1,3	1,12	96	0,7	1,33	229	3,0	1,07	184	2,1
	IV		175	1,94	167	1,6	1,47	126	1,0	1,00	86	0,5	1,18	203	2,5	0,95	163	1,7
	III	MED	140	1,64	141	1,2	1,25	108	0,8	0,85	73	0,4	1,00	172	1,9	0,81	139	1,3
	II	MIN	115	1,39	120	0,9	1,06	91	0,6	0,73	63	0,3	0,85	146	1,4	0,69	119	1,0
	I		95	1,17	101	0,7	0,89	77	0,4	0,61	52	0,2	0,72	124	1,0	0,58	100	0,7
CRT 23	VI		305	3,33	286	5,4	2,53	218	3,4	1,74	150	1,8	2,03	349	8,1	1,64	282	5,7
	V	MAX	250	2,86	246	4,1	2,18	187	2,6	1,50	129	1,4	1,74	299	6,2	1,41	243	4,3
	IV		225	2,61	224	3,5	1,99	171	2,3	1,37	118	1,2	1,59	273	5,3	1,29	222	3,7
	III	MED	180	2,16	186	2,5	1,65	142	1,6	1,14	98	0,9	1,32	227	3,8	1,07	184	2,7
	II	MIN	150	1,88	162	2,0	1,44	124	1,3	1,00	86	0,7	1,15	198	3,0	0,93	160	2,1
	I		125	1,59	137	1,5	1,22	105	1,0	0,85	73	0,5	0,97	167	2,2	0,79	136	1,6
CRT 33	VI		440	5,07	436	17,0	3,89	335	11,0	2,71	233	6,0	3,10	533	25,6	2,51	432	18,0
	V	MAX	370	4,31	371	12,8	3,31	285	8,3	2,31	199	4,5	2,63	452	19,2	2,13	366	13,6
	IV		315	3,83	329	10,4	2,94	253	6,7	2,05	176	3,7	2,34	402	15,6	1,91	329	11,1
	III	MED	275	3,41	293	8,5	2,62	225	5,5	1,83	157	3,0	2,08	358	12,7	1,69	291	9,0
	II	MIN	205	2,64	227	5,4	2,03	175	3,5	1,42	122	1,9	1,61	277	8,1	1,31	225	5,7
	I		170	2,21	190	3,9	1,70	146	2,6	1,19	102	1,4	1,35	232	5,9	1,10	189	4,2
CRT 53	VI		610	6,98	600	11,7	5,35	460	7,5	3,72	320	4,1	4,26	733	17,5	3,46	595	12,3
	V	MAX	495	5,87	505	8,6	4,50	387	5,6	3,14	270	3,0	3,58	616	12,9	2,91	501	9,1
	IV		440	5,34	459	7,3	4,10	353	4,7	2,86	246	2,6	3,26	561	10,9	2,64	454	7,7
	III	MED	360	4,54	390	5,5	3,49	300	3,5	2,43	209	1,9	2,77	476	8,2	2,25	387	5,8
	II	MIN	285	3,65	314	3,7	2,81	242	2,4	1,96	169	1,3	2,23	384	5,6	1,81	311	4,0
	I		225	2,97	255	2,6	2,28	196	1,7	1,60	138	0,9	1,81	311	3,9	1,47	253	2,8
CRT 63	VI		780	8,55	735	16,6	6,55	563	10,7	4,55	391	5,8	5,22	898	25,0	4,23	728	17,6
	V	MAX	635	7,23	622	12,4	5,54	476	8,0	3,85	331	4,4	4,41	759	18,6	3,58	616	13,1
	IV		560	6,49	558	10,2	4,97	427	6,6	3,46	298	3,6	3,96	681	15,4	3,21	552	10,8
	III	MED	475	5,66	487	8,1	4,34	373	5,2	3,02	260	2,9	3,46	595	12,1	2,80	482	8,5
	II	MIN	370	4,59	395	5,6	3,53	304	3,6	2,46	212	2,0	2,81	483	8,4	2,28	392	5,9
	I		305	3,89	335	4,2	2,99	257	2,7	2,09	180	1,5	2,38	409	6,3	1,93	332	4,4
CRT 73	VI		945	10,44	898	27,6	8,01	689	17,8	5,58	480	9,8	6,37	1096	41,4	5,17	889	29,2
	V	MAX	780	8,91	766	20,9	6,84	588	13,5	4,77	410	7,4	5,44	936	31,4	4,42	760	22,1
	IV		680	7,96	685	17,1	6,11	525	11,1	4,27	367	6,1	4,86	836	25,7	3,95	679	18,1
	III	MED	570	6,91	594	13,3	5,31	457	8,7	3,71	319	4,8	4,22	726	20,0	3,43	590	14,2
	II	MIN	445	5,62	483	9,3	4,32	372	6,0	3,02	260	3,3	3,43	590	13,9	2,79	480	9,8
	I		360	4,66	401	6,7	3,59	309	4,3	2,52	217	2,4	2,85	490	10,0	2,32	399	7,1

LEGEND

- WT = Water temperature Speed = Fan speed
- Ph = Emission MAX = High speed
- Qw = Water flow MED = Medium speed
- Dp(c) = Water pressure drop MIN = Low speed
- Qv = Air flow

Heating emission of 1 row additional coil

Entering air temperature: 20°C

MODEL	Speed		WT: 80/70 °C				WT: 75/65 °C				WT: 70/60 °C				WT: 65/55 °C				WT: 60/50 °C				WT: 55/45 °C			
			Qv	Ph	Qw	Dp(c)	Ph	Qw	Dp(c)	Ph	Qw	Dp(c)	Ph	Qw	Dp(c)	Ph	Qw	Dp(c)	Ph	Qw	Dp(c)	Ph	Qw	Dp(c)		
			m³/h	kW	l/h	kPa	kW	l/h	kPa	kW	l/h	kPa	kW	l/h	kPa	kW	l/h	kPa	kW	l/h	kPa	kW	l/h	kPa		
CRT 13+1	VI		225	1,44	124	2,8	1,28	110	2,3	1,13	97	1,9	0,98	84	1,5	0,84	72	1,1	0,69	59	0,8					
	V	MAX	190	1,27	109	2,3	1,14	98	1,9	1,01	87	1,5	0,87	75	1,2	0,74	64	0,9	0,61	52	0,7					
	IV		165	1,15	99	1,9	1,03	89	1,6	0,91	78	1,3	0,79	68	1,0	0,67	58	0,8	0,55	47	0,6					
	III	MED	135	1,01	87	1,5	0,91	78	1,3	0,80	69	1,0	0,70	60	0,8	0,59	51	0,6	0,49	42	0,5					
	II	MIN	110	0,87	75	1,2	0,78	67	1,0	0,69	59	0,8	0,60	52	0,6	0,51	44	0,5	0,42	36	0,4					
	I		90	0,75	65	0,9	0,68	58	0,8	0,60	52	0,6	0,52	45	0,5	0,44	38	0,4	0,37	32	0,3					
CRT 23+1	VI		290	1,96	169	5,6	1,76	151	4,7	1,56	134	3,9	1,36	117	3,1	1,17	101	2,4	0,97	83	1,8					
	V	MAX	240	1,73	149	4,5	1,55	133	3,8	1,38	119	3,1	1,21	104	2,5	1,03	89	1,9	0,86	74	1,4					
	IV		210	1,57	135	3,8	1,41	121	3,2	1,25	108	2,6	1,09	94	2,1	0,94	81	1,6	0,78	67	1,2					
	III	MED	170	1,34	115	2,9	1,21	104	2,4	1,07	92	2,0	0,94	81	1,6	0,80	69	1,2	0,67	58	0,9					
	II	MIN	140	1,19	102	2,3	1,07	92	2,0	0,95	82	1,6	0,83	71	1,3	0,71	61	1,0	0,60	52	0,7					
	I		115	1,03	89	1,8	0,93	80	1,5	0,82	71	1,3	0,72	62	1,0	0,62	53	0,8	0,52	45	0,6					
CRT 33+1	VI		415	3,02	260	15,6	2,72	234	13,2	2,43	209	11,0	2,13	183	8,9	1,84	158	6,9	1,54	132	5,2					
	V	MAX	345	2,66	229	12,5	2,40	206	10,6	2,14	184	8,8	1,88	162	7,1	1,62	139	5,6	1,36	117	4,2					
	IV		300	2,40	206	10,4	2,17	187	8,8	1,93	166	7,3	1,70	146	5,9	1,46	126	4,6	1,23	106	3,5					
	III	MED	255	2,16	186	8,6	1,95	168	7,3	1,74	150	6,1	1,53	132	4,9	1,32	114	3,8	1,11	95	2,9					
	II	MIN	200	1,80	155	6,3	1,62	139	5,3	1,45	125	4,4	1,27	109	3,6	1,10	95	2,8	0,92	79	2,1					
	I		165	1,55	133	4,8	1,40	120	4,1	1,25	108	3,4	1,10	95	2,8	0,95	82	2,2	0,80	69	1,6					
CRT 53+1	VI		580	4,13	355	5,3	3,72	320	4,5	3,30	284	3,7	2,89	249	3,0	2,48	213	2,3	2,07	178	1,7					
	V	MAX	475	3,59	309	4,1	3,23	278	3,5	2,87	247	2,9	2,52	217	2,3	2,16	186	1,8	1,80	155	1,3					
	IV		420	3,31	285	3,6	2,98	256	3,0	2,65	228	2,5	2,32	200	2,0	1,99	171	1,6	1,66	143	1,2					
	III	MED	345	2,89	249	2,8	2,60	224	2,4	2,31	199	2,0	2,03	175	1,6	1,74	150	1,2	1,46	126	0,9					
	II	MIN	275	2,43	209	2,1	2,19	188	1,8	1,95	168	1,5	1,71	147	1,2	1,47	126	0,9	1,23	106	0,7					
	I		215	2,05	176	1,5	1,84	158	1,3	1,64	141	1,1	1,44	124	0,9	1,24	107	0,7	1,04	89	0,5					
CRT 63+1	VI		735	4,88	420	7,1	4,39	378	6,0	3,90	335	4,9	3,41	293	4,0	2,93	252	3,1	2,44	210	2,3					
	V	MAX	600	4,24	365	5,5	3,81	328	4,7	3,39	292	3,9	2,96	255	3,1	2,54	218	2,4	2,12	182	1,8					
	IV		520	3,84	330	4,7	3,45	297	3,9	3,07	264	3,2	2,69	231	2,6	2,31	199	2,0	1,93	166	1,5					
	III	MED	440	3,42	294	3,8	3,08	265	3,2	2,74	236	2,7	2,40	206	2,1	2,06	177	1,7	1,72	148	1,2					
	II	MIN	345	2,89	249	2,8	2,60	224	2,4	2,31	199	2,0	2,03	175	1,6	1,74	150	1,2	1,46	126	0,9					
	I		285	2,50	215	2,2	2,25	194	1,9	2,00	172	1,5	1,76	151	1,2	1,51	130	1,0	1,26	108	0,7					
CRT 73+1	VI		895	6,12	526	12,4	5,51	474	10,5	4,91	422	8,7	4,30	370	7,0	3,70	318	5,5	3,10	267	4,1					
	V	MAX	735	5,37	462	9,9	4,84	416	8,4	4,31	371	6,9	3,78	325	5,6	3,25	280	4,4	2,73	235	3,2					
	IV		640	4,85	417	8,3	4,37	376	7,0	3,90	335	5,8	3,42	294	4,7	2,94	253	3,6	2,47	212	2,7					
	III	MED	540	4,31	371	6,7	3,88	334	5,7	3,46	298	4,7	3,04	261	3,8	2,62	225	3,0	2,20	189	2,2					
	II	MIN	420	3,60	310	4,9	3,25	280	4,1	2,89	249	3,4	2,54	218	2,8	2,19	188	2,2	1,84	158	1,6					
	I		345	3,14	270	3,8	2,83	243	3,2	2,52	217	2,7	2,22	191	2,2	1,91	164	1,7	1,60	138	1,3					

LEGEND

- WT = Water temperature Speed = Fan speed
- Ph = Emission MAX = High speed
- Qw = Water flow MED = Medium speed
- Dp(c) = Water pressure drop MIN = Low speed
- Qv = Air flow

Water pressure drop

3 row coil

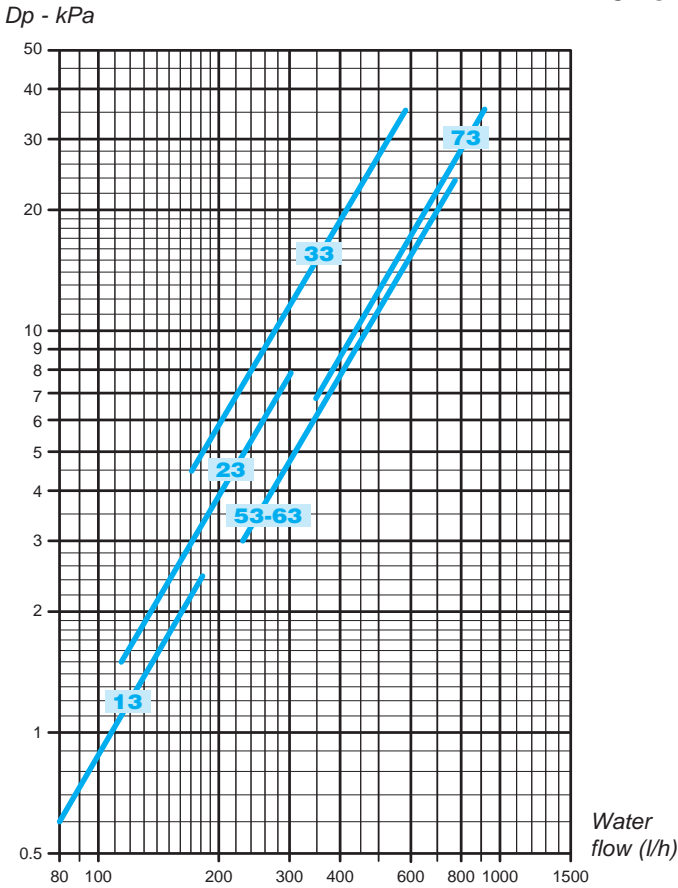

The water pressure drop figures refer to a mean water temperature of **10°C**; for different temperatures, multiply the pressure drop figures by the correction factors **K**.

°C	20	30	40	50	60	70	80
K	0,94	0,90	0,86	0,82	0,78	0,74	0,70

1 row additional coil

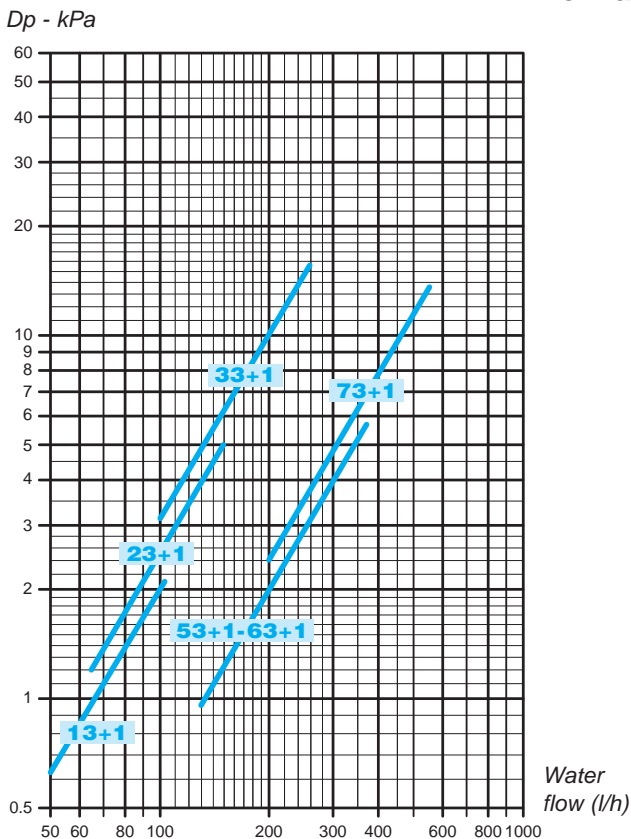

The water pressure drop figures refer to a mean water temperature of **65°C**; for different temperatures, multiply the pressure drop figures by the correction factors **K**.

°C	40	50	60	70	80
K	1,14	1,08	1,02	0,96	0,90

VBP
main coil 3 way valve

Control valve kit:
3 way valve, ON-OFF,
with electric motor and mounting kit
with micrometric lockshield valve.

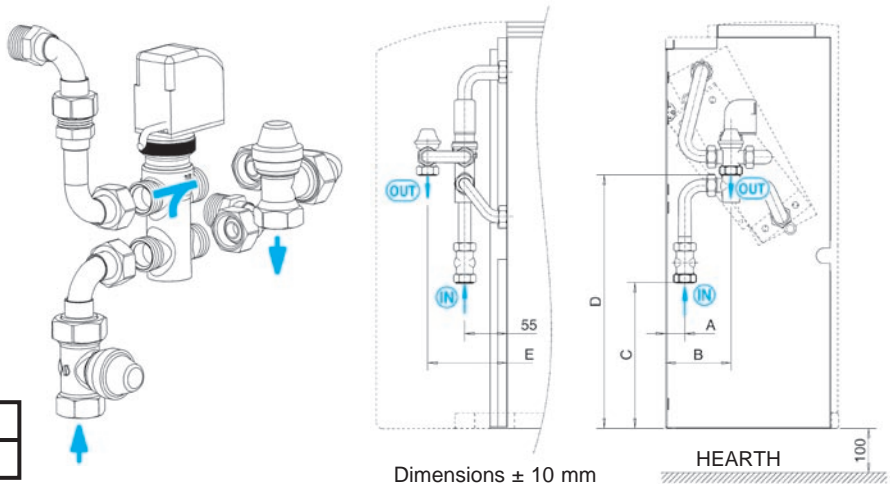

VERSION	CRT
MODEL	MV - MO - MVB - IV - IO

Dimensions ± 10 mm

Mod.	Dimensions (mm)					Valve			Micrometric lockshield valve			Code	
	A	B	C	D	E	DN	(Ø)	Kvs	DN	(Ø)	Kvs	FITTED	NOT FITTED
1 ÷ 5	25	85	190	290	105	15	1/2"	1,6	15	1/2" F	2	9066561H	9066560H
6 - 7	25	85	190	290	105	20	3/4"	2,5	15	1/2" F	2	9060471H	9060474H

VBA
additional coil 3 way valve

Control valve kit:
3 way valve, ON-OFF,
with electric motor and mounting kit
with micrometric lockshield valve.

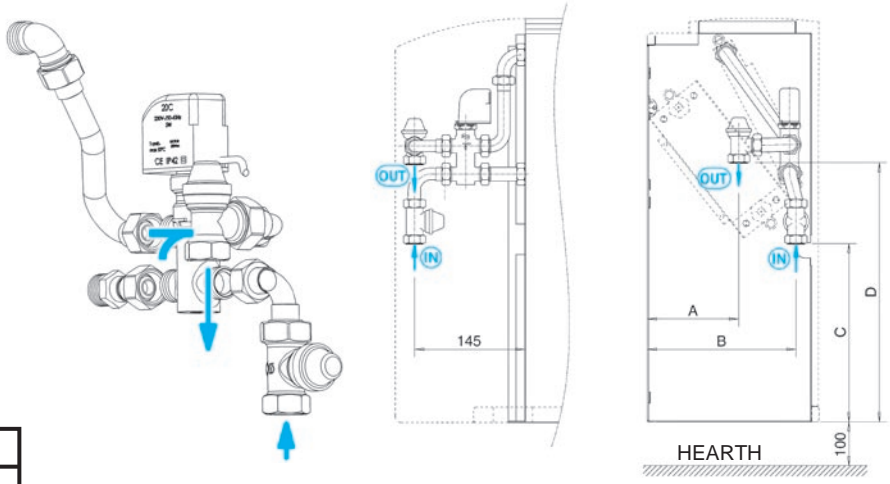

VERSION	CRT
MODEL	MV - MO - MVB - IV - IO

Dimensions ± 10 mm

Mod.	Dimensions (mm)				Valve			Micrometric lockshield valve			Code	
	A	B	C	D	DN	(Ø)	Kvs	DN	(Ø)	Kvs	FITTED	NOT FITTED
1 ÷ 7	120	195	240	340	15	1/2"	1,6	15	1/2" F	2	9060472H	9060475H

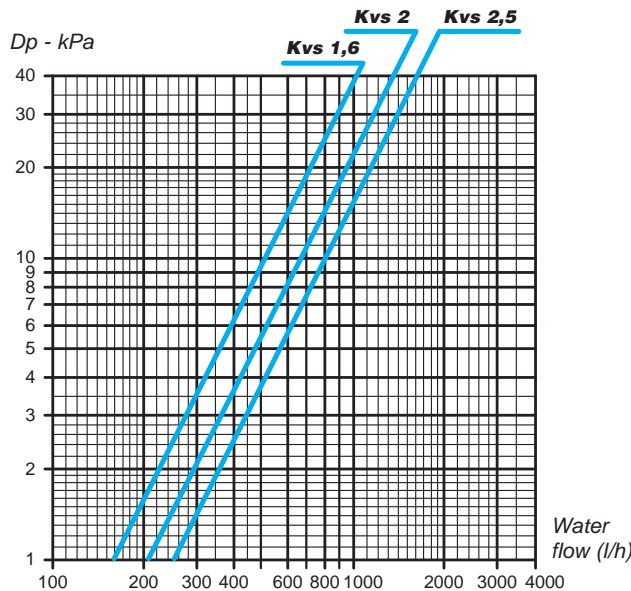

VS
simplified kit for 3 way valve
(concealed model only)

3 way valve, (ON-OFF)
with electric motor and mounting kit.
Valve with flat connection
without micrometric lockshield valve.

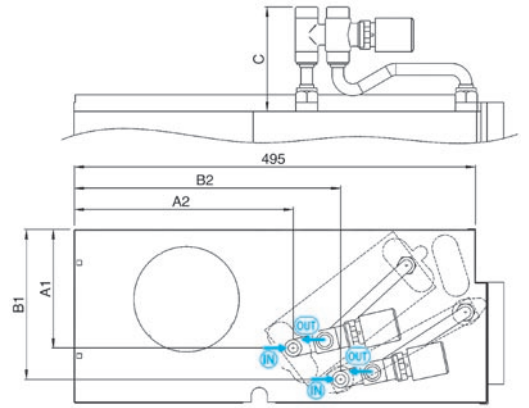
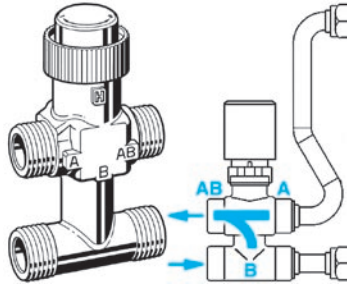

Dimensions ± 10 mm

VERSION	CRT
MODEL	IV - IO

Mod.	Dimensions (mm)					MAIN				ADDITIONAL					
	MAIN		ADDITIONAL		C	Valve			Code		Valve			Code	
	A1	A2	B1	B2		DN	(Ø)	Kvs	FITTED	NOT FITTED	DN	(Ø)	Kvs	FITTED	NOT FITTED
1 ÷ 5	152	270	185	330	116	15	1/2"	1,6	9066571H	9066570H	15	1/2"	1,6	9060483H	9060480H
6 - 7	152	268	185	330	124	20	3/4"	2,5	9060484H	9060481H					

V2
2 way valve
for main and additional coil

Control valve kit:
2 way valve, ON-OFF,
with electric motor and mounting kit.

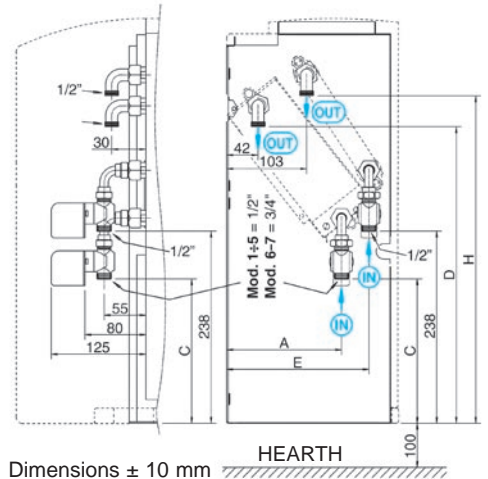
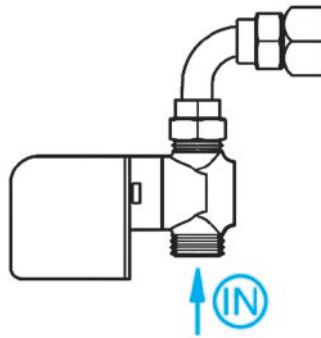

Dimensions ± 10 mm

VERSION	CRT
MODEL	MV - MO - MVB - IV - IO

Mod.	Dimensions (mm)					MAIN				ADDITIONAL					
	MAIN		ADDITIONAL		H	Valve			Code		Valve			Code	
	A	C	D	E		DN	(Ø)	Kvs	FITTED	NOT FITTED	DN	(Ø)	Kvs	FITTED	NOT FITTED
1 ÷ 5	149	180	386	186	456	15	1/2"	1,7	9060476H	9060478H	15	1/2"	1,7	9060476H	9060478H
6 - 7	150	181	438	186	456	20	3/4"	2,8	9060477H	9060479H					

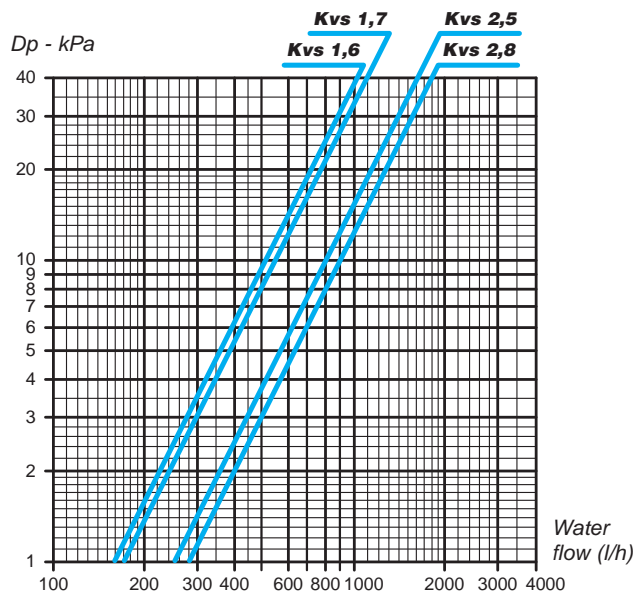

BEL electric heater

1 PHASE 230V

Electric heater with integral:
safety thermostat and relay control.

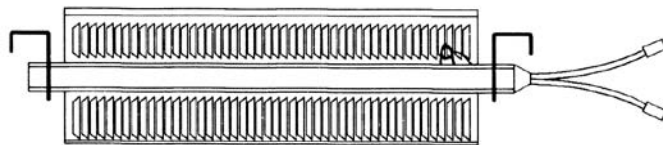

VERSION	CRT		
MODEL	MV - MO - MVB - IV - IO		

SIZE	1		2		3			5 - 6			7		
WATT	650	1000	600	400	1500	900	600	2000	1250	750	2500	1500	1000
CODE	9066491	9066492	9066482	9066472	9066493	9066483	9066473	9066495	9066485	9066475	9066497	9066487	9066477

BSV extension condensate collection tray
to cover valve assembly
(for vertical units)

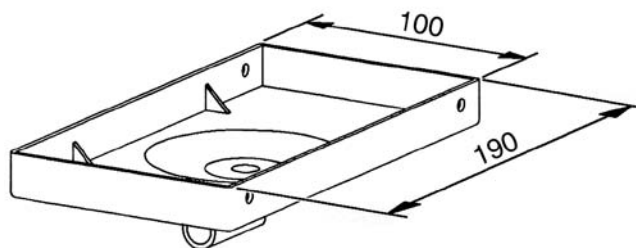

VERSION	CRT	
MODEL	MV - IV - MVB (vertical)	
CODE	6060400	

BSO extension condensate collection tray
to cover valve assembly
(for horizontal units)

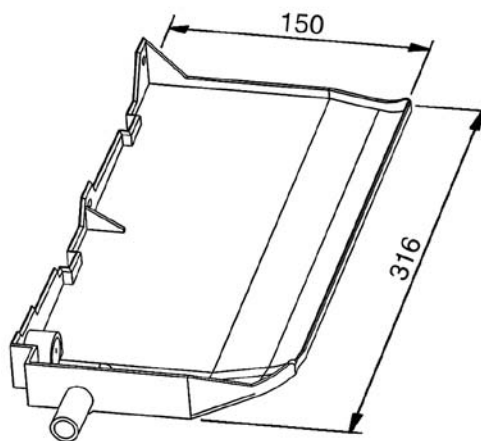

VERSION	CRT	
MODEL	MO - IO (horizontal)	
CONNECTION SIDE	LEFT	RIGHT
TYPE	BSO-SX	BSO-DX
CODE	6060402	6060403

SCR plastic condensate drain pipe with fast connection
(allows correct condensate drain)

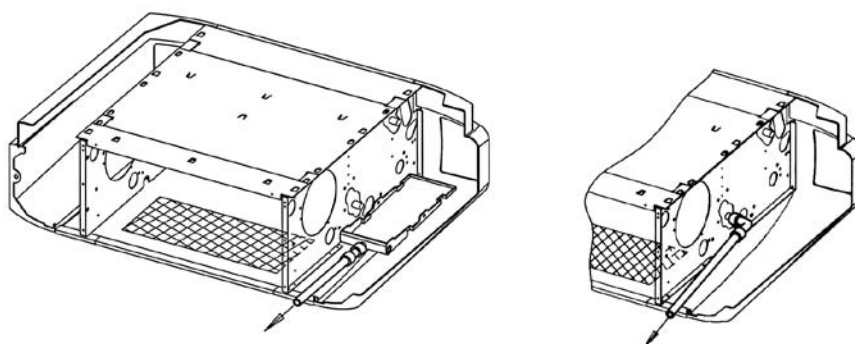

VERSION	CRT	
MODEL	MO - IO	
CODE	6060420	

PAP feet

VERSION	CRT
MODEL	MV

SIZE	L	CODE
1	330	9066351
2	430	9066351
3	645	9066351
5 - 6	860	9066351
7	1119	9066351

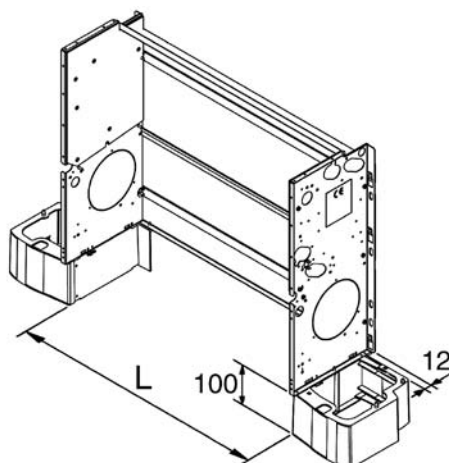

GAP

Aluminium low intake grid
(to be installed with PAP feet)

VERSION	CRT
MODEL	MV

SIZE	CODE
1	9066541
2	9066542
3	9066543
5 - 6	9066545
7	9066547

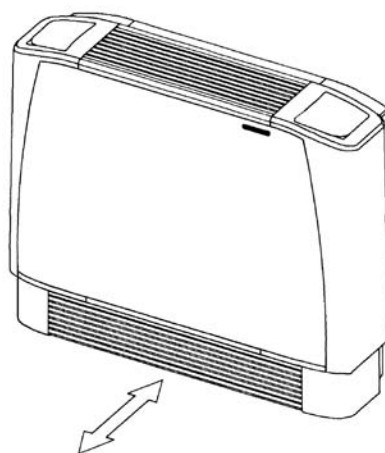

KAF frontal intake kit

Bottom closing panel and filter sliding guides.

VERSION	CRT
MODEL	IV - IO

SIZE	CODE
1	9066501
2	9066502
3	9066503
5 - 6	9066505
7	9066507

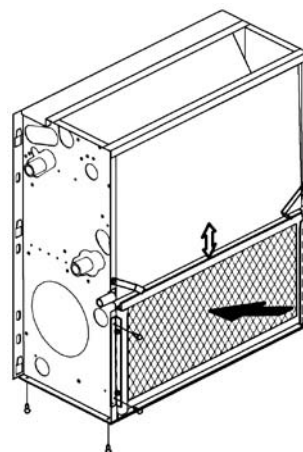

**PCV rear closing panel
(for vertical units)**

VERSION	CRT
MODEL	MV - MVB

SIZE	CODE
1	9066511
2	9066512
3	9066513
5 - 6	9066515
7	9066517

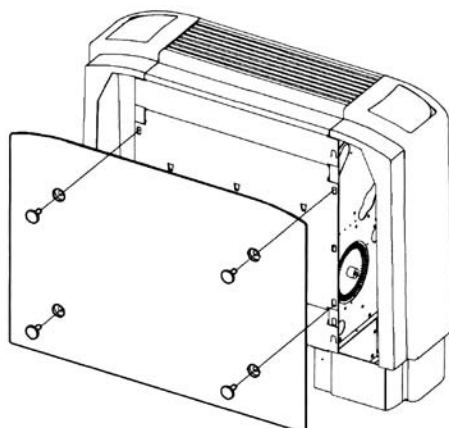

PCO bottom closing panel
(for horizontal units)

VERSION	CRT
MODEL	MO - MVB

SIZE	CODE
1	9066521
2	9066522
3	9066523
5 - 6	9066525
7	9066527

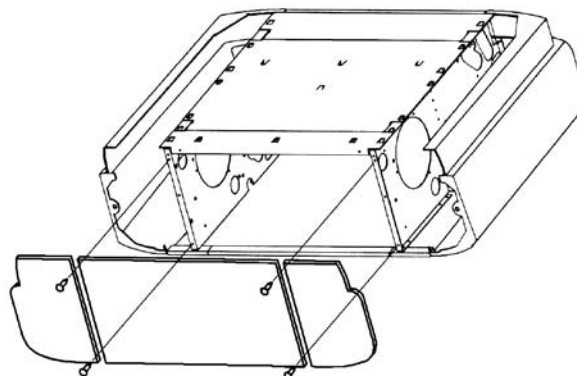

SAE fresh air mixing damper

(can be motorized on request)

VERSION	CRT
MODEL	MV - IV - IO

SIZE	A	L	CODE
1	183	354	9066531
2	183	454	9066532
3	183	669	9066533
5 - 6	183	884	9066535
7	183	1099	9066537

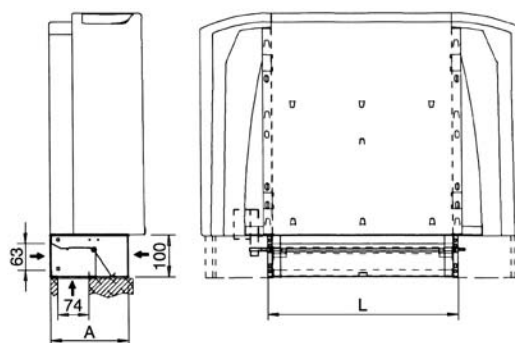

Belimo accessory

DESCRIPTION	TYPE
Belimo motor fitted on the unit for motorized working of the damper (available with "IAQ" control only)	BESAE

FRD straight inlet flange

Can be used together with GRAG air inlet grid.
Made of galvanized steel.

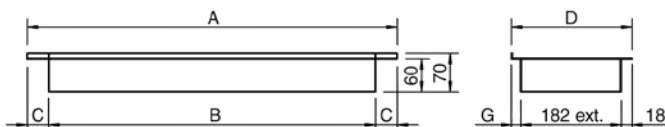

SIZE	TYPE	A	B	C	D	G	CODE
1	FRD - 1	354	290	32	216	16	9066451
2	FRD - 2	454	390	32	216	16	9060720
3	FRD - 3/4	669	590	39,5	216	16	9060721
5 - 6	FRD - 5/6	884	790	47	216	16	9060722
7	FRD - 7	1099	990	54,5	216	16	9060723

VERSION	CRT
MODEL	IV - IO

GRAG air inlet grid

To be used with FRD straight inlet flange.
Made of anodized aluminium.

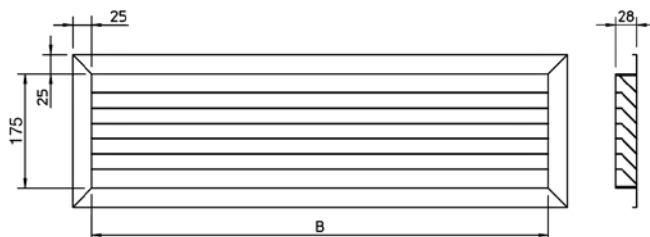

SIZE	TYPE	DESCRIPTION	B	CODE
1	GRAG - 1	Grid 300x200	275	9066431
2	GRAG - 2	Grid 400x200	375	9060764
3	GRAG - 3/4	Grid 600x200	575	9060765
5 - 6	GRAG - 5/6	Grid 800x200	775	9060766
7	GRAG - 7/9	Grid 1000x200	975	9060767

VERSION	CRT
MODEL	IV - IO

FMD straight outlet flange

Made of galvanized steel.

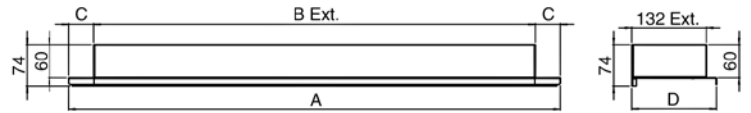

SIZE	TYPE	A	B	C	D	CODE
1	FMD - 1	352	290	31	152	9066371
2	FMD - 2	452	390	31	152	9066372
3	FMD - 3/4	667	590	38,5	152	9066373
5 - 6	FMD - 5/6	882	790	46	152	9066375
7	FMD - 7	1097	990	53,5	152	9066377

VERSION	CRT
MODEL	IV - IO

BMA air outlet grid

Double louvre grid to be fitted to the duct, to the FMD straight outlet flange or to the FM 90° 90° outlet flange. Made of anodized aluminium.

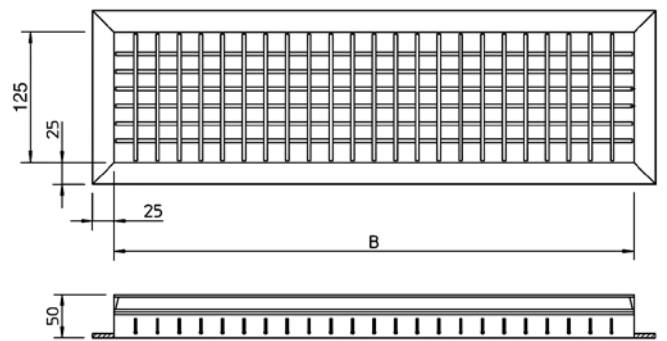

SIZE	TYPE	B	CODE
1	BMA - 1	275	9066411
2	BMA - 2	375	9060750
3	BMA - 3/4	575	9060751
5 - 6	BMA - 5/6	775	9060752
7	BMA - 7/9	975	9060753

VERSION	CRT
MODEL	IV - IO

IDENTIFICATION	CODE
CB	9066300



- ON-OFF switch and 3 speed switch.
- Without thermostatic control.
- It allows to control the low temperature cut-out thermostat (TMM).

IDENTIFICATION	CODE
CB-T	9066301



- ON-OFF switch.
- 3 speed switch.
- Summer/Winter switch.
- Electronic room thermostat for fan or valves control (ON-OFF).
- It allows to control the low temperature cut-out thermostat (TMM).
- It allows to control the chilled water valve (ON-OFF) and the electric heater (BEL) only in case that hot water is not used in winter (otherwise please use CB-R-IAQ control with on/off switch for the electric heater).

IDENTIFICATION	CODE
CB-C	9066302



- ON-OFF switch.
- 3 speed switch.
- It allows to control the summer or winter cycle with centralized and remote switch, or an automatic change-over fitted on the water pipe (for 2-tube installations only).
- Electronic room thermostat for fan or valves control (ON-OFF).
- It allows to control the low temperature cut-out thermostat (TME).
- It allows to control the chilled water valve (ON-OFF) and the electric heater (BEL) only in case that hot water is not used in winter (otherwise please use CB-R-IAQ control with on/off switch for the electric heater).

IDENTIFICATION	CODE
CB-AU	9066303



- Manual or automatic speed switch: on Auto Mode there is the automatic speed selection in accordance to the difference between room temperature and setpoint. When the setpoint is reached the fan go on OFF.
- Summer/Winter switch.
- Electronic room thermostat for valve(s) control (ON-OFF).
- Simultaneous thermostatic control of the valves and fan.
- It allows to control the low temperature cut-out (TME).
- It allows to control the chilled water valve (ON-OFF) and the electric heater (BEL) only in case that hot water is not used in winter (otherwise please use CB-AU-IAQ control with on/off switch for the electric heater).
- It allows to control the summer/winter cycle with a centralized and remote switch or with an automatic change-over fitted on the water pipe (for 2-tube installations only).

N.B.: with 4 pipe installations and continuous chilled and hot water supply, it allows the automatic summer/winter change-over in accordance to the room temperature (-1°C = Winter, +1°C = Summer, Neutral Zone 2°C).

IDENTIFICATION	CODE
MO-3V	9060160

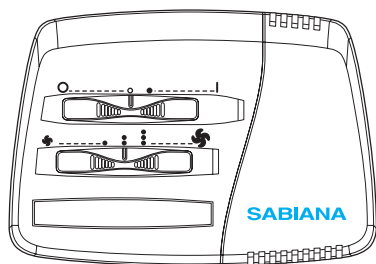

Dimensions: 133x93x37 mm

- ON-OFF switch and 3 speed switch.
- Without thermostatic control.
- It allows to control the low temperature cut-out thermostat (TMM).

IDENTIFICATION	CODE
CR-T	9066330

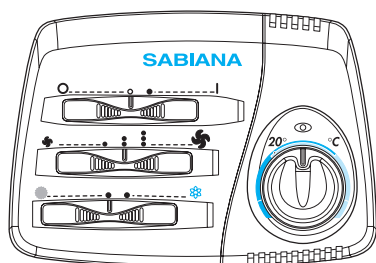

Dimensions: 133x93x37 mm

- ON-OFF switch.
- Manual 3 speed switch.
- Manual Summer/Winter switch.
- Electronic room thermostat for fan or valves control (ON-OFF).
- It allows to control the low temperature cut-out thermostat (TMM).
- It allows to control the chilled water valve (ON-OFF) and the electric heater (BEL) only in case that hot water is not used in winter (otherwise please use TMO-T-IAQ control with on/off switch for the electric heater).

IDENTIFICATION	CODE
TMO-T	9060161

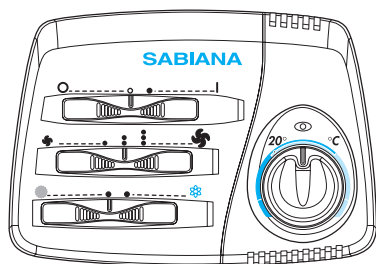

Dimensions: 133x93x37 mm

- ON-OFF switch.
- Manual 3 speed switch.
- Summer/Winter switch.
- Electronic room thermostat for fan or valves control (ON-OFF).
- It allows to control the low temperature cut-out thermostat (TME).
- It allows to control the chilled water valve (ON-OFF) and the electric heater (BEL) only in case that hot water is not used in winter (otherwise please use TMO-T-IAQ control with on/off switch for the electric heater).
- It allows to control the summer/winter cycle with a centralized and remote switch or with an automatic change-over fitted on the water pipe (for 2-tube installations only).

IDENTIFICATION	CODE
TMO-T-AU	9060164

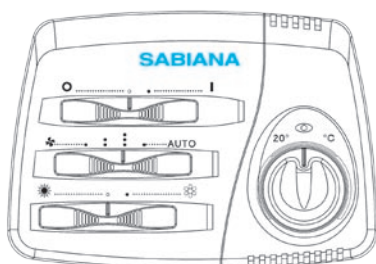

Dimensions: 133x93x37 mm

- ON-OFF switch.
- Manual or automatic 3 speed switch.
- Summer/Winter switch.
- Electronic room thermostat for fan or valves control (ON-OFF).
- Simultaneous thermostatic control of the valves and fan.
- It allows to control the low temperature cut-out thermostat (TME).
- It allows to control the chilled water valve (ON-OFF) and the electric heater (BEL) only in case that hot water is not used in winter (otherwise please use TMO-T-AU-IAQ control with on/off switch for the electric heater).
- It allows to control the summer/winter cycle with a centralized and remote switch or with an automatic change-over fitted on the water pipe (for 2-tube installations only).

N.B.: with 4 pipe installations and continuous chilled and hot water supply, it allows the automatic summer winter change-over in accordance to the room temperature (-1°C = Winter, +1°C = Summer, Neutral Zone 2°C).

IDENTIFICATION	CODE
TMO-503-S	9060171



Dimensions: 118x87x8 mm

The TMO-503-S control for fan coils without valves, is designed to be installed in a DIN 503 wall box. It is easy to use, it has a big and clear display, and a great precision. The control is supplied integral with the external frame, but it is possible to use frames of the most known brand on the market (BTicino, Vimar, AVE, Gewiss). The highest working electric absorption is 200 W. If the fan coil has an higher absorption or more units are connected to the same control, the speed switch SEL-CR must be installed.

- Manual or automatic speed switch.
- Manual Summer/Winter switch.
- Electronic thermostat for fan control (ON-OFF).
- It allows to control the low temperature cut-out thermostat, included with the control.

IDENTIFICATION	CODE
TMO-503-SV2	9060173



Dimensions: 118x87x8 mm

The TMO-503-SV2 control for fan coils with valves, is designed to be installed in a DIN 503 wall box. It is easy to use, it has a big and clear display, and a great precision. The control is supplied integral with the external frame, but it is possible to use frames of the most known brand on the market (BTicino, Vimar, AVE, Gewiss). The highest working electric absorption is 200 W. If the fan coil has an higher absorption or more units are connected to the same control, the speed switch SEL-CR must be installed.

- Manual or automatic speed switch.
- Manual Summer/Winter switch.
- Electronic thermostat for valves control (ON-OFF).
- Simultaneous thermostatic control of the valves and fan.
- It allows to control the low temperature cut-out thermostat, included with the control.

N.B.: with 4 pipe installations and continuous chilled and hot water supply, it allows the automatic summer/winter change-over in accordance to the room temperature (-1°C = Winter, +1°C = Summer, Neutral Zone 2°C).

IDENTIFICATION	CODE
TMO-DI	9060165



Dimensions on the wall: 133x93x27 mm
Dimensions in the DIN 503 box: 133x93x18 mm

To be installed on the wall or in the DIN 503 box.

- Manual or automatic speed switch.
- Manual or centralized Summer/Winter switch.
- Electronic thermostat for fan control (ON-OFF).
- Electronic thermostat for valve(s) control (ON-OFF).
- Simultaneous thermostatic control of the valves and fan.
- It allows to control the low temperature cut-out thermostat (TME).
- It allows to control the chilled water valve (ON-OFF) and the electric heater (BEL) only in case that hot water is not used in winter.
- It allows to control the fan and the electric heater.
- It allows to control up to 10 units with SEL-DI speed switch.

N.B.: with 4 pipe installations and continuous chilled and hot water supply, it allows the automatic summer/winter change-over in accordance to the room temperature (-1°C = Winter, +1°C = Summer, Neutral Zone 2°C).

IDENTIFICATION	CODE
T2T	9060174



Dimensions: 128x75x25 mm

2 pipes units only.

- ON-OFF switch.
- 3 speed switch.
- Manual Summer/Winter switch.
- Thermostatic control on the fan.
- Thermostatic control on the valve and continuous fan operation.
- Simultaneous thermostatic control of the valve and fan.
- Cannot be used with speed switch (master-slave).

IDENTIFICATION

CODE

CB-R-IAQ

9066306



- ON-OFF switch.
- 3 speed switch.
- Summer/Winter switch.
- Electric heater ON-OFF switch.
- Electronic room thermostat for fan or valves control (ON-OFF).
- It allows to control the low temperature cut-out thermostat (TME).
- It allows to control the chilled water valve (ON-OFF) and the electric heater (BEL) only in case that hot water is not used in winter.
- It allows to control the summer/winter cycle with a centralized and remote switch or with an automatic change-over fitted on the water pipe (for 2-tube installations only).

IDENTIFICATION

CODE

CB-AU-IAQ

9066307



- Manual or automatic speed switch: on Auto Mode there is the automatic speed selection in accordance to the difference between room temperature and setpoint. When the setpoint is reached the fan and the filter go on OFF.
- Summer/Winter switch.
- Electric heater ON-OFF switch.
- Electronic room thermostat for valve(s) control (ON-OFF).
- It allows to control the low temperature cut-out (TME).
- It allows to control the chilled water valve (ON-OFF) and the electric heater (BEL) only in case that hot water is not used in winter.
- It allows to control the summer/winter cycle with a centralized and remote switch or with an automatic change-over fitted on the water pipe (for 2-tube installations only).

N.B.: with 4 pipe installations and continuous chilled and hot water supply, it allows the automatic summer/winter change-over in accordance to the room temperature (-1.6°C = Winter, +1.6°C = Summer, Neutral Zone 3.2°C).

IDENTIFICATION	CODE
TMO-T-IAQ	9063021

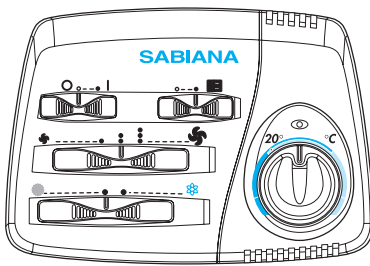

Dimensions: 133x93x37 mm

- ON-OFF switch.
- Manual 3 speed switch.
- Summer/Winter switch.
- Electric heater ON-OFF switch.
- Electronic room thermostat for fan or valves control (ON-OFF).
- It allows to control the low temperature cut-out thermostat (TME).
- It allows to control the chilled water valve (ON-OFF) and the electric heater (BEL) only in case that hot water is not used in winter.
- It allows to control the summer/winter cycle with a centralized and remote switch or with an automatic change-over fitted on the water pipe (for 2-tube installations only).

IDENTIFICATION	CODE
TMO-T-AU-IAQ	9063023

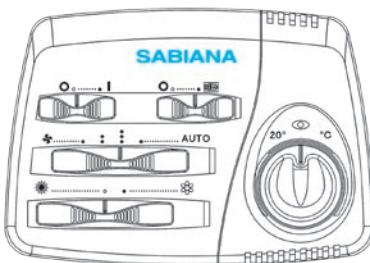

Dimensions: 133x93x37 mm

- ON-OFF switch.
- Manual or automatic 3 speed switch.
- Summer/Winter switch.
- Electric heater ON-OFF switch.
- Electronic room thermostat for fan or valves control (ON-OFF).
- Simultaneous thermostatic control on the valves and fan.
- It allows to control the low temperature cut-out thermostat (TME).
- It allows to control the chilled water valve (ON-OFF) and the electric heater (BEL) only in case that hot water is not used in winter.
- It allows to control the summer/winter cycle with a centralized and remote switch or with an automatic change-over fitted on the water pipe (for 2-tube installations only).

N.B.: with 4 pipe installations and continuous chilled and hot water supply, it allows the automatic summer/winter change-over in accordance to the room temperature (-1°C = Winter, +1°C = Summer, Neutral Zone 2°C).

IDENTIFICATION	CODE
TMO-DI	9060165



Dimensions on the wall: 133x93x27 mm
Dimensions in the DIN 503 box: 133x93x18 mm

- To be installed on the wall or in the DIN 503 box.
- Manual or automatic speed switch.
- Manual or centralized Summer/Winter switch.
- Electronic thermostat for fan control (ON-OFF).
- Electronic thermostat for valve(s) control (ON-OFF).
- Simultaneous thermostatic control of the valves and fan.
- It allows to control the low temperature cut-out thermostat (TME).
- It allows to control the chilled water valve (ON-OFF) and the electric heater (BEL) only in case that hot water is not used in winter.
- It allows to control the fan and the electric heater.
- It allows to control up to 10 units with SEL-DI speed switch.

N.B.: with 4 pipe installations and continuous chilled and hot water supply, it allows the automatic summer/winter change-over in accordance to the room temperature (-1°C = Winter, +1°C = Summer, Neutral Zone 2°C).

IDENTIFICATION

CODE

SEL-CB

9066304

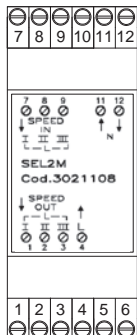

For MV-MVB models.

- Speed switch (Slave).
- It allows to control up to 8 units with only one centralized wall control (1 speed switch for each unit).
- For controls CR-T, TMO-T, TMO-T-AU, TMO-503-S and TMO-503-SV2.

IDENTIFICATION

CODE

SEL-CR

9066311

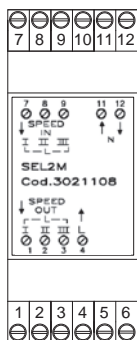

For MO-IV-IO models.

- Speed switch (Slave).
- It allows to control up to 8 units with only one centralized wall control (1 speed switch for each unit).
- For controls CR-T, TMO-T, TMO-T-AU, TMO-503-S and TMO-503-SV2.

IDENTIFICATION

CODE

SEL-DI

9060139

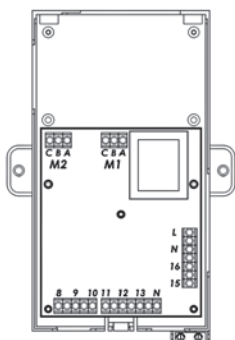

- Speed switch (Slave) for TMO-DI
- It allows to control up to 10 units with only one TMO-DI centralized wall control.

TME low temperature cut-out thermostat

To be fitted between the coil fins; when connecting the control, the TME probe cable must be separated from the power supply wires.

To be used with the following controls:

CB-C, CB-AU, TMO-T, TMO-T-AU, TMO-DI and corresponding IAQ controls.

It stops the fan when

the water temperature is lower than 38°C

and it starts the fan when is higher than 42°C.



VERSION	CRT
MODEL	MV - MO - MVB - IV - IO
CODE	3021091

TMM low temperature cut-out thermostat

To be installed in contact with the hot water circuit.

To eliminate cold air blow.

Installed by the installing engineer.

To be used with the following controls:

CB, CB-T, MO-3V, CR-T.

For units working on heating only.

It stops the fan when

the water temperature is lower than 30°C

and it starts the fan when is higher than 38°C.

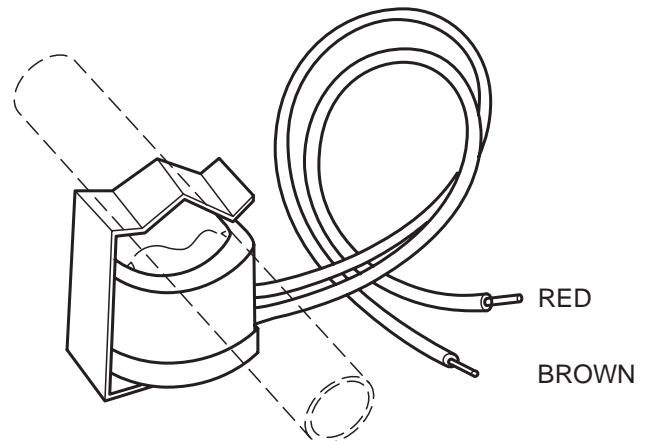

VERSION	CRT
MODEL	MV - MO - MVB - IV - IO
CODE	9053048

Change-Over CH 15-25

Automatic summer/winter switch

to be installed in contact with the water circuit.

For 2-tube installations only

(not to be used with 2 way valve).

To be used with the following controls:

CB-C, CB-AU, TMO-T, TMO-T-AU, TMO-DI.

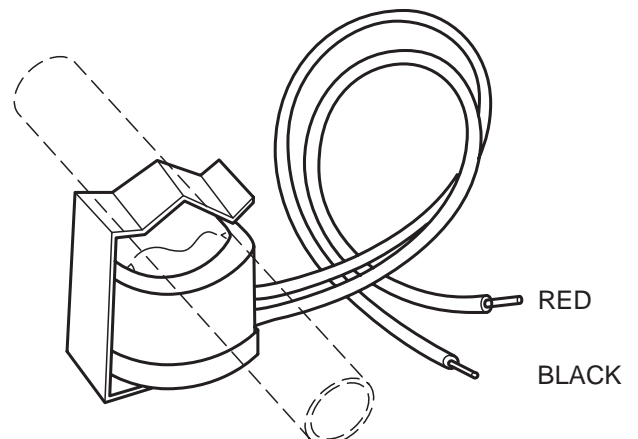

VERSION	CRT
MODEL	MV - MO - MVB - IV - IO
CODE	9053049



FreeSabiana

Free Sabiana is an innovative, **fully wireless**, electronic system for use with fan coil units, based on radio communication.

This technology **provides installation flexibility and a more accurate measurement of the room temperature**. The probe can be moved until the most suitable position is found, without the worry of changes in the environment layout and of its furniture and also without mounting it on a wall.

If a new fan coil unit is added, no electrical wiring for the control system is required: just define the control unit and the probe which regulates it. The improved measurement accuracy derives from the possibility to position the probe near the typical location of the user: this enables to keep the temperature exactly at the required value with more energy savings compared with a traditional measurement system.

Transmission is based on communication protocol IEE802.15.4, the most suitable way to transmit a relatively low amount of information with very low consumption and high reliability.

The system has been certified by a leading independent body, officially recognized by the EU authorities and its sale has been authorized in all the EU and EFTA countries.

Main components

Free Sabiana includes 3 main components:

- A remote **control** which features a button panel and LCD display and can be wall-mounted or positioned on a dedicated table support. It enables the control of all the operating variables of the fan coil units in different configurations. The control is battery powered. The temperature and the operating speed of the fan coil unit are set with two large buttons featuring user friendly graphics.

DESCRIPTION	IDENTIFICATION	CODE
Remote control	Free-Com	9060572



Control unit with support

DESCRIPTION	IDENTIFICATION	CODE
Power unit fitted on the unit	Free-Upm	9060571
Power unit not fitted on the unit	Free-Ups	9060570

- A **power unit** to be installed on the fan coil (fan coil interface). It controls the fan and the valves of the fan coil. The power unit is connected to the electric supply. The power unit receives the information required to control the fan coil both from the remote control and locally, such as the temperature of the coil.



Power unit

DESCRIPTION	IDENTIFICATION	CODE
Temperature probe	Free-Sen	9060573

- A room **temperature probe**, which can be wall-mounted or positioned on a dedicated table support. It is a battery powered device, able to measure the air temperature in the spot where it is positioned, generating temperature information which is communicated to the other devices.



Probe with support

Main features of the remote control

The control enables:

- Fan coil on/off switching
- Fan speed selection (high - medium - low - automatic)
- Summer/winter operation selection
- Valve on/off
- Real time clock setting
- Temperature setting
- Daily switch on/off setting (timer function)
- Enable/disable the timer function
- Activation of the (optional) electrostatic filter
- Activation of the (optional) electric heater



Main information displayed:

- ① On-off status
- ② Summer operation
- ③ Winter operation
- ④ Automatic season change
- ⑤ Electric heater
- ⑥ Electrostatic filter
- ⑦ Room temperature (with decimal accuracy)

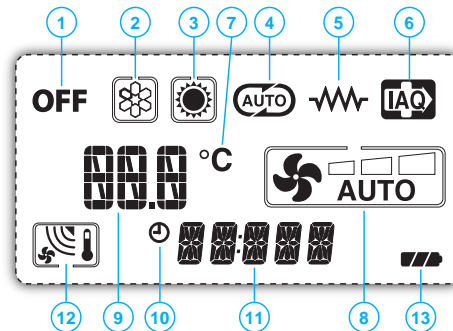

- ⑧ Fan operating speed
- ⑨ Required/measured temperature
- ⑩ Timer
- ⑪ Clock
- ⑫ Transmission signal
- ⑬ Battery level

Main features of the power unit to be installed on the fan coil



The power unit controls the fan and the valves of the fan coil. The power unit receives the information required to control such units both from the remote control and locally.

It enables the following main actions:

- Fan on/off at a set speed
- Fan speed change (fan on/off)
- Water valve/s on/off (1 valve for 2 tube system - 2 valves for 4 tube system)
- Fan speed change operating the water valve/s
- Control of the electric resistance as main heating unit or as integration to the battery supplied with hot water
- Control of the operation of the electrostatic filter (in parallel to the fan)
- Management of the dead zone function for 4-tube systems
- Available functional inputs:
 - Consent for remote on/off
 - Consent for remote Summer/Winter switch (centralized)
 - Consent for the activation of the Energy Saving function with setting change
 - Minimum probe
 - Probe for season change

Main features of the temperature probe



This device is able to measure the temperature of the air in the spot where it is positioned and to transmit it by means of radio communication to the other devices in the system. It is battery powered and can be freely positioned in the area to be air-conditioned.

Display:

- Measured environment temperature
- Transmission signal
- Clock
- Battery status

DESCRIPTION	IDENTIFICATION	CODE
Infra-red remote control with electronic board fitted on the unit (MV-MO-MVB only)	IRC-M	9060175
Infra-red remote control with electronic board not fitted on the unit (IV-IO only)	IRC-S	9060176
ETN +/-3°C with electronic board fitted on the unit	IRC-ETN-M	9060166
ETN +/-3°C with electronic board not fitted on the unit	IRC-ETN-S	9060167

The Carisma units can be supplied with a micro-processor managing system operated by an infra-red remote control with liquid crystall display or by a wall-mounted IRC-ETN control.

Integral with the unit is an electronic board with RS485 communicating connection which can control up to 20 units connected between them. The electronic board is of master/slave mode and the serial communicating connection allows the serial connection; in the master/slave connection of more units, it is recommended to install the infra-red receiver on the master unit.

IRC controls are not suitable for BEL electric heater.

The units with IR control are supplied with room temperature probe and water temperature probe (cut-out thermostat).

The infra-red remote control features the following functions:

- Temperature set.
- Fan speed switch with possible automatic speed selection.
- 24 hours on/off program.
- ON/OFF cooling valve control.
- ON/OFF heating valve control.
- Control of the valves only or of the valves and the fan together.
- Valve control of 2 or 4 pipe systems with winter/summer switch on the infra-red control.
- Valve control of 4 pipe systems with automatic heating/cooling mode selection with 2°C dead zone.
- Activating the sensor connected to the T3 contact of the board (non active in the standard configuration), it works like a cut-out thermostat: fitted between the coil fins it stops the fan when the water temperature is lower than 38°C and it starts the fan when the water temperature reaches 42°C.



The wall-mounted control features the following functions:

- Switch the appliance ON and OFF.
- Set the fan speed.
- Set the range of temperature settings (default +/- 3 °C, modifiable on site up to +/- 9°C).
- Modify the set point determined by the system by a value of +/- X°C.

The Maxinet system (see the following pages) can set the operating mode, the set point and all other operating parameters of the unit, as well as display the settings made by the user. The Maxinet system always has priority over the ETN controller. For the correct use of the system, also see the manual for the Fan-coil with remote control and the Maxinet supervision program.



IRC electronic board

The electronic board, fitted inside the electrical panel, can manage different control modes so as to best satisfy the requirements of the installation. These modes are selected by suitably positioning the configuration dipswitches, which define the following main functions:

- **2 pipe / 4 pipe system**
- Operation **without / with** remote control
- Continuous ventilation
- Close valve and stop fan in cooling mode (autofan function)
- Close valve and stop fan in heating mode (autofan function)
- Close valve and stop fan in both cooling and heating mode (autofan function)

The autofan function allows the simultaneous ON/OFF control of the water valve and the fan, while at the same time optimising the operation of the unit. When reaching the set point, the controller closes the water valve (valve OFF) and only 3 minutes later stops the fan, so as to correctly compensate for the valve closing time. To prevent the air probe from measuring an incorrect temperature, when the fan is OFF the controller runs a number of fan ON cycles to annul the effect of any stratification of the air in the room.

In two pipe systems, a water probe (T2 accessory) can be installed on the supply pipe to the unit upstream of the water valve. Based on the temperature read in this section of the pipe, the device will select either cooling or heating operation.

The electronic board also features a contact for connection to a window switch or remote enabling signal. When the contact is closed, the unit can operate, when the contact is open, the unit stops. The same contact can be used for starting and stopping the unit from an external timer or any other remote switching device.

In addition, a series of units can be switched ON or OFF at the same time, by using a flip-flop switch connected to the terminals present on the board.

Sensors that require a 12 Volt power supply, for example occupancy sensors, can be connected to other terminals on the electronic board and then to the ON/OFF contacts. The board is able to power external sensors with a maximum current of 60 mA.

IRC
ELECTRONIC BOARD

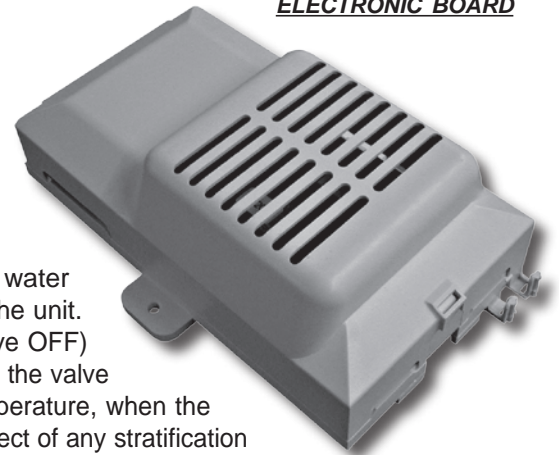

INSTALLATION EXAMPLE
WITH INFRA-RED REMOTE CONTROL

A group of Carisma units with IRC electronic board can be connected via a serial link and can consequently be managed at the same time by just one infra-red remote control or IRC-ETN wall mounted control. Using the special jumper present on the board, one unit must be configured as the master, and all the others as slaves. It is clear that the remote control must be pointed at the receiver on the master unit. To avoid problems, it is recommended to install and connect the receiver only on the master unit.

With infra-red remote control

One control for each unit



**One control for more units
(20 units max.)**

(MAXIMUM TOTAL LENGTH OF THE CONNECTION CABLE = 800 m)



With ETN

One control for each unit

(MAXIMUM LENGTH OF THE CONNECTION CABLE = 20 m)

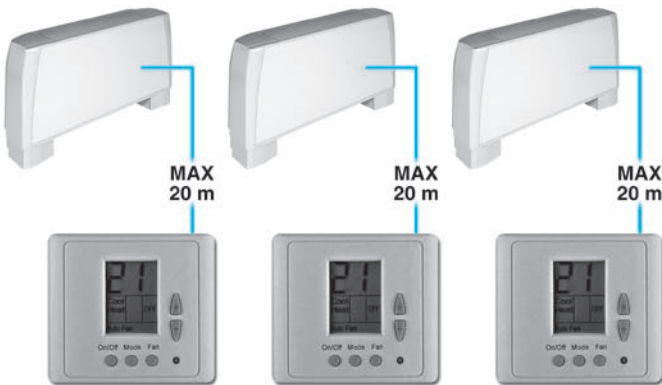

**One control for more units
(20 units max.)**

(MAXIMUM TOTAL LENGTH OF THE CONNECTION CABLE = 800 m)

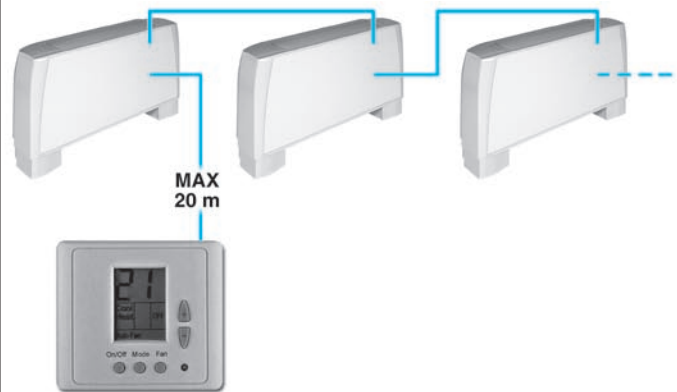

T2 Change-Over for infra-red remote control (accessory)

IDENTIFICATION	CODE
T2	9079103



Suitable for units with infra-red remote control only.

The NTC sensor, if connected to the T2 contact of the board, works like a change-over: fitted in contact to the supply pipe it controls automatically the winter/summer switch in accordance to the water temperature.

Multifunction control

Another option available for the serial communication between the units is the possibility to connect up to 60 Carisma units in series (the maximum length of the connection cable must not exceed 800 m) and manage them with just one wall-mounted intelligent PCR-DI controller. The wall-mounted controller can be used to set the operating mode for each individual unit connected, display the operating conditions of each individual unit, and set the ON/OFF time sets for each day of the week. If more than 60 units need to be connected, two or more wall-mounted intelligent controllers must be used. Each wall-mounted controller only manages the units it is connected to.

The PCR-DI control is used to manage a series of fan coils, up to a maximum of 60 units, from one single control point. The PCR-DI control communicates via a serial line with all the units connected, with the possibility of controlling them all together or individually. In fact, the unique address of each individual fan coil means that all the units can be called at the same time, or the individual unit called, to perform the following functions:

- display the current operating mode, the fan speed, the set point
- display the room temperature measured on the individual unit
- turn all the units ON and OFF at the same time or alternatively each unit individually
- change the operating mode (fan only, heating, cooling, automatic changeover)
- change the set point

Each function can then be sent to all the units connected, or alternatively to each individual unit.

Different set points or operating modes can be set for each individual unit.

The PCR-DI panel can also be used for the time management of the units over the week. Two on times and two off times can be set on the units for each day of the week.

The weekly programming mode can be stopped at any time, returning to the manual setting and then weekly programming mode can subsequently be started again.

IDENTIFICATION	CODE
PCR-DI	9079102

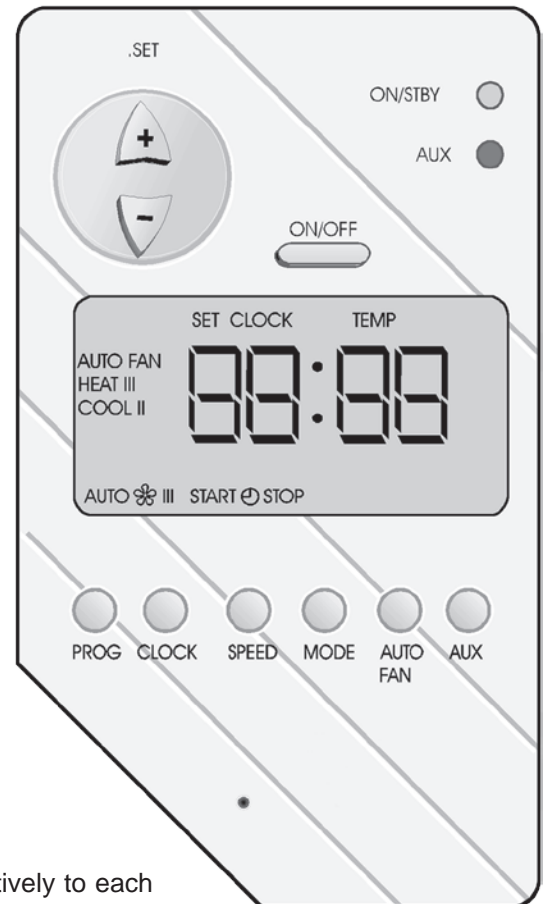

Maxinet program for managing a network of IR hydronic terminals

Maxinet is a centralised control system for networks of IR hydronic terminals, based on software that runs on Windows XP Professional Service Pack 2.

The Maxinet software offers a practical and economical solution for managing the terminals, with the simple click of the mouse.

The main characteristics include simplicity of use, an extremely complete and functional weekly program, and the possibility to access the historical operating data for each individual appliance connected.

The program exploits all the potential of our appliances with remote controls, representing an addition to the latter.

The Maxinet program is a control tool that can be used as a replacement for the remote control, or in parallel, however with the possibility of setting the priority, that is, the settings made using Maxinet can have priority over those made using the remote control.



The program can be used to:

- create uniform logical blocks (groups of units on individual floors, in offices or rooms).
- save weekly programs configured for different types of operation (summer, winter, mid seasons, closing periods etc.); these can then be recalled and activated with a simple click of the mouse. Weekly on/off cycles can be set for individual units or groups of units.
- set the operating conditions for each individual unit or groups of units (operating mode, fan speed, temperature setting).
- set the set point limits for each individual unit or groups of units.
- switch each individual unit or groups of units on or off.

The “Weekly Program” can be used to set the unit operating parameters for each day of the week. Up to 20 different weekly programs can be set.

Time bands are available for each day of the week.

The time and the type of operation to be performed by the unit can be set for each band.

The time and the operating parameters can then be displayed before being sent to the unit and implemented.

The screenshot shows the 'Edit Program Weekly Program' window. It includes a 'Program Name' field set to 'Weekly Program1', a 'Switch Program' dropdown, and a 'Program Is Disabled' checkbox. The main area is a 7x7 grid for configuring weekly programs. The first row shows time bands from 7:45 to 8:00, with 'On Heating 25' for Monday and 'On Heating 25' for the rest of the week. The second row shows 12:00 'Off' for all days. The third row shows 14:30 'On Heating 22' for all days. The fourth row shows 18:30 'Off' for all days. The right panel, 'Activation Status', shows 'Activating Day' as Monday, 'Activating Time' as 7:45:00, 'Turn Units' as 'On (or leave it on)', 'Mode' as 'Heating', 'Fan Speed' as 'Low', and 'Set Temperature' as 25. There are 'Delete' and 'Submit' buttons, and a 'Units To Activate' section with 'Floor PINNO 1: Whole Floor' selected and a 'Set Units' button.

One especially useful function of the weekly program is to have the program to carry out timed checking routines to identify whether the operating mode or temperature setting have been modified on the terminals, for example using the local remote control. If activated, the routine will reset all the unit operating parameters to the values set in the weekly program.

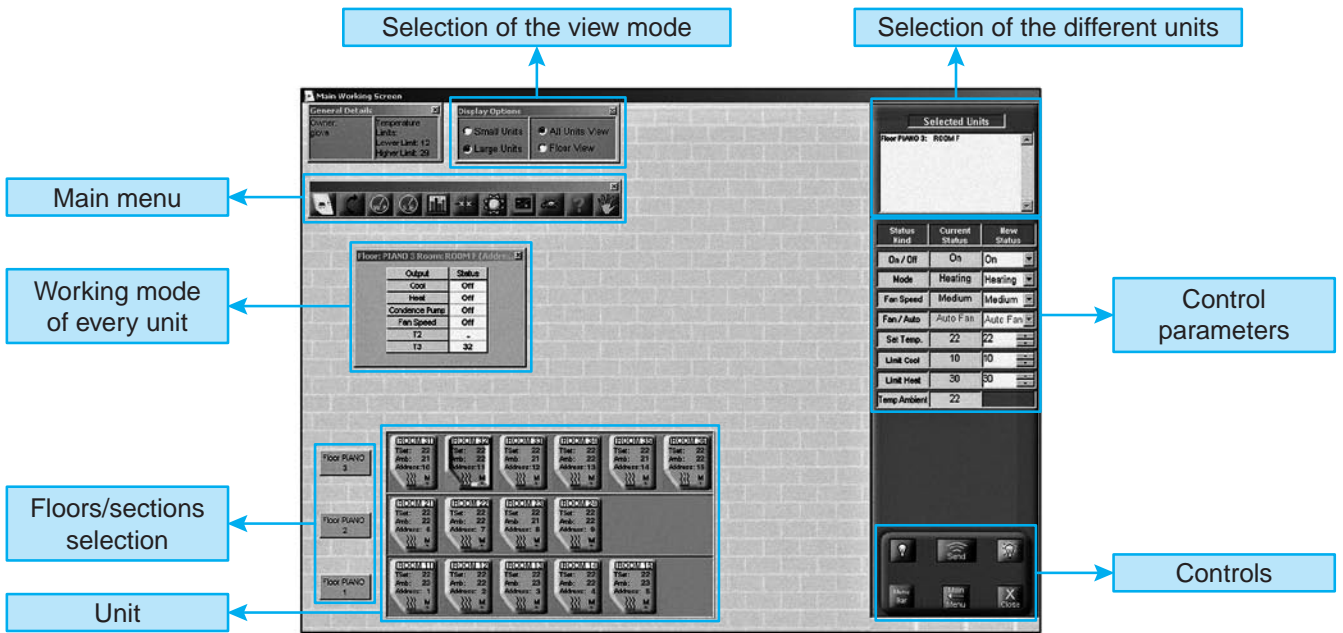

The main program screen can display and interact with the entire network of units. An individual unit, a group of units or the entire network can be called so as to make modifications to the operating mode and the set point. The user can then check the operating status of each individual unit, read the room temperature, the coil temperature and the operating status of the condensate drain pump or any alarms.

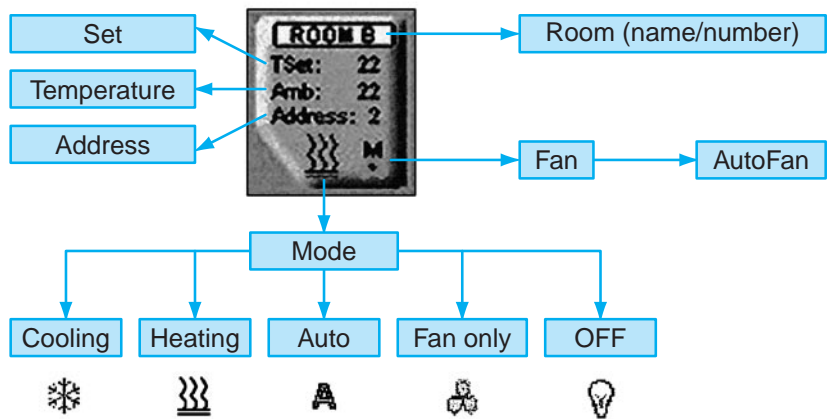

PC Maxinet Software

Connection of a Carisma network of more than 60 units

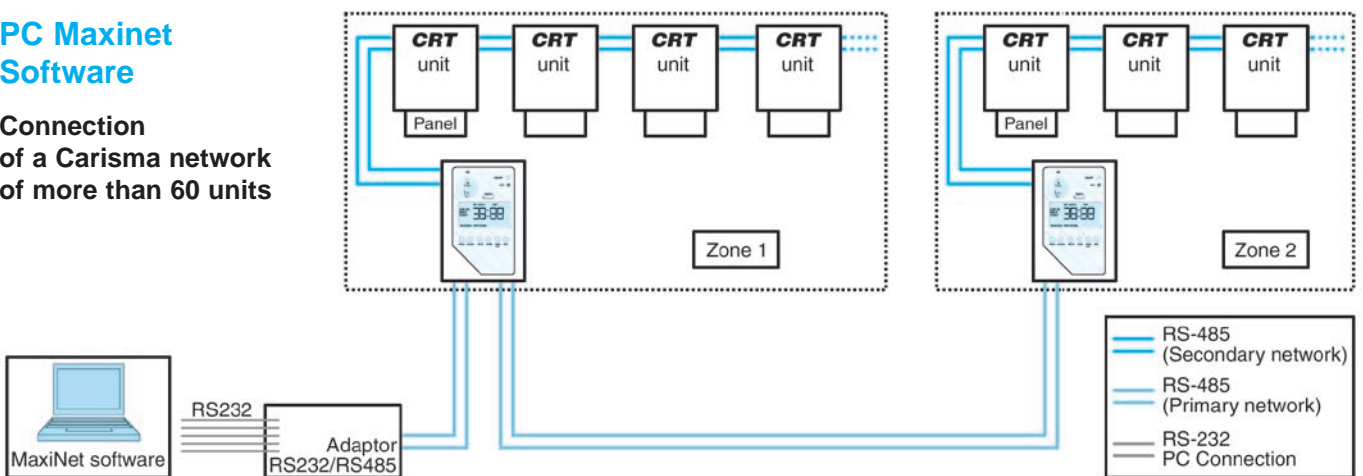

RS 485 serial connection cable

Shielded cable to be used:
Belden 9841, RS-485, 1x2x24 AWG SFTP, 120 Ohm



IDENTIFICATION	CODE
S08R	9079105

In addition to the air-conditioning units, MaxiNet can also work with general output cards.

Each card contains 8 outputs which can be connected to “On / Off” devices.

Inserting a new output card can be done through the regular units setting.

Handling the existing output cards is done through the output cards’ menu, which can be loaded from the working screen’s menu bar.

In the menu, choose the “General Outputs Cards” title.

The Out-Put card can be connected in a Maxinet network and controlled by the software. Up to 10 cards can be used.

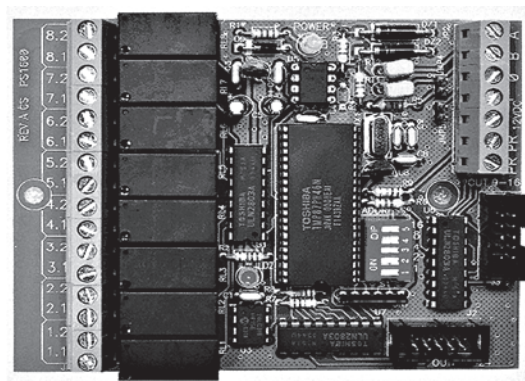

The descriptions and illustrations provided in this publication are not binding: Sabiana reserves the right, whilst maintaining the essential characteristics of the types described and illustrated, to make, at any time, without the requirement to promptly update this piece of literature, any changes that it considers useful for the purpose of improvement or for any other manufacturing or commercial requirements.

®



THE INTERNATIONAL CERTIFICATION NETWORK

CERTIFICATE

IQNet and its partner
CISQ/ICIM
hereby certify that the organization

SABIANA S.p.A.

Via Piave, 53 - I-20011 Corbetta (MI)

for the following field of activities

Design, production and service of heating and air conditioning equipment (unit heaters, radiant panels, fan coil units and air handling units) and chimneys.

has implemented and maintains a
Quality Management System

which fulfills the requirements of the following standard

ISO 9001:2008

Issued on: **2010-02-16**

Validity date: **2012-04-09**

Registration Number: **IT-4000**



René Wasmer

President of IQNET

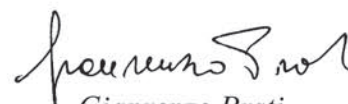
Gianrenzo Prati

President of CISQ

IQNet partners*:

AENOR Spain AFAQ AFNOR France AIB-Vinçotte International Belgium ANCE Mexico APCER Portugal CISQ Italy CQC China
CQM China CQS Czech Republic Cro Cert Croatia DQS Germany DS Denmark ELOT Greece FCAV Brazil
FONDONORMA Venezuela HKQAA Hong Kong China ICONTEC Colombia IMNC Mexico Inspecta Certification Finland
IRAM Argentina JQA Japan KFQ Korea MSZT Hungary Nemko AS Norway NSAI Ireland PCBC Poland QMI Canada
Quality Austria Austria RR Russia SAI Global Australia SII Israel SIQ Slovenia SIRIM QAS International Malaysia
SQS Switzerland SRAC Romania TEST St Petersburg Russia YUQS Serbia

IQNet is represented in the USA by: AFAQ AFNOR, AIB-Vinçotte International, CISQ, DQS, NSAI Inc., QMI and SAI Global

*The list of IQNet partners is valid at the time of issue of this certificate. Updated information is available under www.iqnet-certification.com



www.icim.it

CERTIFICATO n. 0545/4
CERTIFICATE No. _____

SI CERTIFICA CHE IL SISTEMA DI GESTIONE PER LA QUALITA' DI
WE HEREBY CERTIFY THAT THE QUALITY MANAGEMENT SYSTEM OPERATED BY

SABIANA S.p.A.

UNITA' OPERATIVE
OPERATIVE UNITS

Via Piave, 53 - 20011 Corbetta (MI)
Italia

E' CONFORME ALLA NORMA
IS IN COMPLIANCE WITH THE STANDARD

UNI EN ISO 9001:2008

PER LE SEGUENTI ATTIVITA'
FOR THE FOLLOWING ACTIVITIES

EA: 18

Progettazione, produzione e assistenza di apparecchiature per il riscaldamento e il condizionamento dell'aria (aerotermi, termostrisce radianti, ventilconvettori e unità trattamento aria) e canne fumarie.

Design, production and service of heating and air conditioning equipment (unit heaters, radiant panels, fan coil units and air handling units) and chimneys.

Riferirsi al Manuale della Qualità per l'applicabilità dei requisiti della norma di riferimento.
Refer to Quality Manual for details of application to reference standard requirements.

Il presente certificato è soggetto al rispetto del regolamento per la certificazione dei sistemi di gestione per la qualità delle aziende.
The use and the validity of this certificate shall satisfy the requirements of the rules for the certification of company quality management systems.

Data emissione
First issue
10/06/1996

Emissione corrente
Current issue
16/02/2010

Data di scadenza
Expiring date
09/04/2012

ICIM S.p.A.

Piazza Don Enrico Mapelli, 75 - 20099 Sesto San Giovanni (MI)

CISQ is a member of



www.iqnet-certification.com

IQNet, the association of the world's first class certification bodies, is the largest provider of management System Certification in the world. IQNet is composed of more than 30 bodies and counts over 150 subsidiaries all over the globe.

Il presente documento annulla e sostituisce il certificato di pari numero emesso in data 10/04/2009.

CISQ è la Federazione Italiana di Organismi di Certificazione dei sistemi di gestione aziendale

CISQ is the Italian Federation of management system Certification Bodies

SINERT

ACCREDITAMENTO ORGANISMI DI CERTIFICAZIONE E SPEDIZIONE

Membro degli Accordi di Mutuo Riconoscimento EA e IAF
Signatory of EA and IAF Mutual Recognition Agreements

SGQ N° 004A
SGA N° 005D
PRD N° 004B
SCR N° 006F



www.cisq.com

Air Conditioning
Carisma CRT Fan Coil Units



Sabiana s.p.a. • via Piave, 53 • 20011 Corbetta • Milano • Italy • phone +39.02.97203.1 r.a. / +39.02.97270429 / +39.02.97270576
fax +39.02.9777282 / +39.02.9772820 • www.sabiana.it • info@sabiana.it

CRT - EX - 03/11
Cod. A4670100 A/03/11