

Carisma

The Fan Coil Unit with
EC Brushless Electronic Motor
and Inverter Board

NEW
MB control board
for Modbus
communication protocol



Air Conditioning

CRC-ECM
Carisma CRT-ECM
CRS-ECM
Fan Coil Units



Quality management systems
ISO 9001 - Cert. n° 0545/5



www.eurovent-certification.com
www.certiflash.com



SABIANA
ENVIRONMENTAL COMFORT

Carisma fan coils combine a beautiful design with very interesting performances in terms of sound level and energy consumption.

Carisma ECM models are available in five different models, for wall and ceiling installation, with casing and concealed.

All Sabiana fan coils take part to the Eurovent program of fan coil performance certification.

The **ECM** range makes use of the excellent experience gained with the Cassette fan coils with inverter board, first in the world in production since 2009, and which have had great success on all markets.

The innovative brushless and sensorless type synchronous electronic motor with permanent magnets, is controlled by an **inverter** board designed and developed in Italy. The board is mounted on the unit, closed to the motor, without the need to be cooled down by the air flow.

The air flow rate can be varied in **continuous** by means of a 1-10 V signal generated by Sabiana controls or by independent control systems. The continuous air flow control improves the acoustic comfort and allows a more punctual reply to the variation of the thermal loads and a greater stability of the requested ambient temperature.

The extreme efficiency, also at low speed, makes possible a great reduction in electric consumption (less than 50% in comparison to CRC, CRT and CRS range motor) with absorption values under normal operating conditions that **do not exceed 16 Watt for CRC-ECM models, do not exceed 8 Watt for CRT-ECM models and do not exceed 50 Watt for CRS-ECM models** on the entire range. The excellent values of the CRC, CRT and CRS range in terms of sound levels have been maintained in **all working conditions**, without any resonance phenomenon at any frequency.

The full compliance with the Electromagnetic Compatibility Directive and with the other severe Standards in force is certified by an independent institute.

CONTENTS

• CRC-ECM version

- Construction Page 4
- Models Page 5
- Dimensions, Weight, Water content Page 6
- EUROVENT Certification Page 10
- Operation limits Page 13
- Emission tables Page 14
- Correction factors table Page 24
- Water pressure drop Page 25

• CRT-ECM version

- Construction Page 26
- Models Page 27
- Dimensions, Weight, Water content Page 28
- EUROVENT Certification Page 32
- Operation limits Page 34
- Emission tables Page 35
- Water pressure drop Page 43

• CRS-ECM version

- Construction features Page 44
- Dimensions, Weight, Water content Page 46
- EUROVENT Certification Page 48
- Main performance and technical characteristics Page 50
- Operation limits Page 51
- Emission tables Page 52
- Correction factors tables Page 58
- Water pressure drop Page 60

• CRC-ECM/CRT-ECM/CRS-ECM version

- Accessories Page 62
- **CRYSTALL** electrostatic filter Page 73
- **ECM** configuration Page 74
- Electronic controls Page 75
- Controls and units **MB version** Page 78
- Management system for a network of fan coils Page 83
- PSM-DI and Sabianet electronic boards Page 86

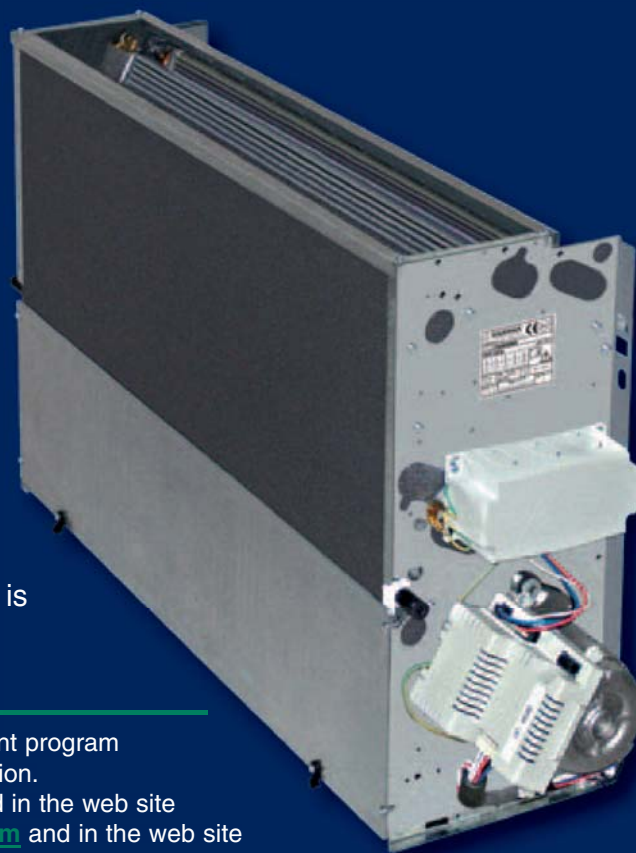

Sabiana take part to the Eurovent program of fan coil performance certification. The official figures are published in the web site www.eurovent-certification.com and in the web site www.certiflash.com. The tested performances are:

- | | |
|---|---|
| <ul style="list-style-type: none"> • Cooling total emission at the following conditions: <ul style="list-style-type: none"> - Water temperature +7°C E.W.T. +12°C L.W.T. - Entering air temperature +27°C dry bulb +19°C wet bulb • Heating emission (2 pipe units) at the following conditions: <ul style="list-style-type: none"> - Entering water temperature +50°C - Entering air temperature +20°C - <i>Water flow rate as for the cooling conditions</i> | <ul style="list-style-type: none"> • Cooling sensible emission at the following conditions: <ul style="list-style-type: none"> - Water temperature +7°C E.W.T. +12°C L.W.T. - Entering air temperature +27°C dry bulb +19°C wet bulb • Heating emission (4 pipe units) at the following conditions: <ul style="list-style-type: none"> - Water temperature +70°C E.W.T. +60°C L.W.T. - Entering air temperature +20°C |
|---|---|
- Fan absorption • Water pressure drop • Sound power

CRC-ECM version with centrifugal fan

Range includes 5 air flow rates (from 115 to 1395 m³/h) and 5 models (for wall and ceiling installation, with casing and concealed), each equipped with 3 or 4 row coil and with the possibility to add a 1 or 2 row coil for 4 pipe systems. It is the most comprehensive range, perfect to meet all air-conditioning requirements of work environments like offices, shops, restaurants and hotel rooms.

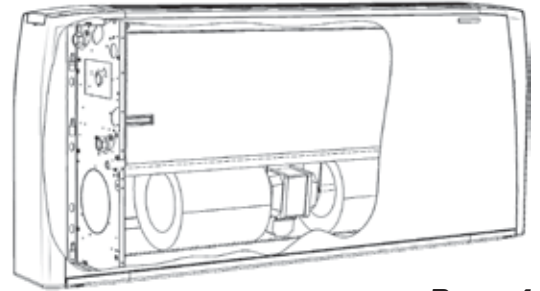

Page 4

CRT-ECM version with tangential fan

Range includes 5 air flow rates (from 95 to 900 m³/h) and 5 models (for wall and ceiling installation, with casing and concealed), each equipped with 3 row coil and with the possibility to add a 1 row coil for 4 pipe systems. It is the most comprehensive range, perfect to meet all air-conditioning requirements of work environments like offices, shops, restaurants and hotel rooms.

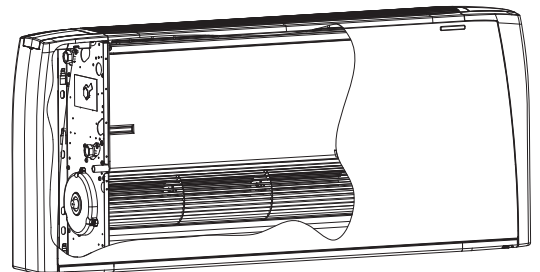

Page 26

CRS-ECM version with high pressure centrifugal fan

Range includes 3 air flow rates (from 350 to 1450 m³/h), each equipped with 3 or 4 row coil and with the possibility to add a 1 or 2 row coil for 4 pipe systems. It is the most comprehensive range, perfect to meet all air-conditioning requirements of work environments like offices, shops, restaurants and hotel rooms featuring ducted installations with available pressure up to 80 Pa.



Page 44

CRC-ECM and CRT-ECM version

**Plastic outlet grid
in one single piece:
extraordinary
design and strength**



Construction

Outer casing

Made from strong synthetic lateral corners and from galvanized and prepainted frontal steel sheet. The plastic top grid has fixed louvres and is reversible in order to distribute the air in two different directions.

Standard colours:

- Lateral corners and top grid: **Pantone Cool Grey 1C (light grey)**
- Frontal sheet: **RAL 9003 (white)**
- Other colours on request.

Inner casing

Made from 1 mm galvanized steel insulated with polyolefin (PO) foam (class M1).

Filter

Polypropylene cellular fabric regenerating filter. The filter frame of galvanized steel is inserted into special plastic sliding guides fastened to the internal structure for easy insertion and removal of the filter. Filter presence is highlighted by a plastic front cover featuring the same colour as the top grid.



Fan assembly

The fans have aluminium or plastic blades directly keyed on the motor with double aspiration and they are dynamically and statically balanced during manufacture in order to have an extremely quiet operation.

Electronic motor

Three phase permanent magnet brushless electronic motor that is controlled with reconstructed current according to a BLAC sinusoidal wave. The inverter board that controls the motor operation is powered by 230 Volt, single-phase and, with a switching system, it generates a three-phase frequency modulated, wave form power supply. The electric power supply required for the machine is therefore single-phase with voltage of 230-240V and frequency of 50-60Hz.

Coil

It is manufactured from drawn copper tube and the aluminium fins are mechanically bonded onto the tube by an expansion process. The coil has two 1/2 inch BSP internal connections and 1/8 inch BSP air vent and drain. The coil is not suitable for use in corrosive atmosphere or in environments where aluminium may be subject to corrosion.

The connections are on the left side facing the unit. On request we can deliver the unit with the connections on the right end side. This operation can also be easily carried out on site during installation.

Condensate collection tray

Made from plastic (ABS UL94 HB) with an "L"-shape fitted on the inner casing; in the MO-MVB and IV-IO model the tray is insulated with polyolefin (PO) foam (class M1). The outside diameter of the condensate discharge pipe is 15mm.

Accessories and Controls

See page 62 and 75.

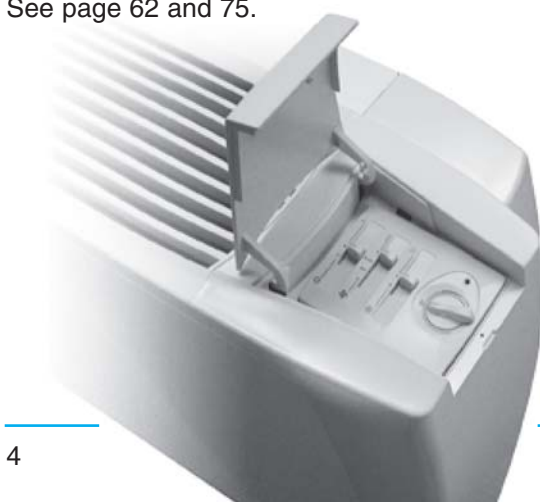

Models

MV

Vertical Casing – Wall Installation

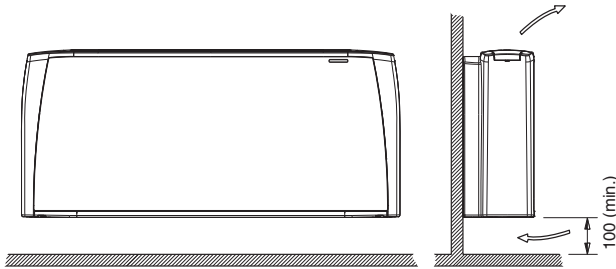

MV

Vertical Casing – Ceiling Installation

NOTE: the MV model can also be installed horizontally leaving behind a 100 mm gap for air intake.

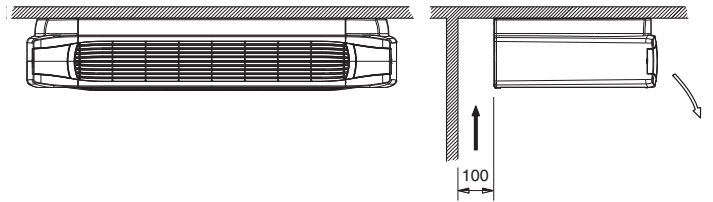

MO-MVB

Vertical Casing – Floor Installation

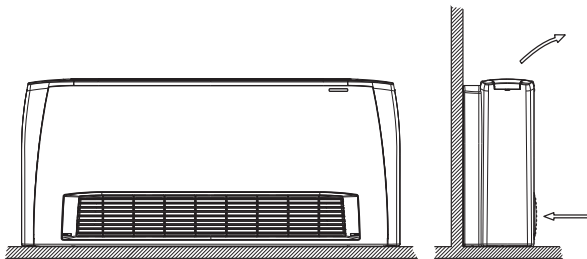

MO-MVB

Horizontal Casing

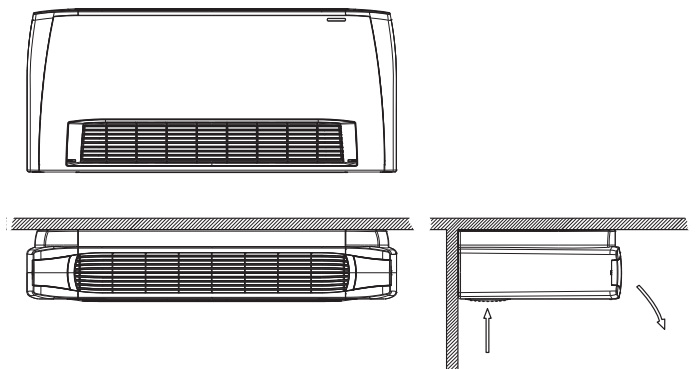

IV-IO

Vertical Concealed

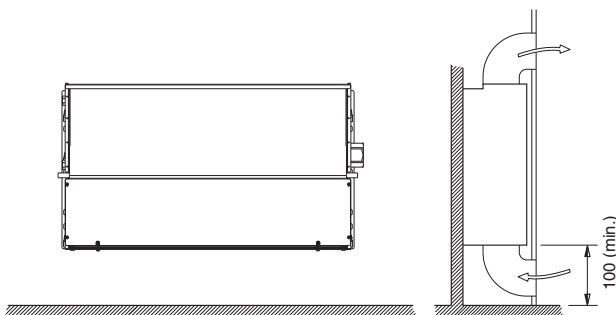

IV-IO

Horizontal Concealed

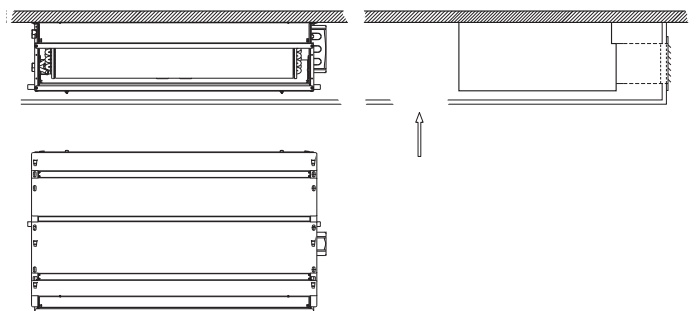

Dimensions, Weight, Water content

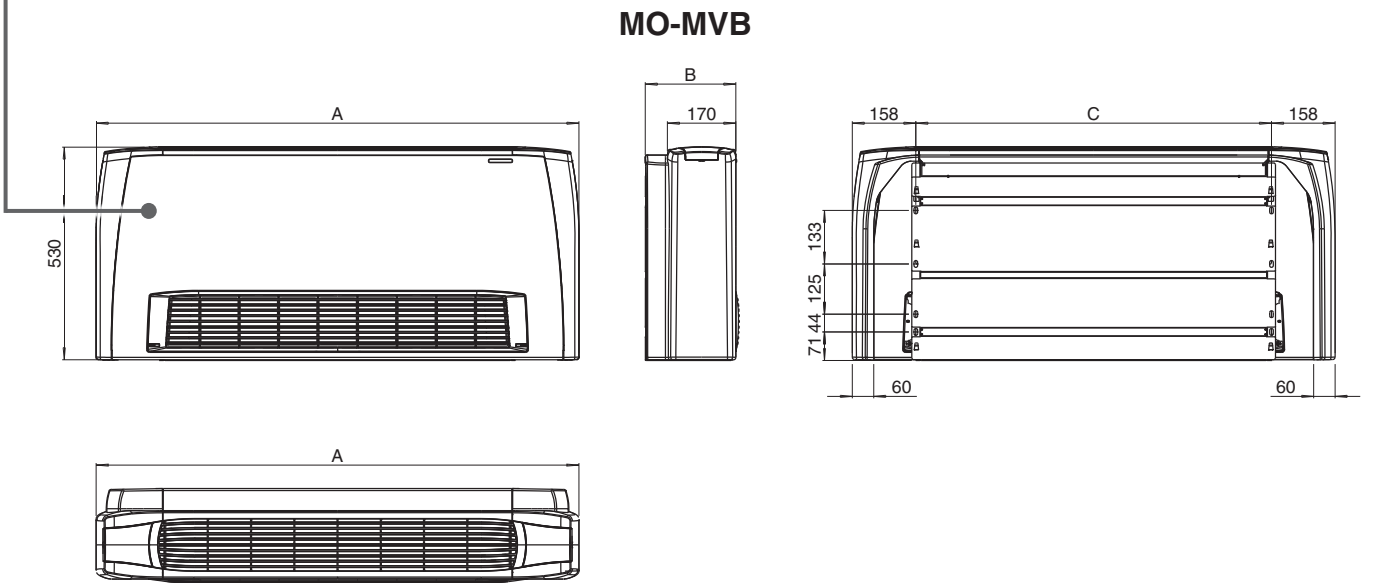
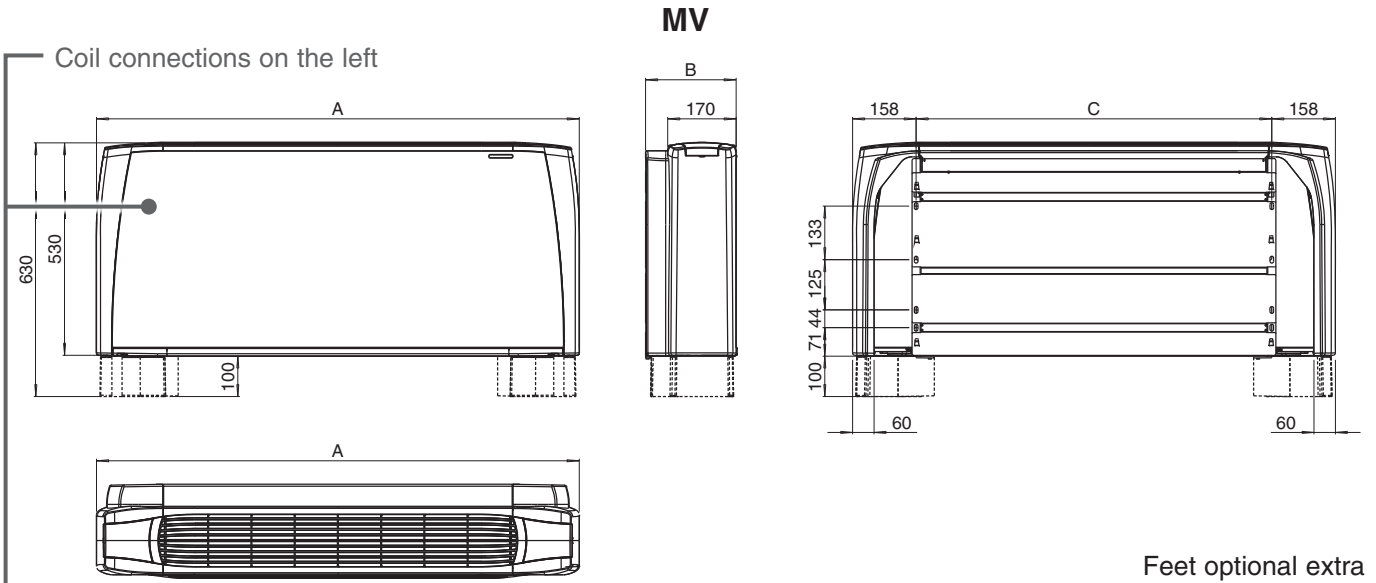

COIL CONNECTIONS

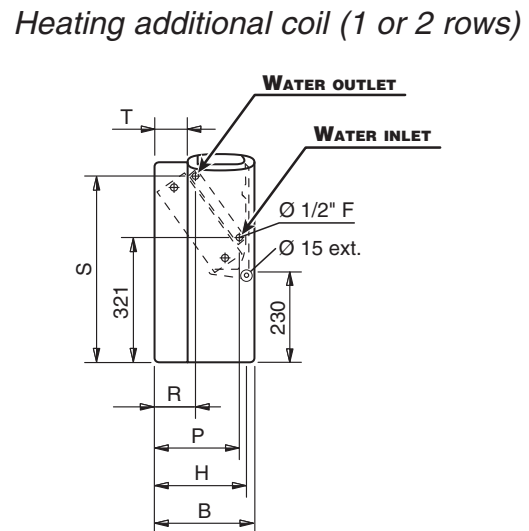
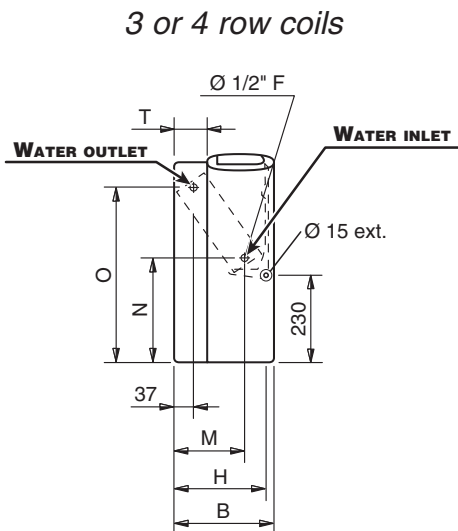

Dimensions, Weight, Water content

PACKAGING

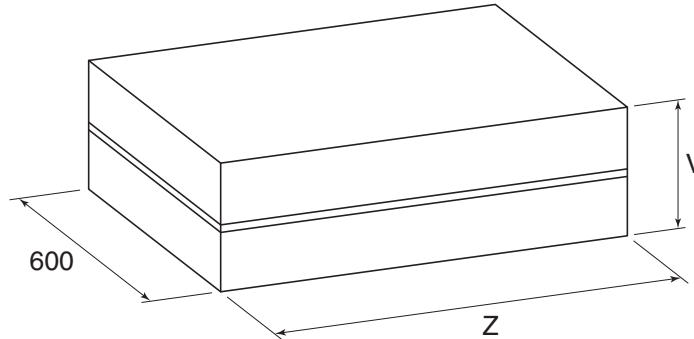

Dimensions (mm)

MODEL	2	4	6	7	9
A	770	985	1200	1415	1415
B	225	225	225	225	255
C	454	669	884	1099	1099
H	205	205	205	205	235
M	145	145	145	145	170
N	260	260	260	260	270
O	460	460	460	460	450
P	185	185	185	185	210
R	105	105	105	105	110
S	475	475	475	475	465
T	55	55	55	55	85
V	260	260	260	260	290
Z	820	1035	1250	1465	1465

Weight (kg)

		Weight with packaging					Weight without packaging				
MODEL		2	4	6	7	9	2	4	6	7	9
Rows	3	16	22	25	30	40	14	19	22	26	36
	3+1	19	28	31	37	48	17	25	28	33	44
	3+2	22	34	37	44	56	20	31	34	40	52
	4	18	25	28	34	46	16	22	25	30	42
	4+1	21	30	33	40	54	19	27	30	36	50

Water content (litres)

MODEL	2	4	6	7	9
3	0,6	0,9	1,6	1,7	1,9
4	0,8	1,3	2,2	2,4	2,8
+1	0,2	0,3	0,5	0,5	0,6
+2	0,4	0,6	1,0	1,0	1,2

Dimensions, Weight, Water content

IV-IO Vertical Installation

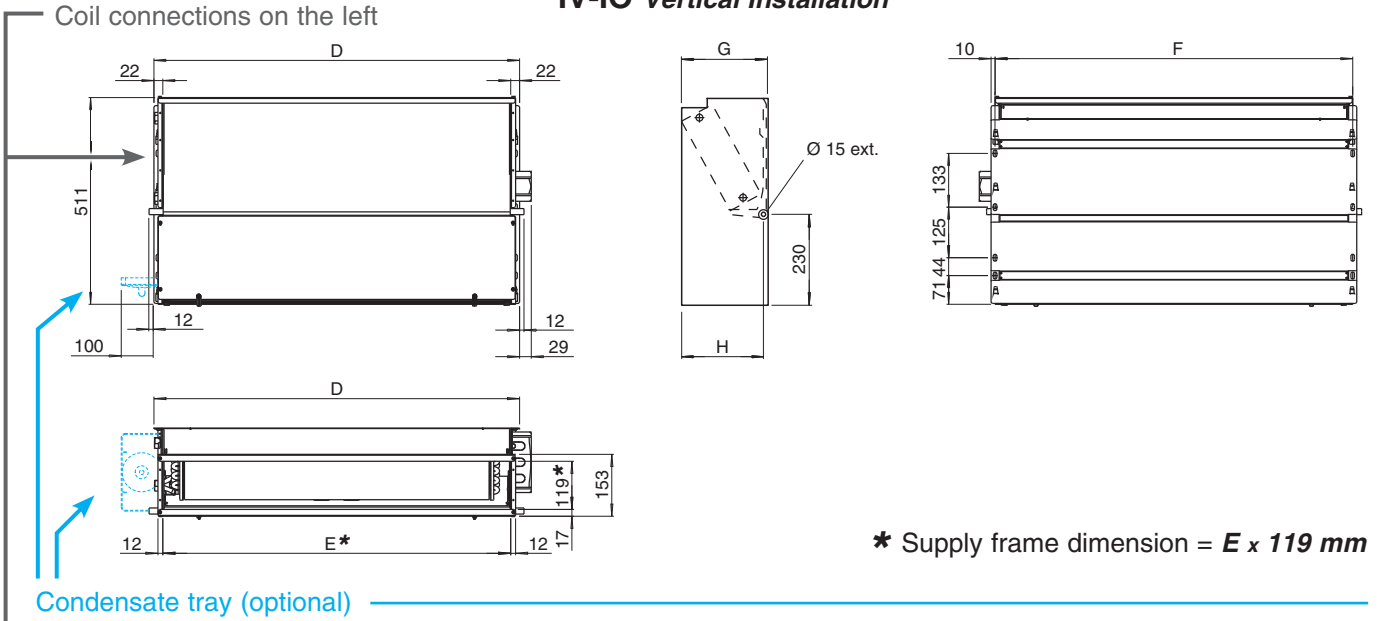

IV-IO Horizontal Installation

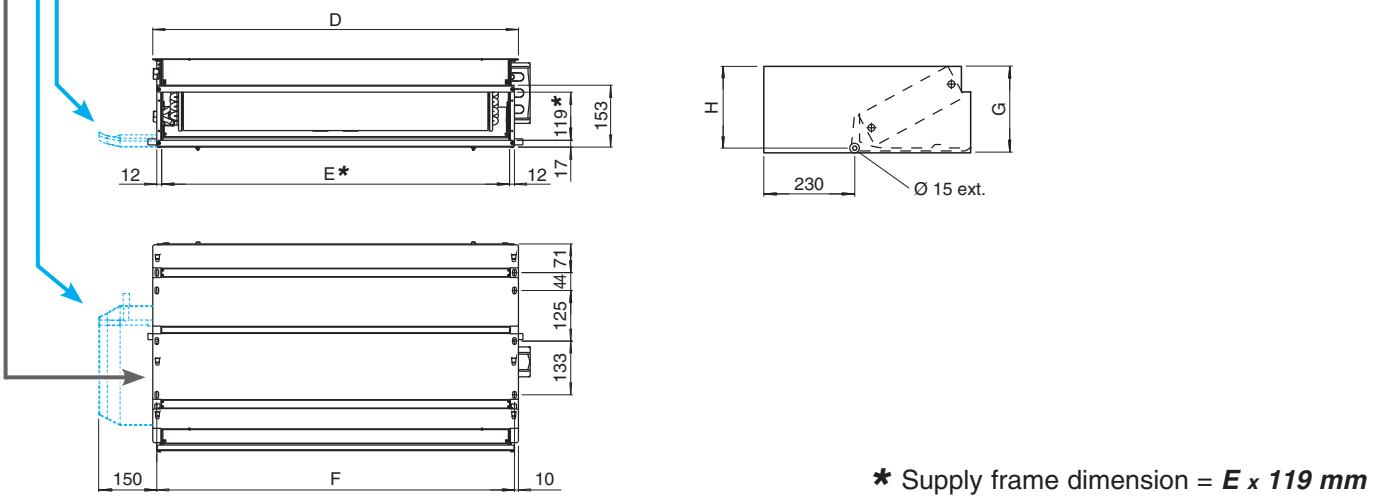

COIL CONNECTIONS

3 or 4 row coils

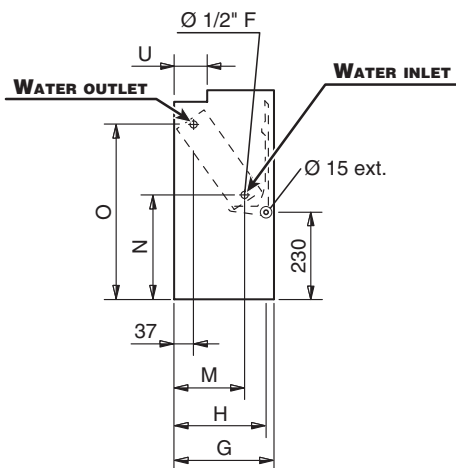

Heating additional coil (1 or 2 rows)

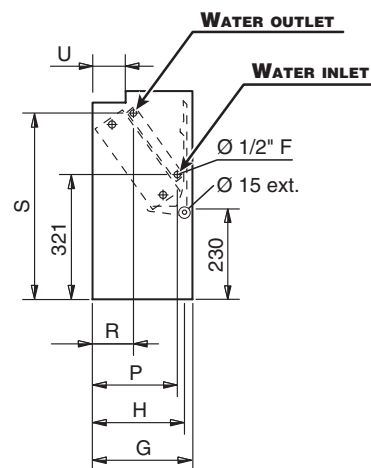

Dimensions, Weight, Water content

PACKAGING

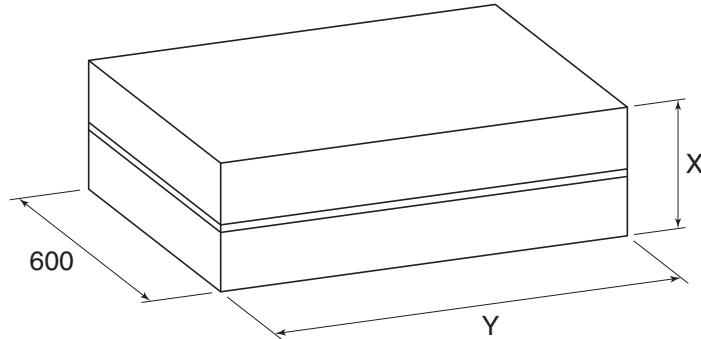

Dimensions (mm)

MODEL	2	4	6	7	9
<i>D</i>	474	689	904	1119	1119
<i>E</i>	430	645	860	1075	1075
<i>F</i>	454	669	884	1099	1099
<i>G</i>	218	218	218	218	248
<i>H</i>	205	205	205	205	235
<i>M</i>	145	145	145	145	170
<i>N</i>	260	260	260	260	270
<i>O</i>	460	460	460	460	450
<i>P</i>	185	185	185	185	210
<i>R</i>	105	105	105	105	110
<i>S</i>	475	475	475	475	465
<i>U</i>	65	65	65	65	95
<i>X</i>	260	260	260	260	290
<i>Y</i>	820	820	1035	1250	1250

Weight (kg)

		<i>Weight with packaging</i>					<i>Weight without packaging</i>				
MODEL		2	4	6	7	9	2	4	6	7	9
<i>Rows</i>	<i>3</i>	15	20	23	27	36	13	19	22	25	33
	<i>3+1</i>	17	26	29	34	44	16	24	27	31	41
	<i>3+2</i>	20	32	35	41	52	19	29	32	37	49
	<i>4</i>	17	23	26	31	42	15	21	24	28	39
	<i>4+1</i>	20	28	31	37	50	18	26	29	34	47

Water content (litres)

MODEL	2	4	6	7	9
<i>3</i>	0,6	0,9	1,6	1,7	1,9
<i>4</i>	0,8	1,3	2,2	2,4	2,8
<i>+1</i>	0,2	0,3	0,5	0,5	0,6
<i>+2</i>	0,4	0,6	1,0	1,0	1,2

CRC-ECM UNITS WITH 3 ROW COIL

2 pipe units.

The following standard rating conditions are used:

COOLING

Entering air temperature +27°C d.b. +19°C w.b.
Water temperature + 7°C E.W.T. +12°C L.W.T.

HEATING

Entering air temperature +20°C
Entering water temperature +50°C
Water flow rate as for the cooling conditions

MODEL	CRC-ECM 23					CRC-ECM 43					CRC-ECM 63					
	1 (E)	3	5 (E)	7,5	10 (E)	1 (E)	3	5 (E)	7,5	10 (E)	1 (E)	3	5 (E)	7,5	10 (E)	
Inverter power																
Speed	MIN		MED		MAX	MIN		MED		MAX	MIN		MED		MAX	
Air flow	m ³ /h	120	170	220	270	330	210	280	350	430	515	305	395	495	610	735
Cooling total emission (E)	kW	0,74	0,98	1,19	1,39	1,61	1,42	1,80	2,19	2,58	2,97	1,97	2,45	2,94	3,46	3,99
Cooling sensible emission (E)	kW	0,56	0,75	0,93	1,10	1,30	1,04	1,34	1,65	1,96	2,28	1,47	1,84	2,23	2,67	3,11
Heating (E)	kW	0,92	1,24	1,53	1,81	2,13	1,70	2,20	2,70	3,21	3,74	2,35	2,96	3,59	4,25	4,95
Dp Cooling (E)	kPa	1,8	2,9	4,0	5,3	6,9	7,9	12,0	17,0	22,6	28,9	5,5	8,0	11,1	14,8	19,0
Dp Heating (E)	kPa	1,4	2,5	3,4	4,5	5,7	6,6	9,9	13,8	18,2	23,9	4,5	6,7	9,2	12,1	15,7
Fan (E)	W	7,0	9,0	11,0	14,5	21,0	6,0	9,0	12,0	17,0	25,0	7,0	10,0	15,0	22,0	32,0
Sound power (E)	Lw dB(A)	30	36	41	47	51	30	36	42	47	51	33	38	44	49	54
Sound pressure (*)	Lp dB(A)	21	27	32	38	42	21	27	33	38	42	24	29	35	40	45

MODEL	CRC-ECM 73					CRC-ECM 93					
	1 (E)	3	5 (E)	7,5	10 (E)	1 (E)	3	5 (E)	7,5	10 (E)	
Inverter power											
Speed	MIN		MED		MAX	MIN		MED		MAX	
Air flow	m ³ /h	400	500	610	755	890	605	785	945	1175	1395
Cooling total emission (E)	kW	2,61	3,14	3,70	4,39	4,98	3,47	4,25	4,86	5,67	6,36
Cooling sensible emission (E)	kW	1,93	2,35	2,79	3,35	3,84	2,65	3,31	3,83	4,56	5,20
Heating (E)	kW	3,08	3,76	4,47	5,32	6,09	4,45	5,53	6,41	7,62	8,69
Dp Cooling (E)	kPa	10,5	14,5	19,4	26,1	32,6	8,9	12,7	16,1	21,1	25,9
Dp Heating (E)	kPa	8,4	11,9	16,1	21,5	26,8	7,7	11,0	13,9	18,3	22,5
Fan (E)	W	9,0	13	18,5	28,5	41,0	16,0	25,0	41,0	65,0	99,0
Sound power (E)	Lw dB(A)	37	43	48	53	57	44	50	55	60	64
Sound pressure (*)	Lp dB(A)	28	34	39	44	48	35	41	46	51	55

(E) = Eurovent certified performance.

(*) = The sound pressure levels are 9 dB(A) lower than the sound power levels and apply to the reverberant field of a 100 m³ room and a reverberation time of 0.5 sec.

EUROVENT Certification

CRC-ECM UNITS WITH 4 ROW COIL

2 pipe units.

The following standard rating conditions are used:

COOLING

Entering air temperature +27°C d.b. +19°C w.b.
Water temperature + 7°C E.W.T. +12°C L.W.T.

HEATING

Entering air temperature +20°C
Entering water temperature +50°C
Water flow rate as for the cooling conditions

MODEL		CRC-ECM 24					CRC-ECM 44					CRC-ECM 64				
		1 (E)	3	5 (E)	7,5	10 (E)	1 (E)	3	5 (E)	7,5	10 (E)	1 (E)	3	5 (E)	7,5	10 (E)
Speed		MIN		MED		MAX	MIN		MED		MAX	MIN		MED		MAX
Air flow	m³/h	115	160	210	260	325	200	265	340	415	505	290	375	475	590	720
Cooling total emission (E)	kW	0,78	1,07	1,33	1,59	1,88	1,44	1,84	2,28	2,73	3,19	2,06	2,61	3,20	3,86	4,54
Cooling sensible emission (E)	kW	0,57	0,79	0,99	1,20	1,44	1,04	1,35	1,68	2,04	2,41	1,49	1,90	2,35	2,86	3,41
Heating (E)	kW	0,94	1,30	1,63	1,98	2,37	1,70	2,19	2,75	3,31	3,91	2,43	3,12	3,87	4,71	5,60
Dp Cooling (E)	kPa	3,2	5,5	8,0	11,0	14,8	4,0	6,1	8,9	12,2	16,1	8,2	12,4	17,8	24,8	33,0
Dp Heating (E)	kPa	2,6	4,6	6,5	9,1	12,6	3,0	4,8	7,2	10,0	13,5	6,5	10,2	14,9	20,4	26,9
Fan (E)	W	7,0	9,0	11,0	14,5	21,0	6,0	9,0	12,0	17,0	25,0	7,0	10,0	15,0	22,0	32,0
Sound power (E)	Lw dB(A)	30	36	41	47	51	30	36	42	47	51	33	38	44	49	54
Sound pressure (*)	Lp dB(A)	21	27	32	38	42	21	27	33	38	42	24	29	35	40	45

MODEL		CRC-ECM 74					CRC-ECM 94				
		1 (E)	3	5 (E)	7,5	10 (E)	1 (E)	3	5 (E)	7,5	10 (E)
Speed		MIN		MED		MAX	MIN		MED		MAX
Air flow	m³/h	380	475	585	735	875	575	755	910	1145	1365
Cooling total emission (E)	kW	2,62	3,21	3,84	4,64	5,34	3,61	4,52	5,25	6,25	7,14
Cooling sensible emission (E)	kW	1,91	2,36	2,84	3,47	4,03	2,71	3,43	4,03	4,87	5,63
Heating (E)	kW	3,09	3,82	4,61	5,61	6,51	4,50	5,73	6,70	8,12	9,39
Dp Cooling (E)	kPa	7,3	10,5	14,3	20,0	25,6	6,3	9,3	12,1	16,5	20,8
Dp Heating (E)	kPa	6,0	8,5	11,8	16,7	21,0	5,2	7,7	9,9	13,5	17,0
Fan (E)	W	9,0	13,0	18,5	28,5	41,0	16,0	25,0	41,0	65,0	99,0
Sound power (E)	Lw dB(A)	37	43	48	53	57	44	50	55	60	64
Sound pressure (*)	Lp dB(A)	28	34	39	44	48	35	41	46	51	55

(E) = Eurovent certified performance.

(*) = The sound pressure levels are 9 dB(A) lower than the sound power levels and apply to the reverberant field of a 100 m³ room and a reverberation time of 0.5 sec.

CRC-ECM UNITS WITH 1 ROW ADDITIONAL COIL

4 pipe units.

The following standard rating conditions are used:

COOLING

Entering air temperature +27°C d.b. +19°C w.b.
Water temperature +7°C E.W.T. +12°C L.W.T.

HEATING

Entering air temperature +20°C
Water temperature +70°C E.W.T. +60°C L.W.T.

MODEL		CRC-ECM 23+1					CRC-ECM 43+1					CRC-ECM 63+1				
Inverter power		1 (E)	3	5 (E)	7,5	10 (E)	1 (E)	3	5 (E)	7,5	10 (E)	1 (E)	3	5 (E)	7,5	10 (E)
Speed		MIN		MED		MAX	MIN		MED		MAX	MIN		MED		MAX
Air flow	m ³ /h	120	170	220	270	330	210	280	350	430	515	305	395	495	610	735
Cooling total emission (E)	kW	0,74	0,98	1,19	1,39	1,61	1,42	1,80	2,19	2,58	2,97	1,97	2,45	2,94	3,46	3,99
Cooling sensible emission (E)	kW	0,56	0,75	0,93	1,10	1,30	1,04	1,34	1,65	1,96	2,28	1,47	1,84	2,23	2,67	3,11
Heating (E)	kW	0,81	1,04	1,23	1,42	1,63	1,47	1,79	2,11	2,42	2,74	2,00	2,40	2,80	3,24	3,68
Dp Cooling (E)	kPa	1,8	2,9	4,0	5,3	6,9	7,9	12,0	17,0	22,6	28,9	5,5	8,0	11,1	14,8	19,0
Dp Heating (E)	kPa	1,3	1,9	2,6	3,4	4,3	4,5	6,4	8,5	10,9	13,6	1,5	2,1	2,8	3,6	4,5
Fan (E)	W	7,0	9,0	11,0	14,5	21,0	6,0	9,0	12,0	17,0	25,0	7,0	10,0	15,0	22,0	32,0
Sound power (E)	Lw dB(A)	30	36	41	47	51	30	36	42	47	51	33	38	44	49	54
Sound pressure (*)	Lp dB(A)	21	27	32	38	42	21	27	33	38	42	24	29	35	40	45

MODEL		CRC-ECM 73+1					CRC-ECM 93+1				
Inverter power		1 (E)	3	5 (E)	7,5	10 (E)	1 (E)	3	5 (E)	7,5	10 (E)
Speed		MIN		MED		MAX	MIN		MED		MAX
Air flow	m ³ /h	400	500	610	755	890	605	785	945	1175	1395
Cooling total emission (E)	kW	2,61	3,14	3,70	4,39	4,98	3,47	4,25	4,86	5,67	6,36
Cooling sensible emission (E)	kW	1,93	2,35	2,79	3,35	3,84	2,65	3,31	3,83	4,56	5,20
Heating (E)	kW	2,65	3,10	3,56	4,13	4,63	3,40	4,08	4,62	5,35	5,98
Dp Cooling (E)	kPa	10,5	14,5	19,4	26,1	32,6	8,9	12,7	16,1	21,1	25,9
Dp Heating (E)	kPa	2,9	3,9	4,9	6,4	7,8	4,6	6,3	7,8	10,1	12,3
Fan (E)	W	9,0	13,0	18,5	28,5	41,0	16,0	25,0	41,0	65,0	99,0
Sound power (E)	Lw dB(A)	37	43	48	53	57	44	50	55	60	64
Sound pressure (*)	Lp dB(A)	28	34	39	44	48	35	41	46	51	55

(E) = Eurovent certified performance.

(*) = The sound pressure levels are 9 dB(A) lower than the sound power levels and apply to the reverberant field of a 100 m³ room and a reverberation time of 0.5 sec.

Operation limits

Highest water inlet temperature..... + 85 °C

Lowest water inlet temperature..... + 5 °C

for entering water temperatures below + 5°C, contact “SABIANA” technical department

Highest working pressure..... 1000 kPa (10 bars)

Note: For MO model the maximum installation height is 2,8 m.

On heating it must be payed attention to rooms where the floor temperature is particularly low (for example less than 5°C).

In this situation the floor can cool the lower layer of air to a level that can stop the uniform diffusion of the hot air coming from the unit.

Water flow limits for 3 row coil (l/h)

MODEL	CRC-ECM 23	CRC-ECM 43	CRC-ECM 63	CRC-ECM 73	CRC-ECM 93
Lowest	100	100	150	150	200
Highest	500	750	1000	1500	2000

Water flow limits for 4 row coil (l/h)

MODEL	CRC-ECM 24	CRC-ECM 44	CRC-ECM 64	CRC-ECM 74	CRC-ECM 94
Lowest	100	150	150	200	300
Highest	750	1000	1500	2000	2250

Water flow limits for 1 row additional coil (l/h)

MODEL	CRC-ECM 2	CRC-ECM 4	CRC-ECM 6	CRC-ECM 7	CRC-ECM 9
Lowest	50	50	100	100	100
Highest	250	350	500	650	750

Water flow limits for 2 row additional coil (l/h)

MODEL	CRC-ECM 2	CRC-ECM 4	CRC-ECM 6	CRC-ECM 7	CRC-ECM 9
Lowest	50	100	100	100	100
Highest	250	350	500	650	750

Motor electrical data (max. absorption)

MODEL	CRC-ECM 2	CRC-ECM 4	CRC-ECM 6	CRC-ECM 7	CRC-ECM 9	
230/1 50Hz	W	20,5	25,0	32,0	41,0	99,0

Cooling emission of 3 row coil

Entering air temperature: 27°C – R.H.: 50%

MODEL ECM	Vdc	WT: 7/12 °C					WT: 8/13 °C					WT: 10/15 °C					WT: 12/17 °C				
		Qv m³/h	Pc kW	Ps kW	Qw l/h	Dp(c) kPa	Pc kW	Ps kW	Qw l/h	Dp(c) kPa	Pc kW	Ps kW	Qw l/h	Dp(c) kPa	Pc kW	Ps kW	Qw l/h	Dp(c) kPa			
CRC 23	10	330	1,74	1,29	299	7,9	1,55	1,21	266	6,4	1,14	1,06	196	3,7	0,92	0,92	159	2,5			
	7,5	270	1,50	1,10	258	6,1	1,34	1,03	230	4,9	0,99	0,90	171	2,9	0,79	0,79	135	1,9			
	5	220	1,28	0,92	220	4,6	1,14	0,87	196	3,7	0,85	0,75	147	2,2	0,67	0,67	115	1,4			
	3	170	1,05	0,75	181	3,3	0,94	0,70	162	2,7	0,71	0,61	121	1,6	0,54	0,54	93	1,0			
	1	120	0,80	0,56	137	2,0	0,72	0,52	123	1,6	0,54	0,46	93	1,0	0,40	0,40	69	0,6			
CRC 43	10	515	3,20	2,27	550	32,9	2,86	2,14	493	27	2,17	1,87	373	16,3	1,65	1,65	283	9,9			
	7,5	430	2,78	1,96	478	25,8	2,49	1,84	429	21,2	1,89	1,60	326	12,8	1,42	1,42	243	7,6			
	5	350	2,36	1,64	406	19,3	2,12	1,55	365	15,9	1,62	1,35	278	9,7	1,19	1,19	204	5,6			
	3	280	1,94	1,34	334	13,7	1,75	1,26	300	11,3	1,33	1,09	229	6,9	0,97	0,97	167	3,9			
	1	210	1,52	1,04	262	8,9	1,37	0,98	236	7,4	1,05	0,85	181	4,6	0,75	0,75	129	2,5			
CRC 63	10	735	4,29	3,10	738	21,6	3,84	2,92	661	17,6	2,89	2,55	498	10,6	2,25	2,25	386	6,7			
	7,5	610	3,73	2,66	641	16,8	3,34	2,50	574	13,8	2,52	2,18	434	8,3	1,92	1,92	331	5,1			
	5	495	3,16	2,23	544	12,6	2,84	2,09	488	10,3	2,15	1,83	370	6,3	1,61	1,61	277	3,7			
	3	395	2,63	1,84	453	9,1	2,37	1,72	407	7,5	1,80	1,50	310	4,6	1,33	1,33	229	2,7			
	1	305	2,12	1,46	365	6,3	1,91	1,38	329	5,2	1,46	1,20	251	3,2	1,06	1,06	182	1,8			
CRC 73	10	890	5,36	3,83	921	37,1	4,08	3,60	702	30,4	3,65	3,15	627	18,5	2,78	2,78	478	11,3			
	7,5	755	4,72	3,34	812	29,7	4,24	3,14	729	24,4	3,22	2,74	555	14,9	2,42	2,42	416	8,8			
	5	610	3,98	2,78	684	22	3,58	2,62	615	18,1	2,73	2,28	470	11,1	2,01	2,01	346	6,4			
	3	500	3,38	2,34	581	16,5	3,04	2,20	523	13,6	2,33	1,92	400	8,4	1,70	1,70	292	4,8			
	1	400	2,80	1,92	482	11,9	2,52	1,81	434	9,8	1,94	1,57	333	6,1	1,39	1,39	240	3,4			
CRC 93	10	1395	6,86	5,16	1180	25,4	6,11	4,86	1051	20,6	4,53	4,27	780	12	3,73	3,73	642	8,4			
	7,5	1175	6,11	4,53	1051	20,7	5,45	4,27	938	16,8	4,06	3,74	698	9,9	3,27	3,27	563	6,7			
	5	945	5,23	3,81	900	15,8	4,68	3,59	804	12,8	3,50	3,14	602	7,6	2,75	2,75	474	4,9			
	3	785	4,58	3,29	787	12,4	4,09	3,10	704	10,2	3,08	2,71	529	6,1	2,38	2,38	409	3,8			
	1	605	3,73	2,65	642	8,7	3,34	2,49	575	7,1	2,52	2,17	434	4,3	1,92	1,92	330	2,6			

Correction factors for different R.H.

R.H.	WT:	7/12°C	8/13°C	10/15°C	12/17°C
48%	Pc	0,95	0,94	1,00	1,00
	Ps	1,00	1,00	1,00	1,00
46%	Pc	0,90	0,88	1,00	1,00
	Ps	1,00	1,00	1,00	1,00

LEGEND

- WT = Water temperature
- Pc = Cooling total emission
- Ps = Cooling sensible emission
- Qw = Water flow
- Dp(c) = Water pressure drop
- Vdc = Inverter Power
- Qv = Air flow

Cooling emission of 3 row coil

Entering air temperature: 26°C – R.H.: 50%

MODEL ECM	Vdc	WT: 7/12 °C					WT: 8/13 °C					WT: 10/15 °C					WT: 12/17 °C				
		Qv	Pc	Ps	Qw	Dp(c)	Pc	Ps	Qw	Dp(c)	Pc	Ps	Qw	Dp(c)	Pc	Ps	Qw	Dp(c)			
		m³/h	kW	kW	l/h	kPa	kW	kW	l/h	kPa	kW	kW	l/h	kPa	kW	kW	l/h	kPa			
CRC 23	10	330	1,54	1,21	265	6,4	1,35	1,14	232	5,0	1,01	1,01	173	3,0	0,84	0,84	145	2,1			
	7,5	270	1,33	1,03	229	4,9	1,17	0,97	201	3,9	0,86	0,86	147	2,2	0,72	0,72	123	1,6			
	5	220	1,14	0,87	195	3,7	1,00	0,81	172	3,0	0,70	0,70	121	1,6	0,61	0,61	105	1,2			
	3	170	0,94	0,70	161	2,7	0,82	0,66	142	2,1	0,58	0,56	100	1,1	0,49	0,49	85	0,8			
	1	120	0,71	0,53	122	1,6	0,63	0,49	108	1,3	0,45	0,42	77	0,7	0,37	0,37	63	0,5			
CRC 43	10	515	2,85	2,14	490	26,9	2,52	2,01	433	21,5	1,81	1,73	311	11,8	1,51	1,51	259	8,5			
	7,5	430	2,48	1,84	426	21,1	2,19	1,73	377	16,9	1,58	1,49	272	9,4	1,30	1,30	223	6,5			
	5	350	2,11	1,55	362	15,8	1,88	1,45	323	12,7	1,36	1,25	233	7,1	1,09	1,09	187	4,8			
	3	280	1,73	1,26	298	11,2	1,54	1,18	265	9,0	1,12	1,01	193	5,1	0,89	0,89	153	3,3			
	1	210	1,36	0,98	234	7,3	1,21	0,92	208	5,9	0,89	0,79	153	3,4	0,69	0,69	118	2,1			
CRC 63	10	735	3,82	2,92	658	17,6	3,37	2,74	580	14	2,40	2,36	413	7,6	2,05	2,05	353	5,7			
	7,5	610	3,32	2,50	571	13,7	2,93	2,35	504	11	2,10	2,02	361	6,0	1,76	1,76	302	4,3			
	5	495	2,82	2,10	485	10,3	2,49	1,96	429	8,2	1,80	1,69	309	4,6	1,47	1,47	253	3,2			
	3	395	2,35	1,73	404	7,5	2,08	1,62	358	6,0	1,51	1,39	260	3,4	1,22	1,22	209	2,3			
	1	305	1,90	1,38	326	5,1	1,68	1,29	289	4,1	1,23	1,11	211	2,3	0,97	0,97	167	1,5			
CRC 73	10	890	4,78	3,61	822	30,4	4,23	3,38	727	24,3	3,04	2,92	523	13,4	2,54	2,54	437	9,7			
	7,5	755	4,22	3,15	725	24,3	3,73	2,95	642	19,5	2,70	2,54	464	10,9	2,21	2,21	381	7,6			
	5	610	3,56	2,62	611	18	3,15	2,55	542	14,5	2,29	2,12	394	8,2	1,84	1,84	317	5,5			
	3	500	3,02	2,21	520	13,6	2,68	2,07	462	10,9	1,96	1,78	337	6,2	1,56	1,56	268	4,1			
	1	400	2,51	1,81	431	9,8	2,23	1,70	383	7,9	1,64	1,46	281	4,5	1,28	1,28	220	2,9			
CRC 93	10	1395	6,09	4,87	1048	20,6	5,35	4,57	920	16,3	4,06	4,06	699	9,9	3,40	3,40	585	7,1			
	7,5	1175	5,43	4,27	934	16,8	4,77	4,01	821	13,3	3,56	3,56	613	7,8	2,99	2,99	513	5,7			
	5	945	4,66	3,60	801	12,8	4,10	3,37	705	10,2	3,00	3,00	515	5,8	2,51	2,51	432	4,2			
	3	785	4,07	3,10	700	10,1	3,59	2,91	617	8,1	2,55	2,50	438	4,3	2,17	2,17	373	3,2			
	1	605	3,33	2,49	572	7,1	2,94	2,33	505	5,7	2,10	2,01	361	3,1	1,75	1,75	302	2,2			

Correction factors for different R.H.

R.H.	WT:	7/12°C	8/13°C	10/15°C	12/17°C
48%	Pc	0,95	0,94	1,00	1,00
	Ps	1,00	1,00	1,00	1,00
46%	Pc	0,90	0,88	1,00	1,00
	Ps	1,00	1,00	1,00	1,00

LEGEND

- WT = Water temperature
- Pc = Cooling total emission
- Ps = Cooling sensible emission
- Qw = Water flow
- Dp(c) = Water pressure drop
- Vdc = Inverter Power
- Qv = Air flow

Cooling emission of 3 row coil

Entering air temperature: 25°C – R.H.: 50%

MODEL ECM	Vdc	WT: 7/12 °C					WT: 8/13 °C				WT: 10/15 °C				WT: 12/17 °C			
		Qv m³/h	Pc kW	Ps kW	Qw l/h	Dp(c) kPa	Pc kW	Ps kW	Qw l/h	Dp(c) kPa	Pc kW	Ps kW	Qw l/h	Dp(c) kPa	Pc kW	Ps kW	Qw l/h	Dp(c) kPa
CRC 23	10	330	1,35	1,14	232	5,0	1,15	1,06	198	3,8	0,93	0,92	159	2,5	0,76	0,76	131	1,8
	7,5	270	1,17	0,97	200	3,9	1,00	0,90	172	3,0	0,79	0,79	135	1,9	0,65	0,65	111	1,3
	5	220	1,00	0,81	171	3,0	0,86	0,76	147	2,3	0,67	0,67	115	1,4	0,55	0,55	94	1,0
	3	170	0,82	0,66	141	2,1	0,71	0,61	122	1,6	0,54	0,54	93	1,0	0,45	0,45	77	0,7
	1	120	0,63	0,49	108	1,3	0,54	0,46	93	1,0	0,40	0,40	69	0,6	0,33	0,33	57	0,4
CRC 43	10	515	2,51	2,01	432	21,6	2,18	1,87	375	16,7	1,65	1,65	284	10,1	1,36	1,36	235	7,1
	7,5	430	2,19	1,73	376	16,9	1,90	1,61	327	13,1	1,42	1,42	244	7,7	1,17	1,17	202	5,5
	5	350	1,86	1,45	320	12,7	1,62	1,35	278	9,9	1,19	1,19	205	5,7	0,99	0,99	170	4,0
	3	280	1,53	1,18	264	9,0	1,34	1,10	230	7,1	0,97	0,97	168	4,0	0,81	0,81	139	2,8
	1	210	1,21	0,92	207	5,9	1,05	0,85	181	4,6	0,75	0,75	130	2,5	0,63	0,63	108	1,8
CRC 63	10	735	3,37	2,74	579	14,1	2,91	2,56	501	10,8	2,25	2,25	387	6,8	1,86	1,86	319	4,8
	7,5	610	2,93	2,35	503	11	2,54	2,19	436	8,5	1,93	1,93	331	5,2	1,59	1,59	274	3,6
	5	495	2,49	1,97	428	8,3	2,16	1,83	371	6,4	1,61	1,61	277	3,8	1,33	1,33	229	2,7
	3	395	2,08	1,62	357	6,0	1,81	1,51	310	4,7	1,34	1,34	230	2,7	1,11	1,11	190	1,9
	1	305	1,68	1,29	288	4,1	1,46	1,20	251	3,2	1,06	1,06	183	1,8	0,88	0,88	151	1,3
CRC 73	10	890	4,22	3,39	726	24,4	3,67	3,16	631	18,9	2,78	2,78	479	11,5	2,30	2,30	396	8,1
	7,5	755	3,72	2,96	640	19,6	3,24	2,76	557	15,2	2,43	2,43	417	9,0	2,01	2,01	345	6,4
	5	610	3,14	2,46	541	14,5	2,74	2,29	471	11,3	2,02	2,02	347	6,5	1,67	1,67	287	4,6
	3	500	2,67	2,07	460	10,9	2,33	1,93	401	8,5	1,71	1,71	293	4,9	1,41	1,41	243	3,4
	1	400	2,22	1,70	382	7,9	1,94	1,58	334	6,2	1,34	1,40	230	3,4	1,16	1,16	200	2,4
CRC 93	10	1395	5,35	4,58	920	16,4	4,59	4,28	789	12,4	3,73	3,73	642	8,5	3,07	3,07	528	6,0
	7,5	1175	4,77	4,01	820	13,4	4,10	3,74	706	10,2	3,28	3,28	563	6,8	2,70	2,70	464	4,7
	5	945	4,09	3,37	703	10,2	3,53	3,15	607	7,8	2,76	2,76	474	5,0	2,27	2,27	391	3,5
	3	785	3,58	2,91	616	8,1	3,09	2,71	532	6,2	2,38	2,38	409	3,9	1,96	1,96	337	2,7
	1	605	2,93	2,34	503	5,7	2,54	2,18	436	4,4	1,92	1,92	331	2,6	1,59	1,59	273	1,9

Correction factors for different R.H.

R.H.	WT:	7/12°C	8/13°C	10/15°C	12/17°C
48%	Pc	0,95	0,94	1,00	1,00
	Ps	1,00	1,00	1,00	1,00
46%	Pc	0,90	0,88	1,00	1,00
	Ps	1,00	1,00	1,00	1,00

LEGEND

- WT = Water temperature
- Pc = Cooling total emission
- Ps = Cooling sensible emission
- Qw = Water flow
- Dp(c) = Water pressure drop
- Vdc = Inverter Power
- Qv = Air flow

Cooling emission of 4 row coil

Entering air temperature: 27°C – R.H.: 50%

MODEL ECM	Vdc	WT: 7/12 °C					WT: 8/13 °C					WT: 10/15 °C					WT: 12/17 °C				
		Qv	Pc	Ps	Qw	Dp(c)	Pc	Ps	Qw	Dp(c)	Pc	Ps	Qw	Dp(c)	Pc	Ps	Qw	Dp(c)			
		m³/h	kW	kW	l/h	kPa	kW	kW	l/h	kPa	kW	kW	l/h	kPa	kW	kW	l/h	kPa			
CRC 24	10	325	2,02	1,44	348	16,9	1,81	1,35	312	13,8	1,37	1,18	235	8,3	1,04	1,04	179	5,0			
	7,5	260	1,71	1,20	294	12,5	1,53	1,13	264	10,3	1,16	0,98	200	6,2	0,87	0,87	149	3,7			
	5	210	1,43	0,99	245	9,1	1,28	0,93	220	7,5	0,97	0,81	168	4,6	0,72	0,72	123	2,6			
	3	160	1,15	0,79	197	6,2	1,03	0,74	178	5,1	0,79	0,65	136	3,1	0,57	0,57	98	1,8			
	1	115	0,84	0,57	145	3,6	0,76	0,54	131	3,0	0,58	0,47	100	1,9	0,41	0,41	71	1,0			
CRC 44	10	505	3,44	2,40	592	18,5	3,09	2,26	531	15,2	2,34	1,96	403	9,2	1,74	1,74	299	5,4			
	7,5	415	2,94	2,03	506	14	2,64	1,91	454	11,5	2,01	1,66	346	7,0	1,47	1,47	253	4,0			
	5	340	2,45	1,68	421	10,1	2,20	1,58	379	8,4	1,68	1,37	290	5,1	1,21	1,21	208	2,8			
	3	265	1,98	1,35	340	7,0	1,78	1,26	307	5,8	1,37	1,10	235	3,6	0,97	0,97	167	1,9			
	1	200	1,54	1,04	266	4,5	1,40	0,98	240	3,7	1,08	0,85	185	2,3	0,75	0,75	129	1,2			
CRC 64	10	720	4,88	3,40	839	37,4	4,39	3,19	755	30,9	3,35	2,78	577	19	2,46	2,46	423	10,8			
	7,5	590	4,14	2,86	713	28,1	3,73	2,69	642	23,2	2,86	2,34	492	14,3	2,07	2,07	356	8,0			
	5	475	3,43	2,35	590	20,2	3,10	2,21	533	16,7	2,38	1,92	409	10,4	1,70	1,70	293	5,7			
	3	375	2,80	1,90	481	14,1	2,53	1,79	434	11,7	1,95	1,55	335	7,3	1,37	1,37	236	3,9			
	1	290	2,20	1,49	379	9,2	1,99	1,40	343	7,7	1,54	1,22	265	4,8	1,07	1,07	184	2,5			
CRC 74	10	875	5,74	4,02	987	29,1	5,16	3,78	888	24	3,94	3,30	677	14,7	2,91	2,91	501	8,5			
	7,5	735	4,98	3,46	857	22,7	4,49	3,25	771	18,7	3,43	2,84	590	11,5	2,50	2,50	431	6,5			
	5	585	4,13	2,84	710	16,3	3,72	2,67	639	13,5	2,85	2,32	491	8,3	2,06	2,06	354	4,6			
	3	475	3,45	2,36	593	11,9	3,11	2,21	535	9,8	2,39	1,93	412	6,1	1,70	1,70	293	3,3			
	1	380	2,81	1,91	484	8,3	2,54	1,79	437	6,9	1,96	1,56	337	4,3	1,38	1,38	237	2,3			
CRC 94	10	1365	7,70	5,60	1324	23,7	6,87	5,27	1182	19,3	5,14	4,61	883	11,4	4,04	4,04	695	7,4			
	7,5	1145	6,74	4,85	1160	18,8	6,03	4,56	1037	15,3	4,52	3,98	778	9,1	3,50	3,50	602	5,7			
	5	910	5,65	4,01	972	13,8	5,06	3,77	871	11,3	3,81	3,29	656	6,8	2,89	2,89	497	4,1			
	3	755	4,87	3,42	837	10,6	4,36	3,21	750	8,7	3,30	2,80	567	5,2	2,48	2,48	426	3,1			
	1	575	3,89	2,70	669	7,1	3,49	2,54	601	5,9	2,65	2,21	456	3,6	1,95	1,95	335	2,0			

Correction factors for different R.H.

R.H.	WT:	7/12°C	8/13°C	10/15°C	12/17°C
48%	Pc	0,95	0,94	1,00	1,00
	Ps	1,00	1,00	1,00	1,00
46%	Pc	0,90	0,88	1,00	1,00
	Ps	1,00	1,00	1,00	1,00

LEGEND

- WT = Water temperature
- Pc = Cooling total emission
- Ps = Cooling sensible emission
- Qw = Water flow
- Dp(c) = Water pressure drop
- Vdc = Inverter Power
- Qv = Air flow

Cooling emission of 4 row coil

Entering air temperature: 26°C – R.H.: 50%

MODEL ECM	Vdc	WT: 7/12 °C					WT: 8/13 °C					WT: 10/15 °C					WT: 12/17 °C				
		Qv m³/h	Pc kW	Ps kW	Qw l/h	Dp(c) kPa	Pc kW	Ps kW	Qw l/h	Dp(c) kPa	Pc kW	Ps kW	Qw l/h	Dp(c) kPa	Pc kW	Ps kW	Qw l/h	Dp(c) kPa			
CRC 24	10	325	1,80	1,35	310	13,8	1,59	1,27	273	11	1,14	1,09	195	6,0	0,95	0,95	163	4,3			
	7,5	260	1,52	1,13	262	10,2	1,35	1,06	232	8,2	0,97	0,91	166	4,5	0,79	0,79	136	3,1			
	5	210	1,27	0,93	219	7,5	1,13	0,87	194	6,0	0,82	0,75	140	3,3	0,66	0,66	113	2,3			
	3	160	1,03	0,75	176	5,1	0,91	0,70	157	4,1	0,66	0,60	114	2,3	0,52	0,52	90	1,5			
	1	115	0,75	0,54	130	3,0	0,67	0,51	115	2,4	0,49	0,43	85	1,4	0,38	0,38	65	0,9			
CRC 44	10	505	3,07	2,26	528	15,1	2,72	2,11	467	12,1	1,96	1,82	338	6,8	1,59	1,59	274	4,6			
	7,5	415	2,63	1,92	452	11,5	2,33	1,79	400	9,2	1,69	1,54	291	5,2	1,35	1,35	232	3,4			
	5	340	2,19	1,58	376	8,3	1,94	1,48	334	6,7	1,42	1,27	244	3,8	1,11	1,11	191	2,4			
	3	265	1,77	1,27	304	5,7	1,57	1,18	271	4,6	1,15	1,01	198	2,6	0,89	0,89	153	1,7			
	1	200	1,38	0,98	238	3,7	1,23	0,92	212	3,0	0,91	0,79	156	1,7	0,69	0,69	119	1,1			
CRC 64	10	720	4,36	3,20	750	30,8	3,87	3,00	666	24,7	2,82	2,58	486	14	2,25	2,25	388	9,3			
	7,5	590	3,71	2,70	638	23,1	3,29	2,52	567	18,6	2,41	2,17	415	10,6	1,90	1,90	326	6,9			
	5	475	3,08	2,21	529	16,6	2,74	2,07	470	13,4	2,01	1,78	346	7,7	1,56	1,56	268	4,9			
	3	375	2,51	1,79	431	11,6	2,23	1,67	384	9,4	1,65	1,44	283	5,4	1,26	1,26	217	3,3			
	1	290	1,98	1,40	340	7,6	1,77	1,31	304	6,2	1,31	1,13	225	3,6	0,98	0,98	169	2,2			
CRC 74	10	875	5,13	3,79	883	23,9	4,55	3,55	782	19,2	3,31	3,06	569	10,8	2,67	2,67	459	7,3			
	7,5	735	4,46	3,26	766	18,6	3,96	3,05	680	15	2,89	2,63	497	8,5	2,29	2,29	394	5,6			
	5	585	3,69	2,68	635	13,4	3,28	2,50	565	10,8	2,41	2,15	414	6,2	1,89	1,89	325	4,0			
	3	475	3,09	2,22	531	9,8	2,75	2,08	473	7,9	2,02	1,79	348	4,5	1,56	1,56	269	2,8			
	1	380	2,52	1,80	434	6,8	2,25	1,68	387	5,6	1,66	1,45	286	3,2	1,26	1,26	217	2,0			
CRC 94	10	1365	6,84	5,28	1177	19,3	6,02	4,95	1035	15,3	4,40	4,40	757	8,7	3,69	3,69	635	6,3			
	7,5	1145	6,00	4,57	1031	15,3	5,28	4,28	908	12,1	3,74	3,68	643	6,5	3,19	3,19	549	4,9			
	5	910	5,03	3,78	866	11,2	4,44	3,54	764	8,9	3,16	3,04	544	4,9	2,64	2,64	454	3,5			
	3	755	4,33	4,00	745	8,6	3,83	3,01	659	6,9	2,74	2,59	472	3,8	2,27	2,27	390	2,7			
	1	575	3,47	2,54	597	5,8	3,07	2,38	528	4,7	2,22	2,04	382	2,6	1,78	1,78	307	1,7			

Correction factors for different R.H.

R.H.	WT:	7/12°C	8/13°C	10/15°C	12/17°C
48%	Pc	0,95	0,94	1,00	1,00
	Ps	1,00	1,00	1,00	1,00
46%	Pc	0,90	0,88	1,00	1,00
	Ps	1,00	1,00	1,00	1,00

LEGEND

- WT = Water temperature
- Pc = Cooling total emission
- Ps = Cooling sensible emission
- Qw = Water flow
- Dp(c) = Water pressure drop
- Vdc = Inverter Power
- Qv = Air flow

Cooling emission of 4 row coil

Entering air temperature: 25°C – R.H.: 50%

MODEL ECM	Vdc	WT: 7/12 °C					WT: 8/13 °C					WT: 10/15 °C					WT: 12/17 °C				
		Qv	Pc	Ps	Qw	Dp(c)	Pc	Ps	Qw	Dp(c)	Pc	Ps	Qw	Dp(c)	Pc	Ps	Qw	Dp(c)			
		m³/h	kW	kW	l/h	kPa	kW	kW	l/h	kPa	kW	kW	l/h	kPa	kW	kW	l/h	kPa			
CRC 24	10	325	1,59	1,27	273	11	1,37	1,18	236	8,5	1,04	1,04	179	5,1	0,86	0,86	148	3,6			
	7,5	260	1,34	1,06	231	8,2	1,16	0,99	200	6,3	0,87	0,87	149	3,7	0,72	0,72	123	2,6			
	5	210	1,12	0,88	193	6,0	0,98	0,81	168	4,6	0,72	0,72	124	2,7	0,60	0,60	103	1,9			
	3	160	0,91	0,70	156	4,1	0,79	0,65	136	3,2	0,57	0,57	99	1,8	0,47	0,47	82	1,3			
	1	115	0,67	0,51	115	2,4	0,58	0,47	100	1,9	0,40	0,40	68	0,9	0,34	0,34	59	0,7			
CRC 44	10	505	2,71	2,12	466	12,1	2,35	1,97	405	9,4	1,74	1,74	300	5,5	1,43	1,44	246	3,9			
	7,5	415	2,32	1,79	399	9,2	2,02	1,67	347	7,2	1,48	1,48	254	4,1	1,22	1,22	210	2,9			
	5	340	1,94	1,48	333	6,7	1,69	1,38	290	5,2	1,22	1,22	209	2,9	1,01	1,01	174	2,1			
	3	265	1,57	1,19	269	4,6	1,37	1,10	235	3,6	0,93	0,93	160	1,8	0,81	0,81	139	1,4			
	1	200	1,23	0,92	211	3,0	1,08	0,86	185	2,4	0,74	0,72	127	1,2	0,63	0,63	108	0,9			
CRC 64	10	720	3,86	3,00	664	24,8	3,36	2,80	578	19,3	2,47	2,47	424	11,1	2,05	2,05	352	7,8			
	7,5	590	3,28	2,53	565	18,6	2,87	2,35	493	14,6	2,08	2,08	357	8,1	1,72	1,72	296	5,8			
	5	475	2,72	2,08	469	13,4	2,38	1,93	410	10,5	1,71	1,71	294	5,8	1,42	1,42	244	4,1			
	3	375	2,22	1,68	382	9,4	1,95	1,56	335	7,4	1,34	1,32	230	3,8	1,14	1,15	196	2,8			
	1	290	1,76	1,32	302	6,2	1,54	1,12	265	4,9	1,07	1,03	184	2,5	0,90	0,90	154	1,8			
CRC 74	10	875	4,54	3,56	780	19,2	3,95	3,32	679	15	2,92	2,92	502	8,7	2,42	2,42	416	6,1			
	7,5	735	3,94	3,06	678	15	3,44	2,85	591	11,7	2,51	2,51	432	6,7	2,08	2,08	358	4,7			
	5	585	3,27	2,51	562	10,8	2,86	2,34	491	8,5	2,07	2,07	356	4,7	1,71	1,71	295	3,4			
	3	475	2,74	2,08	471	7,9	2,39	1,94	412	6,2	1,63	1,63	281	3,1	1,42	1,42	244	2,4			
	1	380	2,24	1,69	385	5,5	1,96	1,57	337	4,4	1,35	1,32	232	2,2	1,15	1,15	198	1,7			
CRC 94	10	1365	6,01	4,96	1033	15,3	5,18	4,62	891	11,7	4,05	4,05	696	7,5	3,33	3,33	573	5,3			
	7,5	1145	5,27	4,29	906	12,2	4,55	3,99	783	9,3	3,50	3,50	603	5,8	2,89	2,89	497	4,1			
	5	910	4,43	3,54	762	9,0	3,83	3,30	659	6,9	2,90	2,90	498	4,2	2,39	2,39	411	2,9			
	3	755	3,82	3,02	657	6,9	3,31	2,81	569	5,3	2,48	2,48	427	3,2	2,05	2,05	353	2,2			
	1	575	3,06	2,38	526	4,7	2,66	2,22	457	3,6	1,95	1,95	336	2,1	1,62	1,62	278	1,5			

Correction factors for different R.H.

R.H.	WT:	7/12°C	8/13°C	10/15°C	12/17°C
48%	Pc	0,95	0,94	1,00	1,00
	Ps	1,00	1,00	1,00	1,00
46%	Pc	0,90	0,88	1,00	1,00
	Ps	1,00	1,00	1,00	1,00

LEGEND

- WT = Water temperature
- Pc = Cooling total emission
- Ps = Cooling sensible emission
- Qw = Water flow
- Dp(c) = Water pressure drop
- Vdc = Inverter Power
- Qv = Air flow

Heating emission of 3 row coil

Entering air temperature: 20°C

MODEL ECM	Vdc	WT: 70/60 °C			WT: 60/50 °C			WT: 50/40 °C			WT: 50/45 °C			WT: 45/40 °C			
		Qv m³/h	Ph kW	Qw l/h	Dp(c) kPa	Ph kW	Qw l/h	Dp(c) kPa	Ph kW	Qw l/h	Dp(c) kPa	Ph kW	Qw l/h	Dp(c) kPa	Ph kW	Qw l/h	Dp(c) kPa
CRC 23	10	330	3,64	313	6,7	2,78	239	4,3	1,92	165	2,3	2,22	383	10	1,80	309	7,0
	7,5	270	3,09	265	5,0	2,36	203	3,2	1,63	140	1,7	1,89	324	7,5	1,52	262	5,2
	5	220	2,61	224	3,7	1,99	171	2,4	1,38	119	1,3	1,59	274	5,6	1,29	222	3,9
	3	170	2,10	181	2,5	1,61	138	1,6	1,12	96	0,9	1,28	221	3,8	1,04	179	2,7
	1	120	1,55	133	1,5	1,19	102	1,0	0,83	71	0,5	0,95	163	2,2	0,77	132	1,6
CRC 43	10	515	6,33	544	25,2	4,86	418	16,3	3,39	291	8,9	3,87	665	37,9	3,14	540	26,7
	7,5	430	5,43	467	19,2	4,17	359	12,5	2,91	250	6,8	3,32	571	28,9	2,69	463	20,4
	5	350	4,55	391	14,1	3,50	301	9,1	2,44	210	5,0	2,78	478	21,2	2,26	388	14,9
	3	280	3,70	318	9,8	2,85	245	6,4	1,99	171	3,5	2,26	389	14,7	1,84	316	10,4
	1	210	2,85	245	6,2	2,20	189	4,0	1,54	133	2,2	1,74	300	9,3	1,42	244	6,6
CRC 63	10	735	8,37	719	16	6,41	551	10,3	4,45	383	5,6	5,11	879	24,1	4,14	712	17
	7,5	610	7,17	616	12,2	5,50	473	7,9	3,82	329	4,3	4,38	753	18,4	3,55	610	12,9
	5	495	6,04	520	9,0	4,64	399	5,9	3,23	278	3,2	3,69	635	13,6	3,00	515	9,6
	3	395	4,97	427	6,4	3,82	328	4,2	2,66	229	2,3	3,03	522	9,6	2,46	424	6,8
	1	305	3,95	339	4,3	3,04	261	2,8	2,12	182	1,5	2,41	415	6,4	1,96	337	4,5
CRC 73	10	890	10,25	882	26,7	7,87	677	17,3	5,49	472	9,5	6,26	1077	40,1	5,08	874	28,3
	7,5	755	8,94	769	21	6,87	591	13,6	4,79	412	7,5	5,46	939	31,5	4,43	762	22,2
	5	610	7,50	645	15,4	5,77	496	10	4,03	347	5,5	4,58	788	23,2	3,72	640	16,4
	3	500	6,30	542	11,3	4,85	417	7,4	3,93	338	4,1	3,85	662	17	3,13	538	12,1
	1	400	5,16	444	8,0	3,98	342	5,2	2,79	240	2,9	3,15	542	12	2,56	441	8,5
CRC 93	10	1395	14,95	1285	22,9	11,42	982	14,7	7,90	679	8,0	9,13	1570	34,5	7,38	1270	24,2
	7,5	1175	13,06	1123	18,1	9,99	859	11,6	6,92	595	6,3	7,98	1372	27,2	6,46	1111	19,1
	5	945	10,94	941	13,2	8,38	720	8,5	5,81	500	4,6	6,68	1149	19,9	5,41	931	14
	3	785	9,40	809	10,1	7,21	620	6,5	5,00	430	3,6	5,74	988	15,3	4,66	801	10,7
	1	605	7,55	649	6,9	5,79	498	4,5	4,03	347	2,4	4,61	793	10,4	3,74	643	7,3

LEGEND

- WT = Water temperature
- Ph = Emission
- Qw = Water flow
- Dp(c) = Water pressure drop
- Vdc = Inverter Power
- Qv = Air flow

Heating emission of 4 row coil

Entering air temperature: 20°C

MODEL ECM	Vdc	WT: 70/60 °C				WT: 60/50 °C			WT: 50/40 °C			WT: 50/45 °C			WT: 45/40 °C		
		Qv	Ph	Qw	Dp(c)	Ph	Qw	Dp(c)	Ph	Qw	Dp(c)	Ph	Qw	Dp(c)	Ph	Qw	Dp(c)
		m³/h	kW	l/h	kPa	kW	l/h	kPa	kW	l/h	kPa	kW	l/h	kPa	kW	l/h	kPa
CRC 24	10	325	4,01	344	12,9	3,07	264	8,3	2,14	184	4,5	2,45	421	19,4	1,98	341	13,6
	7,5	260	3,33	286	9,3	2,56	220	6,0	1,78	153	3,3	2,03	350	14	1,65	284	9,9
	5	210	2,75	237	6,7	2,12	182	4,3	1,48	127	2,4	1,68	289	10	1,37	235	7,1
	3	160	2,18	187	4,4	1,68	144	2,9	1,17	101	1,6	1,33	229	6,6	1,08	186	4,7
	1	115	1,57	135	2,5	1,21	104	1,6	0,85	73	0,9	0,96	165	3,7	0,78	134	2,6
CRC 44	10	505	6,60	568	12,9	5,07	436	8,4	3,54	304	4,6	4,04	694	19,5	3,28	563	13,7
	7,5	415	5,57	479	9,6	4,29	369	6,2	3,00	258	3,4	3,41	586	14,5	2,77	476	10,2
	5	340	4,59	394	6,8	3,53	304	4,4	2,48	213	2,5	2,81	484	10,3	2,29	394	7,3
	3	265	3,67	316	4,6	2,83	243	3,0	1,99	171	1,7	2,24	386	6,9	1,83	314	4,9
	1	200	2,83	244	2,9	2,19	188	1,9	1,54	132	1,1	1,73	298	4,4	1,41	243	3,1
CRC 64	10	720	9,43	811	27,4	7,26	624	17,8	5,08	437	9,8	5,76	991	41,2	4,68	805	29,1
	7,5	590	7,90	679	20,1	6,09	523	13,1	4,27	367	7,2	4,83	830	30,2	3,93	675	21,4
	5	475	6,48	557	14,2	5,00	430	9,2	3,51	302	5,1	3,96	681	21,3	3,23	555	15,1
	3	375	5,21	448	9,6	4,02	346	6,3	2,83	243	3,5	3,19	548	14,5	2,59	446	10,3
	1	290	4,05	348	6,2	3,13	269	4,1	2,21	190	2,3	2,48	426	9,3	2,02	347	6,6
CRC 74	10	875	10,93	940	20,7	8,41	723	13,5	5,88	505	7,4	6,68	1149	31,2	5,43	933	22
	7,5	735	9,39	808	15,9	7,23	622	10,3	5,06	435	5,7	5,74	987	23,9	4,66	802	16,9
	5	585	7,73	664	11,3	5,95	512	7,3	4,17	359	4,1	4,72	812	16,9	3,84	660	12
	3	475	6,38	549	8,0	4,92	423	5,2	3,45	297	2,9	3,90	671	12,1	3,17	546	8,6
	1	380	5,16	444	5,5	3,98	342	3,6	2,80	241	2,0	3,15	542	8,3	2,57	442	5,9
CRC 94	10	1365	16,03	1379	19,8	12,27	1055	12,8	8,50	731	6,9	9,79	1685	29,8	7,93	1364	20,9
	7,5	1145	13,82	1188	15,2	10,58	910	9,8	7,35	632	5,3	8,44	1452	22,9	6,84	1176	16,1
	5	910	11,37	978	10,8	8,72	750	7,0	6,06	521	3,8	6,94	1194	16,3	5,63	969	11,4
	3	755	9,69	834	8,2	7,44	640	5,3	5,18	446	2,9	5,92	1019	12,3	4,81	826	8,7
	1	575	7,58	652	5,3	5,82	501	3,4	4,07	350	1,9	4,63	796	8,0	3,76	647	5,6

LEGEND

- WT = Water temperature
- Ph = Emission
- Qw = Water flow
- Dp(c) = Water pressure drop
- Vdc = Inverter Power
- Qv = Air flow

Heating emission of 1 row additional coil

Entering air temperature: 20°C

MODEL ECM	Vdc	WT: 80/70 °C				WT: 75/65 °C				WT: 70/60 °C				WT: 65/55 °C				WT: 60/50 °C				WT: 55/45 °C			
		Qv	Ph	Qw	Dp(c)	Ph	Qw	Dp(c)	Ph	Qw	Dp(c)	Ph	Qw	Dp(c)	Ph	Qw	Dp(c)	Ph	Qw	Dp(c)	Ph	Qw	Dp(c)		
		m³/h	kW	l/h	kPa	kW	l/h	kPa	kW	l/h	kPa	kW	l/h	kPa	kW	l/h	kPa	kW	l/h	kPa	kW	l/h	kPa		
CRC 2	10	330	2,04	176	6,3	1,84	158	5,3	1,63	140	4,3	1,43	123	3,5	1,22	105	2,7	1,018	88	2,0					
	7,5	270	1,78	153	4,9	1,60	138	4,1	1,42	122	3,4	1,24	107	2,7	1,07	92	2,1	0,888	76	1,6					
	5	220	1,54	132	3,8	1,38	119	3,2	1,23	106	2,6	1,08	93	2,1	0,92	79	1,6	0,77	66	1,2					
	3	170	1,29	111	2,8	1,16	100	2,4	1,04	89	1,9	0,91	78	1,6	0,78	67	1,2	0,65	56	0,9					
	1	120	1,02	87	1,8	0,92	79	1,5	0,81	70	1,3	0,71	61	1,0	0,61	53	0,8	0,512	44	0,6					
CRC 4	10	515	3,41	293	19,4	3,08	264	16,4	2,74	236	13,6	2,41	207	11	2,07	178	8,6	1,74	150	6,4					
	7,5	430	3,01	259	15,6	2,72	234	13,2	2,42	208	10,9	2,13	183	8,8	1,83	158	6,9	1,54	132	5,2					
	5	350	2,62	225	12,2	2,36	203	10,3	2,11	181	8,5	1,85	159	6,9	1,60	137	5,4	1,34	115	4,0					
	3	280	2,22	191	9,1	2,01	172	7,7	1,79	154	6,4	1,57	135	5,2	1,36	117	4,1	1,139	98	3,0					
	1	210	1,82	157	6,4	1,64	141	5,4	1,47	126	4,5	1,29	111	3,6	1,11	96	2,9	0,935	80	2,1					
CRC 6	10	735	4,61	396	6,4	4,14	356	5,4	3,68	317	4,5	3,22	277	3,6	2,76	238	2,8	2,303	198	2,0					
	7,5	610	4,05	348	5,1	3,64	313	4,3	3,24	278	3,6	2,83	244	2,9	2,43	209	2,2	2,029	174	1,6					
	5	495	3,50	301	4,0	3,15	271	3,3	2,80	241	2,8	2,45	211	2,2	2,11	181	1,7	1,76	151	1,3					
	3	395	3,00	258	3,0	2,70	232	2,5	2,40	206	2,1	2,10	181	1,7	1,81	155	1,3	1,509	130	1,0					
	1	305	2,50	215	2,2	2,25	194	1,9	2,00	172	1,5	1,76	151	1,2	1,51	130	1,0	1,263	109	0,7					
CRC 7	10	890	5,77	496	11,2	5,20	447	9,5	4,63	398	7,8	4,06	349	6,3	3,50	301	4,9	2,929	252	3,7					
	7,5	755	5,15	443	9,2	4,64	399	7,8	4,13	355	6,4	3,63	312	5,2	3,12	268	4,0	2,616	225	3,0					
	5	610	4,43	381	7,1	4,00	344	6,0	3,56	306	4,9	3,13	269	4,0	2,69	231	3,1	2,258	194	2,3					
	3	500	3,86	332	5,5	3,48	299	4,7	3,10	267	3,9	2,72	234	3,1	2,35	202	2,4	1,969	169	1,8					
	1	400	3,30	284	4,2	2,97	256	3,5	2,65	228	2,9	2,33	200	2,4	2,01	173	1,9	1,685	145	1,4					
CRC 9	10	1395	7,46	641	17,6	6,72	578	14,9	5,98	514	12,3	5,24	451	9,9	4,51	388	7,7	3,772	324	5,7					
	7,5	1175	6,67	574	14,5	6,01	517	12,2	5,35	460	10,1	4,69	404	8,2	4,04	347	6,4	3,379	291	4,7					
	5	945	5,75	495	11,2	5,18	446	9,4	4,62	397	7,8	4,05	348	6,3	3,48	300	4,9	2,919	251	3,7					
	3	785	5,08	437	9,0	4,58	394	7,6	4,08	351	6,3	3,58	308	5,1	3,08	265	3,9	2,582	222	2,9					
	1	605	4,23	364	6,5	3,82	328	5,5	3,40	292	4,6	2,99	257	3,7	2,57	221	2,9	2,158	186	2,1					

LEGEND

- WT = Water temperature
- Ph = Emission
- Qw = Water flow
- Dp(c) = Water pressure drop
- Vdc = Inverter Power
- Qv = Air flow

Heating emission of 2 row additional coil

Entering air temperature: 20°C

MODEL ECM	Vdc	WT: 65/55 °C			WT: 60/50 °C			WT: 55/45 °C			WT: 50/40 °C			WT: 45/40 °C			WT: 45/35 °C			
		Qv	Ph	Qw	Dp(c)	Ph	Qw	Dp(c)	Ph	Qw	Dp(c)	Ph	Qw	Dp(c)	Ph	Qw	Dp(c)	Ph	Qw	Dp(c)
		m³/h	kW	l/h	kPa	kW	l/h	kPa	kW	l/h	kPa	kW	l/h	kPa	kW	l/h	kPa	kW	l/h	kPa
CRC 2	10	330	2,48	214	16,7	2,15	184	13,1	1,81	155	9,9	1,47	126	7,0	1,39	239	21,6	1,13	97	4,5
	7,5	270	2,13	183	12,7	1,84	158	10	1,55	133	7,5	1,26	109	5,3	1,19	205	16,5	0,97	84	3,4
	5	220	1,81	155	9,6	1,56	134	7,5	1,32	113	5,7	1,07	92	4,0	1,01	174	12,4	0,83	71	2,6
	3	170	1,49	128	6,8	1,29	111	5,3	1,10	94	4,1	0,89	77	2,9	0,84	144	8,9	0,69	59	1,9
	1	120	1,13	97	4,2	0,98	84	3,3	0,83	71	2,5	0,68	58	1,8	0,63	109	5,4	0,52	45	1,2
CRC 4	10	515	3,90	335	7,6	3,36	289	5,9	2,82	243	4,4	2,29	197	3,1	2,18	375	9,8	1,76	151	2,0
	7,5	430	3,40	292	5,9	2,93	252	4,7	2,47	212	3,5	2,00	172	2,5	1,90	327	7,7	1,54	132	1,6
	5	350	2,90	249	4,5	2,50	215	3,5	2,11	181	2,6	1,71	147	1,9	1,62	279	5,8	1,32	113	1,2
	3	280	2,43	209	3,3	2,10	181	2,6	1,77	152	1,9	1,44	124	1,4	1,36	234	4,3	1,11	95	0,9
	1	210	1,94	166	2,2	1,67	144	1,7	1,41	121	1,3	1,15	99	0,9	1,08	186	2,8	0,89	76	0,6
CRC 6	10	735	5,63	484	17,8	4,87	419	14	4,11	353	10,5	3,35	288	7,5	3,15	542	23	2,59	223	4,9
	7,5	610	4,88	419	13,8	4,22	363	10,9	3,56	306	8,2	2,91	250	5,8	2,73	470	17,9	2,25	194	3,8
	5	495	4,14	356	10,3	3,58	308	8,1	3,03	260	6,2	2,47	213	4,4	2,32	398	13,4	1,92	165	2,9
	3	395	3,46	297	7,5	3,00	258	5,9	2,53	218	4,5	2,09	180	3,3	1,96	336	9,9	1,62	139	2,1
	1	305	2,83	243	5,3	2,45	211	4,2	2,08	178	3,2	1,70	146	2,3	1,58	272	6,9	1,32	113	1,5
CRC 7	10	890	7,01	603	31,1	6,07	522	24,5	5,14	442	18,6	4,20	361	13,3	3,93	675	40,2	3,27	281	8,7
	7,5	755	6,17	530	24,8	5,34	460	19,6	4,52	389	14,8	3,70	318	10,6	3,45	594	32,1	2,88	248	6,9
	5	610	5,20	447	18,4	4,51	388	14,5	3,82	328	11	3,13	269	7,9	2,91	501	23,8	2,44	209	5,2
	3	500	4,47	384	14,1	3,88	333	11,1	3,28	282	8,4	2,69	232	6,1	2,50	431	18,2	2,10	180	4,0
	1	400	3,72	320	10,2	3,23	277	8,1	2,74	235	6,1	2,24	193	4,4	2,08	358	13,2	1,75	151	2,9
CRC 9	10	1395	9,60	825	54	8,31	714	42,6	7,02	604	32,2	5,74	493	22,9	-	-	-	4,45	383	15
	7,5	1175	8,49	730	43,5	7,35	632	34,3	6,22	535	26	5,08	437	18,5	-	-	-	3,94	339	12,1
	5	945	7,22	621	32,7	6,25	538	25,8	5,29	455	19,5	4,33	372	14	-	-	-	3,36	289	9,1
	3	785	6,28	540	25,6	5,45	468	20,2	4,61	396	15,3	3,77	324	11	-	-	-	2,93	252	7,2
	1	605	5,12	440	17,8	4,44	381	14,1	3,76	323	10,7	3,08	265	7,7	-	-	-	2,40	206	5,0

LEGEND

- WT = Water temperature
- Ph = Emission
- Qw = Water flow
- Dp(c) = Water pressure drop
- Vdc = Inverter Power
- Qv = Air flow

Air flow and correction factors for emission with different available pressures

MODEL ECM	Vdc	Qv (m³/h)									K1									K2									
		Ap (Pa)									Ap (Pa)									Ap (Pa)									
		0	5	10	15	20	25	30	35	40	0	5	10	15	20	25	30	35	40	0	5	10	15	20	25	30	35	40	
CRC 2	10	330	312	288	257	223	171	88	-	-	1,00	0,95	0,89	0,82	0,73	0,60	0,32	-	-	-	0,95	0,88	0,80	0,72	0,58	0,29	-	-	
	8,5	307	276	251	213	162	92	29	-	-	1,00	0,91	0,85	0,75	0,61	0,36	0,06	-	-	-	1,00	0,90	0,83	0,73	0,59	0,34	0,03	-	-
	7,5	270	252	219	178	103	-	-	-	-	1,00	0,94	0,84	0,72	0,46	-	-	-	-	-	1,00	0,94	0,83	0,70	0,44	-	-	-	-
	6,5	248	227	187	130	56	-	-	-	-	1,00	0,93	0,80	0,60	0,26	-	-	-	-	-	1,00	0,92	0,78	0,58	0,24	-	-	-	-
	5	220	187	126	55	-	-	-	-	-	1,00	0,88	0,65	0,30	-	-	-	-	-	-	1,00	0,86	0,63	0,27	-	-	-	-	-
	3	170	122	45	-	-	-	-	-	-	1,00	0,77	0,32	-	-	-	-	-	-	-	1,00	0,75	0,29	-	-	-	-	-	-
	2	144	82	-	-	-	-	-	-	-	1,00	0,65	-	-	-	-	-	-	-	-	1,00	0,63	-	-	-	-	-	-	-
	1	120	68	-	-	-	-	-	-	-	1,00	0,64	-	-	-	-	-	-	-	-	1,00	0,62	-	-	-	-	-	-	-
CRC 4	10	515	499	477	448	401	332	247	100	-	1,00	0,97	0,94	0,89	0,82	0,71	0,56	0,22	-	-	0,97	0,93	0,88	0,80	0,69	0,54	0,19	-	
	8,5	459	444	419	377	323	229	54	-	-	1,00	0,97	0,93	0,85	0,76	0,58	0,10	-	-	-	1,00	0,97	0,92	0,84	0,74	0,56	0,07	-	-
	7,5	430	396	363	320	240	89	-	-	-	1,00	0,93	0,87	0,79	0,63	0,24	-	-	-	-	1,00	0,92	0,86	0,77	0,61	0,21	-	-	-
	6,5	394	374	333	272	135	-	-	-	-	1,00	0,95	0,87	0,74	0,41	-	-	-	-	-	1,00	0,95	0,86	0,73	0,39	-	-	-	-
	5	350	308	255	107	-	-	-	-	-	1,00	0,90	0,78	0,37	-	-	-	-	-	-	1,00	0,89	0,76	0,35	-	-	-	-	-
	3	280	227	99	-	-	-	-	-	-	1,00	0,84	0,43	-	-	-	-	-	-	-	1,00	0,83	0,41	-	-	-	-	-	-
	2	233	170	-	-	-	-	-	-	-	1,00	0,78	-	-	-	-	-	-	-	-	1,00	0,76	-	-	-	-	-	-	-
	1	210	126	-	-	-	-	-	-	-	1,00	0,67	-	-	-	-	-	-	-	-	1,00	0,65	-	-	-	-	-	-	-
CRC 6	10	735	696	673	622	558	431	286	168	-	1,00	0,95	0,93	0,87	0,80	0,66	0,47	0,27	-	-	0,95	0,92	0,86	0,78	0,64	0,45	0,24	-	
	8,5	650	628	583	525	421	269	110	-	-	1,00	0,97	0,91	0,84	0,71	0,49	0,18	-	-	-	1,00	0,97	0,90	0,82	0,69	0,47	0,15	-	-
	7,5	610	564	528	437	284	129	-	-	-	1,00	0,94	0,89	0,77	0,55	0,25	-	-	-	-	1,00	0,93	0,87	0,75	0,53	0,22	-	-	-
	6,5	558	510	457	340	189	-	-	-	-	1,00	0,93	0,85	0,68	0,41	-	-	-	-	-	1,00	0,92	0,83	0,66	0,39	-	-	-	-
	5	495	432	352	154	-	-	-	-	-	1,00	0,89	0,76	0,38	-	-	-	-	-	-	1,00	0,88	0,74	0,36	-	-	-	-	-
	3	395	319	151	82	-	-	-	-	-	1,00	0,84	0,46	0,24	-	-	-	-	-	-	1,00	0,82	0,44	0,21	-	-	-	-	-
	2	351	221	-	-	-	-	-	-	-	1,00	0,70	-	-	-	-	-	-	-	-	1,00	0,68	-	-	-	-	-	-	-
	1	305	177	-	-	-	-	-	-	-	1,00	0,65	-	-	-	-	-	-	-	-	1,00	0,63	-	-	-	-	-	-	-
CRC 7	10	890	846	815	756	699	590	486	341	191	1,00	0,96	0,93	0,87	0,82	0,72	0,62	0,46	0,25	-	0,95	0,92	0,86	0,81	0,70	0,60	0,44	0,22	
	8,5	805	756	703	652	560	437	279	114	-	1,00	0,95	0,89	0,84	0,75	0,62	0,42	0,14	-	-	1,00	0,94	0,88	0,83	0,73	0,60	0,40	0,11	-
	7,5	755	696	637	558	459	300	140	-	-	1,00	0,93	0,87	0,79	0,68	0,48	0,21	-	-	-	1,00	0,93	0,86	0,77	0,66	0,46	0,18	-	-
	6,5	703	637	560	449	336	175	-	-	-	1,00	0,92	0,83	0,70	0,56	0,30	-	-	-	-	1,00	0,91	0,82	0,68	0,54	0,27	-	-	-
	5	610	532	443	313	133	-	-	-	-	1,00	0,89	0,78	0,59	0,26	-	-	-	-	-	1,00	0,88	0,76	0,57	0,23	-	-	-	-
	3	500	398	255	83	-	-	-	-	-	1,00	0,83	0,59	0,18	-	-	-	-	-	-	1,00	0,81	0,57	0,15	-	-	-	-	-
	2	452	348	178	-	-	-	-	-	-	1,00	0,81	0,47	-	-	-	-	-	-	-	1,00	0,79	0,45	-	-	-	-	-	-
	1	400	279	-	-	-	-	-	-	-	1,00	0,75	-	-	-	-	-	-	-	-	1,00	0,73	-	-	-	-	-	-	-
CRC 9	10	1395	1310	1225	1180	1125	1060	1000	930	860	1,00	0,95	0,90	0,87	0,84	0,80	0,77	0,73	0,68	-	0,94	0,89	0,86	0,82	0,78	0,75	0,71	0,66	
	8,5	1265	1175	1080	1020	960	880	800	720	640	1,00	0,94	0,88	0,84	0,80	0,75	0,70	0,64	0,59	-	1,00	0,93	0,86	0,82	0,78	0,73	0,68	0,62	0,57
	7,5	1175	1075	970	910	840	750	650	545	450	1,00	0,93	0,85	0,81	0,77	0,70	0,63	0,54	0,46	-	1,00	0,92	0,84	0,80	0,75	0,68	0,61	0,52	0,44
	6,5	1085	980	865	790	700	605	500	350	200	1,00	0,92	0,83	0,78	0,71	0,63	0,54	0,39	0,21	-	1,00	0,91	0,82	0,76	0,69	0,61	0,52	0,37	0,18
	5	945	835	680	580	460	315	160	-	-	1,00	0,90	0,77	0,68	0,57	0,40	0,18	-	-	-	1,00	0,89	0,75	0,66	0,55	0,38	0,15	-	-
	3	785	620	400	230	50	-	-	-	-	1,00	0,83	0,59	0,35	-	-	-	-	-	-	1,00	0,81	0,57	0,33	-	-	-	-	-
	2	700	500	200	-	-	-	-	-	-	1,00	0,77	0,34	-	-	-	-	-	-	-	1,00	0,75	0,32	-	-	-	-	-	-
	1	605	390	-	-	-	-	-	-	-	1,00	0,71	-	-	-	-	-	-	-	-	1,00	0,69	-	-	-	-	-	-	-

LEGEND

- Qv = Air flow
- K1 = Correction factors for Total cooling emission
- K2 = Correction factors for Sensible cooling emission and Heating emission
- Ap = Available pressure
- Vdc = Inverter Power

Water pressure drop

3 row coil

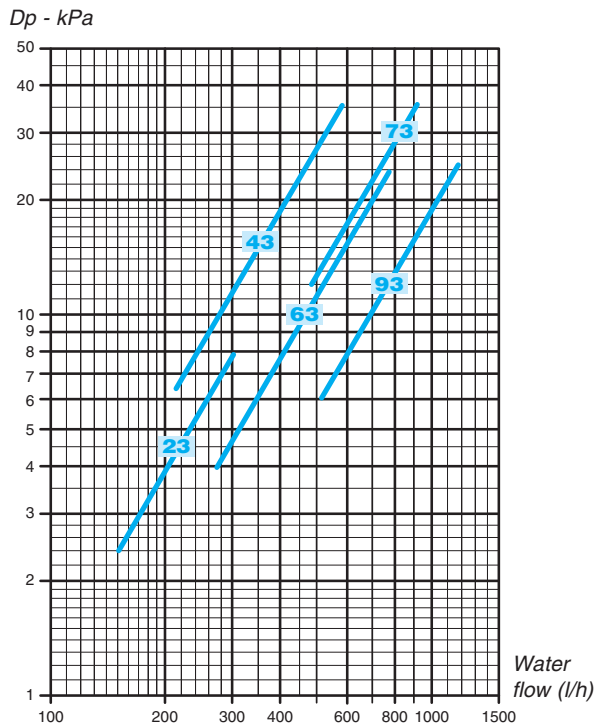

4 row coil

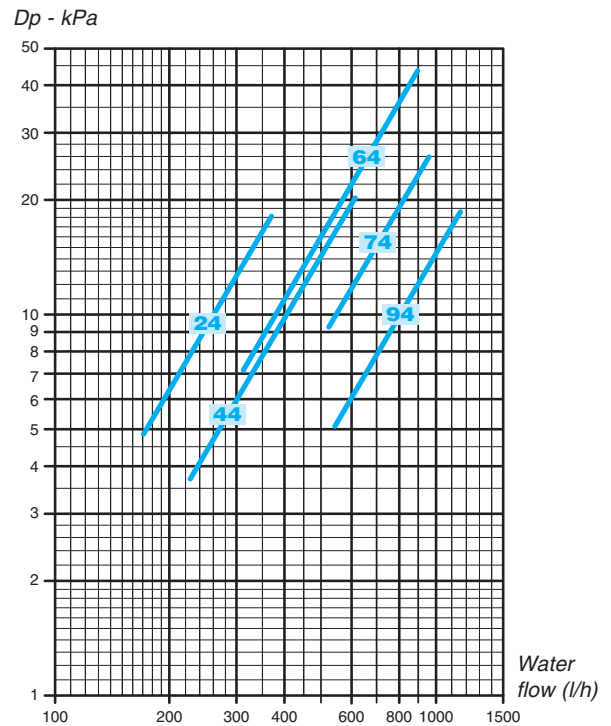

The water pressure drop figures refer to a mean water temperature of **10°C**; for different temperatures, multiply the pressure drop figures by the correction factors **K**.

°C	20	30	40	50	60	70	80
K	0,94	0,90	0,86	0,82	0,78	0,74	0,70

1 row additional coil

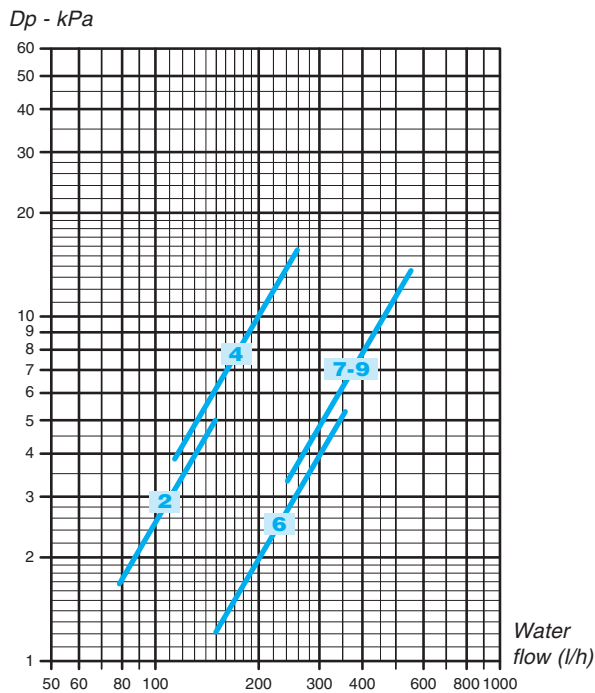

2 row additional coil

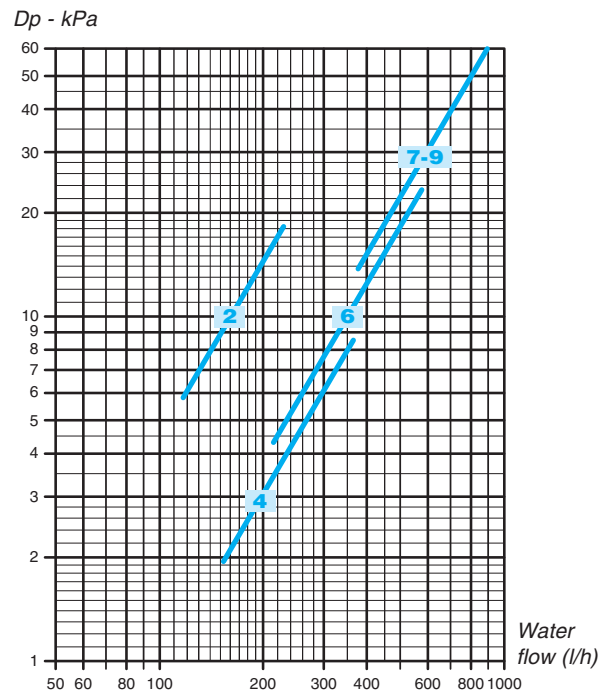

The water pressure drop figures refer to a mean water temperature of **65°C**; for different temperatures, multiply the pressure drop figures by the correction factors **K**.

°C	40	50	60	70	80
K	1,14	1,08	1,02	0,96	0,90

Construction

Outer casing

Made from strong synthetic lateral corners and from galvanized and prepainted frontal steel sheet. The plastic top grid has fixed louvres and is reversible in order to distribute the air in two different directions.

Standard colours:

- Lateral corners and top grid: **Pantone Cool Grey 1C (light grey)**
- Frontal sheet: **RAL 9003 (white)**
- Other colours on request.

Inner casing

Made from 1 mm galvanized steel insulated with polyolefin (PO) foam (class M1).

Filter

Polypropylene cellular fabric regenerating filter. The filter frame of galvanized steel is inserted into special plastic sliding guides fastened to the internal structure for easy insertion and removal of the filter. Filter presence is highlighted by a plastic front cover featuring the same colour as the top grid.



Fan assembly

The tangential fan assembly is composed of two fan shrouds: an external one in ABS and an internal one of holed, shaped steel. The fan has an external diameter of 120mm and is the length of the coil. The fins are concave and are positioned in a spiral shape along the whole length of the fan.

Electronic motor

Three phase permanent magnet brushless electronic motor that is controlled with reconstructed current according to a BLAC sinusoidal wave. The inverter board that controls the motor operation is powered by 230 Volt, single-phase and, with a switching system, it generates a three-phase frequency modulated, wave form power supply. The electric power supply required for the machine is therefore single-phase with voltage of 230-240V and frequency of 50-60Hz.

Coil

It is manufactured from drawn copper tube and the aluminium fins are mechanically bonded onto the tube by an expansion process. The coil has two 1/2inch BSP internal connections and 1/8 inch BSP air vent and drain. The coil is not suitable for use in corrosive atmosphere or in environments where aluminium may be subject to corrosion.

The connections are on the left side facing the unit. On request we can deliver the unit with the connections on the right end side: this must be specified on the order as this operation can not be carried out on site during installation.

Condensate collection tray

Made from plastic (ABS UL94 HB) with an "L"-shape fitted on the inner casing; in the MO-MVB and IV-IO model the tray is insulated with polyolefin (PO) foam (class M1). The outside diameter of the condensate discharge pipe is 15mm.

Accessories and Controls

See page 62 and 75.

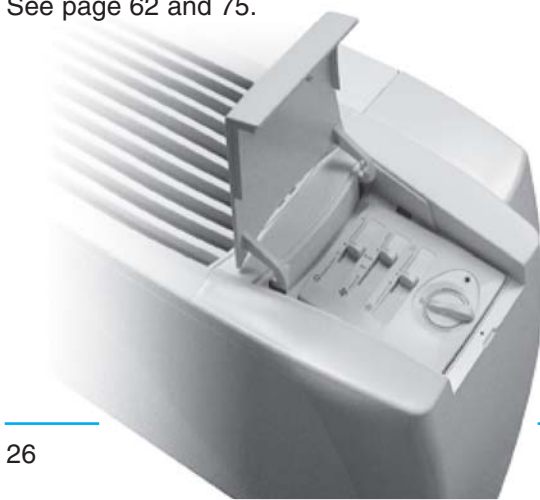

Models

MV

Vertical Casing – Wall Installation

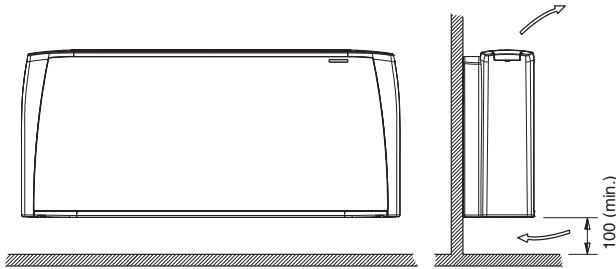

MV

Vertical Casing – Ceiling Installation

NOTE: the MV model can also be installed horizontally leaving behind a 100 mm gap for air intake.

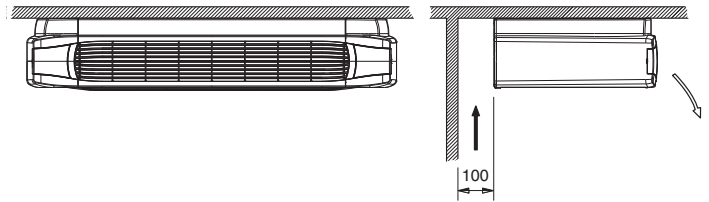

MO-MVB

Vertical Casing – Floor Installation

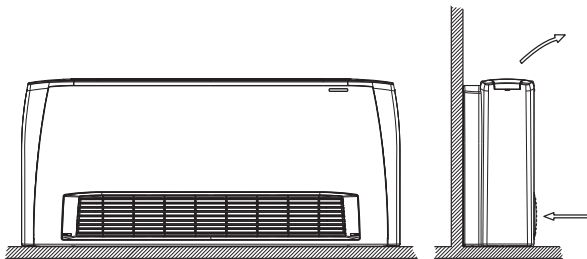

MO-MVB

Horizontal Casing

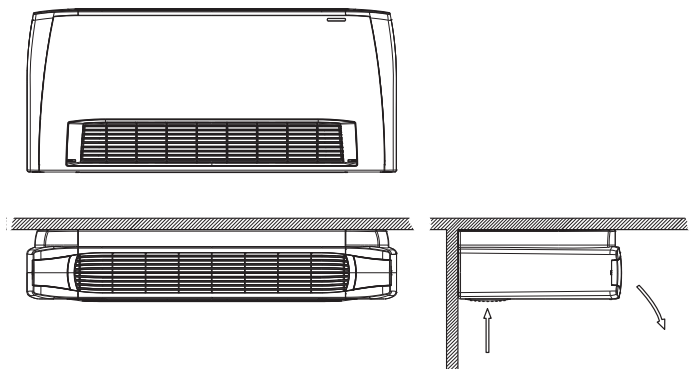

IV-IO

Vertical Concealed

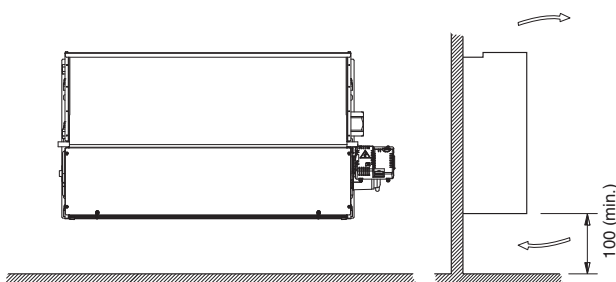

IV-IO

Horizontal Concealed

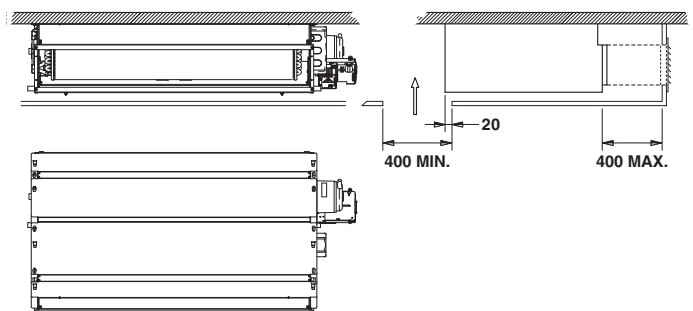

For best operation of **CRT-ECM** IV-IO units don't connect any duct on the return side and respect the minimum suggested dimension of the air intake grid.

Dimensions, Weight, Water content

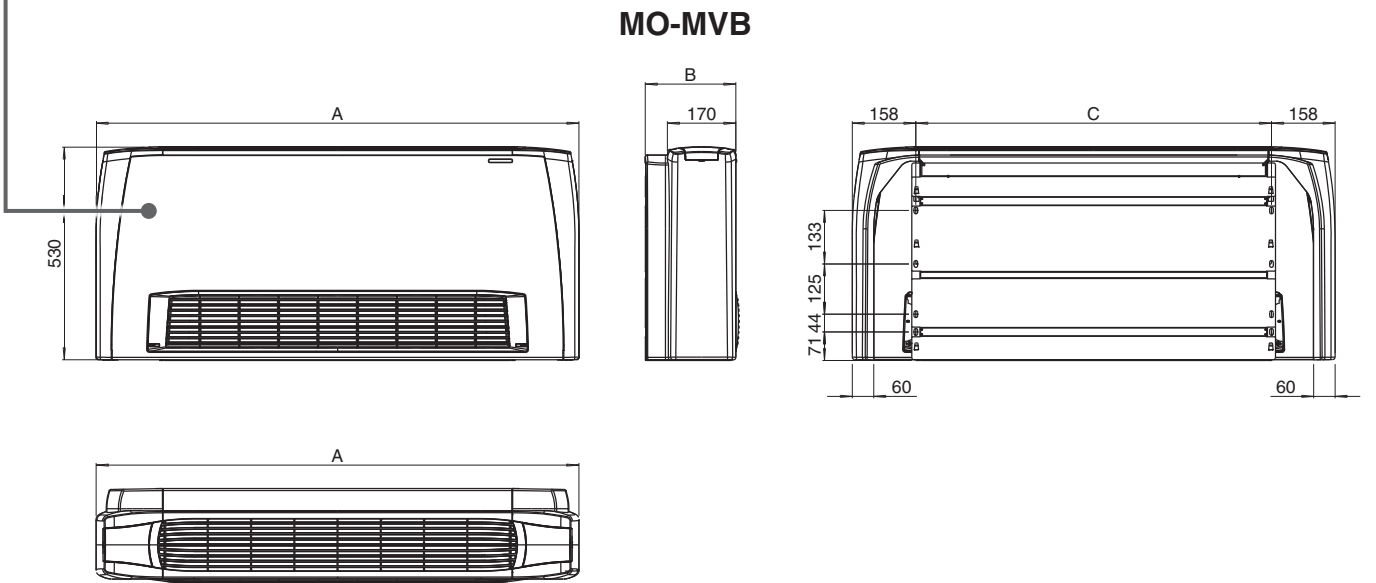
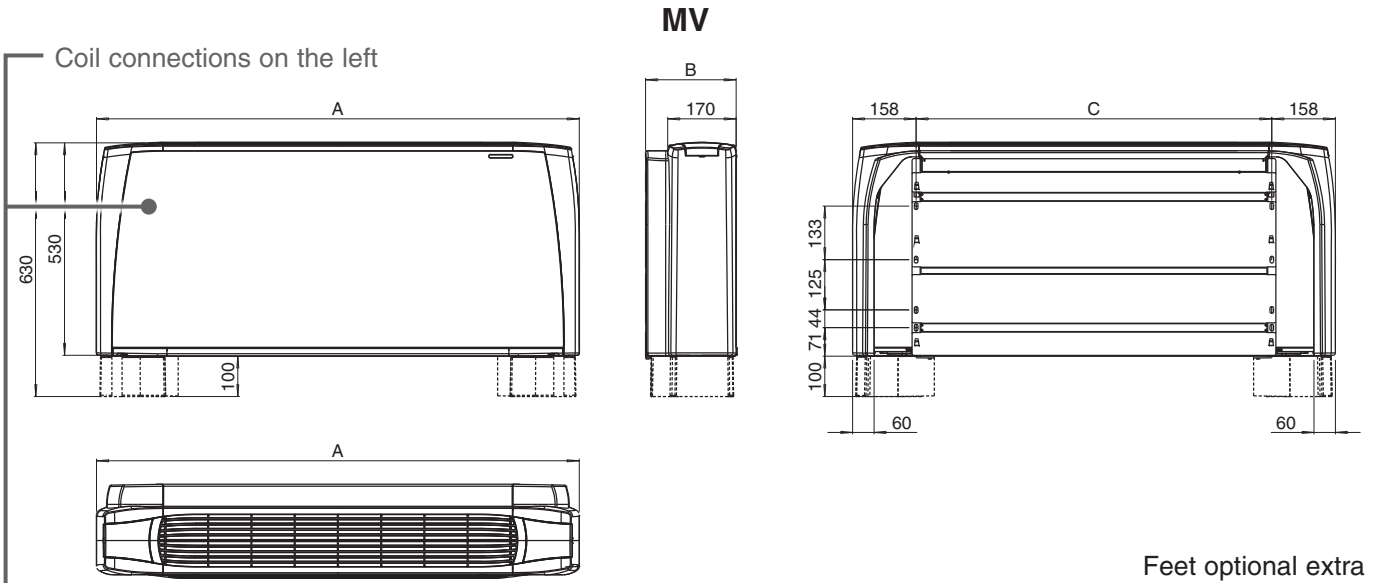

COIL CONNECTIONS

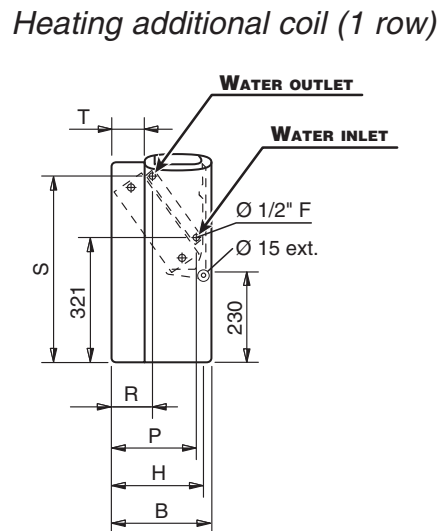
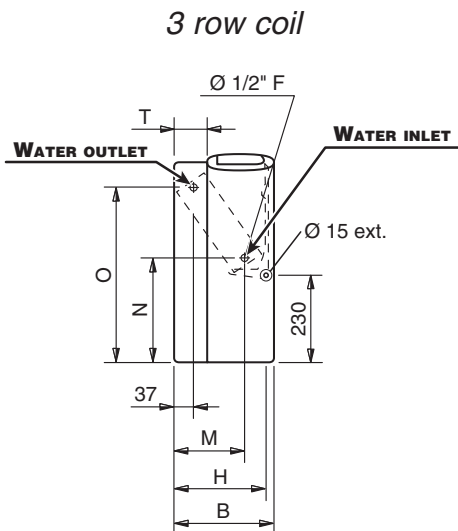

Dimensions, Weight, Water content

PACKAGING

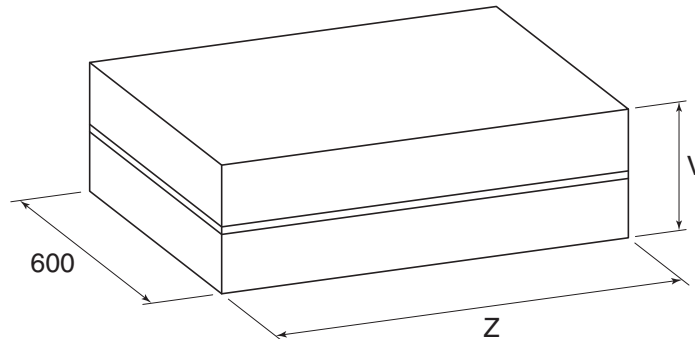

Dimensions (mm)

MODEL	1	2	3	5	7
A	670	770	985	1200	1415
B	225	225	225	225	225
C	354	454	669	884	1099
H	205	205	205	205	205
M	145	145	145	145	145
N	260	260	260	260	260
O	460	460	460	460	460
P	185	185	185	185	185
R	105	105	105	105	105
S	475	475	475	475	475
T	55	55	55	55	55
V	260	260	260	260	260
Z	720	820	1035	1250	1465

Weight (kg)

		<i>Weight with packaging</i>					<i>Weight without packaging</i>				
MODEL		1	2	3	5	7	1	2	3	5	7
Rows	3	14	16	21	24	30	13	14	18	21	26
	3+1	15	19	27	30	37	14	17	24	27	33

Water content (litres)

MODEL	1	2	3	5	7	
Rows	3	0,5	0,6	0,9	1,3	1,7
	3+1	0,2	0,2	0,3	0,4	0,5

Dimensions, Weight, Water content

IV-IO Vertical Installation

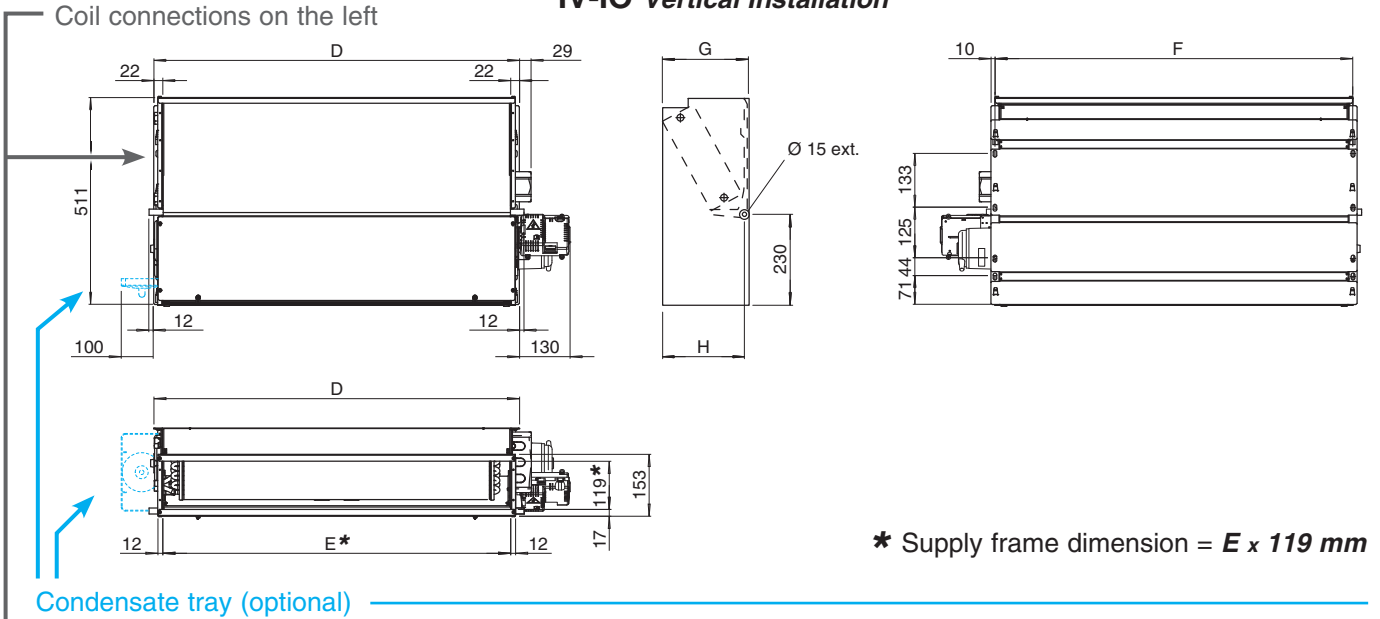

IV-IO Horizontal Installation

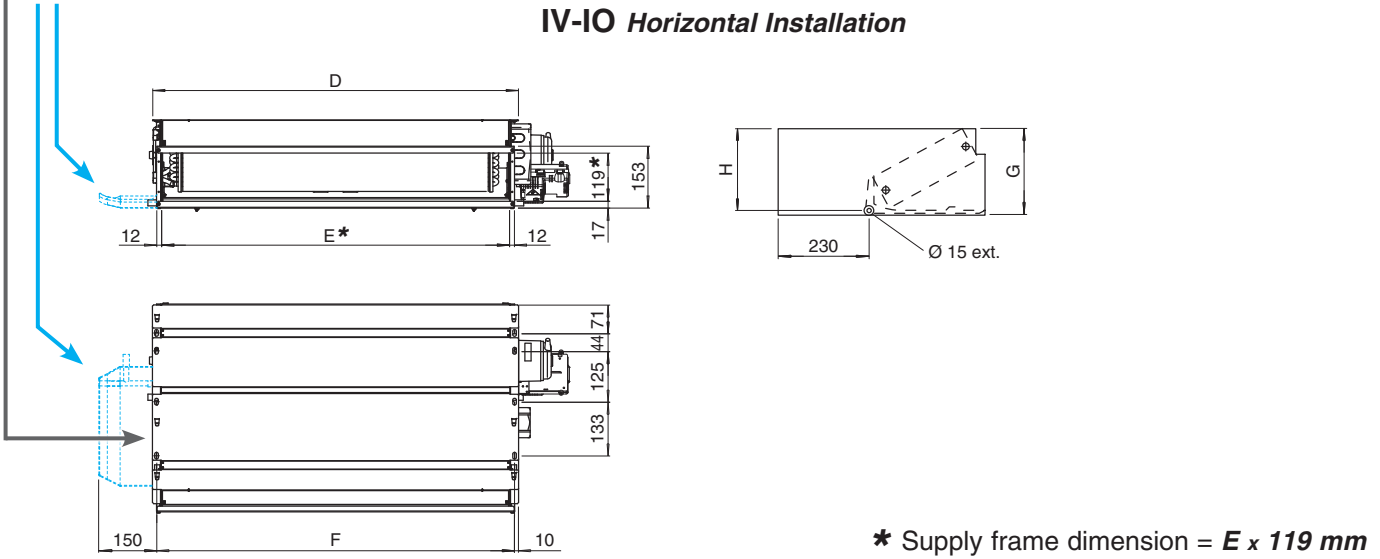

COIL CONNECTIONS

3 row coil

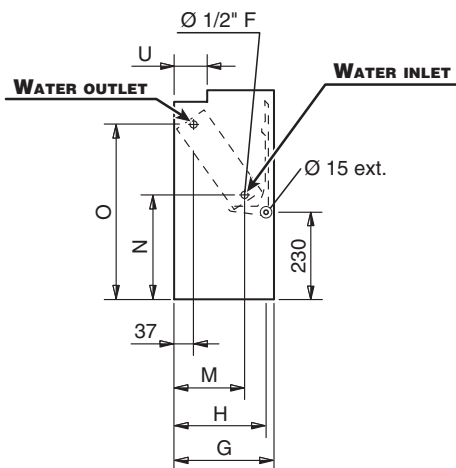

Heating additional coil (1 row)

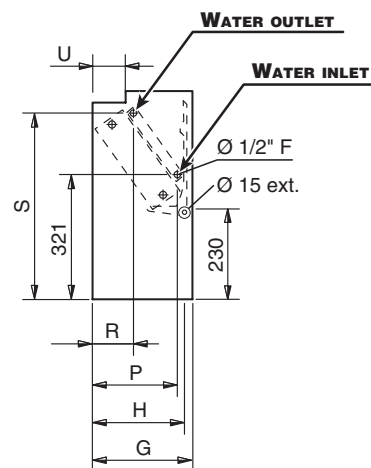

Dimensions, Weight, Water content

PACKAGING

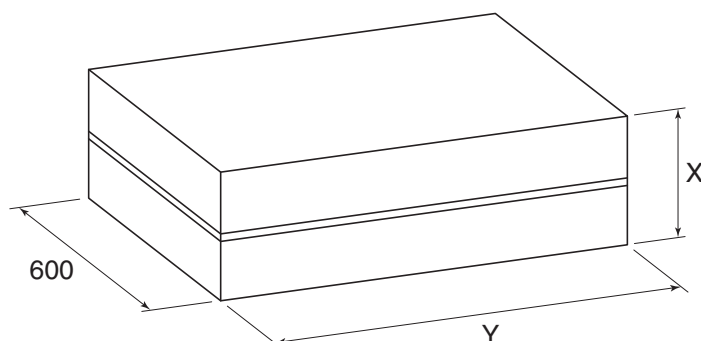

Dimensions (mm)

MODEL	1	2	3	5	7
<i>D</i>	374	474	689	904	1119
<i>E</i>	330	430	645	860	1075
<i>F</i>	354	454	669	884	1099
<i>G</i>	218	218	218	218	218
<i>H</i>	205	205	205	205	205
<i>M</i>	145	145	145	145	145
<i>N</i>	260	260	260	260	260
<i>O</i>	460	460	460	460	460
<i>P</i>	185	185	185	185	185
<i>R</i>	105	105	105	105	105
<i>S</i>	475	475	475	475	475
<i>U</i>	65	65	65	65	65
<i>X</i>	260	260	260	260	260
<i>Y</i>	720	820	820	1035	1250

Weight (kg)

		<i>Weight with packaging</i>					<i>Weight without packaging</i>				
MODEL		1	2	3	5	7	1	2	3	5	7
<i>Rows</i>	3	10	15	19	22	27	9	13	18	21	25
	3+1	11	17	25	28	34	10	16	23	26	31

Water content (litres)

MODEL	1	2	3	5	7	
<i>Rows</i>	3	0,5	0,6	0,9	1,3	1,7
	3+1	0,2	0,2	0,3	0,4	0,5

CRT-ECM UNITS WITH 3 ROW COIL

2 pipe units.

The following standard rating conditions are used:

COOLING

Entering air temperature +27°C d.b. +19°C w.b.
Water temperature +7°C E.W.T. +12°C L.W.T.

HEATING

Entering air temperature +20°C
Entering water temperature +50°C
Water flow rate as for the cooling conditions

MODEL		CRT-ECM 13			CRT-ECM 23			CRT-ECM 33		
Inverter power		1 (E)	5 (E)	10 (E)	1 (E)	5 (E)	10 (E)	1 (E)	5 (E)	10 (E)
Speed		MIN	MED	MAX	MIN	MED	MAX	MIN	MED	MAX
Air flow	m ³ /h	105	165	240	150	215	305	220	325	450
Cooling total emission (E)	kW	0,55	0,76	0,99	0,85	1,11	1,41	1,37	1,88	2,38
Cooling sensible emission (E)	kW	0,44	0,63	0,86	0,66	0,88	1,15	1,02	1,43	1,85
Heating (E)	kW	0,80	1,10	1,48	1,17	1,52	1,96	1,79	2,45	3,12
Dp Cooling (E)	kPa	0,8	1,4	2,2	2,1	3,4	5,2	7,4	12,9	19,7
Dp Heating (E)	kPa	0,7	1,1	1,8	1,7	2,7	4,2	6,2	10,4	16,0
Fan (E)	W	4,0	6,0	10,0	4,5	6,5	11,5	5,0	8,5	16,0
Sound power (E)	Lw dB(A)	29	39	48	33	43	49	33	42	49
Sound pressure (*)	Lp dB(A)	20	30	39	24	34	40	24	33	40

MODEL		CRT-ECM 53			CRT-ECM 73		
Inverter power		1 (E)	5 (E)	10 (E)	1 (E)	5 (E)	10 (E)
Speed		MIN	MED	MAX	MIN	MED	MAX
Air flow	m ³ /h	295	460	675	400	630	900
Cooling total emission (E)	kW	1,83	2,62	3,49	2,48	3,57	4,67
Cooling sensible emission (E)	kW	1,37	2,01	2,74	1,85	2,73	3,65
Heating (E)	kW	2,39	3,45	4,63	3,14	4,57	6,06
Dp Cooling (E)	kPa	4,8	9,1	15,0	9,6	18,2	29,1
Dp Heating (E)	kPa	3,9	7,4	12,1	7,7	15,0	24,0
Fan (E)	W	6,0	11,5	26,0	7,0	15,0	38,0
Sound power (E)	Lw dB(A)	35	46	53	37	48	56
Sound pressure (*)	Lp dB(A)	26	37	44	28	39	47

(E) = Eurovent certified performance.

(*) = The sound pressure levels are 9 dB(A) lower than the sound power levels and apply to the reverberant field of a 100 m³ room and a reverberation time of 0.5 sec.

EUROVENT Certification

CRT-ECM UNITS WITH 1 ROW ADDITIONAL COIL

4 pipe units.

The following standard rating conditions are used:

COOLING

Entering air temperature +27°C d.b. +19°C w.b.
Water temperature + 7°C E.W.T. +12°C L.W.T.

HEATING

Entering air temperature +20°C
Water temperature +70°C E.W.T. +60°C L.W.T.

MODEL		CRT-ECM 13+1			CRT-ECM 23+1			CRT-ECM 33+1		
Inverter power		1 (E)	5 (E)	10 (E)	1 (E)	5 (E)	10 (E)	1 (E)	5 (E)	10 (E)
Speed		MIN	MED	MAX	MIN	MED	MAX	MIN	MED	MAX
Air flow	m³/h	95	150	225	135	195	285	200	295	415
Cooling total emission (E)	kW	0,51	0,72	0,95	0,78	1,02	1,34	1,25	1,71	2,22
Cooling sensible emission (E)	kW	0,40	0,60	0,81	0,60	0,81	1,09	0,93	1,30	1,73
Heating (E)	kW	0,62	0,85	1,09	0,98	1,23	1,57	1,54	2,00	2,51
Dp Cooling (E)	kPa	0,7	1,3	2,0	1,8	2,9	4,8	6,1	10,6	16,8
Dp Heating (E)	kPa	0,7	1,1	1,8	1,7	2,5	3,9	4,9	7,8	11,6
Fan (E)	W	4,0	6,0	10,0	4,5	6,5	11,5	5,0	8,5	16,0
Sound power (E)	Lw dB(A)	29	39	48	33	43	49	33	42	49
Sound pressure (*)	Lp dB(A)	20	30	39	24	34	40	24	33	40

MODEL		CRT-ECM 53+1			CRT-ECM 73+1		
Inverter power		1 (E)	5 (E)	10 (E)	1 (E)	5 (E)	10 (E)
Speed		MIN	MED	MAX	MIN	MED	MAX
Air flow	m³/h	270	420	640	355	565	820
Cooling total emission (E)	kW	1,69	2,44	3,35	2,26	3,29	4,35
Cooling sensible emission (E)	kW	1,26	1,85	2,62	1,68	2,50	3,37
Heating (E)	kW	2,05	2,76	3,67	2,67	3,68	4,72
Dp Cooling (E)	kPa	4,2	8,0	14,0	8,2	15,8	25,7
Dp Heating (E)	kPa	1,6	2,7	4,4	3,0	5,2	8,1
Fan (E)	W	6,0	11,5	26,0	7,0	15,0	38,0
Sound power (E)	Lw dB(A)	35	46	53	37	48	56
Sound pressure (*)	Lp dB(A)	26	37	44	28	39	47

(E) = Eurovent certified performance.

(*) = The sound pressure levels are 9 dB(A) lower than the sound power levels and apply to the reverberant field of a 100 m³ room and a reverberation time of 0.5 sec.

Operation limits

Highest water inlet temperature.....+ 85 °C

Lowest water inlet temperature.....+ 5 °C

for entering water temperatures below + 5°C, contact “SABIANA” technical department

Highest working pressure..... 1000 kPa (10 bars)

Note: For MO model the maximum installation height is 2,8 m.

On heating it must be payed attention to rooms where the floor temperature is particularly low (for example less than 5°C).

In this situation the floor can cool the lower layer of air to a level that can stop the uniform diffusion of the hot air coming from the unit.

Water flow limits for 3 row coil (l/h)

MODEL	CRT-ECM 13	CRT-ECM 23	CRT-ECM 33	CRT-ECM 53	CRT-ECM 73
Lowest	100	100	100	150	150
Highest	400	500	750	1000	1500

Water flow limits for 1 row additional coil (l/h)

MODEL	CRT-ECM 13+1	CRT-ECM 23+1	CRT-ECM 33+1	CRT-ECM 53+1	CRT-ECM 73+1
Lowest	50	50	50	100	100
Highest	200	250	350	450	650

Motor electrical data (max. absorption)

MODEL	CRT-ECM 1	CRT-ECM 2	CRT-ECM 3	CRT-ECM 5	CRT-ECM 7	
230/1 50Hz	W	10,0	11,5	16,0	26,0	38,0

Cooling emission of 3 row coil

Entering air temperature: 27°C – R.H.: 50%

MODEL ECM	Vdc	WT: 7/12 °C					WT: 8/13 °C					WT: 10/15 °C					WT: 12/17 °C				
		Qv	Pc	Ps	Qw	Dp(c)	Pc	Ps	Qw	Dp(c)	Pc	Ps	Qw	Dp(c)	Pc	Ps	Qw	Dp(c)			
		m³/h	kW	kW	l/h	kPa	kW	kW	l/h	kPa	kW	kW	l/h	kPa	kW	kW	l/h	kPa			
CRT 13	10	240	1,08	0,85	186	2,5	0,95	0,80	163	2,0	0,71	0,71	122	1,2	0,60	0,60	103	0,9			
	5	165	0,82	0,62	141	1,6	0,73	0,59	126	1,3	0,52	0,51	89	0,7	0,44	0,44	76	0,5			
	1	105	0,60	0,44	103	0,9	0,53	0,41	91	0,7	0,39	0,36	67	0,4	0,31	0,31	53	0,3			
CRT 23	10	305	1,53	1,15	263	6,0	1,36	1,08	234	4,8	0,99	0,94	170	2,7	0,82	0,82	141	1,9			
	5	215	1,20	0,88	206	3,9	1,07	0,83	184	3,2	0,79	0,72	136	1,8	0,63	0,63	108	1,2			
	1	150	0,92	0,66	158	2,4	0,82	0,62	141	2,0	0,61	0,54	105	1,2	0,47	0,47	81	0,7			
CRT 33	10	450	2,56	1,84	440	22,4	2,30	1,73	396	18,3	1,74	1,52	299	11,1	1,33	1,33	229	6,8			
	5	325	2,02	1,42	347	14,7	1,81	1,34	311	12,1	1,38	1,17	237	7,3	1,03	1,03	177	4,3			
	1	220	1,47	1,02	253	8,5	1,33	0,96	229	7,0	1,01	0,84	174	4,3	0,74	0,74	127	2,4			
CRT 53	10	675	3,76	2,73	647	17,1	3,36	2,57	578	14,0	2,53	2,25	435	8,4	1,97	1,97	339	5,3			
	5	460	2,82	2,00	485	10,3	2,53	1,88	435	8,5	1,92	1,64	330	5,1	1,44	1,44	248	3,1			
	1	295	1,96	1,36	337	5,5	1,77	1,28	304	4,5	1,35	1,12	232	2,8	0,99	0,99	170	1,6			
CRT 73	10	900	5,02	3,63	863	33,1	4,50	3,42	774	27,1	3,41	2,99	587	16,4	2,63	2,63	452	10,3			
	5	630	3,84	2,71	660	20,7	3,45	2,55	593	17,0	2,63	2,23	452	10,4	1,96	1,96	337	6,1			
	1	400	2,67	1,85	459	10,9	2,40	1,74	413	9,0	1,84	1,51	316	5,6	1,34	1,34	230	3,1			

Correction factors for different R.H.

R.H.	WT:	7/12°C	8/13°C	10/15°C	12/17°C
48%	Pc	0,95	0,94	1,00	1,00
	Ps	1,00	1,00	1,00	1,00
46%	Pc	0,90	0,88	1,00	1,00
	Ps	1,00	1,00	1,00	1,00

LEGEND

- WT = Water temperature
- Pc = Cooling total emission
- Ps = Cooling sensible emission
- Qw = Water flow
- Dp(c) = Water pressure drop
- Vdc = Inverter Power
- Qv = Air flow

Cooling emission of 3 row coil

Entering air temperature: 26°C – R.H.: 50%

MODEL ECM	Vdc	WT: 7/12 °C					WT: 8/13 °C				WT: 10/15 °C				WT: 12/17 °C			
		Qv	Pc	Ps	Qw	Dp(c)	Pc	Ps	Qw	Dp(c)	Pc	Ps	Qw	Dp(c)	Pc	Ps	Qw	Dp(c)
		m³/h	kW	kW	l/h	kPa	kW	kW	l/h	kPa	kW	kW	l/h	kPa	kW	kW	l/h	kPa
CRT 13	10	240	0,94	0,80	162	2,0	0,81	0,75	139	1,5	0,65	0,65	112	1,0	0,54	0,54	93	0,7
	5	165	0,72	0,59	124	1,3	0,63	0,55	108	1,0	0,48	0,48	83	0,6	0,40	0,40	69	0,4
	1	105	0,53	0,41	91	0,7	0,46	0,38	79	0,6	0,34	0,34	58	0,3	0,29	0,29	50	0,2
CRT 23	10	305	1,35	1,08	232	4,8	1,18	1,01	203	3,8	0,90	0,90	155	2,3	0,75	0,75	129	1,6
	5	215	1,06	0,83	182	3,2	0,93	0,77	160	2,5	0,69	0,69	119	1,4	0,57	0,57	98	1,0
	1	150	0,81	0,62	139	2,0	0,71	0,58	122	1,6	0,50	0,49	86	0,8	0,43	0,43	74	0,6
CRT 33	10	450	2,29	1,74	394	18,3	2,02	1,63	347	14,6	1,45	1,41	249	8,0	1,22	1,22	210	5,8
	5	325	1,80	1,34	310	12,0	1,59	1,26	273	9,6	1,15	1,08	198	5,3	0,94	0,94	162	3,7
	1	220	1,32	0,96	227	6,9	1,17	0,90	201	5,6	0,85	0,78	146	3,2	0,68	0,68	117	2,1
CRT 53	10	675	3,35	2,57	576	13,9	2,95	2,41	507	11,1	2,10	2,08	361	6,0	1,80	1,80	310	4,5
	5	460	2,52	1,89	433	8,4	2,23	1,77	384	6,8	1,60	1,52	275	3,7	1,32	1,32	227	2,6
	1	295	1,76	1,28	303	4,5	1,56	1,20	268	3,6	1,13	1,03	194	2,0	0,90	0,90	155	1,3
CRT 73	10	900	4,48	3,42	771	27,1	3,96	3,21	681	21,7	2,84	2,78	488	11,9	2,41	2,41	415	8,8
	5	630	3,43	2,56	590	17,0	3,04	2,40	523	13,6	2,20	2,07	378	7,6	1,80	1,80	310	5,3
	1	400	2,39	1,74	411	8,9	2,12	1,63	365	7,2	1,55	1,40	267	4,1	1,23	1,23	212	2,7

Correction factors for different R.H.

R.H.	WT:	7/12°C	8/13°C	10/15°C	12/17°C
48%	Pc	0,95	0,94	1,00	1,00
	Ps	1,00	1,00	1,00	1,00
46%	Pc	0,90	0,88	1,00	1,00
	Ps	1,00	1,00	1,00	1,00

LEGEND

- WT = Water temperature
- Pc = Cooling total emission
- Ps = Cooling sensible emission
- Qw = Water flow
- Dp(c) = Water pressure drop
- Vdc = Inverter Power
- Qv = Air flow

Cooling emission of 3 row coil

Entering air temperature: 25°C – R.H.: 50%

MODEL ECM	Vdc	WT: 7/12 °C					WT: 8/13 °C					WT: 10/15 °C					WT: 12/17 °C				
		Qv	Pc	Ps	Qw	Dp(c)	Pc	Ps	Qw	Dp(c)	Pc	Ps	Qw	Dp(c)	Pc	Ps	Qw	Dp(c)			
		m³/h	kW	kW	l/h	kPa	kW	kW	l/h	kPa	kW	kW	l/h	kPa	kW	kW	l/h	kPa			
CRT 13	10	240	0,82	0,75	141	1,6	0,71	0,71	122	1,2	0,60	0,60	103	0,9	0,49	0,49	84	0,6			
	5	165	0,63	0,55	108	1,0	0,53	0,51	91	0,7	0,44	0,44	76	0,5	0,36	0,36	62	0,4			
	1	105	0,46	0,38	79	0,6	0,39	0,36	67	0,4	0,31	0,31	53	0,3	0,26	0,26	45	0,2			
CRT 23	10	305	1,18	1,01	203	3,8	1,01	0,94	174	2,8	0,82	0,82	141	2,0	0,67	0,67	115	1,4			
	5	215	0,93	0,77	160	2,5	0,80	0,72	138	1,9	0,63	0,63	108	1,2	0,52	0,52	89	0,9			
	1	150	0,71	0,58	122	1,6	0,61	0,54	105	1,2	0,47	0,47	81	0,7	0,39	0,39	67	0,5			
CRT 33	10	450	2,02	1,63	347	14,7	1,75	1,52	301	11,3	1,34	1,34	230	7,0	1,10	1,10	189	4,9			
	5	325	1,59	1,26	273	9,6	1,38	1,17	237	7,5	1,03	1,03	177	4,4	0,85	0,85	146	3,1			
	1	220	1,17	0,90	201	5,6	1,02	0,84	175	4,4	0,74	0,74	127	2,5	0,61	0,61	105	1,8			
CRT 53	10	675	2,95	2,42	507	11,1	2,55	2,26	439	8,6	1,98	1,98	341	5,4	1,63	1,63	280	3,8			
	5	460	2,22	1,77	382	6,8	1,93	1,65	332	5,2	1,45	1,45	249	3,1	1,20	1,20	206	2,2			
	1	295	1,55	1,20	267	3,6	1,35	1,12	232	2,8	0,99	0,99	170	1,6	0,82	0,82	141	1,1			
CRT 73	10	900	3,95	3,22	679	21,8	3,43	3,01	590	16,8	2,64	2,64	454	10,5	2,18	2,18	375	7,4			
	5	630	3,03	2,40	521	13,6	2,64	2,24	454	10,6	1,97	1,97	339	6,3	1,63	1,63	280	4,4			
	1	400	2,11	1,63	363	7,2	1,84	1,52	316	5,6	1,34	1,34	230	3,2	1,11	1,11	191	2,3			

Correction factors for different R.H.

R.H.	WT:	7/12°C	8/13°C	10/15°C	12/17°C
48%	Pc	0,95	0,94	1,00	1,00
	Ps	1,00	1,00	1,00	1,00
46%	Pc	0,90	0,88	1,00	1,00
	Ps	1,00	1,00	1,00	1,00

LEGEND

- WT = Water temperature
- Pc = Cooling total emission
- Ps = Cooling sensible emission
- Qw = Water flow
- Dp(c) = Water pressure drop
- Vdc = Inverter Power
- Qv = Air flow

Cooling emission of 3+1 row coil

Entering air temperature: 27°C – R.H.: 50%

MODEL ECM	Vdc	WT: 7/12 °C					WT: 8/13 °C				WT: 10/15 °C				WT: 12/17 °C			
		Qv m³/h	Pc kW	Ps kW	Qw l/h	Dp(c) kPa	Pc kW	Ps kW	Qw l/h	Dp(c) kPa	Pc kW	Ps kW	Qw l/h	Dp(c) kPa	Pc kW	Ps kW	Qw l/h	Dp(c) kPa
CRT 13+1	10	225	1,03	0,81	177	2,4	0,91	0,76	157	1,9	0,68	0,68	117	1,1	0,57	0,57	98	0,8
	5	150	0,78	0,59	134	1,5	0,69	0,56	119	1,2	0,50	0,48	86	0,6	0,42	0,42	72	0,5
	1	95	0,55	0,40	95	0,8	0,49	0,38	84	0,6	0,36	0,33	62	0,4	0,29	0,29	50	0,2
CRT 23+1	10	285	1,45	1,08	249	5,5	1,29	1,02	222	4,4	0,95	0,89	163	2,5	0,78	0,78	134	1,8
	5	195	1,10	0,80	189	3,4	0,98	0,75	169	2,7	0,73	0,66	126	1,6	0,58	0,58	100	1,0
	1	135	0,84	0,60	144	2,1	0,75	0,56	129	1,7	0,56	0,49	96	1,0	0,43	0,43	74	0,6
CRT 33+1	10	415	2,39	1,72	411	19,1	2,14	1,62	368	15,6	1,62	1,41	279	9,4	1,24	1,24	213	5,8
	5	295	1,84	1,29	316	12,0	1,65	1,22	284	9,9	1,25	1,06	215	6,0	0,93	0,93	160	3,5
	1	200	1,34	0,93	230	6,9	1,21	0,87	208	5,7	0,92	0,76	158	3,5	0,67	0,67	115	2,0
CRT 53+1	10	640	3,61	2,61	621	15,9	3,23	2,46	556	13,0	2,44	2,15	420	7,8	1,89	1,89	325	4,9
	5	420	2,62	1,85	451	9,1	2,35	1,74	404	7,4	1,78	1,52	306	4,5	1,33	1,33	229	2,7
	1	270	1,82	1,26	313	4,8	1,64	1,18	282	3,9	1,25	1,03	215	2,4	0,91	0,91	157	1,4
CRT 73+1	10	820	4,68	3,36	805	29,2	4,20	3,16	722	24,0	3,18	2,77	547	14,6	2,43	2,43	418	9,0
	5	565	3,54	2,49	609	17,9	3,18	2,34	547	14,7	2,43	2,04	418	9,0	1,80	1,80	310	5,3
	1	355	2,43	1,68	418	9,3	2,19	1,58	377	7,7	1,68	1,37	289	4,7	1,21	1,21	208	2,6

Correction factors for different R.H.

R.H.	WT:	7/12°C	8/13°C	10/15°C	12/17°C
48%	Pc	0,95	0,94	1,00	1,00
	Ps	1,00	1,00	1,00	1,00
46%	Pc	0,90	0,88	1,00	1,00
	Ps	1,00	1,00	1,00	1,00

LEGEND

- WT = Water temperature
- Pc = Cooling total emission
- Ps = Cooling sensible emission
- Qw = Water flow
- Dp(c) = Water pressure drop
- Vdc = Inverter Power
- Qv = Air flow

Cooling emission of 3+1 row coil

Entering air temperature: 26°C – R.H.: 50%

MODEL ECM	Vdc	WT: 7/12 °C					WT: 8/13 °C					WT: 10/15 °C					WT: 12/17 °C				
		Qv	Pc	Ps	Qw	Dp(c)	Pc	Ps	Qw	Dp(c)	Pc	Ps	Qw	Dp(c)	Pc	Ps	Qw	Dp(c)			
		m³/h	kW	kW	l/h	kPa	kW	kW	l/h	kPa	kW	kW	l/h	kPa	kW	kW	l/h	kPa			
CRT 13+1	10	225	0,90	0,76	155	1,9	0,78	0,71	134	1,4	0,62	0,62	107	1,0	0,52	0,52	89	0,7			
	5	150	0,69	0,56	119	1,2	0,60	0,52	103	0,9	0,46	0,46	79	0,6	0,38	0,38	65	0,4			
	1	95	0,49	0,38	84	0,6	0,42	0,35	72	0,5	0,31	0,31	53	0,3	0,26	0,26	45	0,2			
CRT 23+1	10	285	1,29	1,02	222	4,4	1,12	0,96	193	3,5	0,85	0,85	146	2,1	0,71	0,71	122	1,5			
	5	195	0,98	0,75	169	2,7	0,86	0,71	148	2,2	0,63	0,63	108	1,2	0,52	0,52	89	0,9			
	1	135	0,75	0,56	129	1,7	0,66	0,53	114	1,3	0,46	0,45	79	0,7	0,39	0,39	67	0,5			
CRT 33+1	10	415	2,13	1,62	366	15,6	1,88	1,52	323	12,4	1,35	1,31	232	6,8	1,14	1,14	196	5,0			
	5	295	1,64	1,22	282	9,8	1,45	1,14	249	7,9	1,05	0,98	181	4,4	0,85	0,85	146	3,0			
	1	200	1,20	0,88	206	5,7	1,06	0,82	182	4,6	0,78	0,71	134	2,6	0,62	0,62	107	1,7			
CRT 53+1	10	640	3,22	2,46	554	13,0	2,84	2,31	488	10,3	2,02	1,99	347	5,6	1,72	1,72	296	4,2			
	5	420	2,34	1,74	402	7,4	2,07	1,63	356	5,9	1,49	1,40	256	3,3	1,22	1,22	210	2,3			
	1	270	1,62	1,18	279	3,9	1,44	1,11	248	3,1	1,05	0,95	181	1,8	0,83	0,83	143	1,2			
CRT 73+1	10	820	4,18	3,17	719	23,9	3,69	2,97	635	19,2	2,65	2,57	456	10,6	2,23	2,23	384	7,7			
	5	565	3,16	2,35	544	14,7	2,80	2,20	482	11,8	2,03	1,89	349	6,6	1,65	1,65	284	4,5			
	1	355	2,18	1,58	375	7,6	1,94	1,48	334	6,1	1,42	1,27	244	3,5	1,11	1,11	191	2,3			

Correction factors for different R.H.

R.H.	WT:	7/12°C	8/13°C	10/15°C	12/17°C
48%	Pc	0,95	0,94	1,00	1,00
	Ps	1,00	1,00	1,00	1,00
46%	Pc	0,90	0,88	1,00	1,00
	Ps	1,00	1,00	1,00	1,00

LEGEND

- WT = Water temperature
- Pc = Cooling total emission
- Ps = Cooling sensible emission
- Qw = Water flow
- Dp(c) = Water pressure drop
- Vdc = Inverter Power
- Qv = Air flow

Cooling emission of 3+1 row coil

Entering air temperature: 25°C – R.H.: 50%

MODEL ECM	Vdc	WT: 7/12 °C					WT: 8/13 °C				WT: 10/15 °C				WT: 12/17 °C			
		Qv m³/h	Pc kW	Ps kW	Qw l/h	Dp(c) kPa	Pc kW	Ps kW	Qw l/h	Dp(c) kPa	Pc kW	Ps kW	Qw l/h	Dp(c) kPa	Pc kW	Ps kW	Qw l/h	Dp(c) kPa
CRT 13+1	10	225	0,78	0,71	134	1,4	0,67	0,67	115	1,1	0,57	0,57	98	0,8	0,46	0,46	79	0,6
	5	150	0,60	0,52	103	0,9	0,51	0,48	88	0,7	0,42	0,42	72	0,5	0,34	0,34	58	0,3
	1	95	0,42	0,35	72	0,5	0,36	0,33	62	0,4	0,29	0,29	50	0,2	0,24	0,24	41	0,2
CRT 23+1	10	285	1,12	0,96	193	3,5	0,96	0,89	165	2,6	0,78	0,78	134	1,8	0,64	0,64	110	1,2
	5	195	0,86	0,71	148	2,2	0,74	0,66	127	1,6	0,58	0,58	100	1,0	0,47	0,47	81	0,7
	1	135	0,66	0,53	114	1,3	0,56	0,49	96	1,0	0,43	0,43	74	0,6	0,36	0,36	62	0,4
CRT 33+1	10	415	1,88	1,52	323	12,5	1,63	1,42	280	9,6	1,24	1,24	213	5,9	1,03	1,03	177	4,2
	5	295	1,45	1,14	249	7,9	1,26	1,07	217	6,1	0,94	0,94	162	3,6	0,77	0,77	132	2,5
	1	200	1,06	0,82	182	4,6	0,92	0,76	158	3,6	0,67	0,67	115	2,0	0,56	0,56	96	1,4
CRT 53+1	10	640	2,83	2,31	487	10,4	2,45	2,16	421	8,0	1,89	1,89	325	5,0	1,56	1,56	268	3,5
	5	420	2,06	1,63	354	5,9	1,79	1,52	308	4,6	1,34	1,34	230	2,7	1,11	1,11	191	1,9
	1	270	1,44	1,11	248	3,1	1,25	1,03	215	2,4	0,91	0,91	157	1,4	0,75	0,75	129	1,0
CRT 73+1	10	820	3,69	2,98	635	19,2	3,20	2,78	550	14,9	2,44	2,44	420	9,1	2,02	2,02	347	6,4
	5	565	2,80	2,20	482	11,8	2,43	2,05	418	9,2	1,80	1,80	310	5,4	1,49	1,49	256	3,8
	1	355	1,93	1,48	332	6,1	1,68	1,38	289	4,8	1,22	1,22	210	2,7	1,01	1,01	174	1,9

Correction factors for different R.H.

R.H.	WT:	7/12°C	8/13°C	10/15°C	12/17°C
48%	Pc	0,95	0,94	1,00	1,00
	Ps	1,00	1,00	1,00	1,00
46%	Pc	0,90	0,88	1,00	1,00
	Ps	1,00	1,00	1,00	1,00

LEGEND

- WT = Water temperature
- Pc = Cooling total emission
- Ps = Cooling sensible emission
- Qw = Water flow
- Dp(c) = Water pressure drop
- Vdc = Inverter Power
- Qv = Air flow

Heating emission of 3 row coil

Entering air temperature: 20°C

MODEL ECM	Vdc	WT: 70/60 °C				WT: 60/50 °C			WT: 50/40 °C			WT: 50/45 °C			WT: 45/40 °C		
		Qv	Ph	Qw	Dp(c)	Ph	Qw	Dp(c)	Ph	Qw	Dp(c)	Ph	Qw	Dp(c)	Ph	Qw	Dp(c)
		m³/h	kW	l/h	kPa	kW	l/h	kPa	kW	l/h	kPa	kW	l/h	kPa	kW	l/h	kPa
CRT 13	10	240	2,63	226	2,8	1,99	171	1,8	1,35	116	0,9	1,61	277	4,2	1,29	222	2,9
	5	165	1,95	168	1,7	1,48	127	1,1	1,01	87	0,6	1,19	205	2,5	0,96	165	1,7
	1	105	1,39	120	0,9	1,06	91	0,6	0,73	63	0,3	0,85	146	1,4	0,69	119	1,0
CRT 23	10	305	3,41	293	5,6	2,59	223	3,6	1,78	153	1,9	2,08	358	8,4	1,68	289	5,9
	5	215	2,63	226	3,6	2,01	173	2,3	1,39	120	1,2	1,61	277	5,4	1,30	224	3,8
	1	150	2,01	173	2,2	1,54	132	1,4	1,07	92	0,8	1,23	212	3,4	1,00	172	2,4
CRT 33	10	450	5,32	458	18,6	4,08	351	12,0	2,84	244	6,6	3,25	559	27,9	2,64	454	19,6
	5	325	4,17	359	12,1	3,20	275	7,8	2,23	192	4,3	2,54	437	18,1	2,07	356	12,8
	1	220	3,05	262	7,0	2,34	201	4,5	1,64	141	2,5	1,86	320	10,5	1,51	260	7,4
CRT 53	10	675	7,92	681	14,6	6,07	522	9,4	4,21	362	5,1	4,83	831	21,9	3,92	674	15,4
	5	460	5,88	506	8,6	4,51	388	5,6	3,14	270	3,0	3,59	617	12,9	2,91	501	9,1
	1	295	4,07	350	4,5	3,13	269	2,9	2,19	188	1,6	2,49	428	6,8	2,02	347	4,8
CRT 73	10	900	10,31	887	27,0	7,91	680	17,4	5,51	474	9,6	6,29	1082	40,5	5,11	879	28,5
	5	630	7,74	666	16,3	5,95	512	10,6	4,15	357	5,8	4,73	814	24,5	3,84	660	17,3
	1	400	5,31	457	8,4	4,09	352	5,5	2,86	246	3,0	3,24	557	12,6	2,64	454	8,9

LEGEND

- WT = Water temperature
- Ph = Emission
- Qw = Water flow
- Dp(c) = Water pressure drop
- Vdc = Inverter Power
- Qv = Air flow

Heating emission of 3+1 row coil

Entering air temperature: 20°C

MODEL ECM	Vdc	WT: 80/70 °C			WT: 75/65 °C			WT: 70/60 °C			WT: 65/55 °C			WT: 60/50 °C			WT: 55/45 °C			
		Qv	Ph	Qw	Dp(c)	Ph	Qw	Dp(c)	Ph	Qw	Dp(c)	Ph	Qw	Dp(c)	Ph	Qw	Dp(c)	Ph	Qw	Dp(c)
		m³/h	kW	l/h	kPa	kW	l/h	kPa	kW	l/h	kPa	kW	l/h	kPa	kW	l/h	kPa	kW	l/h	kPa
CRT 13+1	10	225	1,38	119	2,6	1,24	107	2,2	1,09	94	1,8	0,95	82	1,4	0,80	69	1,1	0,66	57	0,8
	5	150	1,07	92	1,7	0,96	83	1,4	0,85	73	1,1	0,74	64	0,9	0,63	54	0,7	0,52	45	0,5
	1	95	0,78	67	1,0	0,70	60	0,8	0,62	53	0,7	0,54	46	0,5	0,46	40	0,4	0,38	33	0,3
CRT 23+1	10	285	1,97	169	5,7	1,77	152	4,8	1,57	135	3,9	1,37	118	3,1	1,18	101	2,4	0,98	84	1,8
	5	195	1,54	132	3,7	1,38	119	3,1	1,23	106	2,5	1,07	92	2,0	0,92	79	1,6	0,77	66	1,2
	1	135	1,22	105	2,5	1,10	95	2,1	0,98	84	1,7	0,86	74	1,4	0,73	63	1,1	0,61	52	0,8
CRT 33+1	10	415	3,13	269	16,6	2,82	243	14,1	2,51	216	11,6	2,21	190	9,4	1,90	163	7,4	1,60	138	5,5
	5	295	2,49	214	11,1	2,24	193	9,4	2,00	172	7,8	1,76	151	6,3	1,52	131	4,9	1,27	109	3,7
	1	200	1,91	164	7,0	1,73	149	5,9	1,54	132	4,9	1,35	116	4,0	1,17	101	3,1	0,98	84	2,3
CRT 53+1	10	640	4,59	395	6,4	4,13	355	5,4	3,67	316	4,4	3,21	276	3,6	2,75	237	2,8	2,30	198	2,0
	5	420	3,45	297	3,9	3,11	267	3,3	2,76	237	2,7	2,42	208	2,2	2,08	179	1,7	1,73	149	1,2
	1	270	2,55	219	2,3	2,30	198	1,9	2,05	176	1,6	1,79	154	1,3	1,54	132	1,0	1,29	111	0,7
CRT 73+1	10	820	5,88	506	11,6	5,30	456	9,8	4,72	406	8,1	4,14	356	6,5	3,56	306	5,1	2,99	257	3,8
	5	565	4,58	394	7,5	4,13	355	6,3	3,68	316	5,2	3,23	278	4,2	2,78	239	3,3	2,33	200	2,5
	1	355	3,32	286	4,2	2,99	257	3,6	2,67	230	3,0	2,34	201	2,4	2,02	174	1,9	1,70	146	1,4

LEGEND

- WT = Water temperature
- Ph = Emission
- Qw = Water flow
- Dp(c) = Water pressure drop
- Vdc = Inverter Power
- Qv = Air flow

Water pressure drop

3 row coil

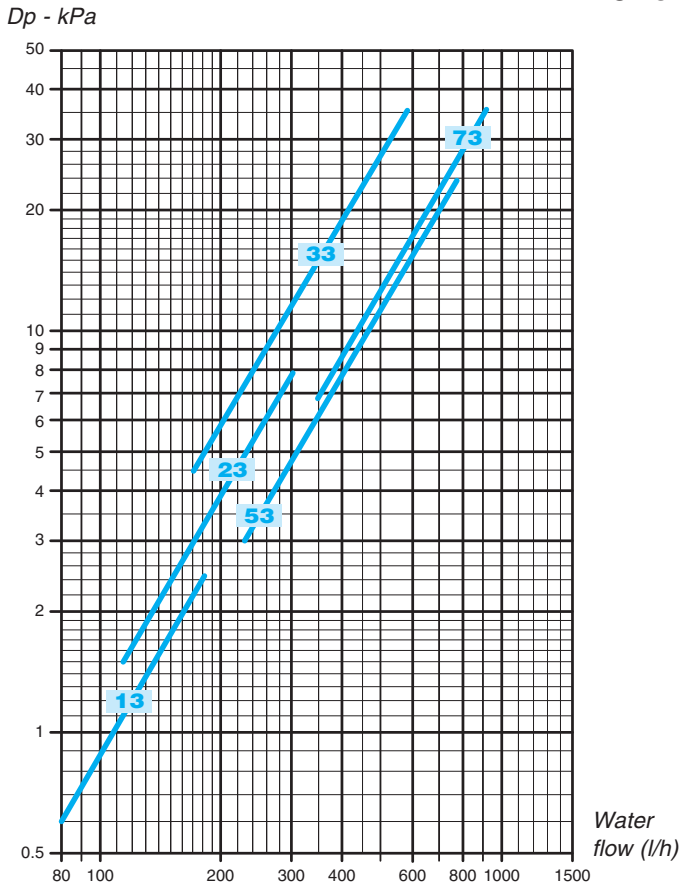

The water pressure drop figures refer to a mean water temperature of **10°C**; for different temperatures, multiply the pressure drop figures by the correction factors **K**.

°C	20	30	40	50	60	70	80
K	0,94	0,90	0,86	0,82	0,78	0,74	0,70

1 row additional coil

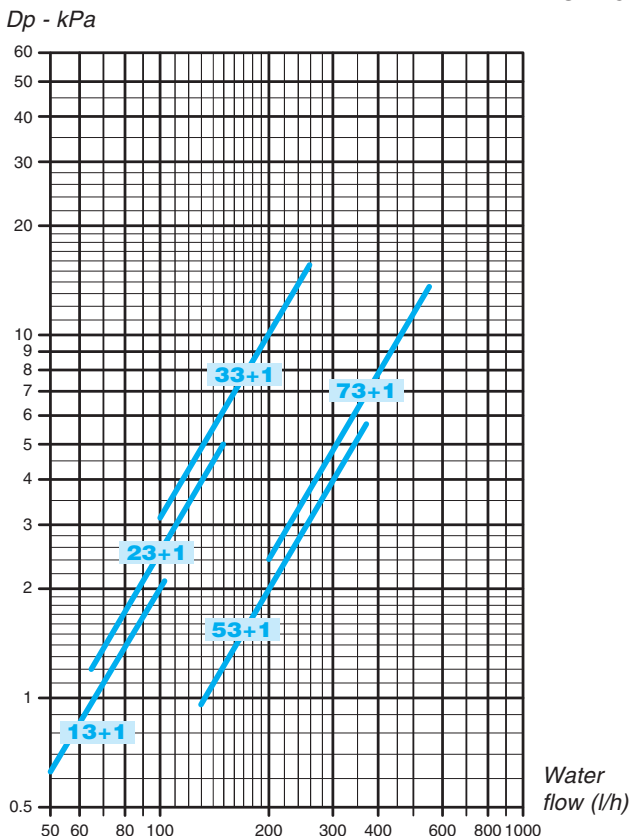

The water pressure drop figures refer to a mean water temperature of **65°C**; for different temperatures, multiply the pressure drop figures by the correction factors **K**.

°C	40	50	60	70	80
K	1,14	1,08	1,02	0,96	0,90

Construction features

Casing

Made from 1 mm galvanized steel insulated with polyolefin (PO) foam (class M1).

Filter

Polypropylene cellular fabric regenerating filter.
The filter frame of galvanized steel is inserted into special plastic sliding guides fastened to the internal structure for easy insertion and removal of the filter.

Fan assembly

The fans have aluminium or plastic blades directly keyed on the motor with double aspiration and they are dynamically and statically balanced during manufacture in order to have an extremely quiet operation.

Electronic motor

Three phase permanent magnet brushless electronic motor that is controlled with reconstructed current according to a BLAC sinusoidal wave. The inverter board that controls the motor operation is powered by 230 Volt, single-phase and, with a switching system, it generates a three-phase frequency modulated, wave form power supply. The electric power supply required for the machine is therefore single-phase with voltage of 230-240V and frequency of 50-60Hz.

Coil

It is manufactured from drawn copper tube and the aluminium fins are mechanically bonded onto the tube by an expansion process.
The coil has two 1/2 inch BSP internal connections and 1/8 inch BSP air vent and drain.

The coil is not suitable for use in corrosive atmosphere or in environments where aluminium may be subject to corrosion. The connections are on the left hand side looking from the air outlet of the unit (see picture).

On request or on site the connections can be moved to the other side.

Condensate collection tray

Made from plastic (ABS UL94 HB) with an "L"-shape fitted on the inner casing; the tray is insulated with polyolefin (PO) foam (class M1). The outside diameter of the condensate discharge pipe is 15mm.

Accessories and Controls

See pages 62 and 76.

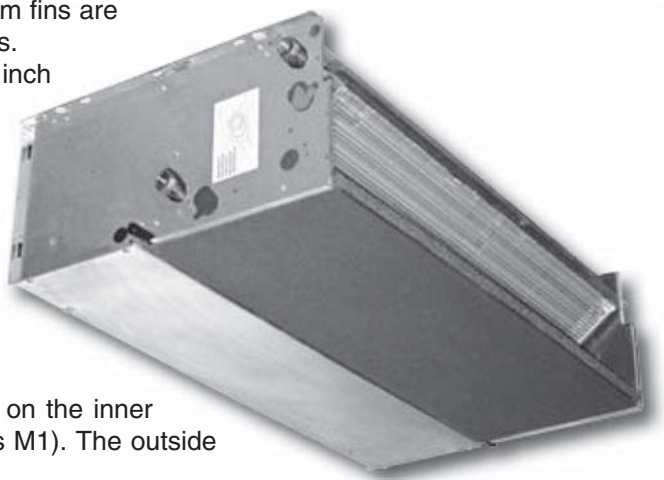
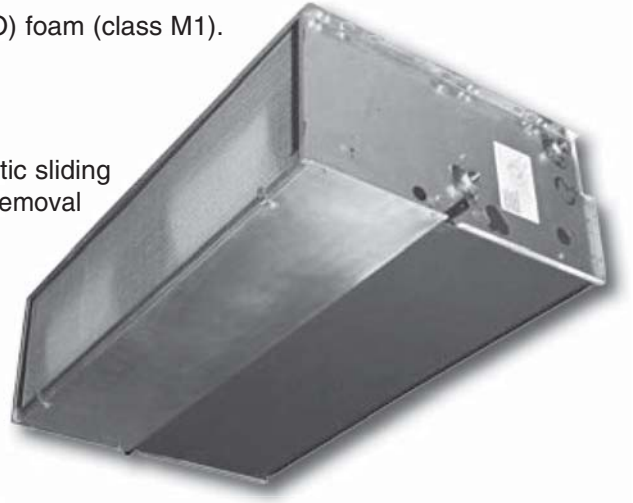

Compliant with ERP 2013 Regulation (EU) No. 327/2011

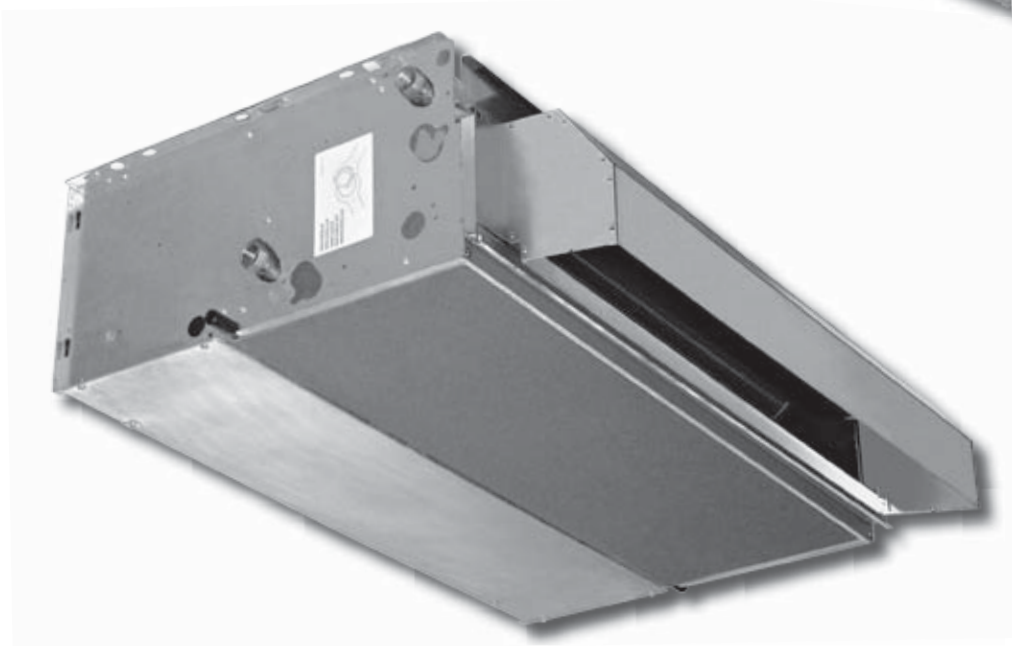
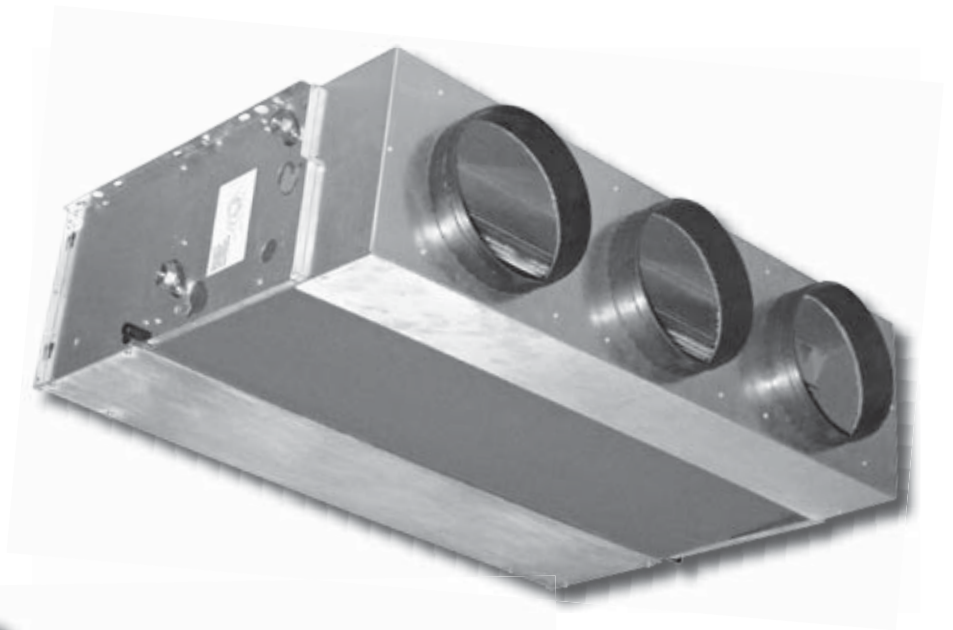
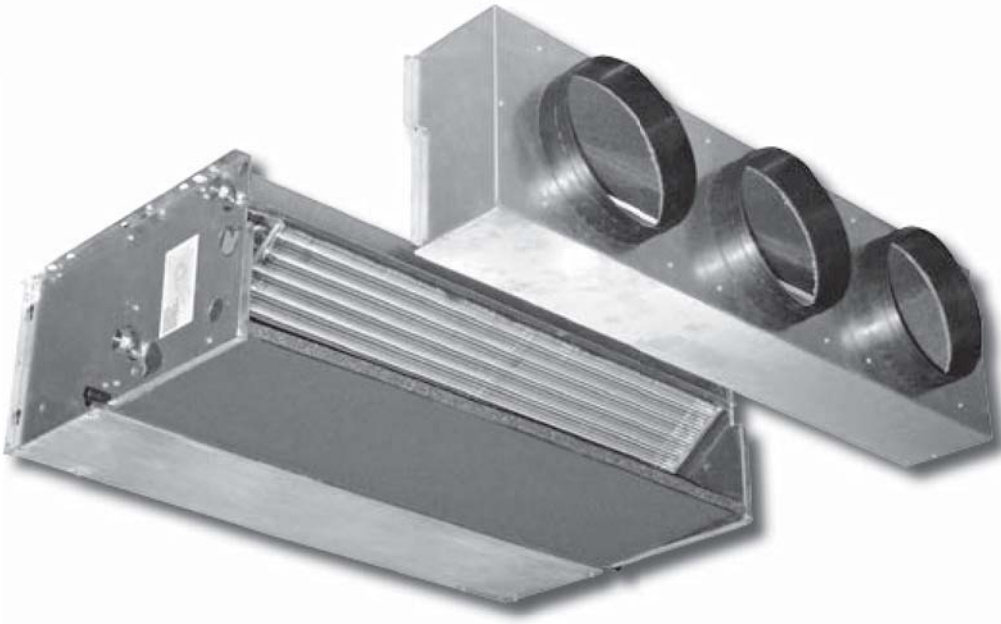

Dimensions, Weight, Water content

Vertical Installation

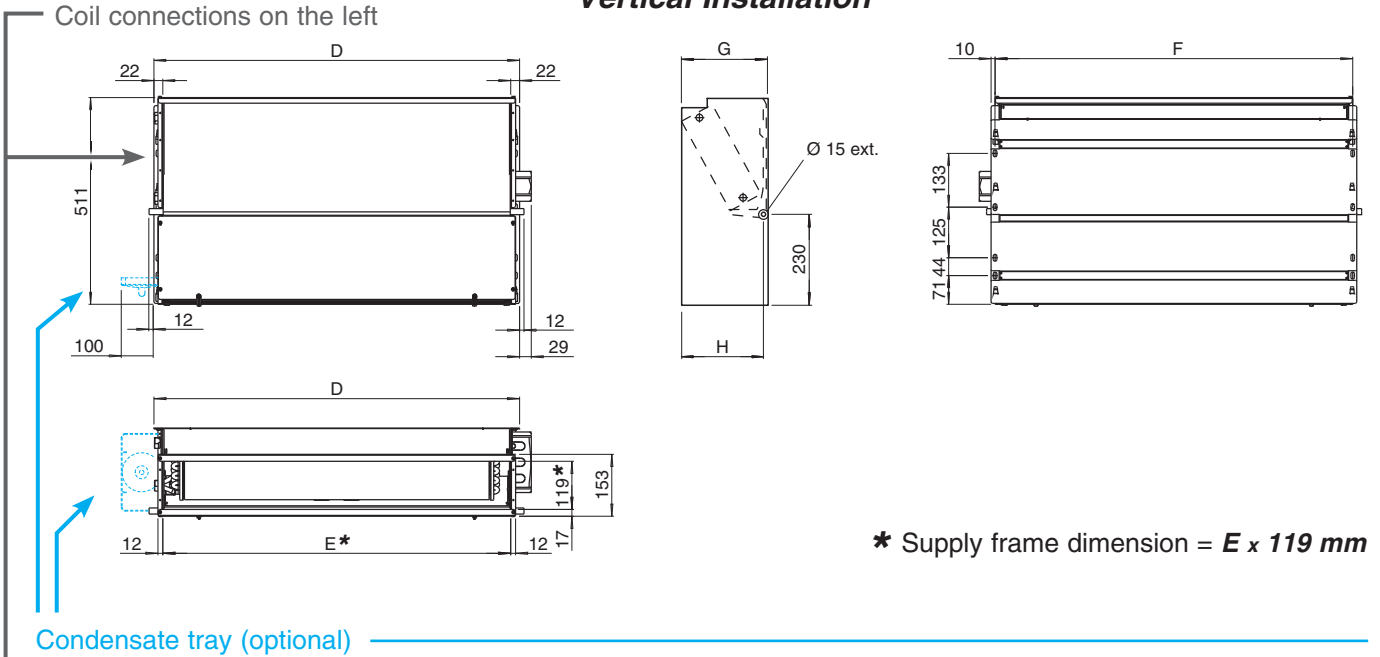

Horizontal Installation

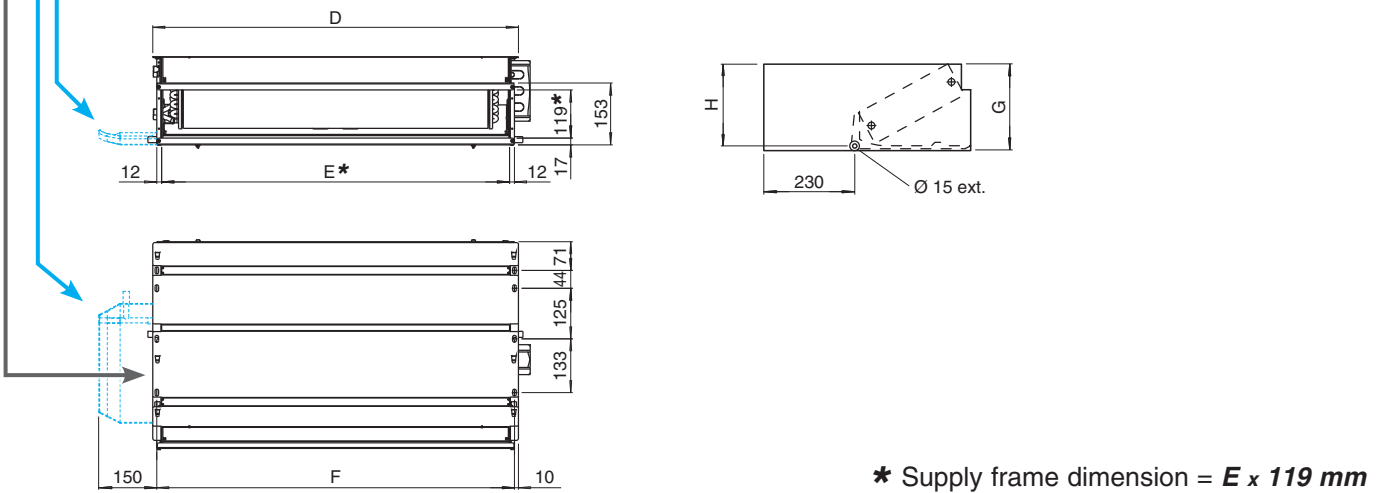

COIL CONNECTIONS

3 or 4 row coils

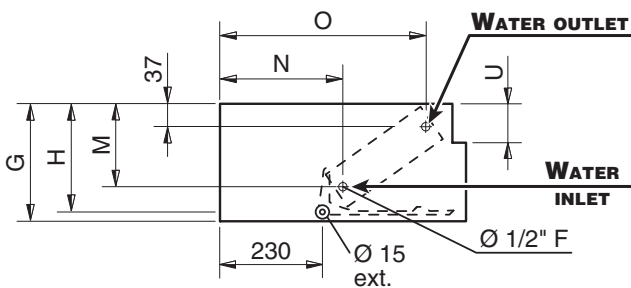

Heating additional coil (1 or 2 rows)

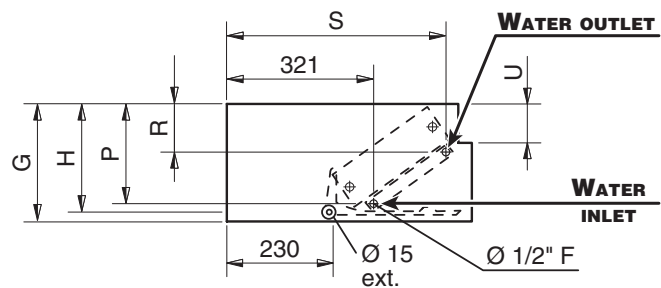

Dimensions, Weight, Water content

PACKAGING

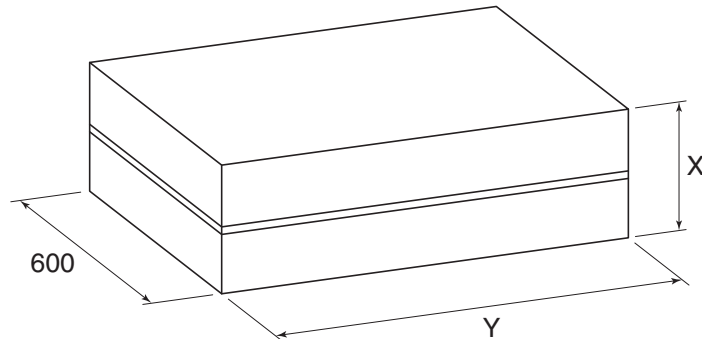

Dimensions (mm)

MODEL	1	2	3
<i>D</i>	689	904	1119
<i>E</i>	645	860	1075
<i>F</i>	669	884	1099
<i>G</i>	218	248	248
<i>H</i>	205	235	235
<i>M</i>	145	170	170
<i>N</i>	260	270	270
<i>O</i>	460	450	450
<i>P</i>	185	210	210
<i>R</i>	105	110	110
<i>S</i>	475	465	465
<i>U</i>	65	95	95
<i>X</i>	260	290	290
<i>Y</i>	820	1035	1250

Weight (kg)

		Weight with packaging			Weight without packaging		
MODEL		1	2	3	1	2	3
Rows	<i>3</i>	19	23	36	18	22	33
	<i>3+1</i>	25	29	44	23	27	41
	<i>3+2</i>	31	35	52	28	32	49
	<i>4</i>	22	26	42	20	24	39
	<i>4+1</i>	27	31	50	25	29	47

Water content (litres)

MODEL		1	2	3
Rows	<i>3</i>	0,9	1,6	1,9
	<i>4</i>	1,3	2,2	2,8
	<i>+1</i>	0,3	0,5	0,6
	<i>+2</i>	0,6	1,0	1,2

CRS-ECM UNITS WITH 3 AND 4 ROW COIL

2 pipe units.

The following standard rating conditions are used:

COOLING

Entering air temperature +27°C d.b. +19°C w.b.
Water temperature +7°C E.W.T. +12°C L.W.T.

HEATING

Entering air temperature +20°C
Entering water temperature +50°C
Water flow rate as for the cooling conditions

MODEL	CRS-ECM 13			CRS-ECM 23			CRS-ECM 33			
	MIN	MED	MAX	MIN	MED	MAX	MIN	MED	MAX	
Inverter power	5 (E)	7 (E)	9 (E)	4 (E)	6 (E)	8 (E)	4,5 (E)	6,5 (E)	8,5 (E)	
Speed										
Air flow (E)	m ³ /h	240	280	325	420	485	560	720	820	950
Available pressure (E)	Pa	35	50	65	35	50	65	35	50	65
Cooling total emission (E)	kW	1,55	1,76	1,98	2,66	2,98	3,33	4,21	4,64	5,16
Cooling sensible emission (E)	kW	1,16	1,33	1,51	2,02	2,28	2,57	3,27	3,64	4,10
Heating (E)	kW	1,91	2,18	2,48	3,25	3,46	4,10	5,33	5,94	6,68
Dp Cooling (E)	kPa	8,9	11,1	13,7	9,0	11,0	13,4	10,5	12,4	15,0
Dp Heating (E)	kPa	7,3	9,0	11,3	7,4	9,1	11,1	8,6	10,2	12,3
Fan (E)	W	24	32	43	30	44	64	50	71	102
Sound power outlet (E)	dB(A)	45	48	52	45	49	52	50	53	56
Sound power inlet + radiated (E)	dB(A)	52	54	58	51	55	58	56	60	63
Sound pressure outlet (*)	dB(A)	36	39	43	36	40	43	41	44	47
Sound pressure inlet + radiated (*)	dB(A)	43	45	49	42	46	49	47	51	54
Plenum code (E)		9066363			9069222			9066368		

MODEL	CRS-ECM 14			CRS-ECM 24			CRS-ECM 34			
	MIN	MED	MAX	MIN	MED	MAX	MIN	MED	MAX	
Inverter power	5 (E)	7 (E)	9 (E)	4 (E)	6 (E)	8 (E)	4,5 (E)	6,5 (E)	8,5 (E)	
Speed										
Air flow (E)	m ³ /h	240	280	325	420	485	560	720	820	950
Available pressure (E)	Pa	35	50	65	35	50	65	35	50	65
Cooling total emission (E)	kW	1,69	1,93	2,19	2,91	3,29	3,70	4,49	4,98	5,58
Cooling sensible emission (E)	kW	1,25	1,43	1,64	2,15	2,44	2,77	3,42	3,82	4,32
Heating (E)	kW	2,05	2,36	2,69	3,52	3,99	4,53	5,72	6,40	7,21
Dp Cooling (E)	kPa	5,4	6,8	8,5	15,1	18,7	23,0	9,1	10,9	13,3
Dp Heating (E)	kPa	4,4	5,5	7,0	12,4	15,4	19,0	7,5	9,0	10,9
Fan (E)	W	24	32	43	30	44	64	50	71	102
Sound power outlet (E)	dB(A)	45	48	52	45	49	52	50	53	56
Sound power inlet + radiated (E)	dB(A)	52	54	58	51	55	58	56	60	63
Sound pressure outlet (*)	dB(A)	36	39	43	36	40	43	41	44	47
Sound pressure inlet + radiated (*)	dB(A)	43	45	49	42	46	49	47	51	54
Plenum code (E)		9066363			9069222			9066368		

(E) = Eurovent certified performance.

(*) = The sound pressure levels are 9 dB(A) lower than the sound power levels and apply to the reverberant field of a 100 m³ room and a reverberation time of 0.5 sec.

EUROVENT Certification

CRS-ECM UNITS WITH 1 ROW ADDITIONAL COIL

4 pipe units.

The following standard rating conditions are used:

COOLING

Entering air temperature +27°C d.b. +19°C w.b.
Water temperature + 7°C E.W.T. +12°C L.W.T.

HEATING

Entering air temperature +20°C
Water temperature +70°C E.W.T. +60°C L.W.T.

MODEL	CRS-ECM 13+1			CRS-ECM 23+1			CRS-ECM 33+1			
	MIN	MED	MAX	MIN	MED	MAX	MIN	MED	MAX	
Inverter power	5 (E)	7 (E)	9 (E)	4 (E)	6 (E)	8 (E)	4,5 (E)	6,5 (E)	8,5 (E)	
Speed										
Air flow (E)	m ³ /h	240	280	325	420	485	560	720	820	950
Available pressure (E)	Pa	35	50	65	35	50	65	35	50	65
Cooling total emission (E)	kW	1,55	1,76	1,98	2,66	2,98	3,33	4,21	4,64	5,16
Cooling sensible emission (E)	kW	1,16	1,33	1,51	2,02	2,28	2,57	3,27	3,64	4,10
Heating (E)	kW	1,64	1,83	2,02	2,62	2,89	3,19	3,97	4,33	4,79
Dp Cooling (E)	kPa	8,9	11,1	13,7	9,0	11,0	13,4	10,5	12,4	15,0
Dp Heating (E)	kPa	5,5	6,6	8,0	3,4	4,1	4,9	6,0	7,0	8,3
Fan (E)	W	24	32	43	30	44	64	50	71	102
Sound power outlet (E)	dB(A)	45	48	52	45	49	52	50	53	56
Sound power inlet + radiated (E)	dB(A)	52	54	58	51	55	58	56	60	63
Sound pressure outlet (*)	dB(A)	36	39	43	36	40	43	41	44	47
Sound pressure inlet + radiated (*)	dB(A)	43	45	49	42	46	49	47	51	54
Plenum code (E)		9066363			9069222			9066368		

(E) = Eurovent certified performance.

(*) = The sound pressure levels are 9 dB(A) lower than the sound power levels and apply to the reverberant field of a 100 m³ room and a reverberation time of 0.5 sec.

Main performance and technical characteristics

2 pipe units. The following standard rating conditions are used:

COOLING

Entering air temperature +27°C d.b. +19°C w.b.
 Water temperature +7°C E.W.T. +12°C L.W.T.

HEATING

Entering air temperature +20°C
 Entering water temperature +50°C

AVAILABLE PRESSURE: 0 Pa

Water flow rate as for the cooling conditions

MODEL		CRS-ECM 13					CRS-ECM 23					CRS-ECM 33				
Vdc		1	3	5	7,5	10	1	3	5	7,5	10	1	3	5	7,5	10
Air flow	m³/h	350	425	515	625	730	610	760	920	1120	1250	770	985	1180	1425	1450
Cooling total emission	kW	2,10	2,43	2,80	3,21	3,57	3,55	4,18	4,78	5,45	5,86	4,43	5,30	6,01	6,82	6,90
Cooling sensible emission	kW	1,60	1,39	2,20	2,56	2,89	2,76	3,30	3,84	4,48	4,87	3,46	4,22	4,88	5,64	5,72
Heating	kW	2,62	3,08	3,59	4,18	4,70	4,40	5,24	6,08	7,05	7,65	5,63	6,87	7,91	9,14	9,26
Dp Cooling	kPa	15,2	19,7	25,2	32,1	38,6	15,0	20,0	25,3	32,0	36,2	11,5	15,7	19,6	24,5	25,0
Dp Heating	kPa	12,7	16,3	20,7	26,4	31,7	12,3	16,3	20,6	26,0	30,1	9,3	12,9	16,1	20,2	20,7
Fan	W	18	25,5	37	56	83	24	37	59	100	132	32	49	76	122	136
Sound power	Lw dB(A)	47	53	57	62	66	47	53	58	63	66	52	57	61	65	66
Sound pressure (*)	Lp dB(A)	38	44	48	53	57	38	44	49	54	57	43	48	52	56	57

MODEL		CRS-ECM 14					CRS-ECM 24					CRS-ECM 34				
Vdc		1	3	5	7,5	10	1	3	5	7,5	10	1	3	5	7,5	10
Air flow	m³/h	350	425	515	625	730	610	760	920	1120	1250	770	985	1180	1425	1450
Cooling total emission	kW	2,33	2,74	3,19	3,70	4,14	3,97	4,73	5,47	6,32	6,84	4,74	5,74	6,58	7,54	7,63
Cooling sensible emission	kW	1,75	2,08	2,45	2,88	3,28	2,98	3,60	4,22	4,96	5,41	3,62	4,46	5,17	6,02	6,10
Heating	kW	2,88	3,41	4,03	4,75	5,39	4,88	5,89	6,90	8,10	8,84	6,06	7,42	8,63	10,04	10,18
Dp Cooling	kPa	9,5	12,5	16,4	21,3	26,0	26,1	35,4	45,9	59,1	67,8	10,0	13,9	17,7	22,5	23,0
Dp Heating	kPa	7,7	10,1	13,6	17,5	21,5	21,7	29,4	37,8	48,7	56,1	8,2	11,4	14,7	18,6	19,0
Fan	W	18	25,5	37	56	83	24	37	59	100	132	32	49	76	122	136
Sound power	Lw dB(A)	47	53	57	62	66	47	53	58	63	66	52	57	61	65	66
Sound pressure (*)	Lp dB(A)	38	44	48	53	57	38	44	49	54	57	43	48	52	56	57

4 pipe units. The following standard rating conditions are used:

COOLING

Entering air temperature +27°C d.b. +19°C w.b.
 Water temperature +7°C E.W.T. +12°C L.W.T.

HEATING

Entering air temperature +20°C
 Water temperature +70°C E.W.T. +60°C L.W.T.

AVAILABLE PRESSURE: 0 Pa

MODEL		CRS-ECM 13+1					CRS-ECM 23+1					CRS-ECM 33+1				
Vdc		1	3	5	7,5	10	1	3	5	7,5	10	1	3	5	7,5	10
Air flow	m³/h	350	425	515	625	730	610	760	920	1120	1250	770	985	1180	1425	1450
Cooling total emission	kW	2,10	2,43	2,80	3,21	3,57	3,55	4,18	4,78	5,45	5,86	4,43	5,30	6,01	6,82	6,90
Cooling sensible emission	kW	1,60	1,39	2,20	2,56	2,89	2,76	3,30	3,84	4,48	4,87	3,46	4,22	4,88	5,64	5,72
Heating	kW	2,13	2,44	2,78	3,17	3,43	3,38	3,93	4,46	4,96	5,31	4,15	4,91	5,54	6,24	6,28
Dp Cooling	kPa	15,2	19,7	25,2	32,1	38,6	15,0	20,0	25,3	32,0	36,2	11,5	15,7	19,6	24,5	25,0
Dp Heating	kPa	8,7	11,0	13,9	17,5	20,2	5,4	7,0	8,8	10,6	11,9	6,5	8,7	10,8	13,3	13,4
Fan	W	18	25,5	37	56	83	24	37	59	100	132	32	49	76	122	136
Sound power	Lw dB(A)	47	53	57	62	66	47	53	58	63	66	52	57	61	65	66
Sound pressure (*)	Lp dB(A)	38	44	48	53	57	38	44	49	54	57	43	48	52	56	57

Vdc = Inverter Power

(*) = The sound pressure levels are 9 dB(A) lower than the sound power levels and apply to the reverberant field of a 100 m³ room and a reverberation time of 0.5 sec.

Operation limits

Highest water inlet temperature..... + 85 °C

Lowest water inlet temperature..... + 5 °C

for entering water temperatures below + 5°C, contact “SABIANA” technical department

Highest working pressure..... 1000 kPa (10 bars)

Water flow limits for 3 row coil (l/h)

MODEL	CRS-ECM 13	CRS-ECM 23	CRS-ECM 33
Lowest	100	150	200
Highest	750	1000	2000

Water flow limits for 4 row coil (l/h)

MODEL	CRS-ECM 14	CRS-ECM 24	CRS-ECM 34
Lowest	150	150	300
Highest	1000	1500	2250

Water flow limits for 1 row additional coil (l/h)

MODEL	CRS-ECM 1	CRS-ECM 2	CRS-ECM 3
Lowest	50	100	100
Highest	350	500	750

Water flow limits for 2 row additional coil (l/h)

MODEL	CRS-ECM 1	CRS-ECM 2	CRS-ECM 3
Lowest	100	100	100
Highest	350	500	750

Motor electrical data (max. absorption)

MODEL		CRS-ECM 1	CRS-ECM 2	CRS-ECM 3
230/1 50Hz	W	83	132	136

Cooling emission of 3 row coil

Entering air temperature: 27°C – R.H.: 50% – Available pressure: 0Pa

MODEL ECM	Vdc	WT: 7/12 °C					WT: 8/13 °C				WT: 10/15 °C				WT: 12/17 °C			
		Qv m³/h	Pc kW	Ps kW	Qw l/h	Dp(c) kPa	Pc kW	Ps kW	Qw l/h	Dp(c) kPa	Pc kW	Ps kW	Qw l/h	Dp(c) kPa	Pc kW	Ps kW	Qw l/h	Dp(c) kPa
CRS 13	10	730	3,84	2,86	660	44,0	3,43	2,70	590	35,8	2,56	2,37	440	21,1	2,08	2,08	358	14,4
	7,5	625	3,46	2,54	595	36,5	3,09	2,40	531	29,8	2,32	2,10	399	17,7	1,84	1,84	316	11,7
	5	515	3,02	2,19	519	28,7	2,70	2,06	464	23,5	2,03	1,80	349	14,0	1,58	1,58	272	8,9
	3	425	2,62	1,87	451	22,4	2,35	1,76	404	18,3	1,77	1,54	304	11,0	1,35	1,35	232	6,8
	1	350	2,26	1,60	389	17,2	2,02	1,50	347	14,1	1,53	1,31	263	8,6	1,15	1,15	198	5,1
CRS 23	10	1250	6,31	4,82	1085	41,3	5,62	4,55	967	33,5	4,17	4,01	717	19,5	3,50	3,50	602	14,2
	7,5	1120	5,88	4,44	1011	36,5	5,24	4,19	901	29,6	3,90	3,68	671	17,3	3,22	3,22	554	12,2
	5	920	5,15	3,82	886	28,9	4,60	3,59	791	23,5	3,43	3,15	590	13,9	2,77	2,77	476	9,4
	3	760	4,50	3,28	774	22,8	4,02	3,09	691	18,6	3,02	2,71	519	11,1	2,38	2,38	409	7,2
	1	610	3,83	2,75	659	17,1	3,43	2,59	590	14,0	2,58	2,26	444	8,4	1,99	1,99	342	5,2
CRS 33	10	1450	7,44	5,67	1280	28,6	6,62	5,34	1139	23,1	4,90	4,70	843	13,4	4,10	4,10	705	9,7
	7,5	1425	7,36	5,59	1266	28,0	6,55	5,28	1127	22,7	4,84	4,63	832	13,1	4,05	4,05	697	9,5
	5	1180	6,48	4,84	1115	22,4	5,78	4,56	994	18,2	4,29	3,99	738	10,6	3,50	3,50	602	7,3
	3	985	5,71	4,20	982	18,0	5,10	3,95	877	14,6	3,80	3,46	654	8,6	3,04	3,04	523	5,7
	1	770	4,77	3,44	820	13,1	4,27	3,24	734	10,7	3,20	2,83	550	6,3	2,49	2,49	428	4,0

Cooling emission of 3 row coil

Entering air temperature: 26°C – R.H.: 50% – Available pressure: 0Pa

MODEL ECM	Vdc	WT: 7/12 °C					WT: 8/13 °C				WT: 10/15 °C				WT: 12/17 °C			
		Qv m³/h	Pc kW	Ps kW	Qw l/h	Dp(c) kPa	Pc kW	Ps kW	Qw l/h	Dp(c) kPa	Pc kW	Ps kW	Qw l/h	Dp(c) kPa	Pc kW	Ps kW	Qw l/h	Dp(c) kPa
CRS 13	10	730	3,42	2,71	588	35,9	3,01	2,54	518	28,4	2,26	2,26	389	17,0	1,90	1,90	327	12,3
	7,5	625	3,08	2,40	530	29,8	2,71	2,25	466	23,7	2,01	2,01	346	13,7	1,68	1,68	289	10,0
	5	515	2,69	2,06	463	23,4	2,37	1,93	408	18,7	1,69	1,67	291	10,1	1,45	1,45	249	7,6
	3	425	2,33	1,77	401	18,3	2,06	1,66	354	14,6	1,47	1,43	253	8,0	1,24	1,24	213	5,8
	1	350	2,01	1,51	346	14,1	1,78	1,41	306	11,3	1,28	1,21	220	6,2	1,06	1,06	182	4,4
CRS 23	10	1250	5,61	4,56	965	33,6	4,92	4,29	846	26,5	3,81	3,81	655	16,7	3,19	3,19	549	12,0
	7,5	1120	5,23	4,19	900	29,7	4,59	3,94	789	23,4	3,51	3,51	604	14,4	2,94	2,94	506	10,4
	5	920	4,58	3,60	788	23,5	4,03	3,38	693	18,6	3,01	3,01	518	11,0	2,53	2,53	435	8,0
	3	760	4,01	3,10	690	18,6	3,53	2,90	607	14,7	2,59	2,59	445	8,4	2,17	2,17	373	6,1
	1	610	3,41	2,59	587	14,0	3,01	2,43	518	11,1	2,14	2,09	368	6,1	1,82	1,82	313	4,5
CRS 33	10	1450	6,61	5,35	1137	23,2	5,79	5,03	996	18,2	4,47	4,47	769	11,4	3,74	3,74	643	8,2
	7,5	1425	6,53	5,28	1123	22,7	5,73	4,96	986	17,9	4,41	4,41	759	11,1	3,69	3,69	635	8,0
	5	1180	5,76	4,57	991	18,2	5,06	4,28	870	14,4	3,81	3,81	655	8,6	3,19	3,19	549	6,2
	3	985	5,08	3,96	874	14,6	4,46	3,71	767	11,5	3,31	3,31	569	6,7	2,77	2,77	476	4,9
	1	770	4,24	3,24	729	10,6	3,74	3,04	643	8,4	2,65	2,61	456	4,5	2,27	2,27	390	3,4

Correction factors for different R.H.

R.H.	WT:	7/12°C	8/13°C	10/15°C	12/17°C
48%	Pc	0,95	0,94	1,00	1,00
	Ps	1,00	1,00	1,00	1,00
46%	Pc	0,90	0,88	1,00	1,00
	Ps	1,00	1,00	1,00	1,00

LEGEND

- WT = Water temperature
- Pc = Cooling total emission
- Ps = Cooling sensible emission
- Qw = Water flow
- Dp(c) = Water pressure drop
- Vdc = Inverter Power
- Qv = Air flow

NOTE

For air side pressure drop higher than 0Pa use correction factors at page 58 and 59.

Cooling emission of 3 row coil

Entering air temperature: 25°C – R.H.: 50% – Available pressure: 0Pa

MODEL ECM	Vdc	WT: 7/12 °C					WT: 8/13 °C					WT: 10/15 °C					WT: 12/17 °C				
		Qv	Pc	Ps	Qw	Dp(c)	Pc	Ps	Qw	Dp(c)	Pc	Ps	Qw	Dp(c)	Pc	Ps	Qw	Dp(c)			
		m³/h	kW	kW	l/h	kPa	kW	kW	l/h	kPa	kW	kW	l/h	kPa	kW	kW	l/h	kPa			
CRS 13	10	730	3,01	2,55	518	28,6	2,59	2,38	445	21,9	2,08	2,08	358	14,6	1,72	1,72	296	10,3			
	7,5	625	2,71	2,26	466	23,8	2,34	2,11	402	18,3	1,85	1,85	318	11,9	1,52	1,52	261	8,3			
	5	515	2,37	1,94	408	18,7	2,05	1,81	353	14,4	1,59	1,59	273	9,1	1,31	1,31	225	6,4			
	3	425	2,06	1,66	354	14,6	1,78	1,55	306	11,3	1,36	1,36	234	6,9	1,12	1,12	193	4,9			
	1	350	1,77	1,41	304	11,3	1,54	1,32	265	8,7	1,16	1,16	200	5,2	0,96	0,96	165	3,7			
CRS 23	10	1250	4,93	4,29	848	26,7	4,23	4,02	728	20,3	3,50	3,50	602	14,4	2,88	2,88	495	10,1			
	7,5	1120	4,59	3,95	789	23,6	3,95	3,69	679	18,0	3,23	3,23	556	12,4	2,66	2,66	458	8,7			
	5	920	4,03	3,39	693	18,7	3,47	3,16	597	14,3	2,77	2,77	476	9,5	2,28	2,28	392	6,7			
	3	760	3,53	2,91	607	14,8	3,05	2,72	525	11,4	2,38	2,38	409	7,3	1,97	1,97	339	5,1			
	1	610	3,00	2,43	516	11,2	2,60	2,27	447	8,6	1,99	1,99	342	5,3	1,64	1,64	282	3,7			
CRS 33	10	1450	5,79	5,03	996	18,4	4,96	4,71	853	13,9	4,10	4,10	705	9,8	3,37	3,37	580	6,9			
	7,5	1425	5,73	4,97	986	18,0	4,91	4,64	845	13,6	4,05	4,05	697	9,6	3,33	3,33	573	6,7			
	5	1180	5,05	4,29	869	14,5	4,34	4,01	746	11,0	3,51	3,51	604	7,4	2,88	2,88	495	5,2			
	3	985	4,46	3,72	767	11,6	3,84	3,47	660	8,9	3,04	3,04	523	5,8	2,50	2,50	430	4,1			
	1	770	3,73	3,04	642	8,5	3,22	2,84	554	6,5	2,49	2,49	428	4,1	2,05	2,05	353	2,9			

Correction factors for different R.H.

R.H.	WT:	7/12°C	8/13°C	10/15°C	12/17°C
48%	Pc	0,95	0,94	1,00	1,00
	Ps	1,00	1,00	1,00	1,00
46%	Pc	0,90	0,88	1,00	1,00
	Ps	1,00	1,00	1,00	1,00

LEGEND

- WT = Water temperature
- Pc = Cooling total emission
- Ps = Cooling sensible emission
- Qw = Water flow
- Dp(c) = Water pressure drop
- Vdc = Inverter Power
- Qv = Air flow

NOTE

For air side pressure drop higher than 0Pa use correction factors at page 58 and 59.

Cooling emission of 4 row coil

Entering air temperature: 27°C – R.H.: 50% – Available pressure: 0Pa

MODEL ECM	Vdc	WT: 7/12 °C					WT: 8/13 °C				WT: 10/15 °C				WT: 12/17 °C			
		Qv	Pc	Ps	Qw	Dp(c)	Pc	Ps	Qw	Dp(c)	Pc	Ps	Qw	Dp(c)	Pc	Ps	Qw	Dp(c)
		m³/h	kW	kW	l/h	kPa	kW	kW	l/h	kPa	kW	kW	l/h	kPa	kW	kW	l/h	kPa
CRS 14	10	730	4,47	3,26	769	29,7	3,99	3,07	686	24,2	2,99	2,68	514	14,4	2,36	2,36	406	9,4
	7,5	625	3,98	2,87	685	24,3	3,56	2,70	612	19,8	2,68	2,36	461	11,8	2,08	2,08	358	7,5
	5	515	3,43	2,44	590	18,7	3,07	2,29	528	15,3	2,32	2,00	399	9,2	1,77	1,77	304	5,6
	3	425	2,94	2,07	506	14,3	2,64	1,94	454	11,7	2,00	1,69	344	7,1	1,50	1,50	258	4,2
	1	350	2,51	1,75	432	10,8	2,25	1,64	387	8,9	1,71	1,43	294	5,4	1,26	1,26	217	3,1
CRS 24	10	1250	7,35	5,37	1264	77,1	5,59	5,07	961	63,1	4,97	4,45	855	38,0	3,92	3,92	674	24,6
	7,5	1120	6,80	4,93	1170	67,1	6,10	4,64	1049	55,1	4,61	4,07	793	33,3	3,59	3,59	617	21,1
	5	920	5,89	4,20	1013	52,1	5,28	3,95	908	42,8	4,01	3,46	690	26,0	3,06	3,06	526	15,9
	3	760	5,08	3,59	874	40,3	4,57	3,38	786	33,1	3,48	2,95	599	20,2	2,60	2,60	447	12,0
	1	610	4,27	2,97	734	29,6	3,84	2,80	660	24,4	2,93	2,44	504	15,0	2,15	2,15	370	8,6
CRS 34	10	1450	8,24	6,07	1417	26,3	7,34	5,71	1262	21,4	5,46	4,99	939	12,5	4,38	4,38	753	8,4
	7,5	1425	8,13	5,98	1398	25,8	7,25	5,63	1247	20,9	5,40	4,92	929	12,3	4,32	4,32	743	8,2
	5	1180	7,09	5,15	1219	20,2	6,33	4,84	1089	16,5	4,74	4,23	815	9,7	3,71	3,71	638	6,3
	3	985	6,19	4,44	1065	15,9	5,53	4,17	951	13,0	4,15	3,64	714	7,7	3,20	3,20	550	4,8
	1	770	5,11	3,61	879	11,3	4,57	3,39	786	9,3	3,45	2,95	593	5,6	2,62	2,62	451	3,4

Cooling emission of 4 row coil

Entering air temperature: 26°C – R.H.: 50% – Available pressure: 0Pa

MODEL ECM	Vdc	WT: 7/12 °C					WT: 8/13 °C				WT: 10/15 °C				WT: 12/17 °C			
		Qv	Pc	Ps	Qw	Dp(c)	Pc	Ps	Qw	Dp(c)	Pc	Ps	Qw	Dp(c)	Pc	Ps	Qw	Dp(c)
		m³/h	kW	kW	l/h	kPa	kW	kW	l/h	kPa	kW	kW	l/h	kPa	kW	kW	l/h	kPa
CRS 14	10	730	3,97	3,07	683	24,2	3,50	2,88	602	19,2	2,57	2,57	442	11,0	2,16	2,16	372	8,0
	7,5	625	3,55	2,70	611	19,8	3,12	2,53	537	15,7	2,22	2,18	382	8,5	1,90	1,90	327	6,4
	5	515	3,06	2,30	526	15,2	2,70	2,15	464	12,2	1,93	1,85	332	6,6	1,61	1,61	277	4,8
	3	425	2,63	1,95	452	11,7	2,32	1,82	399	9,3	1,67	1,57	287	5,2	1,37	1,37	236	3,6
	1	350	2,24	1,65	385	8,8	1,98	1,54	341	7,1	1,44	1,32	248	4,0	1,16	1,16	200	2,7
CRS 24	10	1250	6,56	5,08	1128	63,1	5,79	4,77	996	50,3	4,14	4,13	712	27,5	3,58	3,58	616	21,0
	7,5	1120	6,07	4,65	1044	55,0	5,37	4,37	924	44,0	3,85	3,78	662	24,1	3,28	3,28	564	18,0
	5	920	5,26	3,96	905	42,7	4,65	3,72	800	34,2	3,35	3,21	576	18,9	2,80	2,80	482	13,6
	3	760	4,54	3,38	781	33,0	4,02	3,17	691	26,5	2,92	2,74	502	14,8	2,38	2,38	409	10,3
	1	610	3,82	2,80	657	24,3	3,39	2,63	583	19,5	2,47	2,27	425	11,1	1,97	1,97	339	7,4
CRS 34	10	1450	7,31	5,72	1257	21,4	6,42	5,36	1104	16,9	4,77	4,77	820	9,9	3,99	3,99	686	7,1
	7,5	1425	7,22	5,64	1242	20,9	6,34	5,29	1090	16,5	4,70	4,70	808	9,6	3,94	3,94	678	6,9
	5	1180	6,30	4,85	1084	16,4	5,54	4,54	953	13,0	4,04	4,04	695	7,4	3,39	3,39	583	5,3
	3	985	5,50	4,18	946	13,0	4,85	3,91	834	10,3	3,43	3,37	590	5,5	2,92	2,92	502	4,1
	1	770	4,55	3,40	783	9,3	4,01	3,18	690	7,4	2,86	2,73	492	4,0	2,37	2,39	407	2,9

Correction factors for different R.H.

R.H.	WT:	7/12°C	8/13°C	10/15°C	12/17°C
48%	Pc	0,95	0,94	1,00	1,00
	Ps	1,00	1,00	1,00	1,00
46%	Pc	0,90	0,88	1,00	1,00
	Ps	1,00	1,00	1,00	1,00

LEGEND

- WT = Water temperature
- Pc = Cooling total emission
- Ps = Cooling sensible emission
- Qw = Water flow
- Dp(c) = Water pressure drop
- Vdc = Inverter Power
- Qv = Air flow

NOTE

For air side pressure drop higher than 0Pa use correction factors at page 58 and 59.

Cooling emission of 4 row coil

Entering air temperature: 25°C – R.H.: 50% – Available pressure: 0Pa

MODEL ECM	Vdc	WT: 7/12 °C					WT: 8/13 °C					WT: 10/15 °C					WT: 12/17 °C				
		Qv	Pc	Ps	Qw	Dp(c)	Pc	Ps	Qw	Dp(c)	Pc	Ps	Qw	Dp(c)	Pc	Ps	Qw	Dp(c)			
		m³/h	kW	kW	l/h	kPa	kW	kW	l/h	kPa	kW	kW	l/h	kPa	kW	kW	l/h	kPa			
CRS 14	10	730	3,50	2,88	602	19,3	3,02	2,69	519	14,8	2,37	2,37	408	9,5	1,95	1,95	335	6,7			
	7,5	625	3,12	2,54	537	15,8	2,70	2,37	464	12,1	2,08	2,08	358	7,6	1,72	1,72	296	5,4			
	5	515	2,69	2,16	463	12,2	2,33	2,01	401	9,4	1,77	1,77	304	5,7	1,46	1,46	251	4,0			
	3	425	2,31	1,83	397	9,3	2,01	1,70	346	7,2	1,50	1,50	258	4,3	1,24	1,24	213	3,0			
	1	350	1,98	1,54	341	7,1	1,72	1,43	296	5,5	1,27	1,27	218	3,2	1,05	1,05	181	2,2			
CRS 24	10	1250	5,79	4,78	996	50,6	5,02	4,47	863	39,1	3,93	3,93	676	25,1	3,25	3,25	559	17,7			
	7,5	1120	5,36	4,38	922	44,2	4,65	4,09	800	34,2	3,60	3,60	619	21,5	2,98	2,98	513	15,2			
	5	920	4,64	3,73	798	34,3	4,03	3,48	693	26,6	3,06	3,06	526	16,2	2,54	2,54	437	11,4			
	3	760	4,01	3,18	690	26,6	3,49	2,96	600	20,7	2,61	2,61	449	12,2	2,16	2,16	372	8,6			
	1	610	3,37	2,63	580	19,6	2,94	2,45	506	15,3	2,16	2,16	372	8,8	1,79	1,79	308	1,79			
CRS 34	10	1450	6,42	5,37	1104	17,0	5,52	5,01	949	12,9	4,38	4,38	753	8,5	3,60	3,60	619	5,9			
	7,5	1425	6,34	5,29	1090	16,6	5,45	4,94	937	12,7	4,32	4,32	743	8,3	3,56	3,56	612	5,8			
	5	1180	5,53	4,55	951	13,1	4,77	4,24	820	10,0	3,71	3,71	638	6,4	3,06	3,06	526	4,5			
	3	985	4,84	3,92	832	10,3	4,18	3,65	719	7,9	3,20	3,20	550	4,9	2,64	2,64	454	3,4			
	1	770	4,00	3,19	688	7,4	3,46	2,97	595	5,7	2,62	2,62	451	3,4	2,16	2,16	372	2,4			

Correction factors for different R.H.

R.H.	WT:	7/12°C	8/13°C	10/15°C	12/17°C
48%	Pc	0,95	0,94	1,00	1,00
	Ps	1,00	1,00	1,00	1,00
46%	Pc	0,90	0,88	1,00	1,00
	Ps	1,00	1,00	1,00	1,00

LEGEND

- WT = Water temperature
- Pc = Cooling total emission
- Ps = Cooling sensible emission
- Qw = Water flow
- Dp(c) = Water pressure drop
- Vdc = Inverter Power
- Qv = Air flow

NOTE

For air side pressure drop higher than 0Pa use correction factors at page 58 and 59.

Heating emission of 3 row coil

Entering air temperature: 20°C – Available pressure: 0Pa

MODEL ECM	Vdc	WT: 70/60 °C			WT: 60/50 °C			WT: 50/40 °C			WT: 50/45 °C			WT: 45/40 °C			
		Qv m³/h	Ph kW	Qw l/h	Dp(c) kPa	Ph kW	Qw l/h	Dp(c) kPa	Ph kW	Qw l/h	Dp(c) kPa	Ph kW	Qw l/h	Dp(c) kPa	Ph kW	Qw l/h	Dp(c) kPa
CRS 13	10	730	8,03	691	36,9	6,15	529	23,8	4,26	366	12,9	4,90	843	55,5	3,97	683	39,0
	7,5	625	7,11	611	29,8	5,45	469	19,2	3,78	325	10,5	4,34	746	44,8	3,52	605	31,5
	5	515	6,09	524	22,7	4,67	402	14,7	3,25	280	8,0	3,72	640	34,1	3,02	519	24,0
	3	425	5,21	448	17,2	3,99	343	11,1	2,78	239	6,1	3,18	547	25,9	2,58	444	18,2
	1	350	4,43	381	12,9	3,40	292	8,4	2,37	204	4,6	2,70	464	19,5	2,19	377	13,7
CRS 23	10	1250	13,06	1123	34,1	9,98	858	21,9	6,90	593	11,8	7,97	1371	51,2	6,45	1109	35,9
	7,5	1120	12,02	1034	29,4	9,19	790	18,9	6,36	547	10,3	7,34	1262	44,3	5,94	1022	31,1
	5	920	10,33	888	22,6	7,90	679	14,5	5,48	471	7,9	6,31	1085	33,9	5,11	879	23,8
	3	760	8,88	764	17,3	6,80	585	11,1	4,72	406	6,1	5,42	932	26,0	4,39	755	18,3
	1	610	7,42	638	12,6	5,69	489	8,1	3,95	340	4,4	4,53	779	19,0	3,67	631	13,3
CRS 33	10	1450	15,89	1367	24,9	12,13	1043	16,0	8,38	721	8,6	9,70	1668	37,5	7,84	1348	26,2
	7,5	1425	15,68	1348	24,3	11,97	1029	15,6	8,27	711	8,4	9,58	1648	36,6	7,74	1331	25,6
	5	1180	13,54	1164	18,8	10,34	889	12,1	7,16	616	6,5	8,27	1422	28,3	6,69	1151	19,8
	3	985	11,71	1007	14,6	8,96	771	9,4	6,21	534	5,1	7,15	1230	21,9	5,79	996	15,4
	1	770	9,57	823	10,2	7,33	630	6,6	5,08	437	3,6	5,84	1004	15,3	4,73	814	10,8

Heating emission of 4 row coil

Entering air temperature: 20°C – Available pressure: 0Pa

MODEL ECM	Vdc	WT: 70/60 °C			WT: 60/50 °C			WT: 50/40 °C			WT: 50/45 °C			WT: 45/40 °C			
		Qv m³/h	Ph kW	Qw l/h	Dp(c) kPa	Ph kW	Qw l/h	Dp(c) kPa	Ph kW	Qw l/h	Dp(c) kPa	Ph kW	Qw l/h	Dp(c) kPa	Ph kW	Qw l/h	Dp(c) kPa
CRS 14	10	730	9,18	789	24,2	7,03	605	15,6	4,88	420	8,5	5,61	965	36,4	4,54	781	25,6
	7,5	625	8,06	693	19,3	6,18	531	12,4	4,29	369	6,8	4,92	846	29,0	3,99	686	20,4
	5	515	6,82	587	14,4	5,24	451	9,3	3,65	314	5,1	4,17	717	21,6	3,38	581	15,2
	3	425	5,76	495	10,7	4,43	381	6,9	3,09	266	3,8	3,52	605	16,1	2,86	492	11,3
	1	350	4,85	417	7,9	3,73	321	5,1	2,60	224	2,8	2,96	509	11,8	2,41	415	8,4
CRS 24	10	1250	15,00	1290	62,1	11,52	991	40,2	8,02	690	22	9,16	1576	93,3	7,43	1278	65,8
	7,5	1120	13,73	1181	53,1	10,54	906	34,4	7,35	632	18,8	8,38	1441	79,8	6,80	1170	56,3
	5	920	11,67	1004	39,9	8,96	771	25,8	6,26	538	14,2	7,13	1226	59,9	5,79	996	42,3
	3	760	9,92	853	30,0	7,63	656	19,4	5,33	458	10,7	6,06	1042	45,0	4,92	846	31,8
	1	610	8,19	704	21,4	6,31	543	13,9	4,41	379	7,7	5,01	862	32,2	4,07	700	22,8
CRS 34	10	1450	17,44	1500	22,6	13,33	1146	14,5	9,22	793	7,9	10,65	1832	34,0	8,62	1483	23,9
	7,5	1425	17,19	1478	22,1	13,14	1130	14,2	9,10	783	7,7	10,50	1806	33,2	8,50	1462	23,3
	5	1180	14,71	1265	16,8	11,26	968	10,8	7,80	671	5,9	8,99	1546	25,2	7,28	1252	17,7
	3	985	12,63	1086	12,8	9,68	832	8,3	6,72	578	4,5	7,72	1328	19,3	6,25	1075	13,6
	1	770	10,27	883	8,9	7,88	678	5,8	5,48	471	3,1	6,28	1080	13,4	5,09	875	9,4

LEGEND

WT = Water temperature
 Ph = Emission
 Qw = Water flow
 Dp(c) = Water pressure drop
 Vdc = Inverter Power
 Qv = Air flow

NOTE

For air side
 pressure drop higher
 than 0Pa use
 correction factors
 at page 58 and 59.

Heating emission of 1 row additional coil

Entering air temperature: 20°C – Available pressure: 0Pa

MODEL ECM	Vdc	WT: 80/70 °C			WT: 75/65 °C			WT: 70/60 °C			WT: 65/55 °C			WT: 60/50 °C			WT: 55/45 °C			
		Qv	Ph	Qw	Dp(c)	Ph	Qw	Dp(c)	Ph	Qw	Dp(c)	Ph	Qw	Dp(c)	Ph	Qw	Dp(c)	Ph	Qw	Dp(c)
		m³/h	kW	l/h	kPa	kW	l/h	kPa	kW	l/h	kPa	kW	l/h	kPa	kW	l/h	kPa	kW	l/h	kPa
CRS 1	10	730	4,28	368	28,8	3,85	331	24,4	3,43	295	20,2	3,01	259	16,3	2,59	223	12,7	2,18	187	9,5
	7,5	625	3,94	339	25,0	3,56	306	21,1	3,17	273	17,5	2,78	239	14,1	2,39	206	11,0	2,01	173	8,2
	5	515	3,46	298	19,9	3,12	268	16,8	2,78	239	13,9	2,44	210	11,2	2,10	181	8,8	1,76	151	6,6
	3	425	3,03	261	15,7	2,73	235	13,3	2,44	210	11,0	2,14	184	8,9	1,84	158	7,0	1,55	133	5,2
	1	350	2,65	228	12,4	2,39	206	10,5	2,13	183	8,7	1,87	161	7,0	1,61	138	5,5	1,36	117	4,1
CRS 2	10	1250	6,65	572	17,2	5,98	514	14,5	5,31	457	11,9	4,64	399	9,6	3,97	341	7,4	3,3	284	5,4
	7,5	1120	6,21	534	15,3	5,58	480	12,9	4,96	427	10,6	4,33	372	8,5	3,71	319	6,6	3,09	266	4,8
	5	920	5,59	481	12,7	5,02	432	10,7	4,46	384	8,8	3,90	335	7,1	3,34	287	5,5	2,79	240	4,0
	3	760	4,92	423	10,2	4,43	381	8,5	3,93	338	7,0	3,44	296	5,7	2,95	254	4,4	2,46	212	3,2
	1	610	4,23	364	7,8	3,81	328	6,6	3,38	291	5,4	2,96	255	4,3	2,54	218	3,4	2,12	182	2,5
CRS 3	10	1450	7,83	673	19,2	7,05	606	16,2	6,28	540	13,4	5,50	473	10,8	4,73	407	8,4	3,96	341	6,3
	7,5	1425	7,78	669	19,0	7,01	603	16,0	6,24	537	13,3	5,47	470	10,7	4,70	404	8,3	3,94	339	6,2
	5	1180	6,91	594	15,4	6,22	535	13,0	5,54	476	10,8	4,86	418	8,7	4,18	359	6,8	3,5	301	5,0
	3	985	6,11	525	12,4	5,51	474	10,5	4,91	422	8,7	4,30	370	7,0	3,70	318	5,5	3,1	267	4,1
	1	770	5,17	445	9,2	4,66	401	7,8	4,15	357	6,5	3,64	313	5,2	3,13	269	4,1	2,63	226	3,0

Heating emission of 2 row additional coil

Entering air temperature: 20°C – Available pressure: 0Pa

MODEL ECM	Vdc	WT: 65/55 °C			WT: 60/50 °C			WT: 55/45 °C			WT: 50/40 °C			WT: 45/40 °C			WT: 45/35 °C			
		Qv	Ph	Qw	Dp(c)	Ph	Qw	Dp(c)	Ph	Qw	Dp(c)	Ph	Qw	Dp(c)	Ph	Qw	Dp(c)	Ph	Qw	Dp(c)
		m³/h	kW	l/h	kPa	kW	l/h	kPa	kW	l/h	kPa	kW	l/h	kPa	kW	l/h	kPa	kW	l/h	kPa
CRS 1	10	730	5,22	449	7,5	4,49	386	5,9	3,77	324	4,4	3,05	262	3,1	2,92	502	9,7	2,33	200	2,0
	7,5	625	4,69	403	6,3	4,04	347	4,9	3,40	292	3,7	2,75	237	2,6	2,62	451	8,1	2,10	181	1,6
	5	515	4,10	353	4,9	3,53	304	3,9	2,97	255	2,9	2,41	207	2,0	2,29	394	6,4	1,84	158	1,3
	3	425	3,57	307	3,9	3,08	265	3,0	2,59	223	2,3	2,10	181	1,6	1,99	342	5,0	1,61	138	1,0
	1	350	3,09	266	3,0	2,67	230	2,3	2,24	193	1,8	1,82	157	1,2	1,73	298	3,9	1,40	120	0,8
CRS 2	10	1250	8,50	731	24,7	7,35	632	19,4	6,19	532	14,6	5,04	433	10,3	4,76	819	32,0	3,88	334	6,7
	7,5	1120	7,91	680	21,7	6,83	587	17,1	5,76	495	12,9	4,69	403	9,1	4,42	760	28,1	3,61	310	5,9
	5	920	6,92	595	17,2	5,98	514	13,5	5,05	434	10,2	4,11	353	7,2	3,87	666	22,2	3,17	273	4,7
	3	760	6,06	521	13,6	5,24	451	10,7	4,42	380	8,1	3,60	310	5,7	3,39	583	17,6	2,78	239	3,7
	1	610	5,17	445	10,3	4,47	384	8,1	3,77	324	6,1	3,08	265	4,3	2,89	497	13,3	2,38	205	2,8
CRS 3	10	1450	10,32	888	47,3	8,94	769	37,3	7,55	649	28,2	6,17	531	20,1	5,78	994	61,2	4,78	411	13,1
	7,5	1425	10,20	877	46,3	8,83	759	36,5	7,47	642	27,6	6,10	525	19,7	5,71	982	60,0	4,73	407	12,8
	5	1180	8,97	771	37,0	7,77	668	29,1	6,57	565	22,0	5,37	462	15,7	5,03	865	47,8	4,17	359	10,3
	3	985	7,91	680	29,6	6,85	589	23,4	5,80	499	17,7	4,74	408	12,6	4,43	762	38,3	3,68	316	8,2
	1	770	6,62	569	21,6	5,73	493	17,1	4,85	417	12,9	3,97	341	9,2	3,71	638	28,0	3,09	266	6,0

LEGEND

WT = Water temperature
 Ph = Emission
 Qw = Water flow
 Dp(c) = Water pressure drop
 Vdc = Inverter Power
 Qv = Air flow

NOTE

For air side
 pressure drop higher
 than 0Pa use
 correction factors
 at page 58 and 59.

**Air flow and emission correction factors
with different available pressure**

MODEL ECM		EMISSION CORRECTION FACTORS FOR HIGH SPEED FIGURES AT 10 V SIGNAL																												
		Vdc	Qv (m³/h)										K1										K2							
			Ap (Pa)										Ap (Pa)										Ap (Pa)							
		0	10	20	30	40	50	60	70	80	0	10	20	30	40	50	60	70	80	0	10	20	30	40	50	60	70	80		
CRS 1	10	730	695	648	595	540	480	423	355	280	1,00	0,97	0,92	0,87	0,81	0,75	0,68	0,59	0,49	1,00	0,96	0,91	0,85	0,79	0,72	0,65	0,56	0,46		
	9,5	720	670	620	570	510	450	387	315	240	0,99	0,94	0,89	0,84	0,78	0,71	0,63	0,54	0,43	0,99	0,94	0,88	0,82	0,76	0,68	0,60	0,51	0,40		
	9	692	647	595	540	480	420	350	275	190	0,96	0,92	0,87	0,81	0,75	0,68	0,59	0,48	0,36	0,96	0,91	0,85	0,79	0,72	0,65	0,56	0,45	0,33		
	8,5	661	620	570	510	450	385	310	280	125	0,93	0,89	0,84	0,78	0,71	0,63	0,53	0,49	0,25	0,93	0,88	0,82	0,76	0,68	0,60	0,50	0,46	0,23		
	8	650	600	543	485	420	355	273	180	-	0,92	0,87	0,82	0,75	0,68	0,59	0,48	0,34	-	0,91	0,86	0,79	0,73	0,65	0,56	0,45	0,31	-		
	7,5	625	575	520	460	395	317	230	137	-	0,90	0,85	0,79	0,72	0,64	0,54	0,42	0,27	-	0,89	0,83	0,77	0,70	0,61	0,51	0,39	0,24	-		
	7	692	550	492	430	360	280	185	-	-	0,96	0,82	0,76	0,69	0,60	0,49	0,35	-	-	0,96	0,80	0,73	0,66	0,57	0,46	0,32	-	-		
	6,5	573	520	465	400	320	235	130	-	-	0,85	0,79	0,73	0,65	0,55	0,43	0,26	-	-	0,83	0,77	0,70	0,62	0,52	0,40	0,23	-	-		
	6	555	500	440	367	285	180	-	-	-	0,83	0,77	0,70	0,61	0,50	0,34	-	-	-	0,81	0,74	0,67	0,58	0,47	0,31	-	-	-		
	5,5	540	476	410	332	245	140	-	-	-	0,81	0,74	0,66	0,56	0,44	0,27	-	-	-	0,79	0,71	0,63	0,53	0,41	0,25	-	-	-		
	5	515	450	380	296	200	-	-	-	-	0,78	0,71	0,63	0,51	0,37	-	-	-	-	0,76	0,68	0,60	0,48	0,34	-	-	-	-		
	4	472	400	320	226	105	-	-	-	-	0,74	0,65	0,55	0,41	0,21	-	-	-	-	0,71	0,62	0,52	0,38	0,19	-	-	-	-		
3	425	347	252	132	-	-	-	-	-	0,68	0,58	0,45	0,26	-	-	-	-	-	0,65	0,55	0,42	0,24	-	-	-	-	-			
2	384	295	187	-	-	-	-	-	-	0,63	0,51	0,35	-	-	-	-	-	-	0,60	0,48	0,32	-	-	-	-	-	-			
1	350	250	115	-	-	-	-	-	-	0,59	0,45	0,23	-	-	-	-	-	-	0,56	0,42	0,21	-	-	-	-	-	-			
CRS 2	10	1250	1195	1140	1075	1010	940	860	780	680	1,00	0,97	0,94	0,91	0,87	0,83	0,78	0,73	0,66	1,00	0,97	0,93	0,89	0,85	0,80	0,75	0,69	0,62		
	9,5	1245	1075	1115	1050	980	900	820	722	715	1,00	0,96	0,93	0,89	0,85	0,80	0,75	0,69	0,68	1,00	0,95	0,92	0,87	0,83	0,78	0,72	0,65	0,65		
	9	1220	1155	1090	1020	945	860	770	665	535	0,98	0,95	0,91	0,87	0,83	0,78	0,72	0,65	0,55	0,98	0,94	0,90	0,86	0,81	0,75	0,69	0,61	0,51		
	8,5	1200	1135	1065	990	907	815	715	593	440	0,97	0,94	0,90	0,86	0,81	0,75	0,68	0,59	0,47	0,97	0,93	0,88	0,84	0,78	0,72	0,65	0,55	0,43		
	8	1160	1092	1020	940	853	755	645	510	315	0,95	0,92	0,87	0,83	0,77	0,71	0,63	0,53	0,36	0,94	0,90	0,86	0,80	0,74	0,67	0,59	0,49	0,32		
	7,5	1120	1048	970	890	800	695	570	410	-	0,93	0,89	0,85	0,80	0,74	0,67	0,58	0,44	-	0,92	0,87	0,82	0,77	0,71	0,63	0,54	0,40	-		
	7	1080	1005	927	840	740	630	490	300	-	0,91	0,87	0,82	0,77	0,70	0,62	0,51	0,34	-	0,89	0,85	0,79	0,73	0,66	0,58	0,47	0,31	-		
	6,5	1040	960	880	785	685	560	400	-	-	0,89	0,84	0,79	0,73	0,66	0,57	0,44	-	-	0,87	0,82	0,76	0,70	0,62	0,53	0,40	-	-		
	6	1000	920	835	735	625	485	285	-	-	0,86	0,82	0,76	0,70	0,62	0,51	0,33	-	-	0,84	0,79	0,73	0,66	0,58	0,47	0,29	-	-		
	5,5	960	880	785	685	560	400	-	-	-	0,84	0,79	0,73	0,66	0,57	0,44	-	-	-	0,82	0,76	0,70	0,62	0,53	0,40	-	-	-		
	5	920	830	737	625	495	300	-	-	-	0,82	0,76	0,70	0,62	0,52	0,34	-	-	-	0,79	0,73	0,66	0,58	0,48	0,31	-	-	-		
	4	840	750	640	510	340	-	-	-	-	0,77	0,71	0,63	0,53	0,38	-	-	-	-	0,73	0,67	0,59	0,49	0,34	-	-	-	-		
3	760	655	535	370	-	-	-	-	-	0,71	0,64	0,55	0,41	-	-	-	-	-	0,68	0,60	0,51	0,37	-	-	-	-	-			
2	680	560	400	160	-	-	-	-	-	0,66	0,57	0,44	0,20	-	-	-	-	-	0,62	0,53	0,40	0,18	-	-	-	-	-			
1	610	475	280	-	-	-	-	-	-	0,61	0,50	0,32	-	-	-	-	-	-	0,57	0,46	0,29	-	-	-	-	-	-			
CRS 3	10	1450	1395	1350	1310	1260	1205	1145	1075	990	1,00	0,97	0,95	0,93	0,91	0,88	0,85	0,82	0,77	1,00	0,97	0,95	0,92	0,90	0,87	0,83	0,79	0,74		
	9,5	1445	1390	1345	1295	1245	1185	1115	1030	935	1,00	0,97	0,95	0,93	0,90	0,87	0,84	0,79	0,74	1,00	0,97	0,94	0,92	0,89	0,85	0,81	0,76	0,71		
	9	1440	1385	1340	1280	1225	1155	1075	975	850	0,99	0,97	0,95	0,92	0,89	0,86	0,82	0,76	0,69	0,99	0,96	0,94	0,91	0,88	0,84	0,79	0,73	0,65		
	8,5	1435	1380	1335	1270	1195	1110	1015	900	750	0,99	0,97	0,95	0,91	0,88	0,83	0,78	0,72	0,63	0,99	0,96	0,94	0,90	0,86	0,81	0,76	0,69	0,59		
	8	1430	1370	1305	1230	1145	1050	940	800	630	0,99	0,96	0,93	0,90	0,85	0,80	0,74	0,66	0,55	0,99	0,96	0,92	0,88	0,83	0,78	0,71	0,62	0,51		
	7,5	1425	1345	1265	1180	1085	970	845	690	500	0,99	0,95	0,91	0,87	0,82	0,76	0,69	0,59	0,46	0,99	0,94	0,90	0,85	0,80	0,73	0,65	0,55	0,42		
	7	1360	1290	1210	1120	1015	895	760	590	-	0,96	0,92	0,89	0,84	0,78	0,72	0,63	0,52	-	0,95	0,91	0,87	0,82	0,76	0,68	0,60	0,48	-		
	6,5	1320	1240	1160	1060	955	825	660	460	-	0,94	0,90	0,86	0,81	0,75	0,67	0,57	0,43	-	0,93	0,89	0,84	0,78	0,72	0,64	0,53	0,39	-		
	6	1270	1190	1100	995	880	735	570	-	-	0,91	0,88	0,83	0,77	0,71	0,62	0,51	-	-	0,90	0,86	0,81	0,74	0,67	0,58	0,47	-	-		
	5,5	1220	1140	1040	930	800	645	450	-	-	0,89	0,85	0,80	0,74	0,66	0,56	0,42	-	-	0,87	0,83	0,77	0,70	0,62	0,52	0,38	-	-		
	5	1180	1080	980	865	725	545	-	-	-	0,87	0,82	0,76	0,70	0,61	0,49	-	-	-	0,85	0,79	0,73	0,66	0,57	0,45	-	-	-		
	4	1080	982	870	730	560	350	-	-	-	0,82	0,77	0,70	0,62	0,50	0,34	-	-	-	0,79	0,74	0,67	0,58	0,46	0,31	-	-	-		
3	985	875	745	570	350	-	-	-	-	0,77	0,70	0,63	0,51	0,34	-	-	-	-	0,74	0,67	0,59	0,47	0,31	-	-	-	-			
2	890	760	595	-	-	-	-	-	-	0,71	0,63	0,53	-	-	-	-	-	-	0,68	0,60	0,49	-	-	-	-	-	-			
1	770	600	405	-	-	-	-	-	-	0,64	0,53	0,39	-	-	-	-	-	-	0,60	0,49	0,35	-	-	-	-	-	-			

LEGEND

- Qv = Air flow
- K1 = Correction factors for Total cooling emission
- K2 = Correction factors for Sensible cooling emission and Heating emission
- Ap = Available pressure
- Vdc = Inverter Power

Air flow table, correction factors for emission and Watts absorbed by the motor with different available pressures

MODEL ECM	Vdc	Qv (m³/h)										Qv %										W									
		Ap (Pa)										Ap (Pa)										Ap (Pa)									
		0	10	20	30	40	50	60	70	80	0	10	20	30	40	50	60	70	80	0	10	20	30	40	50	60	70	80			
CRS 1	10	730	695	648	595	540	480	423	355	280	1,00	0,95	0,89	0,82	0,74	0,66	0,58	0,49	0,38	80	77	73	68	63	59	54	49	44			
	9,5	720	670	620	570	510	450	387	315	240	0,99	0,92	0,85	0,78	0,70	0,62	0,53	0,43	0,33	75	71	67	63	58	53	49	44	40			
	9	692	647	595	540	480	420	350	275	190	0,95	0,89	0,82	0,74	0,66	0,58	0,48	0,38	0,26	69	65	61	57	53	49	44	40	35			
	8,5	661	620	570	510	450	385	310	280	125	0,91	0,85	0,78	0,70	0,62	0,53	0,42	0,38	0,17	63	60	56	52	48	44	39	38	30			
	8	650	600	543	485	420	355	273	180	-	0,89	0,82	0,74	0,66	0,58	0,49	0,37	0,25	-	59	55	51	47	43	40	35	31	-			
	7,5	625	575	520	460	395	317	230	137	-	0,86	0,79	0,71	0,63	0,54	0,43	0,32	0,19	-	54	51	47	43	39	35	31	27	-			
	7	692	550	492	430	360	280	185	-	-	0,95	0,75	0,67	0,59	0,49	0,38	0,25	-	-	55	46	43	39	35	32	27	-	-			
	6,5	573	520	465	400	320	235	130	-	-	0,78	0,71	0,64	0,55	0,44	0,32	0,18	-	-	44	42	39	36	32	28	24	-	-			
	6	555	500	440	367	285	180	-	-	-	0,76	0,68	0,60	0,50	0,39	0,25	-	-	-	41	38	35	32	29	25	-	-	-			
	5,5	540	476	410	332	245	140	-	-	-	0,74	0,65	0,56	0,45	0,34	0,19	-	-	-	38	35	32	29	25	22	-	-	-			
	5	515	450	380	296	200	-	-	-	-	0,71	0,62	0,52	0,41	0,27	-	-	-	-	35	32	29	26	22	-	-	-	-			
	4	472	400	320	226	105	-	-	-	-	0,65	0,55	0,44	0,31	0,14	-	-	-	-	29	26	23	20	17	-	-	-	-			
3	425	347	252	132	-	-	-	-	-	0,58	0,48	0,35	0,18	-	-	-	-	-	24	21	18	15	-	-	-	-	-				
2	384	295	187	-	-	-	-	-	-	0,53	0,40	0,26	-	-	-	-	-	-	20	17	15	-	-	-	-	-	-				
1	350	250	115	-	-	-	-	-	-	0,48	0,34	0,16	-	-	-	-	-	-	17	14	12	-	-	-	-	-	-				
CRS 2	10	1250	1195	1140	1075	1010	940	860	780	680	1,00	0,96	0,91	0,86	0,81	0,75	0,69	0,62	0,54	132	132	131	125	119	113	106	99	91			
	9,5	1245	1075	1115	1050	980	900	820	722	715	1,00	0,94	0,89	0,84	0,78	0,72	0,66	0,58	0,57	132	128	123	117	111	104	97	89	89			
	9	1220	1155	1090	1020	945	860	770	665	535	0,98	0,92	0,87	0,82	0,76	0,69	0,62	0,53	0,43	126	121	115	109	103	96	89	81	71			
	8,5	1200	1135	1065	990	907	815	715	593	440	0,96	0,91	0,85	0,79	0,73	0,65	0,57	0,47	0,35	119	113	107	101	94	87	80	71	61			
	8	1160	1092	1020	940	853	755	645	510	315	0,93	0,87	0,82	0,75	0,68	0,60	0,52	0,41	0,25	109	103	97	91	85	78	70	61	49			
	7,5	1120	1048	970	890	800	695	570	410	-	0,90	0,84	0,78	0,71	0,64	0,56	0,46	0,33	-	99	93	88	82	76	68	60	51	-			
	7	1080	1005	927	840	740	630	490	300	-	0,86	0,80	0,74	0,67	0,59	0,50	0,39	0,24	-	88	83	78	72	66	60	52	42	-			
	6,5	1040	960	880	785	685	560	400	-	-	0,83	0,77	0,70	0,63	0,55	0,45	0,32	-	-	78	73	69	64	58	52	44	-	-			
	6	1000	920	835	735	625	485	285	-	-	0,80	0,74	0,67	0,59	0,50	0,39	0,23	-	-	71	67	62	57	51	44	35	-	-			
	5,5	960	880	785	685	560	400	-	-	-	0,77	0,70	0,63	0,55	0,45	0,32	-	-	-	64	60	55	50	44	37	-	-	-			
	5	920	830	737	625	495	300	-	-	-	0,74	0,66	0,59	0,50	0,40	0,24	-	-	-	58	53	49	44	38	30	-	-	-			
	4	840	750	640	510	340	-	-	-	-	0,67	0,60	0,51	0,41	0,27	-	-	-	-	47	43	38	33	28	-	-	-	-			
3	760	655	535	370	-	-	-	-	-	0,61	0,52	0,43	0,30	-	-	-	-	-	37	33	29	24	-	-	-	-	-				
2	680	560	400	160	-	-	-	-	-	0,54	0,45	0,32	0,13	-	-	-	-	-	29	25	21	16	-	-	-	-	-				
1	610	475	280	-	-	-	-	-	-	0,49	0,38	0,22	-	-	-	-	-	-	23	19	16	-	-	-	-	-	-				
CRS 3	10	1450	1395	1350	1310	1260	1205	1145	1075	990	1,00	0,96	0,93	0,90	0,87	0,83	0,79	0,74	0,68	136	136	136	136	136	136	134	130	124			
	9,5	1445	1390	1345	1295	1245	1185	1115	1030	935	1,00	0,96	0,93	0,89	0,86	0,82	0,77	0,71	0,64	136	136	136	136	134	131	126	121	114			
	9	1440	1385	1340	1280	1225	1155	1075	975	850	0,99	0,96	0,92	0,88	0,84	0,80	0,74	0,67	0,59	134	134	134	131	128	123	118	111	101			
	8,5	1435	1380	1335	1270	1195	1110	1015	900	750	0,99	0,95	0,92	0,88	0,82	0,77	0,70	0,62	0,52	132	132	130	126	121	115	108	99	88			
	8	1430	1370	1305	1230	1145	1050	940	800	630	0,99	0,94	0,90	0,85	0,79	0,72	0,65	0,55	0,43	129	125	121	116	110	103	95	86	74			
	7,5	1425	1345	1265	1180	1085	970	845	690	500	0,98	0,93	0,87	0,81	0,75	0,67	0,58	0,48	0,34	122	116	111	105	98	91	82	73	62			
	7	1360	1290	1210	1120	1015	895	760	590	-	0,94	0,89	0,83	0,77	0,70	0,62	0,52	0,41	-	111	106	101	95	88	81	72	62	-			
	6,5	1320	1240	1160	1060	955	825	660	460	-	0,91	0,86	0,80	0,73	0,66	0,57	0,46	0,32	-	102	97	92	86	80	72	62	51	-			
	6	1270	1190	1100	995	880	735	570	-	-	0,88	0,82	0,76	0,69	0,61	0,51	0,39	-	-	93	88	83	77	70	62	54	-	-			
	5,5	1220	1140	1040	930	800	645	450	-	-	0,84	0,79	0,72	0,64	0,55	0,44	0,31	-	-	84	80	75	69	62	54	45	-	-			
	5	1180	1080	980	865	725	545	-	-	-	0,81	0,74	0,68	0,60	0,50	0,38	-	-	-	76	71	66	61	54	46	-	-	-			
	4	1080	982	870	730	560	350	-	-	-	0,74	0,68	0,60	0,50	0,39	0,24	-	-	-	62	58	53	47	41	33	-	-	-			
3	985	875	745	570	350	-	-	-	-	0,68	0,60	0,51	0,39	0,24	-	-	-	-	49	45	40	35	29	-	-	-	-				
2	890	760	595	-	-	-	-	-	-	0,61	0,52	0,41	-	-	-	-	-	-	39	35	31	-	-	-	-	-	-				
1	770	600	405	-	-	-	-	-	-	0,53	0,41	0,28	-	-	-	-	-	-	30	26	21	-	-	-	-	-	-				

LEGEND

- Qv = Air flow
- Qv % = Correction factors for Air flow
- W = Watts absorbed by the motor
- Ap = Available pressure
- Vdc = Inverter Power

Water pressure drop

3 row coil

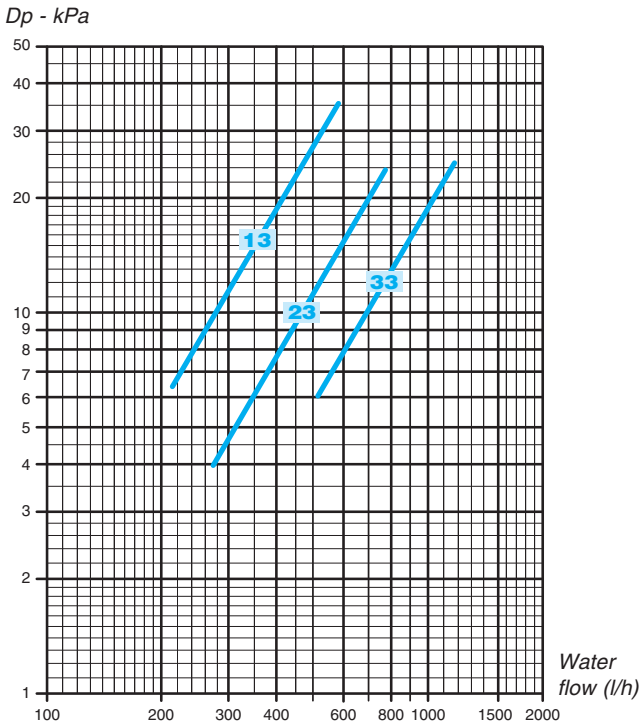

4 row coil

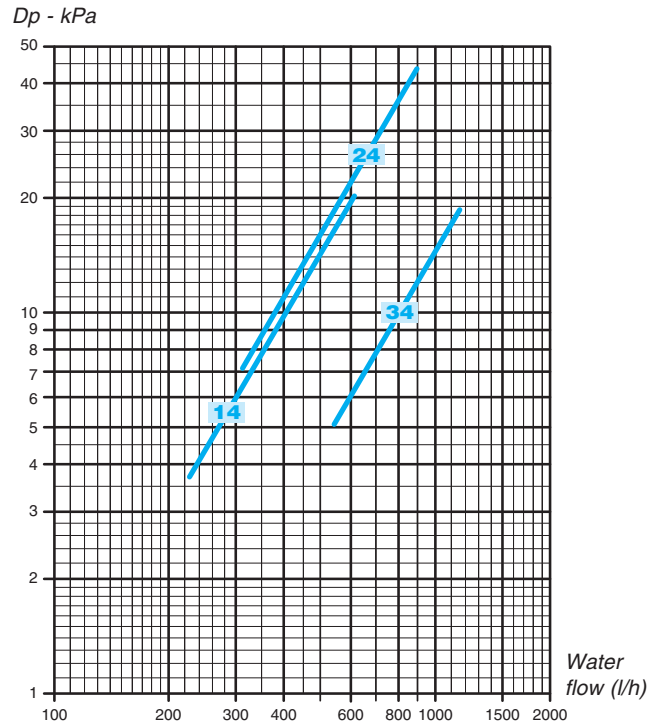

The water pressure drop figures refer to a mean water temperature of **10°C**; for different temperatures, multiply the pressure drop figures by the correction factors **K**.

°C	20	30	40	50	60	70	80
K	0,94	0,90	0,86	0,82	0,78	0,74	0,70

1 row additional coil

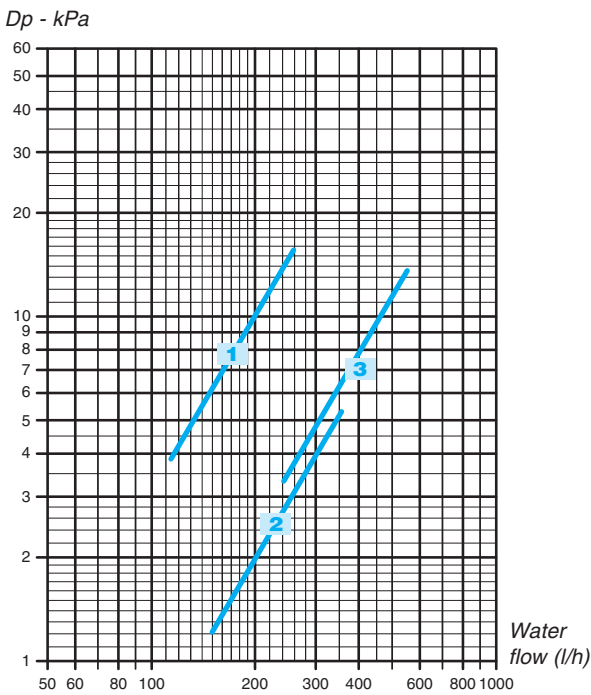

2 row additional coil

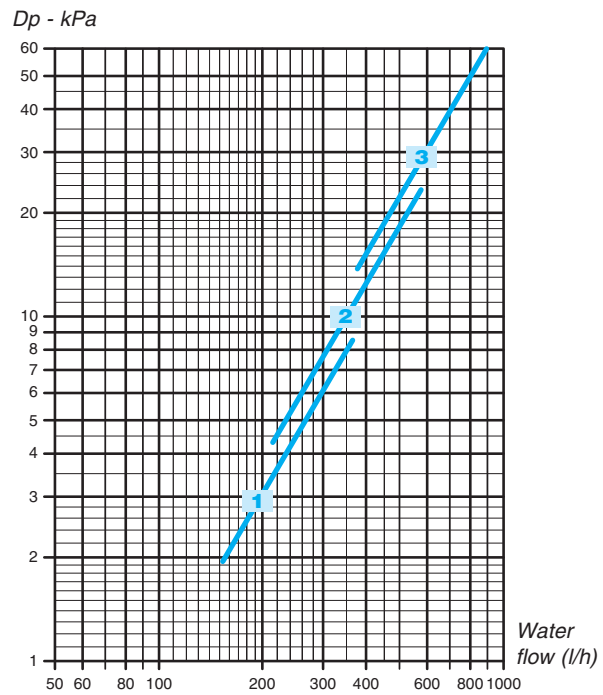

The water pressure drop figures refer to a mean water temperature of **65°C**; for different temperatures, multiply the pressure drop figures by the correction factors **K**.

°C	40	50	60	70	80
K	1,14	1,08	1,02	0,96	0,90

ACCESSORIES AND CONTROLS FOR:

CRC-ECM version with centrifugal fan

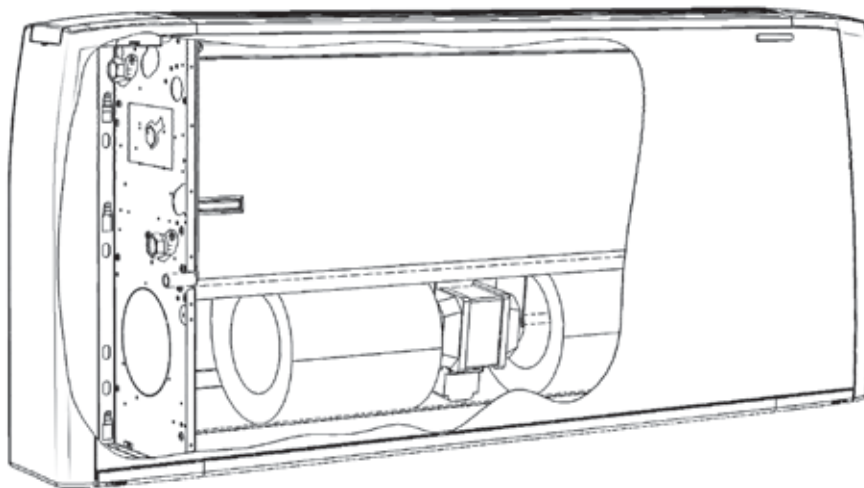

CRT-ECM version with tangential fan

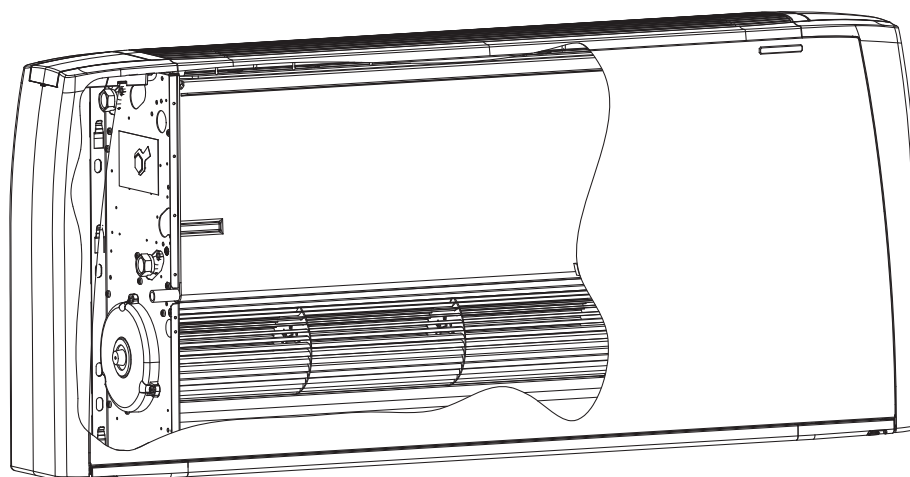

CRS-ECM version with high pressure centrifugal fan

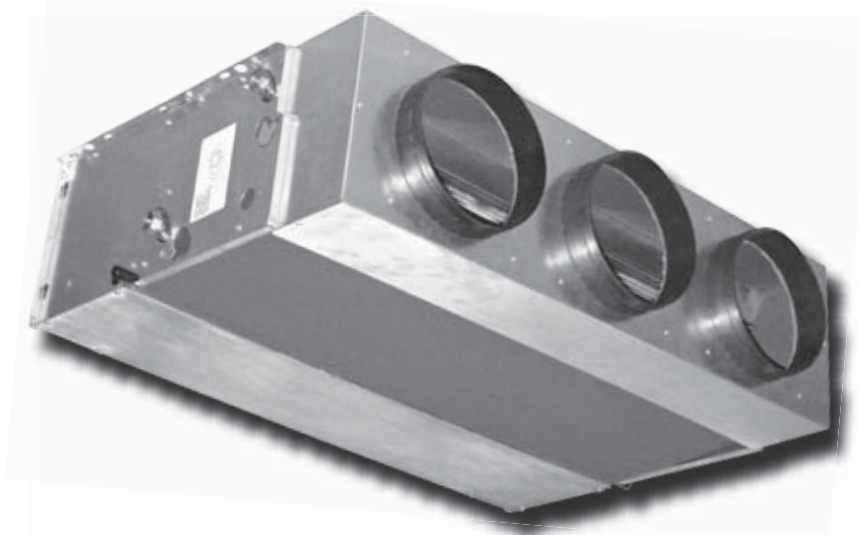

VBP
main coil 3 way valve

Control valve kit:
 3 way valve, ON-OFF,
 with electric motor and mounting kit
 with micrometric lockshield valve.

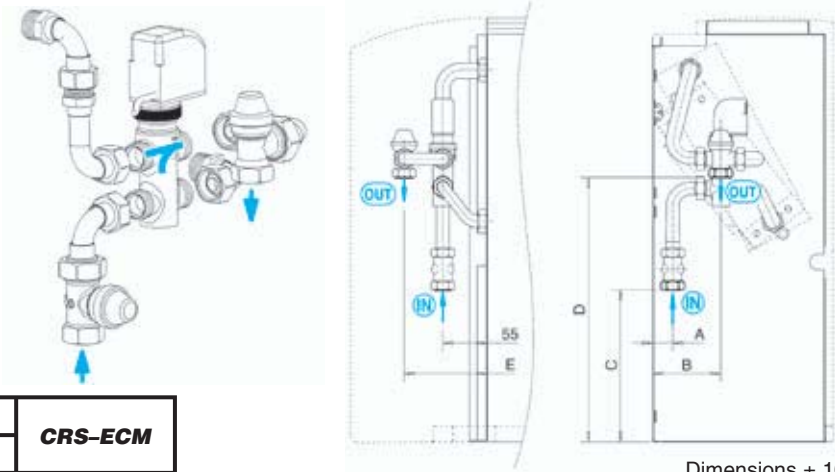

VERSION	CRC-ECM / CRT-ECM	CRS-ECM
MODEL	MV - MO - MVB - IV - IO	

Dimensions ± 10 mm

Mod.		Dimensions (mm)					Valve			Micrometric lockshield valve			Code	
CRC/CRT	CRS	A	B	C	D	E	DN	(Ø)	Kvs	DN	(Ø)	Kvs	FITTED	NOT FITTED
1 ÷ 5	1	25	85	190	290	105	15	1/2"	1,6	15	1/2" F	2	9066561H	9066560H
6 - 7	2	25	85	190	290	105	20	3/4"	2,5	15	1/2" F	2	9060471H	9060474H
9	3	50	120	185	290	105	20	3/4"	2,5	15	1/2" F	2	9060471H	9060474H

VBA
additional coil 3 way valve

Control valve kit:
 3 way valve, ON-OFF,
 with electric motor and mounting kit
 with micrometric lockshield valve.

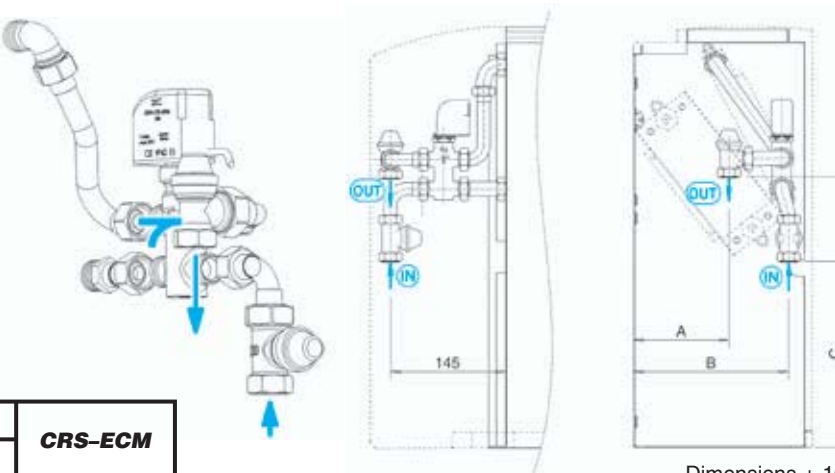

VERSION	CRC-ECM / CRT-ECM	CRS-ECM
MODEL	MV - MO - MVB - IV - IO	

Dimensions ± 10 mm

Mod.		Dimensions (mm)				Valve			Micrometric lockshield valve			Code	
CRC/CRT	CRS	A	B	C	D	DN	(Ø)	Kvs	DN	(Ø)	Kvs	FITTED	NOT FITTED
1 ÷ 7	1 - 2	120	195	240	340	15	1/2"	1,6	15	1/2" F	2	9060472H	9060475H
9	3	135	200	235	330	15	1/2"	1,6	15	1/2" F	2	9060472H	9060475H

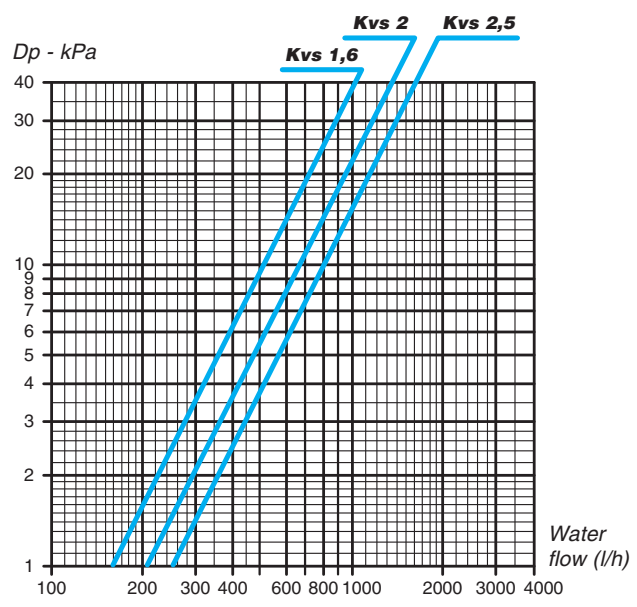

VS
simplified kit for 3 way valve
(concealed model only)

3 way valve, (ON-OFF)
with electric motor and mounting kit.
Valve with flat connection
without micrometric lockshield valve.

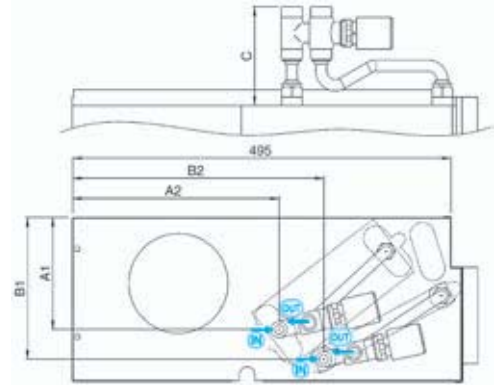
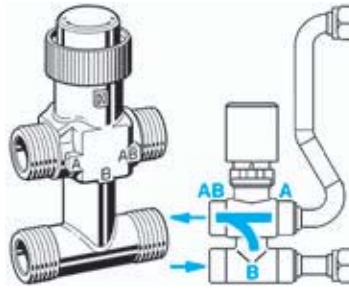

VERSION	CRC-ECM / CRT-ECM	CRS-ECM
MODEL	IV - IO	

		Dimensions (mm)					MAIN				ADDITIONAL					
MOD.	CRS	MAIN		ADDITIONAL		C	Valve			Code		Valve			Code	
		A1	A2	B1	B2		DN	(Ø)	Kvs	FITTED	NOT FITTED	DN	(Ø)	Kvs	FITTED	NOT FITTED
1 ÷ 5	1	152	270	185	330	116	15	1/2"	1,6	9066571H	9066570H	15	1/2"	1,6	9060483H	9060480H
6 - 7	2	152	268	185	330	124	20	3/4"	2,5	9060484H	9060481H					
9	3	177	270	210	327	124	20	3/4"	2,5	9060484H	9060481H					

V2
2 way valve
for main and additional coil

Control valve kit:
2 way valve, ON-OFF,
with electric motor and mounting kit.

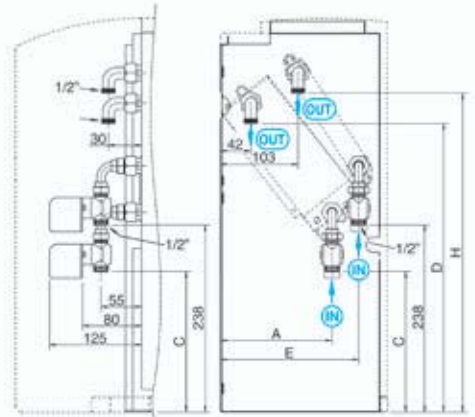
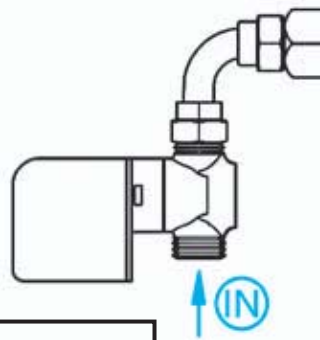

VERSION	CRC-ECM / CRT-ECM	CRS-ECM
MODEL	MV - MO - MVB - IV - IO	

		Dimensions (mm)					MAIN				ADDITIONAL					
MOD.	CRS	MAIN		ADDITIONAL		H	Valve			Code		Valve			Code	
		A	C	D	E		DN	(Ø)	Kvs	FITTED	NOT FITTED	DN	(Ø)	Kvs	FITTED	NOT FITTED
1 ÷ 5	1	149	180	386	186	456	15	1/2"	1,7	9060476H	9060478H	15	1/2"	1,7	9060476H	9060478H
6 - 7	2	150	181	438	186	456	20	3/4"	2,8	9060477H	9060479H					
9	3	176	175	422	210	440	20	3/4"	2,8	9060477H	9060479H					

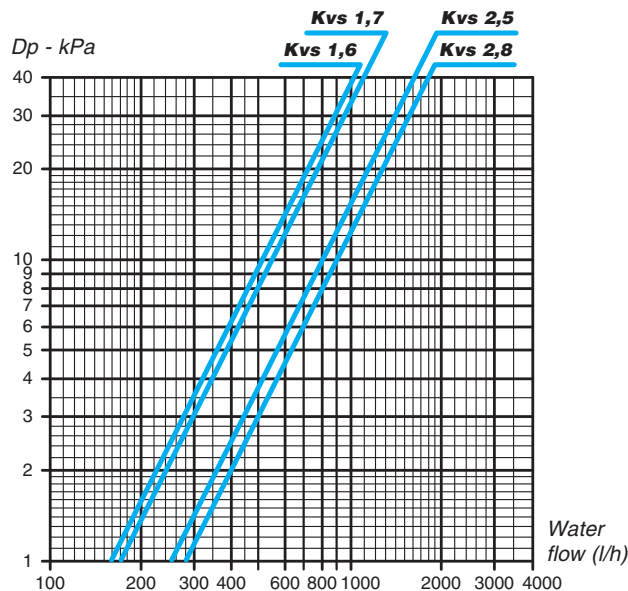

BEL electric heater

(not available with Crystall)

1 PHASE 230V

Electric heater with integral: safety thermostat and relay control.

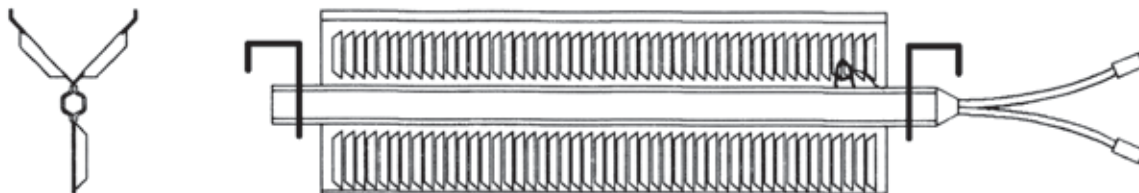

VERSION	CRC-ECM / CRT-ECM
MODEL	MV - MO - MVB - IV - IO

VERSION	CRC-ECM / CRT-ECM	CRS-ECM
MODEL	IV - IO	

SIZE		WATT	CODE
CRC	CRT		
-	1	650	9066491
2	2	1000	9066492
		600	9066482
		400	9066472
4	3	1500	9066493
		900	9066483
		600	9066473
6	5	2000	9066495
		1250	9066485
		750	9066475
7 - 9	7	2500	9066497
		1500	9066487
		1000	9066477

SIZE			WATT	CODE
CRC	CRT	CRS		
-	1	-	650	9066611
2	2	-	1000	9066612
			600	9066602
			400	9066592
4	3	1	1500	9066613
			900	9066603
			600	9066593
6	5	2	2000	9066615
			1250	9066605
			750	9066595
7 - 9	7	3	2500	9066617
			1500	9066607
			1000	9066597

NOTE: for ECM range the controls can control the electric heater only if there is no hot water supply.

BSV extension condensate collection tray to cover valve assembly

(for vertical units)

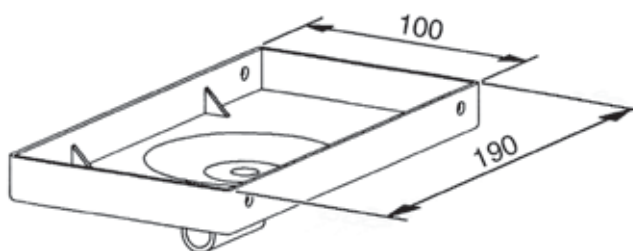

VERSION	CRC-ECM / CRT-ECM
MODEL	MV - MVB - IV (vertical)
CODE	6060400

VERSION	CRS-ECM
CODE	6060400

BSO extension condensate collection tray to cover valve assembly
(for horizontal units)

VERSION	CRC-ECM / CRT-ECM	
MODEL	MO - IO (horizontal)	
CONNECTION SIDE	LEFT	RIGHT
TYPE	BSO-SX	BSO-DX
CODE	6060402	6060403

VERSION	CRS-ECM	
CONNECTION SIDE	LEFT	RIGHT
TYPE	BSO-SX	BSO-DX
CODE	6060402	6060403

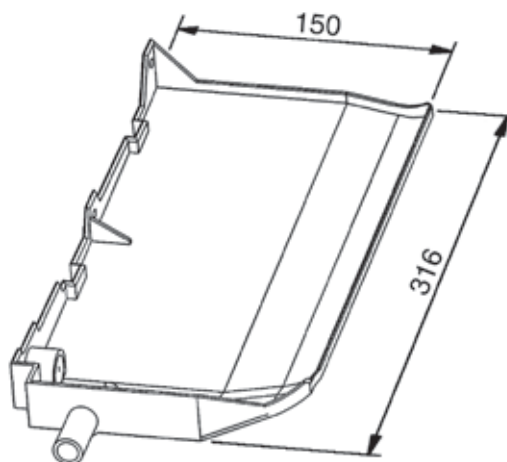

DRPV-C fitted condensate pump
(for vertical units)

VERSION	CRC-ECM / CRT-ECM
MODEL	MV - MVB - IV (vertical)
CODE	9060107

VERSION	CRS-ECM
CODE	9060107

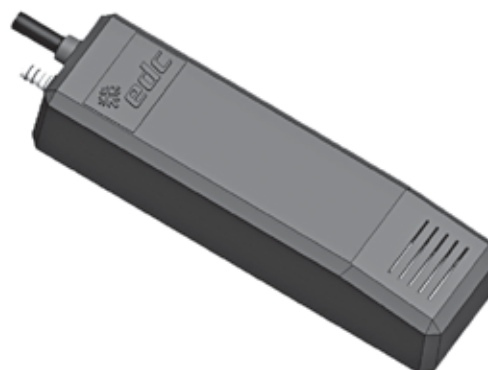

DRPO-C fitted condensate pump
(for horizontal units)

VERSION	CRC-ECM / CRT-ECM
MODEL	MO - IO (horizontal)
CODE	9066295

VERSION	CRS-ECM
CODE	9066295



SCR plastic condensate drain pipe with fast connection
(allows correct condensate drain)

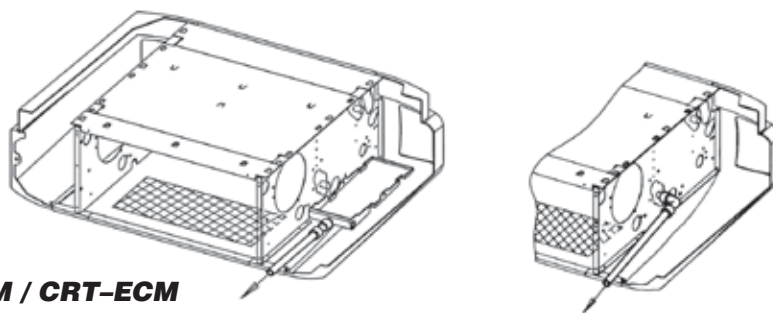

CRC-ECM / CRT-ECM

CRS-ECM

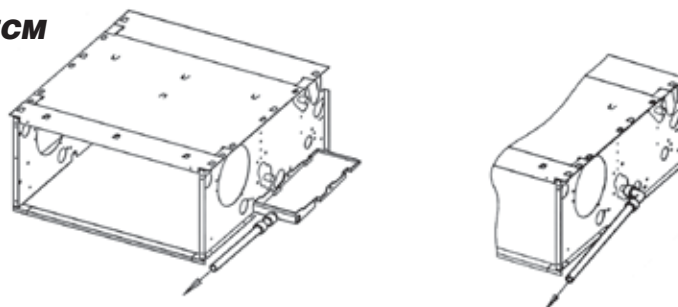

VERSION	CRC-ECM / CRT-ECM	CRS-ECM
MODEL	MO - IO	
CODE	6060420	

PAP feet

VERSION	CRC-ECM / CRT-ECM
MODEL	MV

SIZE	L	CODIE
1	330	9066351
2	430	9066351
3 - 4	645	9066351
5 - 6	860	9066351
7	1119	9066351
9	1119	9066358

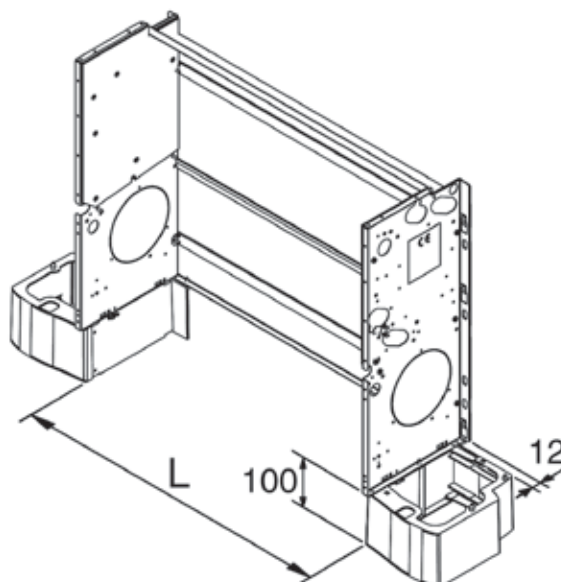

GAP

Aluminium low intake grid
(to be installed with PAP feet)

VERSION	CRC-ECM / CRT-ECM
MODEL	MV

SIZE	CODE
1	9066541
2	9066542
3 - 4	9066543
5 - 6	9066545
7 - 9	9066547

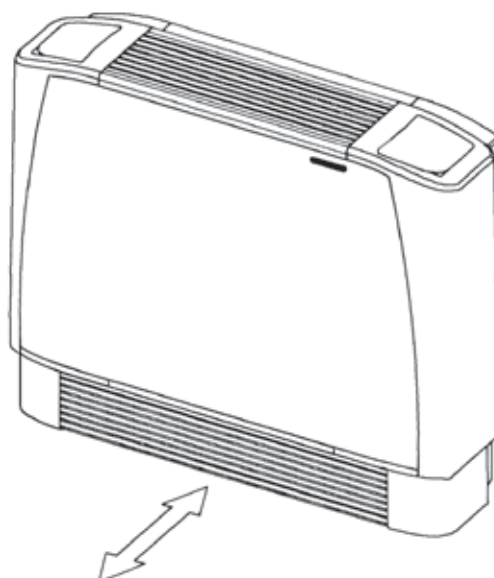

KAF frontal intake kit

Bottom closing panel and filter sliding guides.

VERSION	CRC-ECM / CRT-ECM
MODEL	IV - IO

SIZE	CODE
1	9066501
2	9066502
3 - 4	9066503
5 - 6	9066505
7	9066507
9	9066508

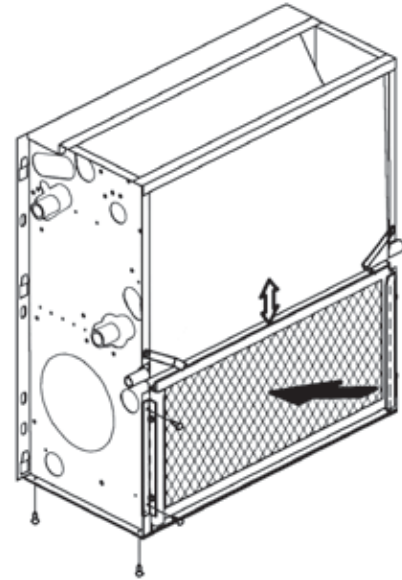

PCV rear closing panel

(for vertical units)

VERSION	CRC-ECM / CRT-ECM
MODEL	MV - MVB

SIZE	CODE
1	9066511
2	9066512
3 - 4	9066513
5 - 6	9066515
7 - 9	9066517

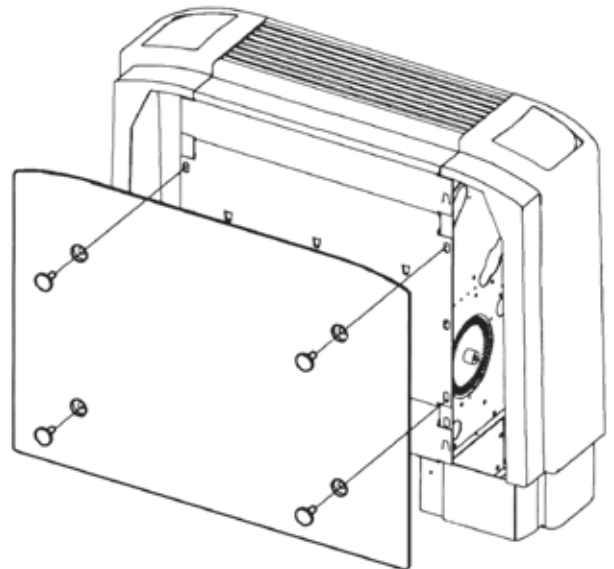

PCO bottom closing panel

(for horizontal units)

VERSION	CRC-ECM / CRT-ECM
MODEL	MO - MVB

SIZE	CODE
1	9066521
2	9066522
3 - 4	9066523
5 - 6	9066525
7	9066527
9	9066528

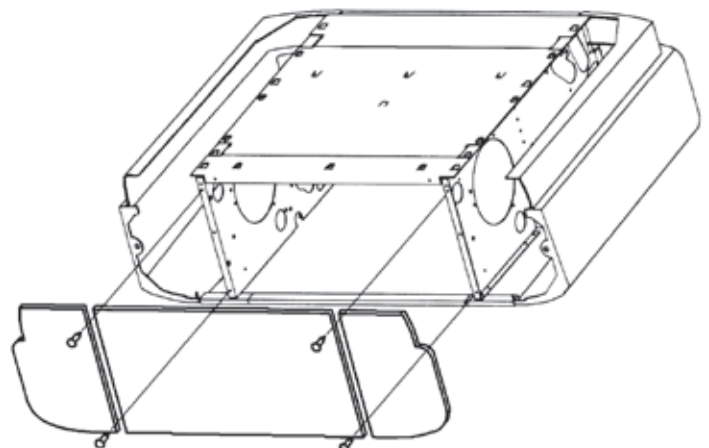

SAEM fresh air mixing damper

(factory mounted with feet and intake grid included, MV only)

(can not be motorized)

VERSION	CRC-ECM / CRT-ECM
MODEL	MV

SIZE	A	B	L	CODE
1	186	78	354	9066621
2	186	78	454	9066622
3 - 4	186	78	669	9066623
5 - 6	186	78	884	9066625
7	186	78	1099	9066627
9	216	108	1099	9066628

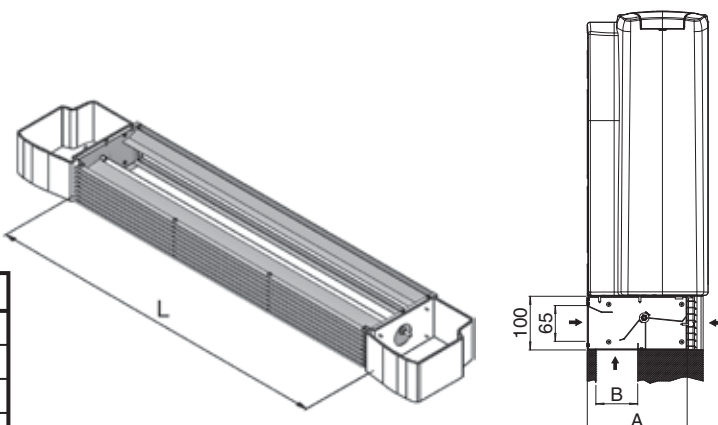

SAE fresh air mixing damper

(not mounted, IV - IO only)

(can not be motorized)

VERSION	CRC-ECM / CRT-ECM
MODEL	IV - IO

SIZE	A	B	L	CODE
1	186	78	354	9066531
2	186	78	454	9066532
3 - 4	186	78	669	9066533
5 - 6	186	78	884	9066535
7	186	78	1099	9066537
9	216	108	1099	9066538

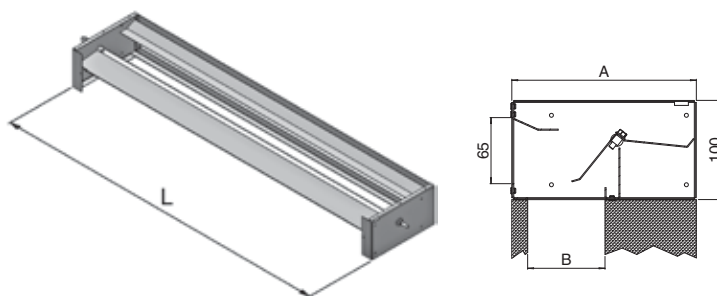

FRD straight inlet flange

Can be used together with GRAG air inlet grid.

Made of galvanized steel.

VERSION	CRC-ECM / CRT-ECM	CRS-ECM
MODEL	IV - IO	

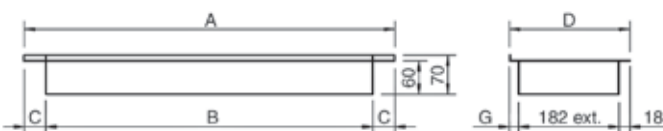

SIZE		TYPE	A	B	C	D	G	CODE
CRC/CRT	CRS							
1	-	FRD - 1	354	290	32	216	16	9066451
2	-	FRD - 2	454	390	32	216	16	9060720
3 - 4	1	FRD - 3/4	669	590	39,5	216	16	9060721
5 - 6	-	FRD - 5/6	884	790	47	216	16	9060722
-	2	FRD - 4S	884	790	47	246	46	9038002
7	-	FRD - 7	1099	990	54,5	216	16	9060723
9	3	FRD - 8/9	1099	990	54,5	246	46	9060724

FR 90 90° inlet flange

Can be used together with GRAP air inlet grid.
Made of galvanized steel.

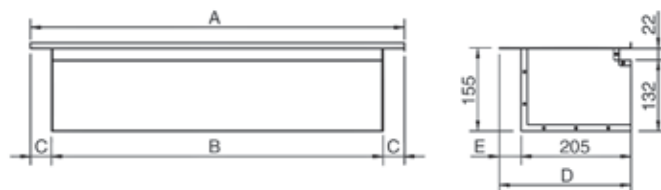

VERSION	CRC-ECM	CRS-ECM
MODEL	IV - IO	

SIZE		TYPE	A	B	C	D	E	CODE
CRC	CRS							
2	-	FR90 - 2	454	390	32	216	11	9060710
4	1	FR90 - 3/4	669	590	39,5	216	11	9060711
6	-	FR90 - 5/6	884	790	47	216	11	9060712
-	2	FR90 - 4S	884	790	47	246	41	9038001
7	-	FR90 - 7	1099	990	54,5	216	11	9060713
9	3	FR90 - 8/9	1099	990	54,5	246	41	9060714

GRAP air inlet grid

To be used with FR 90 90° inlet flange.
Made of anodized aluminium.

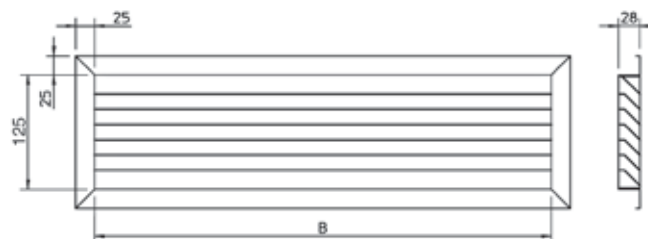

VERSION	CRC-ECM	CRS-ECM
MODEL	IV - IO	

SIZE		TYPE	DESCRIPTION	B	CODE
CRC	CRS				
2	-	GRAP - 2	Grid 400x150	375	9060760
4	1	GRAP - 3/4	Grid 600x150	575	9060761
6	2	GRAP - 5/6	Grid 800x150	775	9060762
7 - 9	3	GRAP - 7/9	Grid 1000x150	975	9060763

GRAG air inlet grid

To be used with FRD straight inlet flange.
Made of anodized aluminium.

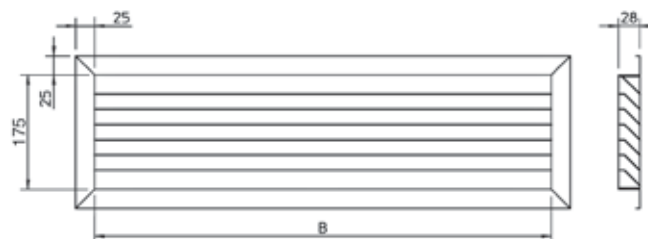

VERSION	CRC-ECM / CRT-ECM	CRS-ECM
MODEL	IV - IO	

SIZE		TYPE	DESCRIPTION	B	CODE
CRC/CRT	CRS				
1	-	GRAG - 1	Grid 300x200	275	9066431
2	-	GRAG - 2	Grid 400x200	375	9060764
3 - 4	1	GRAG - 3/4	Grid 600x200	575	9060765
5 - 6	2	GRAG - 5/6	Grid 800x200	775	9060766
7 - 9	3	GRAG - 7/9	Grid 1000x200	975	9060767

FRC fresh air connection
(not mounted)

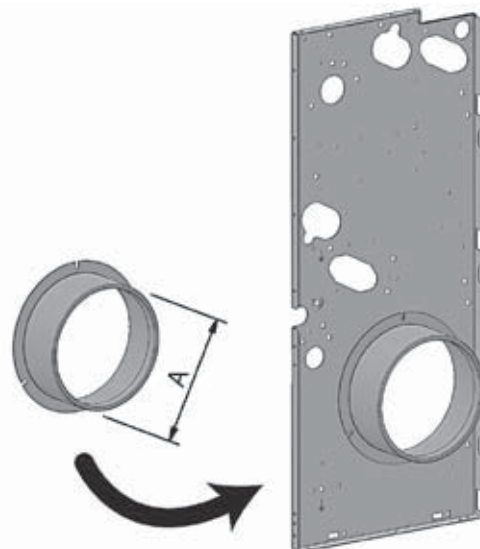

VERSION	CRC-ECM
MODEL	IV - IO

SIZE	TYPE	A	CODE
1 ÷ 7	FRC 100	98	6064191
1 ÷ 7	FRC 120	122	6064192

FMD straight outlet flange

Made of galvanized steel.



VERSION	CRC-ECM / CRT-ECM	CRS-ECM
MODEL	IV - IO	

SIZE		TYPE	A	B	C	D	CODE
CRC/CRT	CRS						
1	-	FMD - 1	352	290	31	152	9066371
2	-	FMD - 2	452	390	31	152	9066372
3 - 4	1	FMD - 3/4	667	590	38,5	152	9066373
5 - 6	-	FMD - 5/6	882	790	46	152	9066375
-	2	FMD - 4S	882	790	46	179	9069232
7	-	FMD - 7	1097	990	53,5	152	9066377
9	3	FMD - 8/9	1097	990	53,5	179	9066378

FM 90 90° outlet flange

Made of galvanized steel
insulated with polyethylene lining.

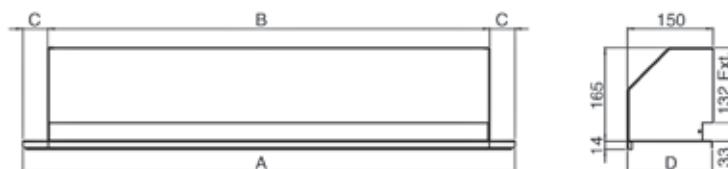

VERSION	CRC-ECM	CRS-ECM
MODEL	IV - IO	

SIZE		TYPE	A	B	C	D	CODE
CRC	CRS						
2	-	FM90 - 2	452	390	31	152	9066382
4	1	FM90 - 3/4	667	590	38,5	152	9066383
6	-	FM90 - 5/6	882	790	46	152	9066385
-	2	FM90 - 4S	882	790	46	179	9060242
7	-	FM90 - 7	1097	990	53,5	152	9066387
9	3	FM90 - 8/9	1097	990	53,5	179	9066388

BMA air outlet grid

Double louvre grid to be fitted to the duct, to the FMD straight outlet flange or to the FM 90° 90° outlet flange. Made of anodized aluminium.

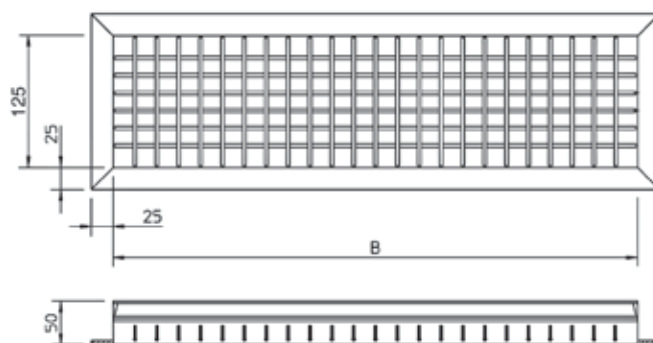

VERSION	CRC-ECM / CRT-ECM	CRS-ECM
MODEL	IV - IO	

SIZE		TYPE	B	CODE
CRC/CRT	CRS			
1	-	BMA - 1	275	9066411
2	-	BMA - 2	375	9060750
3 - 4	1	BMA - 3/4	575	9060751
5 - 6	2	BMA - 5/6	775	9060752
7 - 9	3	BMA - 7/9	975	9060753

PRC air inlet spigot plenum

Made of galvanized steel insulated with polyethylene lining.

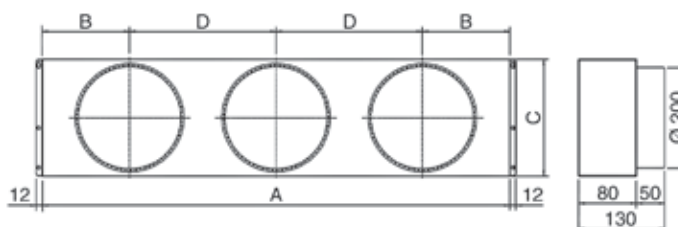

VERSION	CRC-ECM	CRS-ECM
MODEL	IV - IO	

SIZE		TYPE	A	B	C	D	SPIGOTS	CODE
CRC	CRS							
2	-	PRC - 2	430	107	218	216	N° 2	9066462
4	1	PRC - 3/4	645	166	218	313	N° 2	9066463
6	-	PRC - 5/6	860	160	218	270	N° 3	9066465
-	2	PRC - 4S	860	160	248	270	N° 3	9038050
7	-	PRC - 7	1075	190	218	347,5	N° 3	9066467
9	3	PRC - 8/9	1075	190	248	347,5	N° 3	9066468

All the plenums are supplied with spigots for the connection of flexible ducts.

PMC spigot diffuser

Made of galvanized steel insulated with polyethylene lining.

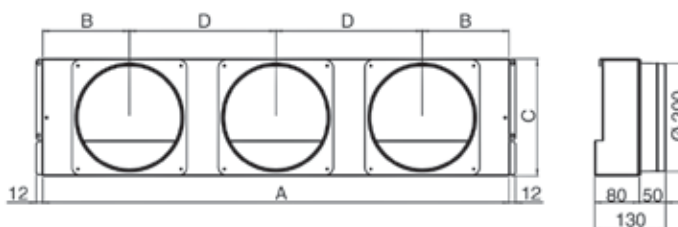

VERSION	CRC-ECM	CRS-ECM
MODEL	IV - IO	

SIZE		TYPE	A	B	C	D	SPIGOTS	CODE
CRC	CRS							
2	-	PMC - 2	430	107	218	216	N° 2	9066362
4	1	PMC - 3/4	645	166	218	313	N° 2	9066363
6	-	PMC - 5/6	860	160	218	270	N° 3	9066365
-	2	PMC - 4S	860	160	248	270	N° 3	9069222
7	-	PMC - 7	1075	190	218	347,5	N° 3	9066367
9	3	PMC - 8/9	1075	190	248	347,5	N° 3	9066368

All the plenums are supplied with spigots for the connection of flexible ducts.

GRAFP air inlet grid with filter

To be fitted to the FR 90 90° inlet flange.
Made of anodized aluminium.

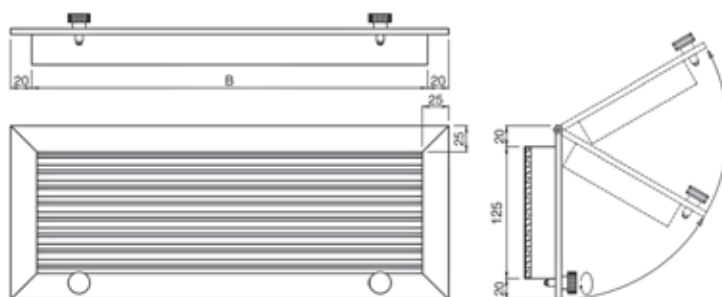

VERSION	CRC-ECM
MODEL	IV - IO

SIZE	TYPE	B	CODE
2	GRAFP - 2	375	9060770
4	GRAFP - 3/4	575	9060771
6	GRAFP - 5/6	775	9060772
7 - 9	GRAFP - 7/9	975	9060773

GRAFG air inlet grid with filter

To be fitted to the FRD straight inlet flange.
Made of anodized aluminium.

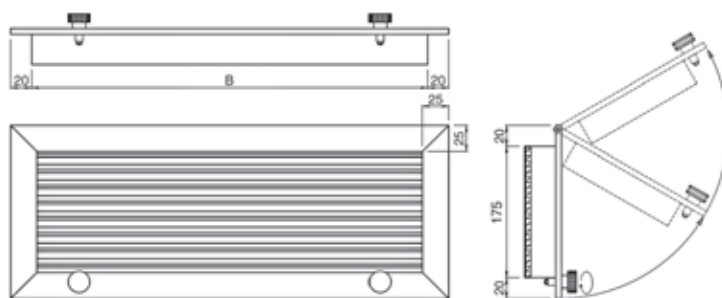

VERSION	CRC-ECM
MODEL	IV - IO

SIZE	TYPE	B	CODE
2	GRAFG - 2	375	9060774
4	GRAFG - 3/4	575	9060775
6	GRAFG - 5/6	775	9060776
7 - 9	GRAFG - 7/9	975	9060777



Crystall

Introduction

The **CRYSTALL SABIANA** electrostatic filter matches the need for better air conditioning with the concepts of space and design.

With this filter the various stages of air treatment are combined in one appliance.

Thanks to this new patented filter (efficiency compliant with new Standard UNI 11254), air pollutants such as cigarette smoke, dust (PM10, PM2.5), pollen and most biological organisms are eliminated.

In addition, as fresh air is not being introduced to obtain the best climatic conditions, there are consequential energy savings.

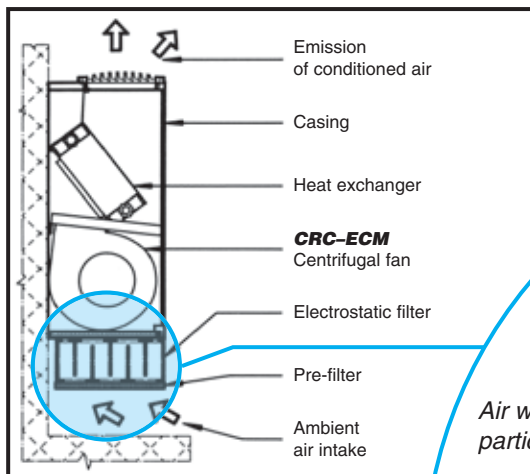

Operating principle of the **CRYSTALL SABIANA** electronic filter

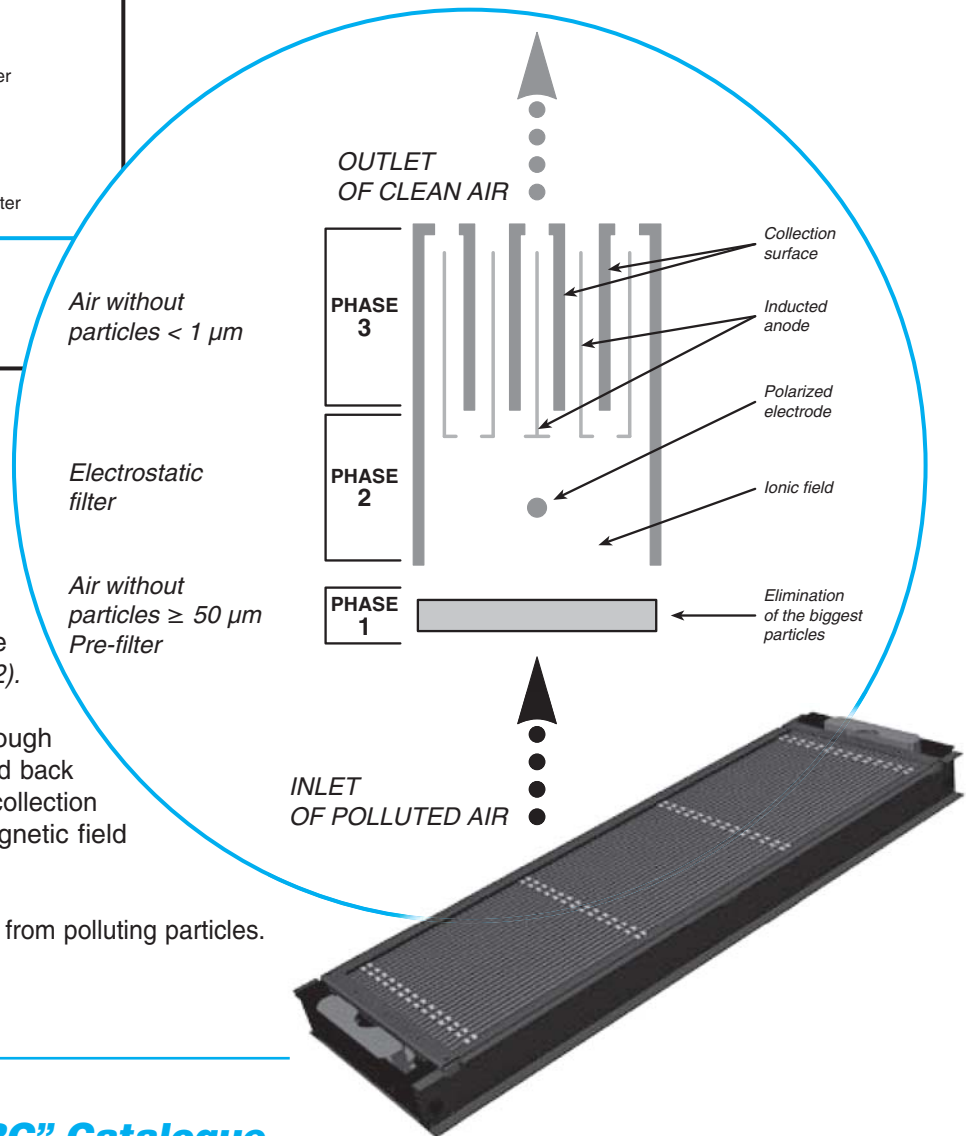

When polluted air goes through the mechanical pre-filter (*Phase 1*) the particles $\geq 50 \mu\text{m}$ are eliminated (powder, insects, etc.).

Then the smallest particles ($50 \div 0.01 \mu\text{m}$) are exposed to an intensive ionic field and are polarized (*Phase 2*).

The charged particles passing through the second filter section, are pushed back by the anode and attracted to the collection surfaces by a strong, induced magnetic field (*Phase 3*).

The air which leaves the unit is free from polluting particles.

For more details see the "Carisma CRC" Catalogue

CRC-ECM / CRT-ECM / CRS-ECM configuration

For this fan coil configuration, the 1-10 Vdc signal, which controls the inverter, must be supplied by a controller with the following signal specifications:

- Impedance < 100 Ω;
- Maximum speed 10Vdc;
- Fan OFF with V < 0,9Vdc.

CRC-ECM / CRT-ECM / CRS-ECM electric wiring diagram

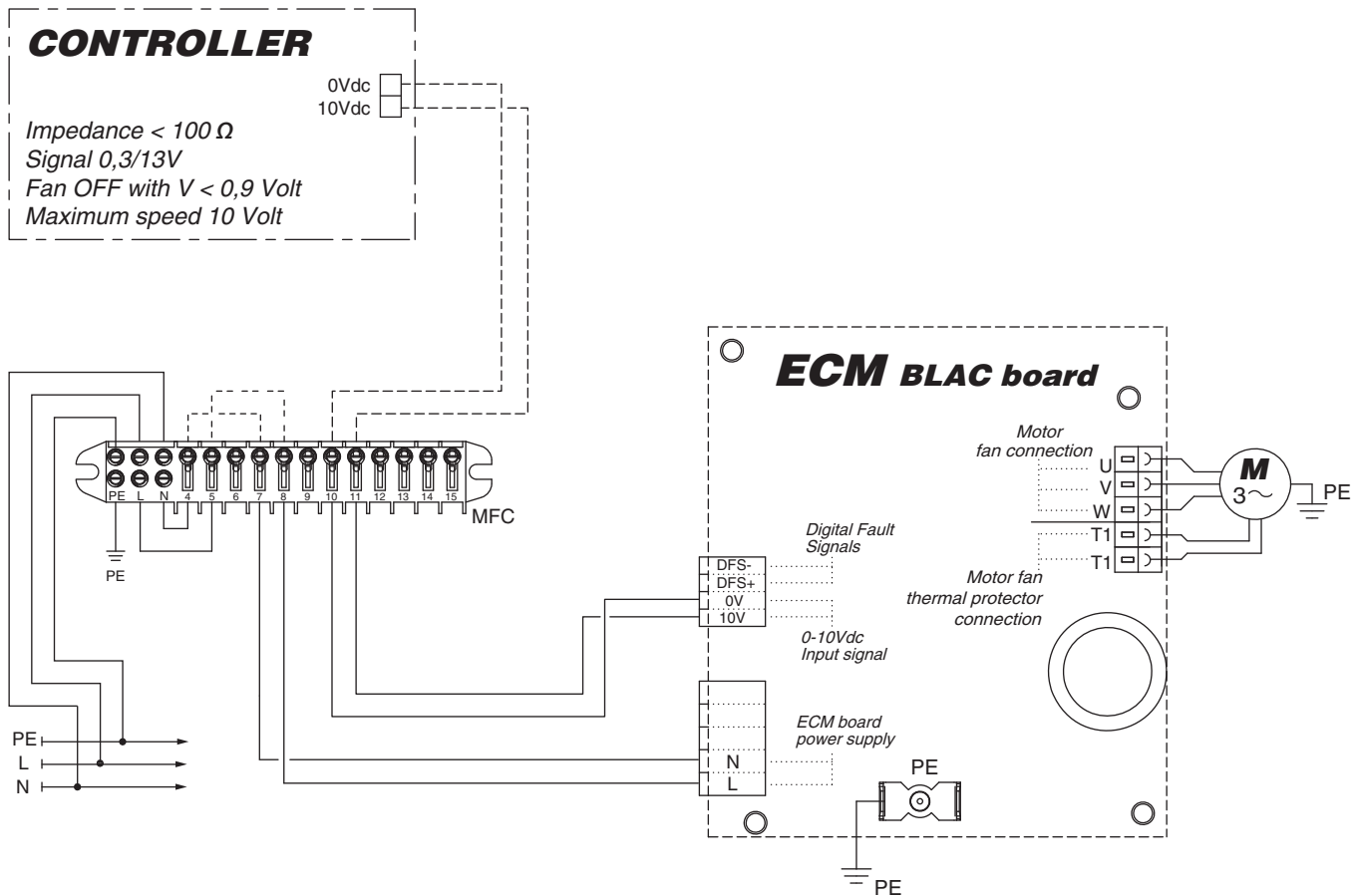

LEGEND:

BLAC = Inverter circuit board **M** = Electronic motor **CONTROLLER** = Controller

Electronic control to be fitted – **CRC-ECM / CRT-ECM** version

IDENTIFICATION	CODE
CB-T-ECM	9066320



- ON-OFF switch.
- Manual 3 speed switch or automatic continuous speed control.
- Manual Summer/Winter switch.
- Continuous speed control based on the difference between ambient temperature and Set temperature (speed switch in Auto position).
- Electronic room thermostat for fan or valve control (ON-OFF).
- Simultaneous thermostatic control of the valves and fan.
- It allows to control the temperature cut-out (NTC).

Control power absorption: 1,5 VA

Electronic control to be fitted – **CRC-ECM** version with **Crystall** filter

IDENTIFICATION	CODE
CB-T-ECM-IAQ	9066308



- ON-OFF switch.
- Manual 3 speed switch or automatic continuous speed control.
- Manual Summer/Winter switch.
- Continuous speed control based on the difference between ambient temperature and Set temperature (speed switch in Auto position).
- Electronic filter ON-OFF switch (or electric heater).
- Electronic room thermostat with automatic speed selection. When the setpoint is reached the fan and the filter go on OFF.
- Electronic room thermostat for fan or valve control (ON-OFF).
- Simultaneous thermostatic control of the valves and fan.
- It allows to control low temperature cut-out thermostat (NTC).
- It allows to control summer/winter cycle with a centralized and remote switch or with an automatic change-over fitted on the water pipe (for 2-tube installations only).

Control power absorption: 1,5 VA

Wall electronic controls – **CRC-ECM / CRT-ECM / CRS-ECM** version

IDENTIFICATION	CODE
CR-T-ECM	9066342



Dimensions: 133x93x37 mm

The control must always be connected with UPM-ECM power unit (fitted on the unit) or with UPS-ECM power unit (not fitted on the unit).

- It allows to control up to 16 units (one power unit for each unit).
- ON-OFF switch.
- Manual 3 speed switch or automatic continuous speed control.
- Manual Summer/Winter switch.
- Continuous speed control based on the difference between ambient temperature and Set temperature (speed switch in Auto position).
- Electronic room thermostat for fan or valve control (ON-OFF).
- Simultaneous thermostatic control of the valves and fan.
- It allows to control low temperature cut-out thermostat (NTC).
- It allows to control summer/winter cycle with a centralized and remote switch or with an automatic change-over fitted on the water pipe (for 2-tube installations only).

IDENTIFICATION	CODE
CR-DI-ECM	9066316



Dimensions: 135x88x25 mm

The control must always be connected with UPM-ECM power unit (fitted on the unit) or with UPS-ECM power unit (not fitted on the unit).

- It allows to control up to 16 units (one power unit for each unit).
- ON-OFF switch.
- Manual 3 speed switch or automatic continuous speed control.
- Manual Summer/Winter switch.
- Continuous speed control based on the difference between ambient temperature and Set temperature (speed switch in Auto position).
- Electronic room thermostat for fan or valve control (ON-OFF).
- Simultaneous thermostatic control of the valves and fan.
- It allows to control low temperature cut-out thermostat (NTC).
- It allows to control summer/winter cycle with a centralized and remote switch or with an automatic change-over fitted on the water pipe (for 2-tube installations only).
- Time setting.
- Weekly ON/OFF program.

DESCRIPTION	IDENTIFICATION	CODE
Power unit for CR-T-ECM and CR-DI-ECM remote controls (fitted on the unit)	UPM-ECM	9066341
Power unit for CR-T-ECM and CR-DI-ECM remote controls (not fitted on the unit)	UPS-ECM	9066340



Power unit to be installed on the fan coil (fan coil interface).
It controls the fan and the valves of the fan coil.
The power unit is connected to the electric supply.
The power unit receives the information required from the control.

Control power absorption: 1,5 VA

Electronic control accessories

NTC low temperature cut-out thermostat

To be fitted between the coil fins; when connecting the control, the NTC probe cable must be separated from the power supply wires.

To be used with the following controls:

CB-T-ECM, CB-T-ECM-IAQ, CR-T-ECM and **CR-DI-ECM**.

It stops the fan when the water temperature is lower than 28°C and it starts the fan when is higher than 33°C.



VERSION	CRC-ECM / CRT-ECM	CRS-ECM
MODEL	MV - MO - MVB - IV - IO	
CODE	3021090	

Change-Over CH 15-25

Automatic summer/winter switch to be installed in contact with the water circuit.

For 2-tube installations only (not to be used with 2 way valve).

To be used with the following controls:

CB-T-ECM-IAQ, CR-T-ECM and **CR-DI-ECM**.

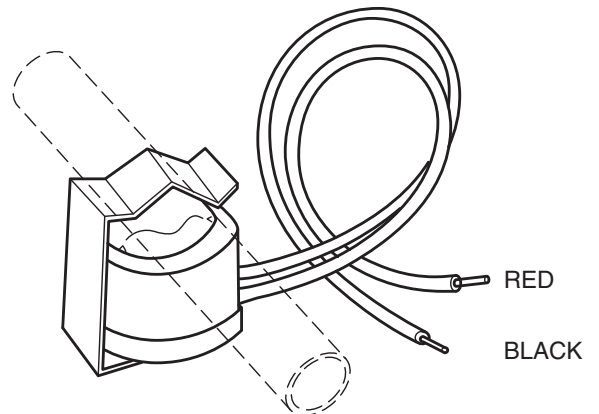

VERSION	CRC-ECM / CRT-ECM	CRS-ECM
MODEL	MV - MO - MVB - IV - IO	
CODE	9053049	

Controls and units **MB** version

All the **Carisma** units can be supplied with a wide range of controls, which allows managing one single unit or several units by using the Modbus RTU - RS 485 communication protocol. Units can be managed according to the Master/Slave logic (up to 20 units) or by supervisory components. The system consists in a **MB** board and a series of controls, such as the **T-MB** control, the **RT03** infra-red remote control, the **PSM-DI** multifunction control and the **Sabianet** supervisory program.

MB electronic board

DESCRIPTION	IDENTIFICATION	CODE
MB electronic board fitted on the unit	MB-ECM-M	9066334
MB electronic board supplied with separate packaging	MB-ECM-S	9066335

The **MB** electronic board, to be mounted on the fan coil internal unit, is set to carry out different functions and adjustment modes, in order to meet the installation requirements. These modes are selected by setting the configuration dip switches on the board.



- 2/4 pipe system.
- Fan ON/OFF thermostatic control.
- Valve ON/OFF thermostatic control and continuous ventilation.
- Valve and simultaneous ventilation ON/OFF thermostatic control.
- Fan operation control depending on the coil temperature (cut-out T3 probe fitted), which can be activated only in heating mode or heating and cooling mode.
- Automatic switch of the operating mode by means of T2 water probe (optional) applied on the 2 pipe system.
- Seasonal switch by means of remote contact.
- ON/OFF of the fan coil by means of the remote contact (window or clock contact).
- Electric heater or Crystall electronic filter control (the simultaneous control of the heater and of the Crystall filter is not possible).

By activating the cut-out T3 probe function, the fan is stopped in winter when the coil temperature is lower than 32°C and started when the temperature reaches 36°C. In summer mode, the fan stops when the temperature inside the coil exceeds 22°C and starts when it drops below 18°C.

The following connections are located on the power board:

- Receiver for infra-red remote control.
- T-MB control.
- RS 485 serial connection to manage several fan coils in Master/Slave configuration or to create a supervisory network.

Controls and units MB version

T-MB control

DESCRIPTION	IDENTIFICATION	CODE
Wall control (to be used with MB board only)	T-MB	9066331E
Control fitted on the unit, for MV / MVB models with left connections (to be used with MB board only) - CRC-ECM / CRT-ECM only	T-MB-M	9066344
Control supplied with separate packaging, for MV / MVB models with left connections (to be used with MB board only) - CRC-ECM / CRT-ECM only	T-MB-S	9066343
Control fitted on the unit, for MV / MVB models with right connections (to be used with MB board only) - CRC-ECM / CRT-ECM only	T-MB-M-DX	9066346
Control supplied with separate packaging, for MV / MVB models with right connections (to be used with MB board only) - CRC-ECM / CRT-ECM only	T-MB-S-DX	9066345

Control with display that allows controlling one or more units in Master/Slave mode. The control is equipped with internal sensor to detect the room temperature, which can be defined as a priority compared to the return air sensor on the fan coil.

The **T-MB** control features the following functions:

- Switch the appliance ON and OFF.
- Temperature set.
- Modify the set point (when used as a +/- 3° variation of the set point configured from Sabianet supervisory program).
- Set the fan speed (low, medium, high or autofan).
- Set the operation mode (fan only, cooling, heating; auto for 4 pipe systems with mode selection depending on the air temperature).
- Time setting.
- Weekly ON/OFF program.
- Display and change of the fan coil operation parameters.



Controls and units **MB version**

RT03 infra-red remote control

DESCRIPTION	IDENTIFICATION	CODE
RT03 infra-red remote control with fitted receiver, for MV / MO-MVB models (to be used with MB board only) - CRC-ECM / CRT-ECM only	RM-RT03	9066336
RT03 infra-red remote control with receiver supplied with separate packaging (to be used with MB board only)	RS-RT03	9066337
Receiver for RT03 infra-red remote control fitted on the unit, for MV / MO-MVB models (to be used with MB board only) - CRC-ECM / CRT-ECM only	RM	9066339
Receiver for RT03 infra-red remote control supplied with separate packaging (to be used with MB board only)	RS	9066338
RT03 infra-red remote control supplied with separate packaging (to be used with MB board only)	RT03	3021203

The infra-red remote control allows setting by a remote position the fan coil operation parameters.

The **RT03** infra-red remote control features the following functions:

- Switch the appliance ON and OFF.
- Temperature set.
- Set the fan speed (low, medium, high or autofan).
- Set the operation mode (fan only, cooling, heating; auto for 4 pipe systems with mode selection depending on the air temperature).
- Time setting.
- 24 hours ON/OFF program.



INSTALLATION EXAMPLE
WITH INFRA-RED REMOTE CONTROL

Controls and units **MB** version

A group of **Carisma** units with **MB** electronic board can be connected via a serial link and can consequently be managed at the same time by just one **T-MB** control or **RT03** infra-red remote control. Using the special jumper present on the **MB** board, one unit must be configured as the master, and all the others as slaves. It is clear that the remote control must be pointed at the receiver on the master unit. To avoid problems, it is recommended to install and connect the receiver only on the master unit.

With T-MB control

One control for each unit
(MAXIMUM LENGTH OF THE CONNECTION CABLE = 20 m)



One control for more units (20 units max.)
(MAXIMUM TOTAL LENGTH OF THE CONNECTION CABLE = 800 m)



With RT03 infra-red remote control

One control for each unit



One control for more units (20 units max.)
(MAXIMUM TOTAL LENGTH OF THE CONNECTION CABLE = 800 m)



T2 accessory for units with MB electronic board

IDENTIFICATION	CODE
T2	9025310



The T2 sensor can be combined with MB boards to be placed on the water supply pipe upstream 3 way valves (not to be used with 2 way valve).

The T2 sensor must be used as described below:

- Change-Over for 2-pipe system for the automatic switch of the operating mode.
If water temperature is lower than 20°C, cooling mode is set; on the other hand, if water temperature exceeds 30°C, heating mode is set.
- It can be used on units with electric heater and hot water supply. The T2 priority probe activates the electric heater or water valve, depending on the water temperature detected. If water temperature exceeds 34°C, the water valve ON-OFF control is activated; on the other hand, if water temperature is lower than 30°C, the electric heater is activated.

Controls and units **MB version**

PSM-DI multifunction control

DESCRIPTION	IDENTIFICATION	CODE
Multifunction control (to be used with MB board only)	PSM-DI	3021293

Another option available for the serial communication between the units is the possibility to connect up to 60 **Carisma** units in series and manage them with just one wall mounted **PSM-DI** controller. The wall mounted controller can be used to set the operating mode for each individual unit connected, display the operating conditions of each individual unit, and set the ON/OFF time sets for each day of the week (the program can be set for all the units and for a maximum of two groups of units).

If more than 60 units need to be connected, two or more controllers must be used. Each wall mounted controller only manages the units it is connected to.

The **PSM-DI** control is used to manage a series of fan coils, up to a maximum of 60 units (the maximum length of the RS 485 connection cable must not exceed 800 m), from one single control point.



The **PSM-DI** control communicates via a serial line with all the units connected, with the possibility of controlling them all together or individually. In fact, the unique address of each individual fan coil means that all the units can be called at the same time, or the individual unit called, to perform the following functions:

- display the current operating mode, the fan speed, the set point;
- display the room temperature measured on the individual unit;
- turn all the units ON and OFF at the same time or alternatively each unit individually;
- change the operating mode (fan only, heating, cooling, automatic changeover);
- change the set point;
- modify the values and operation parameters of the fan speed.

Each function can then be sent to all the units connected, or alternatively to each individual unit.

Different set points or operating modes can be set for each individual unit.

The **PSM-DI** panel can also be used for the time management of the units over the week. Four ON times and four OFF times can be set on the units for each day of the week. A different Temperature set that will be considered as Operation set for all connected appliances, can be set for each event. If the Temperature set is not entered for the individual event, it must be set during programming for each individual unit or for the entire network.

Units without receiver or with receiver can be connected within the network: the former can receive instructions only from the **PSM-DI** wall mounted panel; while the latter can receive information from both the wall mounted panel (**PSM-DI**) and infra-red remote control. Use the infra-red remote control to force ON mode of the individual unit, if ON/OFF daily time programming has been set. The unit will regain the settings from the **PSM-DI** panel during execution of successive start-up program.

The PSM-DI panel cannot be used together with the Sabianet management program (see next page).

Note: set the configuration Dip Switches of each fan coil as illustrated in the remote control use manual, based on the required solutions.

Note: the RS 485 network's overall length must not exceed 700/800 metres.

Management system for a network of fan coils

Sabianet program **for managing a network of Sabiana MB fan coils**

DESCRIPTION	IDENTIFICATION	CODE
Hardware/software supervisory system (to be used with MB board only)	Sabianet	9079118

Sabianet is a centralised control system for networks of Sabiana MB fan coils, based on software that runs on LINUX™. The **Sabianet** software offers a practical and economical solution for managing the units, with the simple click of the mouse.

The main characteristics include:

- simplicity of use;
- an extremely complete and functional weekly program;
- possibility to access the historical operating data for each individual appliance connected.

The program exploits all the potential of our units with remote controls, representing an addition to the latter.

The **Sabianet** program is a control tool that can be used as a replacement for the remote control, or in parallel, however the settings made using **Sabianet** can have priority over those made using the remote control.

The program can be used to:

- Create uniform groups (groups of units on individual floors, in offices or rooms).
- Save weekly programs configured for different types of operation (summer, winter, mid seasons, closing periods etc.); these can then be recalled and activated with a simple click of the mouse. Weekly on/off cycles can be set for individual units or groups of units.
- Set the operating conditions for each individual unit or groups of units (operating mode, fan speed, temperature setting).
- Set the set point limits for each individual unit or groups of units.
- Switch each individual unit or groups of units ON or OFF.



Management system for a network of fan coils

The main program screen can display and interact with the entire network of units. An individual unit, a group of units or the entire network can be called so as to make modifications to the operating mode and the set point. The user can then check the operating status of each individual unit, read the room temperature, the coil temperature and the operating status of the condensate drain pump or any alarms.

“MONITORING” SCREEN

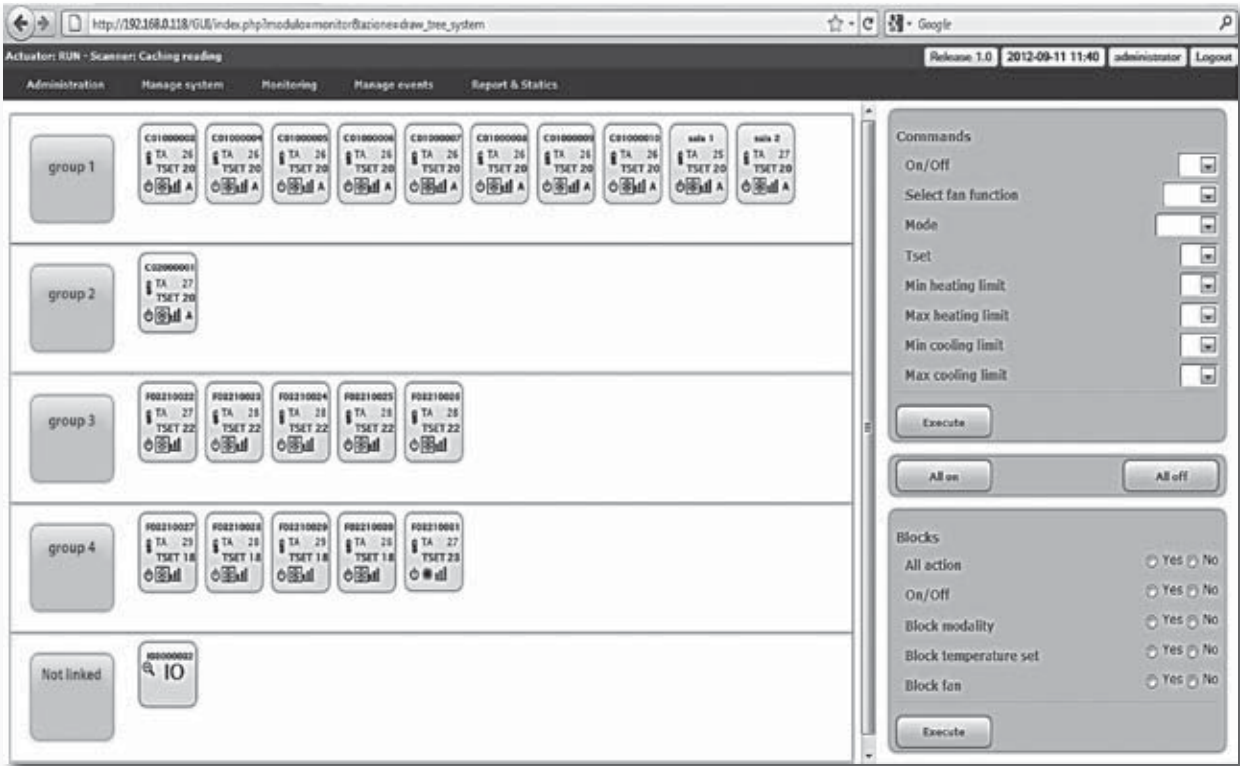

Displaying a unit

The “MONITORING” SCREEN shows the units that are connected to the network and scanned by the program.

The icon of the terminal unit provides the following information:

- Unit name (**C01000001**)
- Set temperature (TSET)
- Room temperature (TA)
- Unit status: ON or OFF
- Mode:
 - Summer
 - Winter
 - Auto
 - Fan only
- Fan speed:
 - Low
 - Medium
 - High
 - AutoFan

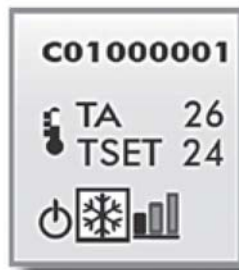

Management system for a network of fan coils

The “Weekly Program” can be used to set the unit operating parameters for each day of the week. Up to 20 different weekly programs can be set.

“EVENT MANAGEMENT” SCREEN

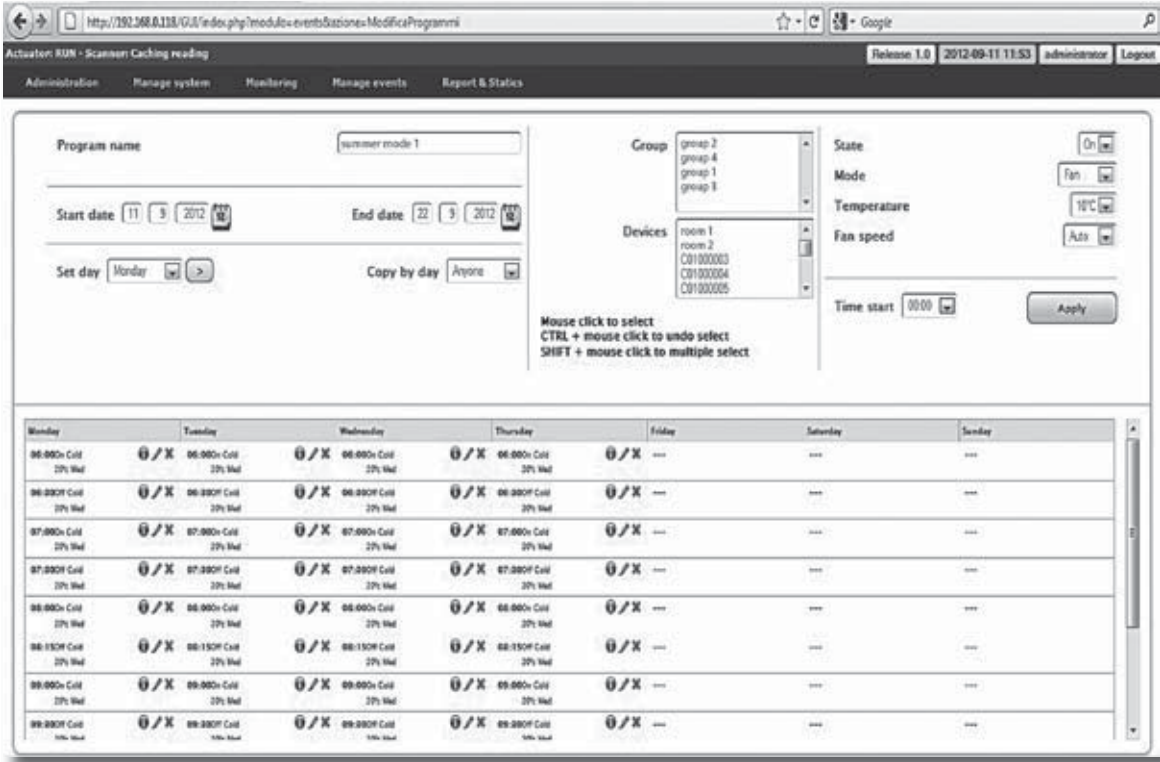

Time bands are available for each day of the week. The time and the type of operation to be performed by the unit can be set for each band. The time and the operating parameters can then be displayed before being sent to the unit and implemented.

PC Sabianet Software

Connection of a **Carisma CRC/CRT/CRS-ECM** network with MB electronic board

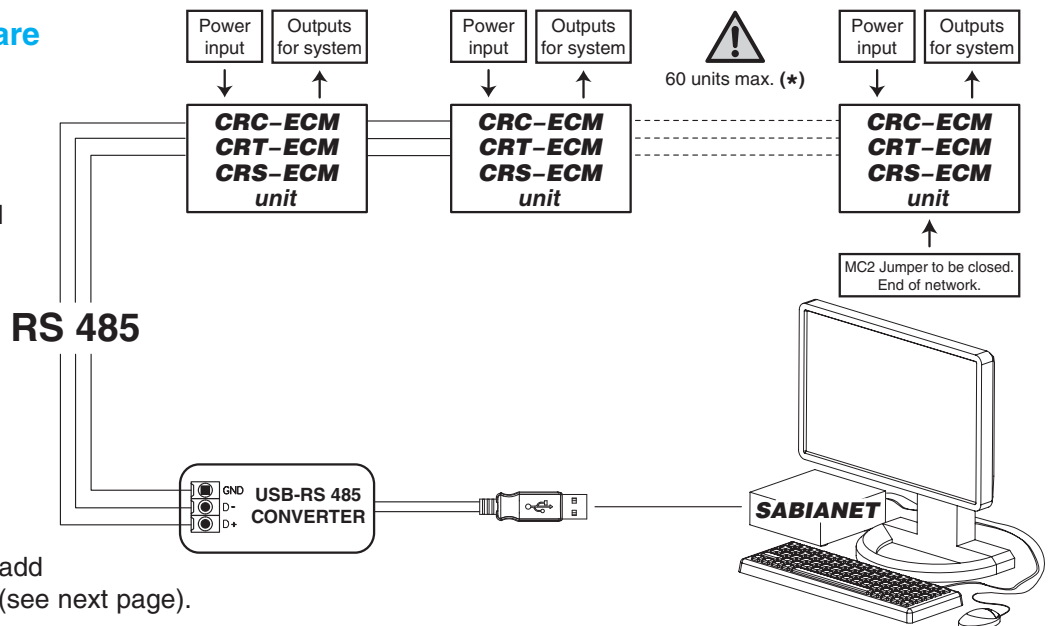

(*) In the event of more than 60 units, add one or more Router-S (see next page).

RS 485 serial connection cable

Shielded cable to be used:
Belden 9841, RS-485, 1x2x24 AWG SFTP, 120 Ohm



PSM-DI and Sabianet electronic boards

IDENTIFICATION	CODE
<i>SIOS</i>	<i>3021092</i>

SIOS is a board equipped with 8 relays with potential free contact to control the activation or deactivation of remote electric utilities. Moreover, the board has 8 digital inlets to display the actuators or external consents, such as motor or other.

The SIOS boards can be connected:

- inside a network managed by Sabianet;
- to a PSM-DI panel (one SIOS for each PSM-DI panel).



IDENTIFICATION	CODE
<i>Router-S</i>	<i>3021290</i>

The Router-S is an electronic board that:

- allows creating networks with more than 60 units (minimum 2 Router-S are required) or to divide the network (per floor, building, etc.);
- it allows creating a Master/Slave sub-network to be controlled as an independent group.

The Router-S can be used

only inside a network managed by Sabianet.

The number of Router-S to be used is: - up to 60 units: no Router-S

- from 61 to 120 units: 2 Router-S

- every 60 subsequent units: 1 additional Router-S

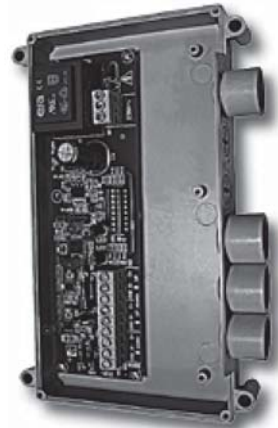



www.icim.it

CERTIFICATO n. 0545/5
CERTIFICATE No. _____

SI CERTIFICA CHE IL SISTEMA DI GESTIONE PER LA QUALITA' DI
WE HEREBY CERTIFY THAT THE QUALITY MANAGEMENT SYSTEM OPERATED BY

SABIANA S.p.A.

UNITA' OPERATIVE
OPERATIVE UNITS

Sede e Unità Operativa
Via Piave, 53 - 20011 Corbetta (MI)
Unità Operativa
Via Virgilio, 2 - 20013 Magenta (MI)
Italia

E' CONFORME ALLA NORMA
IS IN COMPLIANCE WITH THE STANDARD

UNI EN ISO 9001:2008

PER LE SEGUENTI ATTIVITA'
FOR THE FOLLOWING ACTIVITIES

EA: 18

Progettazione, produzione e assistenza di apparecchiature per il riscaldamento e il condizionamento dell'aria (aerotermi, termostrisce radianti, ventilconvettori e unità trattamento aria) e canne fumarie.

Design, production and service of heating and air conditioning equipment (unit heaters, radiant panels, fan coil units and air handling units) and chimneys.

Riferirsi al Manuale della Qualità per l'applicabilità dei requisiti della norma di riferimento.
Refer to Quality Manual for details of application to reference standard requirements.

Il presente certificato è soggetto al rispetto del regolamento per la certificazione dei sistemi di gestione per la qualità delle aziende.
The use and the validity of this certificate shall satisfy the requirements of the rules for the certification of company quality management systems.

Data emissione
First issue
10/06/1996

Emissione corrente
Current issue
10/04/2012

Data di scadenza
Expiring date
09/04/2015

ICIM S.p.A.

Piazza Don Enrico Mapelli, 75 - 20099 Sesto San Giovanni (MI)



SGQ N° 004A SEI N° 0090
SGA N° 005D PRG N° 004B
SCR N° 006F ISP N° 046E

Membro degli Accordi di Mutuo Riconoscimento EA, IAF e ILAC
Signatory of EA, IAF and ILAC Mutual Recognition Agreements

CISQ is a member of



IQNet, the association of the world's first class certification bodies, is the largest provider of management System Certification in the world. IQNet is composed of more than 30 bodies and counts over 150 subsidiaries all over the globe.

CISQ è la Federazione italiana di Organismi di Certificazione dei sistemi di gestione aziendale.

CISQ is the Italian Federation of management system Certification Bodies.



www.cisq.com

The descriptions and illustrations provided in this publication are not binding: Sabiana reserves the right, whilst maintaining the essential characteristics of the types described and illustrated, to make, at any time, without the requirement to promptly update this piece of literature, any changes that it considers useful for the purpose of improvement or for any other manufacturing or commercial requirements.

Air Conditioning
Carisma CRC-ECM / CRT-ECM / CRS-ECM Fan Coil Units



SABIANA
ENVIRONMENTAL COMFORT

Sabiana s.p.a. • via Piave, 53 • 20011 Corbetta • Milano • Italy • phone +39.02.97203.1 r.a. / +39.02.97270429 / +39.02.97270576
fax +39.02.9777282 / +39.02.9772820 • www.sabiana.it • info@sabiana.it

CRC/CRT/CRS-ECM - EX - 04/13
Cod. A4670160 B/04/13