

SkyStar Cassette fan coil unit SK-ECM-HY





The descriptions and illustrations provided in this publication are not binding: **Sabiana** reserves the right, whilst maintaining the essential characteristics of the types described and illustrated, to make, at any time, without the requirement to promptly update this piece of literature, any changes that it considers useful for the purpose of improvement or for any other manufacturing or commercial requirements.

TABLE OF CONTENTS

Introduction	4
SkyStar SK-ECM-HY	
Construction features	5
EUROVENT Certification	6
Cooling emission	8
Heating emission	10
Water side pressure drop	12
Operation limits	13
Dimension and weight	14
Air diffuser (mandatory)	16
Controls	17
Accessories	22



Sabiana take part to the Eurovent program of fan coil performance certification. The official figures are published in the web site www.eurovent-certification.com. The tested performances are:

Total cooling emission at the following conditions:

- | | | |
|---------------------|--------------|---------------|
| • water temperature | +7 °C E.W.T. | +12 °C L.W.T. |
| • air temperature | +27 °C d.b. | +19 °C w.b. |

Heating emission (2 pipe units) at the following conditions:

- | | | |
|---------------------|----------------|---------------|
| • water temperature | +45 °C E.W.T. | +40 °C L.W.T. |
| • air temperature | +20 °C | |
| Static pressure | Fan absorption | |

Sensible cooling emission at the following conditions:

- | | | |
|---------------------|--------------|---------------|
| • water temperature | +7 °C E.W.T. | +12 °C L.W.T. |
| • air temperature | +27 °C d.b. | +19 °C w.b. |

Heating emission (4 pipe units) at the following conditions:

- | | | |
|--------------------------|---------------|---------------|
| • water temperature | +65 °C E.W.T. | +55 °C L.W.T. |
| • air temperature | +20 °C | |
| Water side pressure drop | Sound power | |

INTRODUCTION

The **SkyStar SK-ECM-HY** Cassette fan coil units are the result of an extended technical and design development aimed at achieving the highest level in accordance with the **VDI6022** Standard in terms of performance, silent operation and control possibility.

Ideal for applications in the health sector (hospitals, clinics, retirement homes, laboratories, etc.) and for all environments where a high level of hygiene is required.

The fact that the product can be easily cleaned and fully sanitised helps to reduce maintenance costs and guarantees high safety standards for users.

The compliance to the Standard requirements:

- **VDI6022 Blatt 1 (01/2018)**
- **ONORM H-6021 (01/2023)**
- **SWKIVA104-01 (01/2019)**

It was certified by the **Hygiene Institut des Ruhrgebiets**.

Maximum protection against the proliferation of fungi, bacteria and microorganisms is guaranteed by the use of components made of grade AISI 304 steel or polymeric material certified according to DIN EN ISO 846 criteria; periodic maintenance aimed at ensuring thorough cleaning and disinfection is facilitated by the use of materials capable of withstanding abrasion and detergents and by the product's construction, which allows easy access to the main components and their dismantling as well as the absence of poorly accessible areas.

Moreover, periodic cleaning is also facilitated by the use of light-coloured materials in the most critical areas, which makes it easier to observe the cleaning results.

The unit is exclusively equipped with a gravity condensate drain to prevent water from building up inside it.

Every unit can be supplied with 1 single coil (2 pipe system) or with 2 coils (4 pipe system).

In addition to temperature and speed standard controls, automatic speed selection is also available. More than one unit can be connected to a single control.

All the units can be supplied in the **MB** version.

This version includes a wide range of controls, including the infra-red remote control, which allows managing one single unit or one or more groups of units by using the Modbus RTU - RS 485 communication protocol. The units can be connected to the most common automatic building management systems.

The **SkyStar SK-ECM-HY** range uses an innovative brushless synchronous permanent magnet electric

motor controlled by an inverter board that is directly installed on the unit.

The air flow rate can be varied in continuous by means of a 1-10 V signal generated by Sabiana controls or by independent control systems (programmable controllers with a 1-10 V output).

The extreme efficiency, also at a low speed, makes possible a great reduction in electric consumption (more than 75% less in comparison to a traditional motor) with absorption values, under normal operating conditions, that are no greater than a 10 Watt.

The brushless motor is characterised by a constant synchronous speed, independently of the applied load, that depends only on the motor power supply frequency, which is modulated by the inverter.

It consumes less because:

- the motor always works at its point of maximum efficiency
- in the brushless motor, the rotor's permanent magnets generate the magnetising power autonomously
- the motor always operates at the synchronous speed, as a result there are no induced currents that reduce efficiency.

The main advantages are:

- large reduction in energy consumption, thanks to an optimal response to the thermal load of the environment during every moment of the day
- operating silence at all rotation speeds
- ability to operate at any rotation speed.

CONSTRUCTION FEATURES



Air diffuser

Air inlet grid of AISI304 with 600x600 dimension, to perfectly fit into the standard false ceilings and without overlapping parts.

The air inlet grid is insulated with polymeric material certified according to DIN EN ISO 846 criteria.

The air diffuser is supplied with own packaging and separate code (see p. 16).

Casing

Of galvanized steel insulated on the inside wall in contact with the air; the insulation is made of polyolefin (PO) foam B-s2-d0 EN 13501-01, patented according to DIN EN ISO 846 criteria.

Light-coloured insulation foam to facilitate the periodic cleaning, via visual check.

Fan assembly

The fan assembly, which is mounted on anti-vibrating supports, is extremely silent.

The radial fan has been designed to optimise performance, using wing profile blades with a shape that reduces turbulence, increasing efficiency and reducing noise.

The polymeric material of the fan is certified according to DIN EN ISO 846 criteria.

The fans are connected to a three phase permanent magnet brushless electronic motor that is controlled with reconstructed current according to a BLAC sinusoidal wave.

The inverter board that controls the motor operation is powered by 230 Volt, single-phase and, with a switching system, it generates a three-phase frequency modulated, wave form power supply.

The power supply of the unit is single phase 230-240 Vac 50/60 Hz.

Control devices

- **SK-ECM-HY** version

It consists of the electronic inverter circuit board.

- **SK-ECM-HY-MB** version

It consists of the electronic MB board and of the inverter circuit board.

Coil

Made of copper tubes with bonded aluminium fins for maximum transfer contact.

2 or 3 row coil for 2 pipe models and 2+1 row coil for 4 pipe models (the heating row is on the inside part of the coil).

The coil is not suitable for use in corrosive atmosphere or in environments where aluminium may be subject to corrosion.

Internal condensate collection tray

Of heat-coupled AISI304 with polyolefin (PO) foam, patented according to DIN EN ISO 846 criteria.

Valve set

Two or three way, ON/OFF type, connections included.

EUROVENT CERTIFICATION



2 pipe system

The following standard rating conditions are used:

COOLING

Entering air temperature: + 27 °C d.b. + 19 °C w.b.

Water temperature: +7 °C E.W.T. +12 °C L.W.T.

HEATING

Entering air temperature: + 20 °C

Water temperature: +45 °C E.W.T. +40 °C L.W.T.

MODEL		SK-ECM 12					SK-ECM 22					SK-ECM 32				
		1	3	5	7,5	10	1	3	5	7,5	10	1	3	5	7,5	10
Inverter power		MIN		MED		MAX	MIN		MED		MAX	MIN		MED		MAX
Eurovent certified performances.		(E)	-	(E)	-	(E)	(E)	-	(E)	-	(E)	(E)	-	(E)	-	(E)
Air flow	m ³ /h	310	345	380	457	535	310	377	445	577	710	360	485	610	745	880
Cooling total emission (E)	kW	1,84	2,01	2,16	2,47	2,73	2,24	2,65	3,04	3,71	4,30	2,55	3,25	3,85	4,45	4,96
Cooling sensible emission (E)	kW	1,35	1,47	1,60	1,84	2,07	1,57	1,87	2,16	2,67	3,15	1,80	2,31	2,79	3,25	3,68
Heating emission (E)	kW	1,85	2,04	2,22	2,55	2,87	2,12	2,56	2,98	3,68	4,36	2,46	3,17	3,85	4,52	5,15
Dp Cooling (E)	kPa	4,9	5,8	6,6	8,4	10,1	4,6	6,3	9,4	11,6	15,1	5,9	9,1	12,4	16,2	19,7
Dp Heating (E)	kPa	4,3	5,1	5,9	7,6	9,4	3,6	5,1	6,6	9,7	13,2	4,7	7,5	10,6	14,1	17,8
Sound power (Lw) (E)	dB(A)	33,0	36,0	39,0	43,0	47,0	33,0	38,0	43,0	48,5	54,0	37,0	43,5	50,0	55,0	60,0
Sound pressure (Lp) ⁽¹⁾	dB(A)	24,0	27,0	30,0	34,0	38,0	24,0	29,0	34,0	39,5	45,0	28,0	34,5	41,0	46,0	51,0
Fan (E)	W	5,0	6,5	8,0	12,0	16,0	5,0	8,0	11,0	21,0	31,0	7,0	14,0	21,0	41,5	62,0
Condensate drain pump power absorption	W	10	10	10	10	10	10	10	10	10	10	10	10	10	10	10
Water content	l	1,4	1,4	1,4	1,4	1,4	2,1	2,1	2,1	2,1	2,1	2,1	2,1	2,1	2,1	2,1
Length	mm	575	575	575	575	575	575	575	575	575	575	575	575	575	575	575
Depth	mm	575	575	575	575	575	575	575	575	575	575	575	575	575	575	575
Height	mm	275	275	275	275	275	275	275	275	275	275	275	275	275	275	275

(E) Eurovent certified performance.

⁽¹⁾ The sound pressure levels are 9 dB (A) lower than the sound power levels, apply to the reverberant field of a 100 m³ room and a reverberation time of 0.5 sec.

4 pipe system

The following standard rating conditions are used:



COOLING

Entering air temperature: + 27 °C d.b. + 19 °C w.b.

Water temperature: +7 °C E.W.T. +12 °C L.W.T.

HEATING

Entering air temperature: + 20 °C

Water temperature: +65 °C E.W.T. +55 °C L.W.T.

MODEL	Inverter power	SK-ECM 14					SK-ECM 26					SK-ECM 36				
		1	3	5	7,5	10	1	3	5	7,5	10	1	3	5	7,5	10
Eurovent certified performances.		MIN (E)	-	MED (E)	-	MAX (E)	MIN (E)	-	MED (E)	-	MAX (E)	MIN (E)	-	MED (E)	-	MAX (E)
Air flow	m ³ /h	310	345	380	457	535	310	377	445	577	710	360	485	610	745	880
Cooling total emission (E)	kW	1,85	2,02	2,17	2,48	2,75	2,09	2,46	2,81	3,39	3,90	2,37	2,99	3,51	4,03	4,47
Cooling sensible emission (E)	kW	1,34	1,31	1,59	1,64	2,06	1,49	1,76	2,03	2,49	2,92	1,70	2,17	2,60	3,01	3,40
Heating emission (E)	kW	2,13	2,32	2,51	2,85	3,18	1,73	1,97	2,20	2,57	2,91	1,92	2,31	2,66	2,99	3,29
Dp Cooling (E)	kPa	4,6	5,4	6,2	7,9	9,5	3,3	4,4	5,6	7,9	10,3	4,1	6,3	8,4	10,9	13,1
Dp Heating (E)	kPa	4,6	5,3	6,1	7,7	9,4	2,6	3,3	4,1	5,4	6,7	3,2	4,4	5,7	7,1	8,4
Sound power (Lw) (E)	dB(A)	33,0	36,0	39,0	43,0	47,0	33,0	38,0	43,0	48,5	54,0	37,0	43,5	50,0	55,0	60,0
Sound pressure (Lp) ⁽¹⁾	dB(A)	24,0	27,0	30,0	34,0	38,0	24,0	29,0	34,0	39,5	45,0	28,0	34,5	41,0	46,0	51,0
Fan (E)	W	5,0	6,5	8,0	12,0	16,0	5,0	8,0	11,0	21,0	31,0	7,0	14,0	21,0	41,5	62,0
Condensate drain pump power absorption	W	10	10	10	10	10	10	10	10	10	10	10	10	10	10	10
Cooling water content	l	1,4	1,4	1,4	1,4	1,4	1,7	1,7	1,7	1,7	1,7	1,7	1,7	1,7	1,7	1,7
Heating water content	l	0,7	0,7	0,7	0,7	0,7	0,5	0,5	0,5	0,5	0,5	0,5	0,5	0,5	0,5	0,5
Length	mm	575	575	575	575	575	575	575	575	575	575	575	575	575	575	575
Depth	mm	575	575	575	575	575	575	575	575	575	575	575	575	575	575	575
Height	mm	275	275	275	275	275	275	275	275	275	275	275	275	275	275	275

(E) Eurovent certified performance.

⁽¹⁾ The sound pressure levels are 9 dB (A) lower than the sound power levels, apply to the reverberant field of a 100 m³ room and a reverberation time of 0.5 sec.

COOLING EMISSION

Models with single coil (2 pipe installations)

Entering air temperature: 27 °C – R.H.: 50%

Model	Vdc	WT: 7 / 12 °C			WT: 8 / 13 °C			WT: 10 / 15 °C			WT: 12 / 17 °C			
		Qv m ³ /h	Pc kW	Ps kW	Qw l/h	Pc kW	Ps kW	Qw l/h	Pc kW	Ps kW	Qw l/h	Pc kW	Ps kW	Qw l/h
SK-ECM-HY 12	10	535	2,94	2,06	506	2,64	1,94	455	1,78	1,78	307	1,53	1,53	263
	7,5	457	2,64	1,84	455	2,38	1,73	409	1,88	1,52	323	1,36	1,36	234
	5	380	2,32	1,60	399	2,09	1,50	360	1,65	1,32	284	1,20	1,20	206
	3	345	2,15	1,47	370	1,94	1,38	334	1,54	1,22	264	1,10	1,10	190
	1	310	1,97	1,34	339	1,78	1,26	307	1,41	1,11	242	1,00	1,00	173
SK-ECM-HY 22	10	710	4,61	3,14	792	4,16	2,95	716	3,29	2,60	566	2,35	2,35	404
	7,5	577	3,96	2,67	681	3,59	2,51	617	2,85	2,20	490	2,20	1,93	379
	5	445	3,25	2,16	559	2,95	2,03	508	2,35	1,78	403	1,81	1,56	312
	3	377	2,83	1,87	487	2,57	1,76	442	2,06	1,54	354	1,59	1,35	274
	1	310	2,39	1,56	410	2,17	1,47	373	1,75	1,29	300	1,35	1,13	232
SK-ECM-HY 32	10	880	5,32	3,67	916	4,80	3,45	825	3,80	3,04	653	2,74	2,74	471
	7,5	745	4,75	3,24	817	4,29	3,05	738	3,40	2,69	585	2,43	2,43	417
	5	610	4,13	2,79	710	3,74	2,62	643	2,97	2,31	510	2,29	2,02	394
	3	485	3,46	2,31	596	3,14	2,17	541	2,49	1,91	429	1,93	1,67	332
	1	360	2,73	1,80	470	2,48	1,69	426	1,99	1,49	342	1,54	1,30	264

WT: Water temperature
Vdc: Inverter power
Qv: Air flow
Pc: Cooling total emission
Ps: Cooling sensible emission
Qw: Water flow rate

Models with double coil (4 pipe installations)

Entering air temperature: 27 °C – R.H.: 50%

Model	Vdc	WT: 7 / 12 °C			WT: 8 / 13 °C			WT: 10 / 15 °C			WT: 12 / 17 °C			
		Qv m ³ /h	Pc kW	Ps kW	Qw l/h	Pc kW	Ps kW	Qw l/h	Pc kW	Ps kW	Qw l/h	Pc kW	Ps kW	Qw l/h
SK-ECM-HY 14	10	535	2,95	2,05	508	2,66	1,93	458	1,77	1,77	305	1,52	1,52	261
	7,5	457	2,65	1,83	456	2,39	1,72	412	1,89	1,52	325	1,37	1,37	235
	5	380	2,33	1,59	401	2,10	1,50	362	1,66	1,32	286	1,19	1,19	204
	3	345	2,16	1,47	371	1,95	1,38	336	1,54	1,21	265	1,09	1,09	188
	1	310	1,98	1,33	340	1,79	1,26	308	1,41	1,10	242	0,99	0,99	171
SK-ECM-HY 26	10	710	4,19	2,91	720	3,77	2,73	648	2,98	2,41	513	2,16	2,16	372
	7,5	577	3,62	2,49	623	3,27	2,34	562	2,59	2,06	446	1,85	1,85	319
	5	445	3,00	2,03	516	2,71	1,91	467	2,15	1,68	369	1,52	1,52	261
	3	377	2,63	1,76	452	2,38	1,66	409	1,90	1,46	326	1,46	1,28	251
	1	310	2,23	1,48	383	2,02	1,39	347	1,61	1,22	277	1,24	1,07	214
SK-ECM-HY 36	10	880	4,80	3,38	826	4,31	3,18	742	3,41	2,81	586	2,51	2,51	431
	7,5	745	4,31	3,00	742	3,88	2,82	667	3,06	2,49	527	2,23	2,23	384
	5	610	3,77	2,60	649	3,40	2,44	585	2,69	2,15	462	1,94	1,94	333
	3	485	3,19	2,17	548	2,88	2,04	496	2,28	1,79	393	1,62	1,62	278
	1	360	2,54	1,70	436	2,30	1,60	395	1,83	1,40	314	1,41	1,23	243

WT: Water temperature
Vdc: Inverter power
Qv: Air flow
Pc: Cooling total emission
Ps: Cooling sensible emission
Qw: Water flow rate

HEATING EMISSION

Models with single coil (2 pipe installations)

Entering air temperature: +20 °C

Model	Vdc	Qv m ³ /h	WT: 70 / 60 °C		WT: 60 / 50 °C		WT: 55 / 45 °C		WT: 50 / 40 °C		WT: 45 / 40 °C	
			Ph kW	Qw l/h	Ph kW	Qw l/h	Ph kW	Qw l/h	Ph kW	Qw l/h	Ph kW	Qw l/h
SK-ECM-HY 12	10	535	5,82	500	4,49	387	3,83	330	3,17	272	2,87	247
	7,5	457	5,16	444	3,99	343	3,41	293	2,82	243	2,55	219
	5	380	4,51	387	3,49	300	2,99	257	2,48	213	2,22	191
	3	345	4,13	355	3,21	276	2,74	236	2,28	196	2,04	176
	1	310	3,75	322	2,91	250	2,49	214	2,07	178	1,85	159
SK-ECM-HY 22	10	710	8,81	758	6,85	589	5,87	505	4,89	420	4,36	375
	7,5	577	7,44	640	5,80	499	4,97	428	4,15	357	3,68	317
	5	445	6,01	517	4,70	404	4,04	347	3,38	290	2,98	256
	3	377	5,16	444	4,05	348	3,48	300	2,92	251	2,56	220
	1	310	4,28	368	3,36	289	2,90	249	2,43	209	2,12	183
SK-ECM-HY 32	10	880	10,42	896	8,09	696	6,92	595	5,75	494	5,15	443
	7,5	745	9,14	786	7,11	611	6,09	524	5,06	435	4,52	389
	5	610	7,79	670	6,07	522	5,20	448	4,34	373	3,85	331
	3	485	6,41	551	5,01	430	4,30	370	3,59	309	3,17	273
	1	360	4,96	427	3,89	335	3,35	288	2,81	241	2,46	212

WT: Water temperature
Vdc: Inverter power
Qv: Air flow
Ph: Heating emission
Qw: Water flow rate

Models with double coil (4 pipe installations)

Entering air temperature: +20 °C

Model	Vdc	Qv m ³ /h	WT: 70 / 60 °C		WT: 60 / 50 °C		WT: 55 / 45 °C		WT: 50 / 40 °C		WT: 45 / 40 °C	
			Ph kW	Qw l/h	Ph kW	Qw l/h	Ph kW	Qw l/h	Ph kW	Qw l/h	Ph kW	Qw l/h
SK-ECM-HY 14	10	535	3,62	311	2,74	236	2,30	198	1,87	161	1,78	305
	7,5	457	3,24	279	2,46	212	2,07	178	1,68	144	1,59	274
	5	380	2,85	245	2,16	186	1,82	156	1,48	127	1,40	241
	3	345	2,64	227	2,01	172	1,69	145	1,37	118	1,30	223
	1	310	2,43	209	1,84	158	1,55	133	1,26	108	1,19	205
SK-ECM-HY 26	10	710	3,35	288	2,48	213	2,04	176	1,61	139	1,62	279
	7,5	577	2,96	254	2,19	189	1,81	156	1,43	123	1,43	247
	5	445	2,53	217	1,87	161	1,55	133	1,23	106	1,23	211
	3	377	2,27	195	1,68	145	1,39	120	1,11	95	1,10	189
	1	310	1,98	170	1,47	127	1,22	105	0,97	83	0,96	165
SK-ECM-HY 36	10	880	3,79	326	2,80	241	2,31	198	1,82	156	1,83	315
	7,5	745	3,44	296	2,54	219	2,10	181	1,66	142	1,67	286
	5	610	3,06	263	2,27	195	1,87	161	1,48	127	1,48	255
	3	485	2,66	229	1,97	170	1,63	140	1,29	111	1,29	222
	1	360	2,20	189	1,64	141	1,36	117	1,08	93	1,07	184

WT: Water temperature
 Vdc: Inverter power
 Qv: Air flow
 Ph: Heating emission
 Qw: Water flow rate

WATER SIDE PRESSURE DROP

2 pipe system

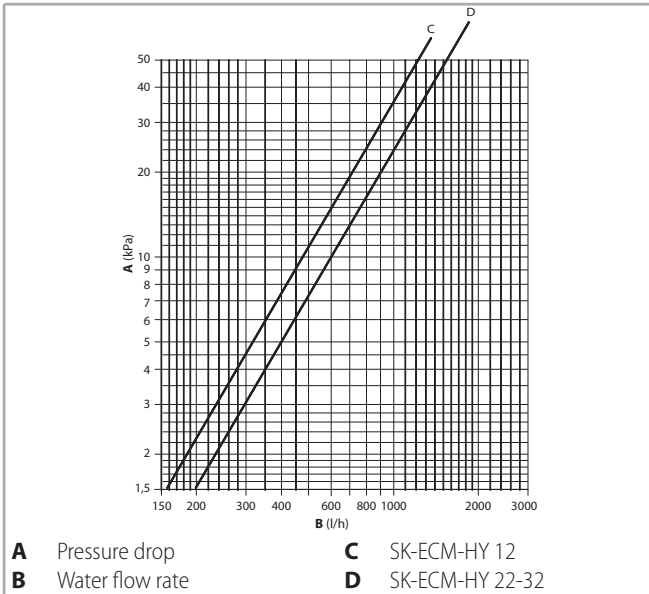

The water pressure drop figures refer to a mean water temperature of 10 °C; for different temperatures, multiply the pressure drop figures by the correction factors K.

K correction factor	Mean water temperature (°C)						
	20	30	40	50	60	70	80
	0,94	0,90	0,86	0,82	0,78	0,74	0,70

4 pipe system

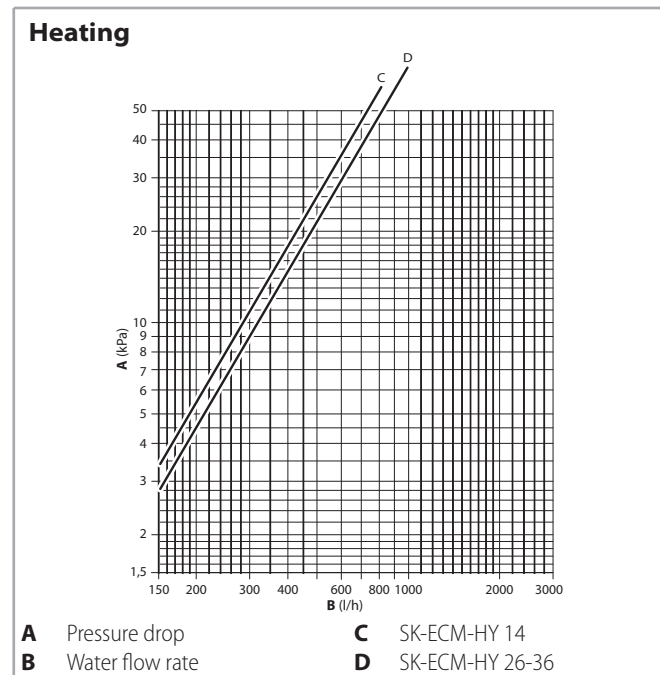
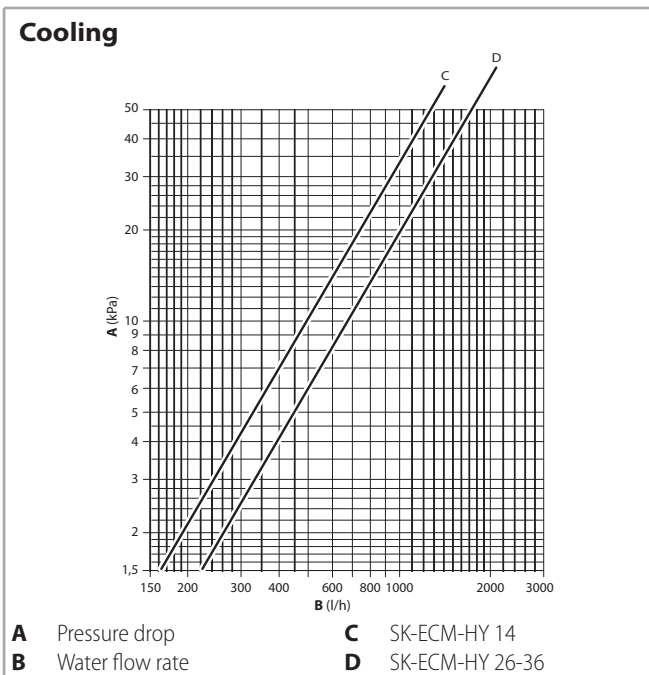

The water pressure drop figures refer to a mean water temperature of 10 °C; for different temperatures, multiply the pressure drop figures by the correction factors K.

K correction factor	Mean water temperature (°C)						
	20	30	40	50	60	70	80
	0,94	0,90	0,86	0,82	0,78	0,74	0,70

The water pressure drop figures refer to a mean water temperature of 60 °C; for different temperatures, multiply the pressure drop figures by the correction factors K.

K correction factor	Mean water temperature (°C)			
	40	50	70	80
	1,12	1,06	0,94	0,88

OPERATION LIMITS

Description		UoM	Value
Water flow	Max. water side pressure	bars	10
		kPa	1000
	Lowest water inlet temperature	°C	+6
	Highest water inlet temperature	°C	+80
Power supply	Single-phase rated operating voltage	V/Hz	230/50-60



DIMENSION AND WEIGHT

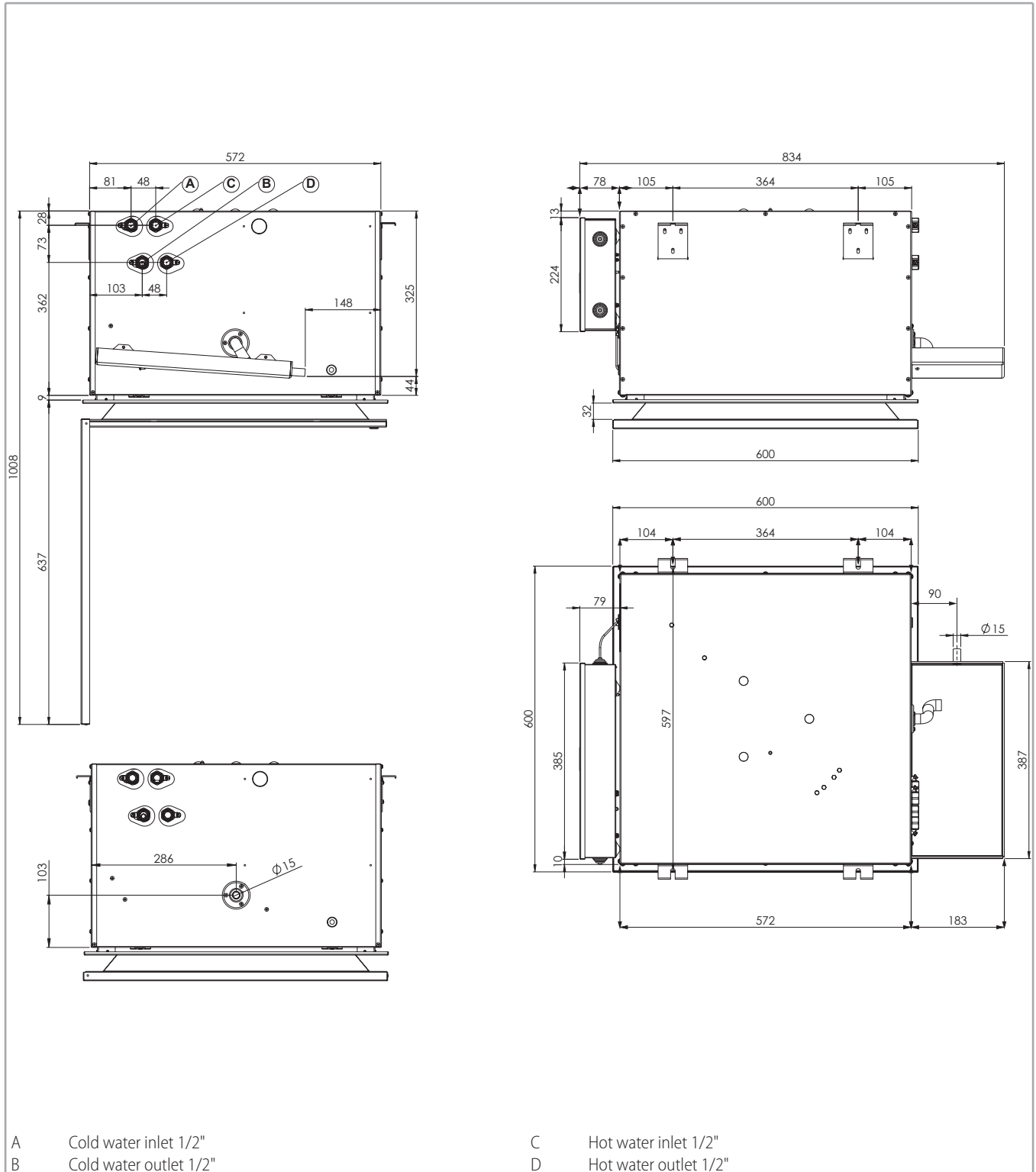

Packed unit

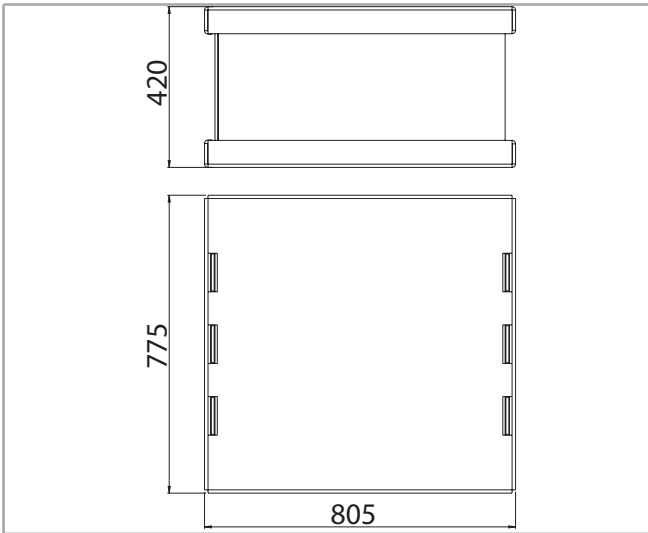

Mod.	Unit	
	Weight with packaging (kg)	Weight without packaging (kg)
SK-ECM-HY 12	30	27
SK-ECM-HY 14	32	29
SK-ECM-HY 22		
SK-ECM-HY 26		
SK-ECM-HY 32		
SK-ECM-HY 36		

SkyStar SK-ECM-HY | AIR DIFFUSER (MANDATORY)

AIR DIFFUSER (MANDATORY)



Model	ID	Code
All	MD-600-IX	9K79110

Packaging

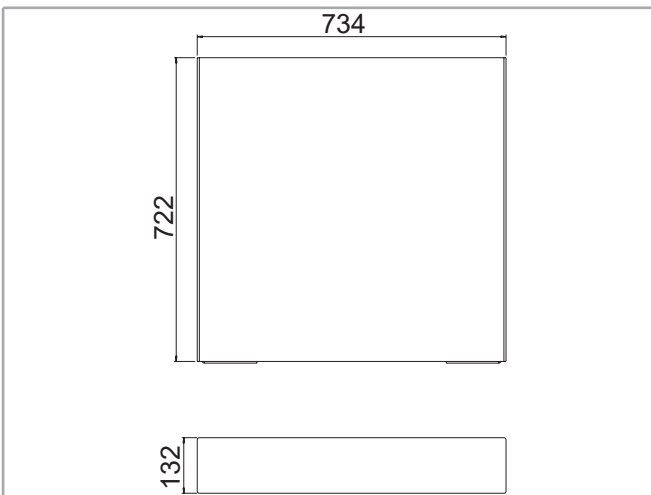

	Weight with packaging	Weight without packaging
kg	8	7

CONTROLS

SK-ECM-HY version

For this Cassette configuration, the 1-10 Vdc signal, which controls the inverter, must be supplied by a controller with the following signal specifications:

Fan coil control signal

- Fan OFF = 0 Vdc
- Fan ON > 1 Vdc
- Max. speed = 10 Vdc

ECM Blac inverter board

- 0÷10 Vdc Circuit Input Impedance Value = 68 kOhm

Power supply

230 Vac 1 Ph 50-60 Hz

Controls

The units of the **SkyStar SK-ECM-HY** range can be supplied with the **T-MB2** wall control that allows managing one single unit or several units (with the use of the power units).

The **T-MB2** electronic thermostat controls the room temperature precisely and is suitable when the user wants to set the fan speed.

Note: all the controls are described in detail in the "Fan Coil Control Range literature".

T-MB2 control (*)



230 V 50-60 Hz

(*) To be used with UPM-AU or UP-AU.

Control systems

See from p. 18 for:

- the MB controls and units
- the KNX Bus System

SK-ECM-HY-MB version with MB power board

The MB power board, mounted as standard on the **SK-ECM-HY-MB** version, is set to carry out different functions and adjustment modes, in order to meet the installation requirements.

The Dip Switches on the board have to be set to carry out different functions:

- 2/4 pipe unit
- electronic room thermostat or automatic fan speed modulation for fan control (ON-OFF)
- electronic room thermostat for valve control (ON-OFF) (the fan keeps working)
- simultaneous thermostatic control of the valves and fan
- fan operation control depending on the coil temperature (fitted T3 low temperature cut-out thermostat), which can be activated only in heating mode or heating and cooling mode
- automatic switch of the operating mode by means of T2 water probe (optional) applied on the 2 pipe system
- Summer/Winter switch by means of remote contact
- ON/OFF of the fan coil by means of the remote contact (window or clock contact)
- electric heater control

By activating the T3 low temperature cut-out thermostat function, the fan is stopped in winter when the coil temperature is lower than 32 °C and started when the temperature reaches 36 °C. In summer mode, the

fan stops when inside the coil exceeds 22 °C and starts when it drops below 18 °C.

The following connections are located on the power board:

- receiver for infra-red remote control
- T-MB2 wall control
- serial connection to manage several fan coil units in Master/Slave configuration or to create a supervisory network.

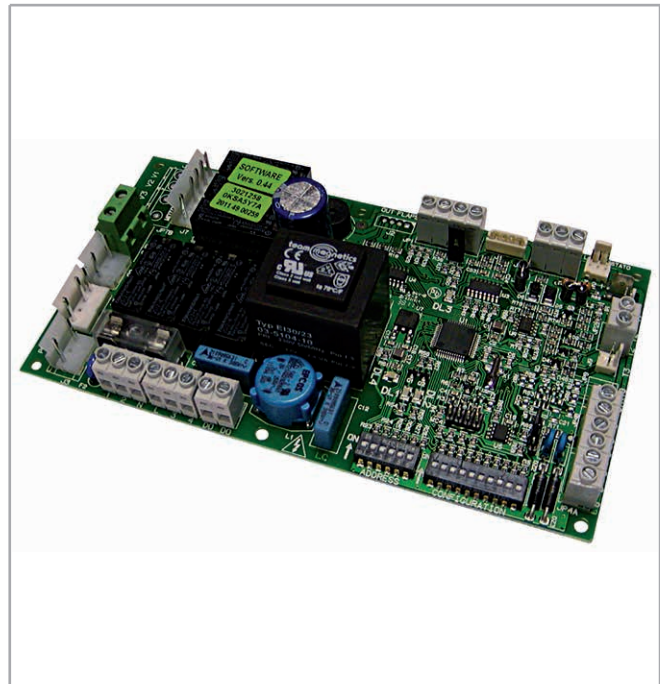

MB controls and units

The **SK-ECM-HY-MB** includes a wide range of controls, including the remote control, which allows to manage one single unit or one or more groups of units by using the Modbus RTU - RS 485 communication protocol.

The groups of units can be managed according to the Master/Slave logic (up to 20 units) or by supervisory components.

The system includes a single MB power board and a range of technical devices to be used with:

- the **T-MB2** wall control and the **infra-red remote control** to manage single units;
- the **PSM-DI** multifunctional panel, the **Sabianet** supervisory system, the **T-DI Touch screen multifunction control panel** and the **SabWeb** Web gateway for Sabiana Cloud, to manage one single unit or several units.

Note: all the controls are described in detail in the "Fan Coil Control Range literature".

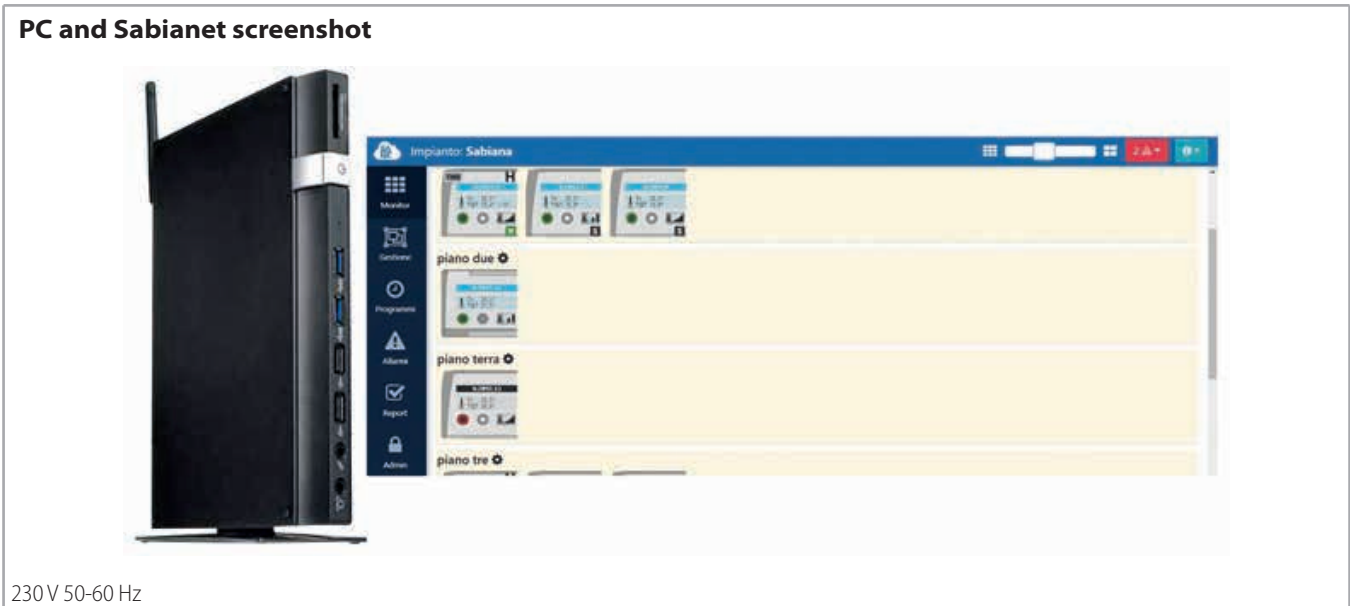

T-DI Touch screen multifunction control panel

The T-DI multifunction control panel lets supervise and control more units with MB or SIOS boards; the panel is equipped with a 7 inches touch screen display and a serie of graphical pages that allows an easy reading of the data sent by the fan coils and the management of up to 60 units (max. 60 units: SIOS + MB).

With the multifunction control panel T-DI it is also possible to control the units remotely with the specific Sabiana Cloud App for Android and iOS.

The Sabiana Cloud application is simple to use and lets have complete control of all the connected units.

T-DI Touch screen multifunction control panel



Web gateway for Cloud

With the Web gateway for "Sabiana Cloud" it is possible to control at a distance up to 60 units, equipped with MB or SIOS boards (max. 60 units: SIOS + MB), with the specific APP for Android and iOS.

The "Sabiana Cloud" APP is simple to use and lets have complete control of all the connected units.

Web gateway for Cloud



PSM-DI Multifunction control panel

With the PSM-DI multifunction control panel it is possible to manage up to 60 units that are equipped with MB electronic board or SIOS (max. 60 units: SIOS + MB).

The PSM-DI multifunction control panel supervises via Bus network all the connected units.

The remote connection (stand-alone) is not possible.

PSM-DI multifunction control panel



230 V 50-60 Hz

KNX Bus System

The KNX bus system is a building automation standard for controlling, managing and monitoring a wide range of products for:

- Heating, cooling, ventilation.
- Lighting.
- Alarm systems.
- Audio and video systems.
- Electricity and gas.

Since 2016, Sabiana is a certified member of the KNX association and the certified products can be added to this system in compliance with the tests carried out at KNX laboratories.



KNX devices

The Sabiana WM-KNX room thermostat controls and adjusts the temperature of a room or area in a building. In combination with one or several UP-KNX power units, the thermostat is able to control the operation of terminal units such as fan coils. The appliance consists of an

LCD display with adjustable backlight and a sensor for measuring the room temperature.

WM-KNX is suitable for installation in a wall recessed box (to be used with UP-KNX and with PL mounting plate only).

Note: all the controls are described in detail in the "Fan Coil Control Range literature".

Recessed thermostat WM-KNX



Power unit UP-KNX



WM-KNX with rectangular plate



WM-KNX with square plate



ACCESSORIES

Kit for hydraulic and electrical connections on the same side

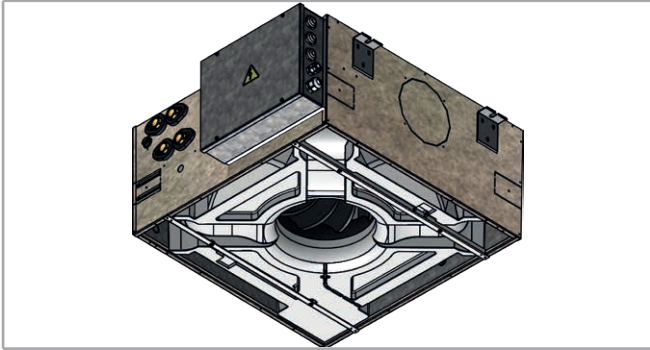

The kit is supplied only factory mounted.

The kit can not be used with valve standard kits from p. 23.

Kit for hydraulic and electrical connections on the same side for SK-ECM-HY version

Version without MB board

Model	ID	Code
SK-ECM-HY 1÷3	KAL-SK-ECM-HY 1-3	9K79111

Version with MB board

Model	ID	Code
SK-ECM-MB-HY 1÷3	KAL-SK-ECM-HY-MB 1-3	9K79112

Version with fitted UP-AU board

Model	ID	Code
SK-ECM-HY 1÷3	KAL-SK-ECM-HY-UP 1-3	9K79113

The kit can not be used with valve standard kits from p. 23.

3 ways ON-OFF valves with actuator with interception valve

Valve kit with 3 ways ON-OFF valves and with thermoelectric actuator; the kit includes connection pipes.

3 ways valves + micrometric lockshield valve connection kit

Model	Valve fitted on the unit		Valve not fitted on the unit		Coil	Micrometric lockshield valve connections ø (female)	Kvs m ³ /h	Dp max kPa*
	ID	Code	ID	Code				
12-22-32	3V2T1-3-M	9079510	3V2T1-3	9079500	main	1/2"	2,5	50
14-26-36	3V4T1-3-M	9079512	3V4T1-3	9079502	main	1/2"	2,5	50
					secondary	1/2"	2,5	50

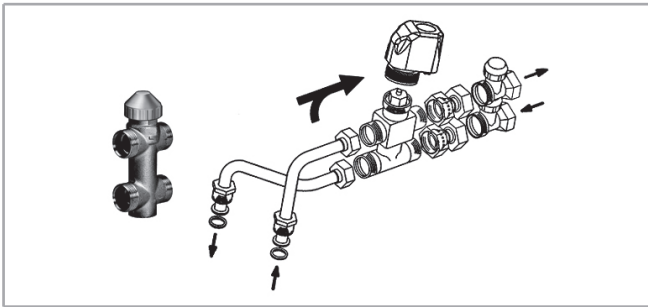

For technical data, operation limits and valves pressure drop, see p. 25.

2 ways ON-OFF valves with actuator with interception valve

Valve kit with 2 ways ON-OFF valves and with thermoelectric actuator; the kit includes connection pipes.

2 ways valves + micrometric lockshield valve connection kit

Model	Valve fitted on the unit		Valve not fitted on the unit		Coil	Micrometric lockshield valve connections ø (female)	Kvs m ³ /h	Dp max kPa*
	ID	Code	ID	Code				
12-22-32	2V2T1-3-M	9079515	2V2T1-3	9079505	main	1/2"	2,8	50
14-26-36	2V4T1-3-M	9079517	2V4T1-3	9079507	main	1/2"	2,8	50
					secondary	1/2"	2,8	50

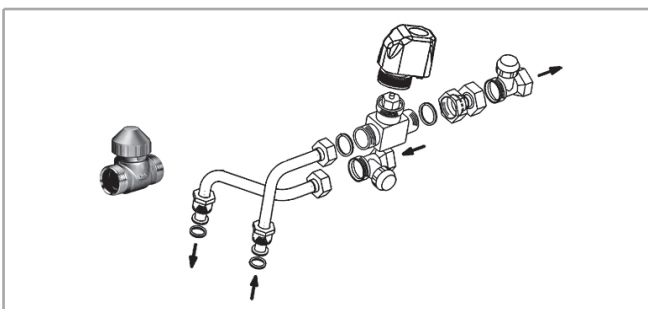

For technical data, operation limits and valves pressure drop, see p. 25.

3 ways ON-OFF valves with actuator, without interception valve

Valve kit with 3 ways ON-OFF valves and with thermoelectric actuator; the kit includes connection pipes.

3 ways valves + simplified connection kit

Model	Valve fitted on the unit		Valve not fitted on the unit		Coil	Valve connection ø (male)	Kvs m ³ /h	Dp max kPa*
	ID	Code	ID	Code				
12-22-32	3VS2T1-3-M	9079530	3VS2T1-3	9079520	main	3/4"	2,5	50
14-26-36	3VS4T1-3-M	9079532	3VS4T1-3	9079522	main	3/4"	2,5	50
					secondary	3/4"	2,5	50

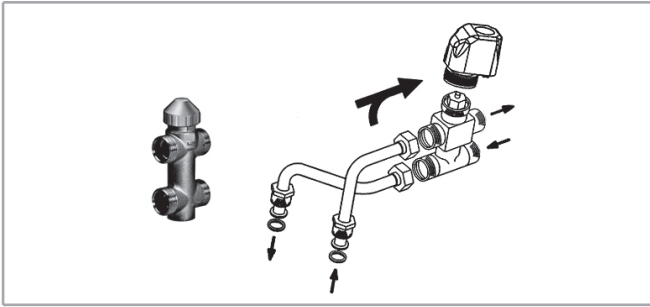

For technical data, operation limits and valves pressure drop, see p. 25.

2 ways ON-OFF valves with actuator, without interception valve

Valve kit with 2 ways ON-OFF valves and with thermoelectric actuator; the kit includes connection pipes.

2 ways valves + simplified connection kit

Model	Valve fitted on the unit		Valve not fitted on the unit		Coil	Valve connection ø (male)	Kvs m ³ /h	Dp max kPa*
	ID	Code	ID	Code				
12-22-32	2VS2T1-3-M	9079535	2VS2T1-3	9079525	main	3/4"	2,8	50
14-26-36	2VS4T1-3-M	9079537	2VS4T1-3	9079527	main	3/4"	2,8	50
					secondary	3/4"	2,8	50

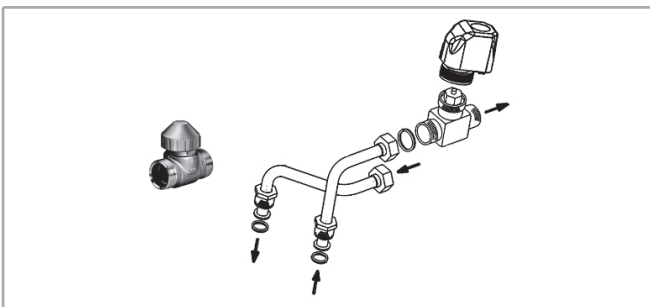

For technical data, operation limits and valves pressure drop, see p. 25.

Valves technical data and operation limits

Description	UoM	Value
Max. working pressure	bars	16
Max. ambient temperature	°C	50
Max. water temperature	°C	110
Power supply	V-Hz	230-50/60
Rating	VA	2,5
Protection		IP 44
Travel time	min	ca. 3
Max. glycol content of water	%	50

Note: The maximum pressure drop across the fully open valve should not exceed 25 kPa for cooling operation and 15 kPa for heating operation.

Valves pressure drop

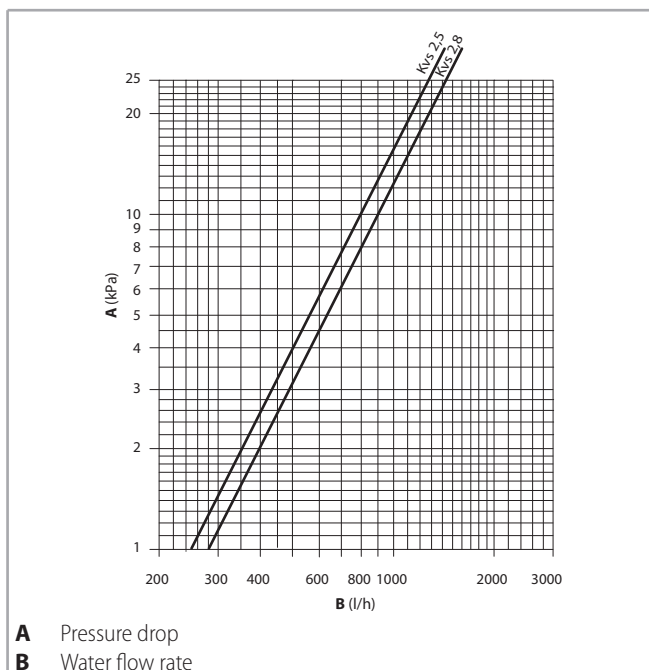

Balance valve with actuator

Balancing valves independent from the system pressure.

- The balancing valve and a combined 2 way valve allow the regulation of the water flow value autonomously, regardless of the system pressure, and the control of the flow by using an ON/OFF electro-thermal actuator.
- The balancing valve allows you to balance the hydraulic system by supplying the required water flow, for each fan-coil, and to maintain it even under partial load conditions.
- A graduated ring nut allows you to set the flow rate value and also allows direct reading of the set value.

Valve operation logic

- "p1" the valve inlet pressure.
- "p3" the outlet pressure.
- "p2" the diaphragm activation pressure, which allows differential pressure "p2" – "p3" to be maintained at a constant value, in order to guarantee the water to flow at the set value.

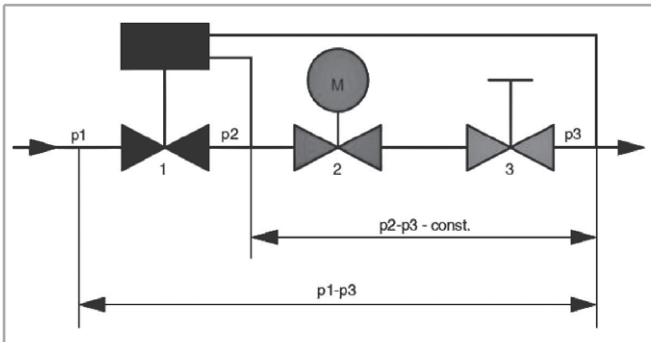

The minimum differential pressure "p1" – "p3", required to guarantee the correct value of the set water flow rate, is indicated in the diagrams and in the related tables.

This is an essential factor to size the system pressure drop and pump pressure head.

The flow rate is kept at a constant value only if the valve pressure drop is higher than the indicated value.

Minimum operating differential pressure

The minimum differential pressure and the balancing valve pressure drop must be considered to size the system pumps.

Flow rate is constant if the pressure drop is higher than that indicated in the diagrams and into the related tables.

The following diagram shows an example of the flow rate trend according to the pressure drop and calibration required.

Example

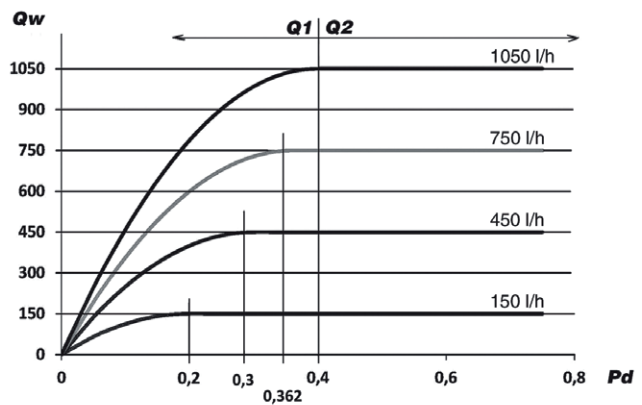

Qw = Water flow rate
 Pd = Min. differential pressure "p1" - "p3" (bar)
 Q1 = Area with inconstant water flow
 Q2 = Area with constant water flow

Kit with OVENTROP valve

In case of Oventrop valves, the valve upstream-downstream minimum differential pressure ("p1" – "p3"), which depends on the valve calibration value, must be exceeded to access the constant flow rate field.

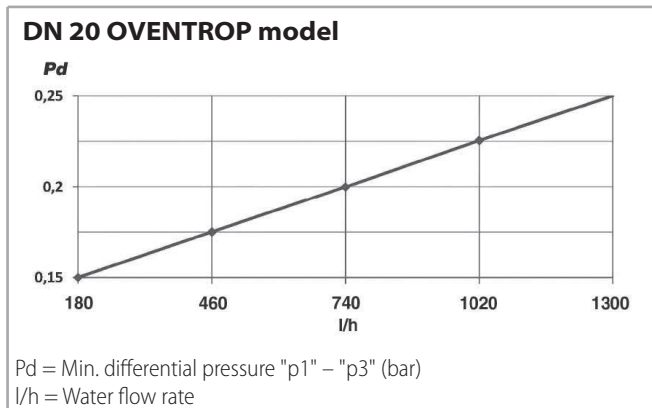
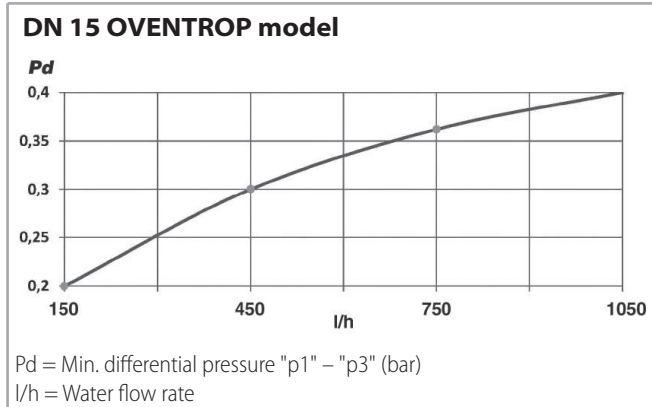

E.g., when sizing the system pump, in which the DN 15 valves will be installed and in which 450 l/h are constantly required for each device, consider a useful pressure of 0.3 bar (to compensate the pressure drop of the valve) for each balancing valve. Therefore, the pressure drop values produced by the system balancing valves must be summed and the pump must be sized to produce a pressure equal to or greater than the value obtained previously.

Benefits

- Reduced dimensions.
- Easy installation on 2 or 4 pipe devices.
- Easy visualization of the nominal set value.
- Guarantee of constant flow rate set even with partial loads.
- Pre-regulation can be blocked and leaded with the locking ring.

OVENTROP technical characteristics

DN model	Flow rate range (l/h)	Kvs
DN 15	150 - 1050	1,8
DN 20	180 - 1300	2,5

Operation limits of the OVENTROP balancing valves

- Maximum operating temperature: 120 °C
- Highest working pressure: 16 bar
- Maximum % of water/glycol mixture: 50%
- Minimum operating temperature: -10 °C
- Maximum differential pressure: 4 bar

Balancing valves for OVENTROP main coil

2 way valve for main coil and assembly kit.

The valve is supplied equipped with 230 Volt electro-thermal actuator for the ON/OFF control.

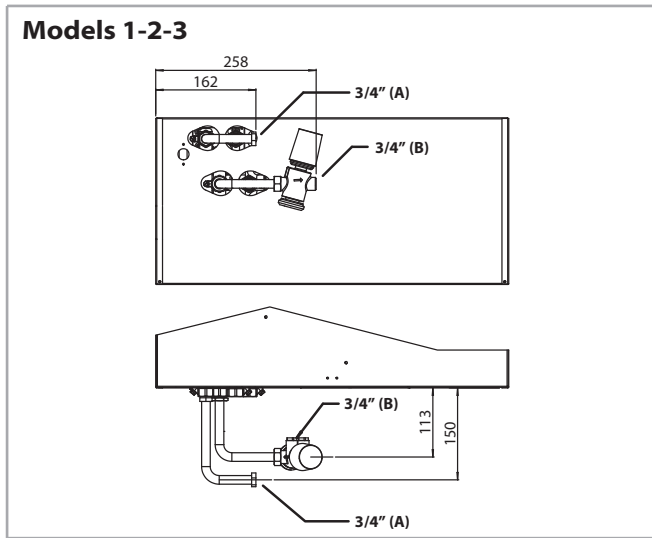

(A) = Water inlet - Female connection

(B) = Water outlet - Male connection

Model	Valve fitted on the unit		Valve not fitted on the unit		DN	(∅)	Qwr
	ID	Code	ID	Code			
1-2-3	V20VSK6BPM 150-1050	9079771	V20VSK6BPS 150-1050	9079761	15	3/4"	150-1050

Balancing valves for OVENTROP main and additional coil

2 way valve for main and additional coil and assembly kit.

The valve is supplied equipped with 230 Volt electro-thermal actuator for the ON/OFF control.

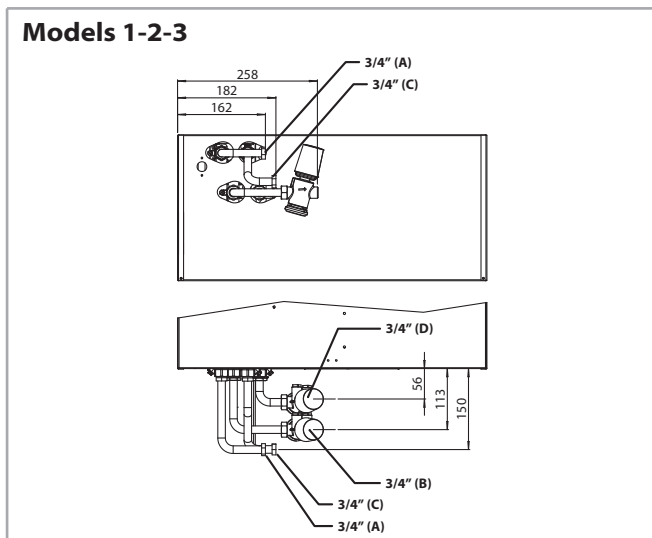

(A) = Water inlet (main coil) - Female connection

(B) = Water outlet (main coil) - Male connection

(C) = Water inlet (additional coil) - Female connection

(D) = Water outlet (additional coil) - Male connection

Main coil

Model	Valve fitted on the unit		Valve not fitted on the unit		DN	(∅)	Qwr
	ID	Code	ID	Code			
1-2-3	V20VSK6BPM 150-1050	9079771	V20VSK6BPS 150-1050	9079761	15	3/4"	150-1050

Additional coil

Model	Valve fitted on the unit		Valve not fitted on the unit		DN	(∅)	Qwr
	ID	Code	ID	Code			
1-2-3	V20VSK6BAM 150-1050	9079773	V20VSK6BAS 150-1050	9079763	15	3/4"	150-1050

Kit with DANFOSS valve

The flow rate can be calculated without any special tools. In order to modify the presetting (the factory value is 100%), go ahead as follow:

1. Remove the blue protective cover or the actuator fitted on the unit
2. Lift up the indicator (DN 25-32)
3. Turn (clockwise to decrease) on the new value
4. Set off the grey indicator again into the closed position (DN 25-32)

The presetting range shows flow rate values between 10-0 (DN 15-20). The clockwise rotation reduces the requested flow rate value whereas the counterclockwise rotation increases it.



DANFOSS technical characteristics

Nominal diameter	DN	15	15HF
Type	-	90-450	150-1050
Flow rate range	l/h	650	1200
Adjustment range	%	10-100	
Differential pressure	Dp min.	16	25
	Dp max.	600	
Nominal pressure	PN	25	

Operation limits of the DANFOSS balancing valves

- Maximum operating temperature: 120 °C
- Maximum % of water/glycol mixture: 50%
- Minimum operating temperature: -10 °C

Balancing valves for DANFOSS main coil

The valve is supplied equipped with 230 Volt electro-thermal actuator for the ON/OFF control.

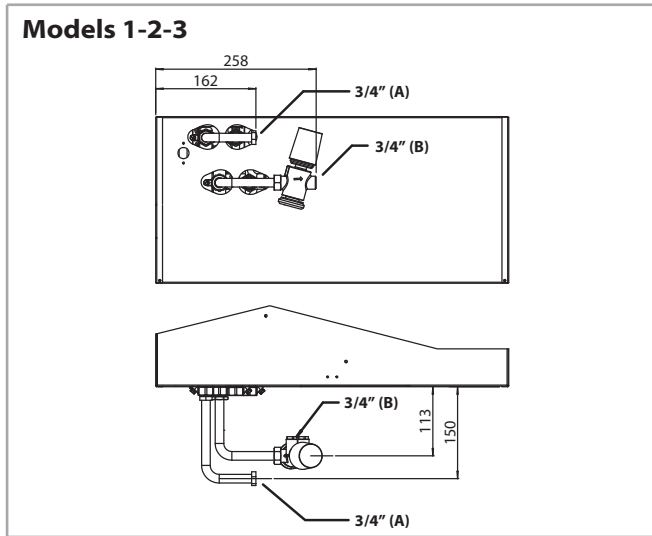

(A) = Water inlet - Female connection

(B) = Water outlet - Male connection

Model	Fitted		Not mounted		DN	(Ø)	Range (l/h)
	Code	ID	Code	ID			
1-2-3	9079774	V2DFSK6BPM150-1050	9079784	V2DFSK6BPS150-1050	15HF	3/4"	150-1050

Balancing valves for DANFOSS main and additional coil

2 way valve for main and additional coil and assembly kit.

The valve is supplied equipped with 230 Volt electro-thermal actuator for the ON/OFF control.

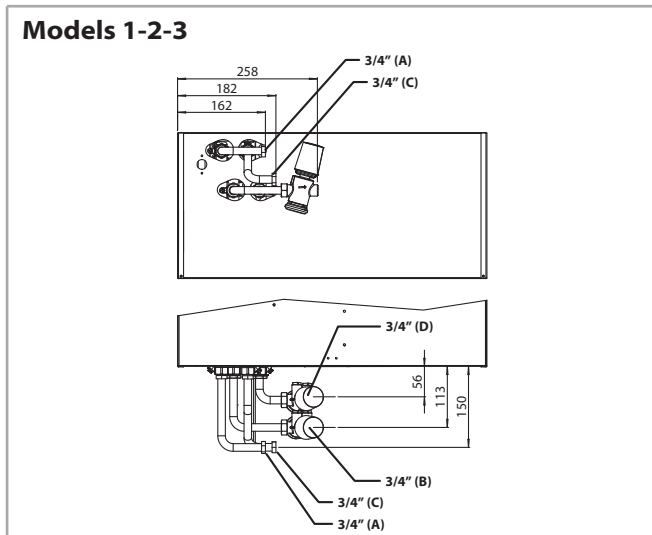

(A) = Water inlet (main coil) - Female connection

(B) = Water outlet (main coil) - Male connection

(C) = Water inlet (additional coil) - Female connection

(D) = Water outlet (additional coil) - Male connection

Main coil

Model	Fitted		Not mounted		DN	(Ø)	Range (l/h)
	Code	ID	Code	ID			
1-2-3	9079774	V2DFSK6BPM150-1050	9079784	V2DFSK6BPS150-1050	15HF	3/4"	150-1050

Additional coil

Model	Code	ID	Code	ID	DN	(Ø)	Range (l/h)



CISQ is a member of



The International Certification Network
www.iqnet-certification.com

CERTIFICATO N. **ICIM-9001-000545-10**
CERTIFICATE No. _____

SI CERTIFICA CHE IL SISTEMA DI GESTIONE PER LA QUALITÀ DI
WE HEREBY CERTIFY THAT THE QUALITY MANAGEMENT SYSTEM OPERATED BY

SABIANA S.P.A.

SEDE CENTRALE / HEADQUARTER

VIA PIAVE, 53 20011 CORBETTA MI IT - Italia

PER LE UNITÀ OPERATIVE VEDERE L'ALLEGATO
FOR OPERATIVE UNITS SEE ATTACHMENT

È CONFORME ALLA NORMA / IS IN COMPLIANCE WITH THE STANDARD

UNI EN ISO 9001:2015

Sistema di Gestione per la Qualità / Quality Management System

PER LE SEGUENTI ATTIVITÀ / FOR THE FOLLOWING ACTIVITIES

EA: 18

Progettazione, produzione e assistenza di apparecchiature per il riscaldamento e il condizionamento dell'aria (aerotermi, termostrisce radianti, ventilconvettori e unità trattamento aria). Progettazione e produzione di canne fumarie.

Design, production and service of heating and air conditioning equipment (unit heaters, radiant panels, fan coil units and air handling units). Design and production of chimneys.

Riferirsi alla documentazione del Sistema di Gestione per la Qualità aziendale per l'applicabilità dei requisiti della norma di riferimento.
Refer to the documentation of the Quality Management System for details of application to reference standard requirements.

Il presente certificato è soggetto al rispetto del documento ICIM "Regolamento per la certificazione dei sistemi di gestione" e al relativo Schema specifico.
The use and the validity of this certificate shall satisfy the requirements of the ICIM document "Rules for the certification of company management systems" and specific Scheme.

Per informazioni puntuali e aggiornate circa eventuali variazioni intervenute nello stato della certificazione di cui al presente certificato, si prega di contattare il n° telefonico +39 02 725341 o indirizzo e-mail info@icim.it.

For timely and updated information about any changes in the certification status referred to in this certificate, please contact the number +39 02 725341 or email address info@icim.it.

DATA EMISSIONE
FIRST ISSUE
10/06/1996

EMISSIONE CORRENTE
CURRENT ISSUE
10/04/2024

DATA DI SCADENZA
EXPIRING DATE
09/04/2027

Vincenzo Delacqua

Rappresentante Direzione / Management Representative

ICIM S.p.A.

Piazza Don Enrico Magelli, 75 - 20099 Sesto San Giovanni (MI)
www.icim.it



MS N° 0004



www.cisq.com

CISQ è la Federazione Italiana di Organismi di
Certificazione dei sistemi di gestione aziendale. CISQ
is the Italian Federation of management system
Certification Bodies.

Follow us on

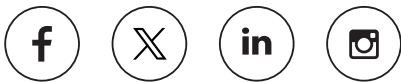

Sabiana app

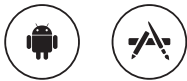

99A4790100HY 04/2025



SABIANA SpA

Società a socio unico

via Piave 53 - 20011 Corbetta (MI) Italy

T. +39 02 97203 1 r.a. - F. +39 02 9777282

info@sabiana.it

www.sabiana.it



Sabiana 2 and Sabiana 3 - Operative unit "via Virgilio 2 - Magenta (MI)"

Sabiana 4 - Operative unit "via Zanella 27 - Corbetta (MI)"