



# Elegant ECM

Ceiling Air Conditioner

TECHNICAL LEAFLET

# Elegant ECM

## Ceiling Air Conditioner



**Elegant ECM** air conditioners allow to heat and cool very economically small and medium areas, like shops, show rooms, workshops, supermarkets.

The range is made up of 12 models:

**RE-ECM** version, for heating only, is made up of **8 models**, and **PE-ECM** version, for heating and cooling, is made up of **4 models**.

All models are for ceiling installation and for hot/chilled water supply.

The **Elegant ECM** series uses an innovative brushless synchronous permanent magnet electric motor controlled by an inverter card that is directly installed on the unit.

The intake of the air is from the bottom side of the unit and the air supply is from the 4 lateral grids which have individually controllable louvres for the best distribution of the air.

The condensate drain is made through an electronically controlled micro-pump, supplied on every standard PE-ECM model.

Different remote controls of the air flow and of the room temperature are available and it is possible to control up to 8 units with only one remote control.

All the **Elegant ECM** units can be supplied with a wide range of controls using the **Modbus RTU - RS 485** communication protocol.



Beside the low installation and running cost, the **Elegant ECM Sabiana** air conditioners offer the following advantages:

- they take up a small amount of the valuable space in the room, there is not any ducting system and the walls are free.
- they are versatile and provide flexibility of installation: also where there is no false ceiling it is possible to distribute the air evenly.
- they provide easy control and are easily installed.



## Casing

Made of steel on both top and bottom sections and it is then finished with an epoxy-polyester powder coating dried at 180 °C, in white RAL 9016.

The lower casing is also the condensate collection tray.

The components are assembled with screws and so it is possible to quickly dismantle it for inspection when needed.

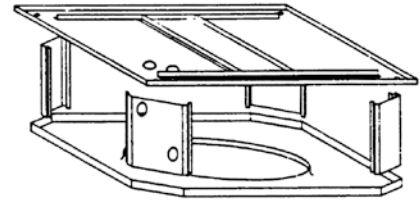

## Outlet grids

The discharge of the air is obtained through 4 grids on the 4 lateral sides. They are comprised by a frame in which the louvres are individually adjustable. It is very easy to take off these grids, allowing for easy maintenance of the coil and of the condensate tray.

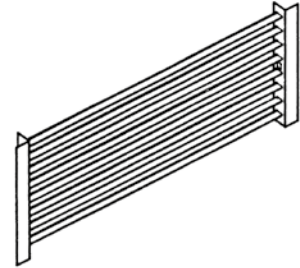

## Electronic motor

Three phase permanent magnet brushless electronic motor.

The inverter board that controls the motor operation is powered by 230 Volt, single-phase and it generates a frequency modulated wave form power supply. The electric power supply required for the machine is therefore single-phase with voltage of 230-240V and frequency of 50-60Hz.



## Helicoidal fan

The fan is made with statically and dynamically balanced plastic blades. Its rational high-capacity profile provides the maximum air volume with the minimum energy consumption. The fan hub is secured onto the motor shaft and it is protected by a safety guard.



## Coil

The coil is constructed of copper tubes with aluminium fins and steel headers.

The supply and return connections have a female threading, 1" diameter, and they allow the connection either vertically from above or horizontally from a side.

The coil is supplied in two versions: with 1 row and with 2 rows.

The coil is not suitable for use in corrosive atmosphere or in environments where aluminium may be subject to corrosion.

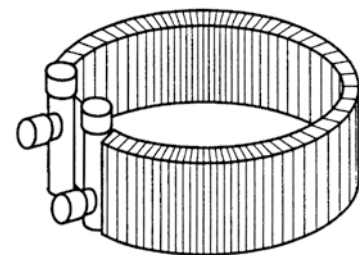

## Condensate micro-pump

The PE-ECM model for cooling is always supplied with an integral micropump (discharge head 3m, water flow 6l/h). The pump is installed in the condensate collected tray. This pump controls the level of the condensate collected in the tray and drain it when necessary.



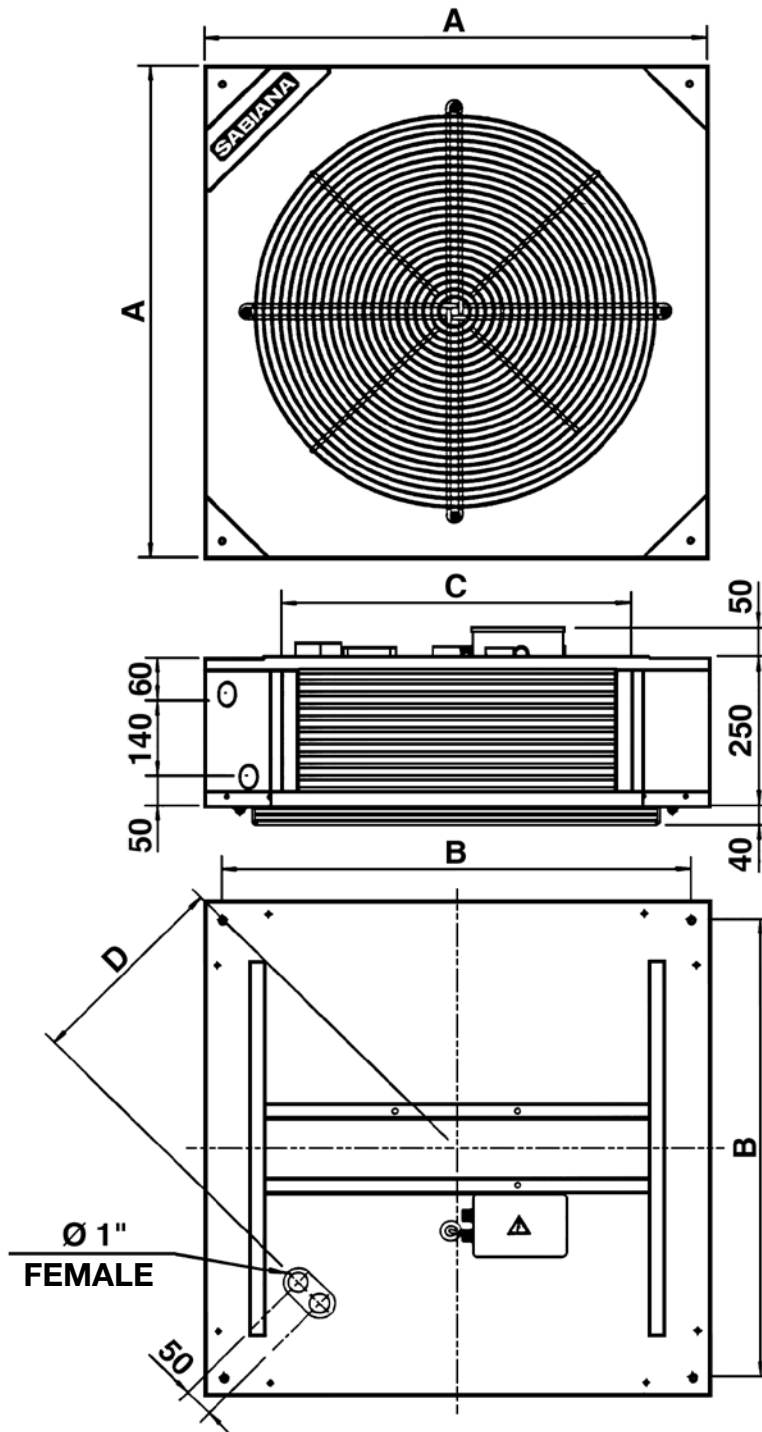

Elegant ECM

with 1 row coil (only heating)

Model	RE-ECM				
	11	21	31	41	
Dimensions (mm)	A	600	750	750	830
	B	540	690	690	770
	C	330	480	480	560
	D	220	287	300	344
Weight (kg)	26	31	32	38	
Water content (Liters)	0,8	1,1	1,1	1,3	

with 2 row coil (heating and cooling)

Model	RE-ECM / PE-ECM				
	12	22	32	42	
Dimensions (mm)	A	600	750	750	830
	B	540	690	690	770
	C	330	480	480	560
	D	220	287	300	344
Weight (kg)	28	34	35	40	
Water content (Liters)	1,8	2,4	2,4	2,7	

## RE-ECM units (heating only)

The following standard rating conditions are used:

### HEATING (winter mode)

Entering air temperature: +20°C

Water temperature: +70/60°C

Model		RE-ECM 11						RE-ECM 12					
Inverter Power (V)		5	6	7	8	9	10	5	6	7	8	9	10
Air flow	m <sup>3</sup> /h	1045	1265	1465	1635	1805	1890	1005	1215	1410	1570	1735	1820
Heating	kW	5,88	6,60	7,20	7,67	8,14	8,36	9,56	10,88	12,01	12,88	13,74	14,15
Dp Heating	kPa	11,2	13,8	16,2	18,1	20,2	21,1	6,90	8,80	10,5	11,9	13,3	14,1
Sound power Lw	dB(A)	44	48	52	54	56	57	44	48	52	54	56	57
Sound pressure Lp (*)	dB(A)	35	39	43	45	47	48	35	39	43	45	47	48
Sound pressure Lp (**)	dB(A)	31	35	39	41	43	44	31	35	39	41	43	44
Fan	W	16	24	37	51	69	81	16	24	37	51	69	81

Model		RE-ECM 21						RE-ECM 22					
Inverter Power (V)		5	6	7	8	9	10	5	6	7	8	9	10
Air flow	m <sup>3</sup> /h	1380	1645	1925	2175	2415	2600	1325	1580	1850	2090	2320	2500
Heating	kW	7,59	8,46	9,32	10,03	10,68	11,18	12,64	14,26	15,81	17,13	18,31	19,20
Dp Heating	kPa	7,9	9,6	11,4	13,0	14,6	15,9	13,0	16,2	19,5	22,5	25,4	27,7
Sound power Lw	dB(A)	48	51	54	57	60	62	48	51	54	57	60	62
Sound pressure Lp (*)	dB(A)	39	42	45	48	51	53	39	42	45	48	51	53
Sound pressure Lp (**)	dB(A)	35	38	41	44	47	49	35	38	41	44	47	49
Fan	W	23	36	55	75	104	136	23	36	55	75	104	136

Model		RE-ECM 31						RE-ECM 32					
Inverter Power (V)		5	6	7	8	9	10	5	6	7	8	9	10
Air flow	m <sup>3</sup> /h	1880	2245	2560	2890	3140	3180	1810	2160	2460	2780	3020	3060
Heating	kW	8,70	9,71	10,50	11,29	11,85	11,95	14,97	16,80	18,24	19,68	20,71	20,89
Dp Heating	kPa	10,5	12,7	14,7	16,7	18,2	18,5	14,2	17,5	20,2	23,2	25,4	25,8
Sound power Lw	dB(A)	50	53	56	59	61	61	50	53	56	59	61	61
Sound pressure Lp (*)	dB(A)	41	44	47	50	52	52	41	44	47	50	52	52
Sound pressure Lp (**)	dB(A)	37	40	43	46	48	48	37	40	43	46	48	48
Fan	W	37	59	86	121	162	164	37	59	86	121	162	164

Model		RE-ECM 41						RE-ECM 42					
Inverter Power (V)		5	6	7	8	9	10	5	6	7	8	9	10
Air flow	m <sup>3</sup> /h	2475	3090	3515	3995	4450	4680	2380	2970	3380	3840	4280	4500
Heating	kW	10,40	11,84	12,75	13,72	14,57	14,99	17,49	20,08	21,71	23,44	25,00	25,73
Dp Heating	kPa	6,4	8,1	9,2	10,5	11,7	12,4	4,8	6,2	7,1	8,2	9,2	9,7
Sound power Lw	dB(A)	47	51	54	57	59	60	47	51	54	57	59	60
Sound pressure Lp (*)	dB(A)	38	42	45	48	50	51	38	42	45	48	50	51
Sound pressure Lp (**)	dB(A)	34	38	41	44	46	47	34	38	41	44	46	47
Fan	W	32	54	77	108	150	174	32	54	77	108	150	174

(\*) = Measurement performed at 3 meter from the source, room volume of 500m<sup>3</sup>, reverberation period of 2 s, directional factor Q=2 (hemisphere sound emission).

(\*\*) = Measurement performed at 3 meter from the source, room volume of 1500m<sup>3</sup>, reverberation period of 2 s, directional factor Q=2 (hemisphere sound emission).

## PE-ECM units (heating and cooling)

The following standard rating conditions are used:

### COOLING (summer mode)

Entering air temperature: +27°C bulbo secco 50% U.R.

Water temperature: +7°C entrata +12°C uscita

### HEATING (winter mode)

Entering air temperature: +20°C

Water temperature: +70/60°C

Model		PE-ECM 12						PE-ECM 22					
Inverter Power (V)		5	6	7	8	9	10	5	6	7	8	9	10
Air flow	m <sup>3</sup> /h	1005	1215	1410	1570	1735	1820	1325	1580	1850	2090	2320	2500
Cooling total emission	kW	3,89	4,30	4,65	4,80	5,17	5,20	5,31	5,83	6,33	6,74	7,13	7,38
Cooling sensible emission	kW	3,14	3,58	3,98	4,23	4,61	4,71	4,14	4,68	5,22	5,68	6,12	6,44
Heating	kW	9,56	10,88	12,01	12,88	13,74	14,15	12,64	14,26	15,81	17,13	18,31	19,20
Dp Raffreddamento	kPa	6,3	7,6	8,8	9,3	10,6	10,7	12,7	15,0	17,4	19,4	21,5	22,9
Dp Heating	kPa	6,9	8,8	10,5	11,9	13,3	14,1	13,0	16,2	19,5	22,5	25,4	27,7
Sound power Lw	dB(A)	44	48	52	54	56	57	48	51	54	57	60	62
Sound pressure Lp (*)	dB(A)	35	39	43	45	47	48	39	42	45	48	51	53
Sound pressure Lp (**)	dB(A)	31	35	39	41	43	44	35	38	41	44	47	49
Fan	W	16	24	37	51	69	81	23	36	55	75	104	136

Model		PE-ECM 32						PE-ECM 42					
Inverter Power (V)		5	6	7	8	9	10	5	6	7	8	9	10
Air flow	m <sup>3</sup> /h	1810	2160	2460	2780	3020	3060	2380	2970	3380	3840	4280	4500
Cooling total emission	kW	6,43	7,01	7,51	7,99	8,41	8,52	7,19	8,09	8,84	9,32	9,83	10,07
Cooling sensible emission	kW	5,21	5,87	6,44	7,02	7,50	7,60	6,40	7,53	8,40	9,15	9,83	10,07
Heating	kW	14,97	16,80	18,24	19,68	20,71	20,89	17,49	20,08	21,71	23,44	25,00	25,73
Dp Raffreddamento	kPa	16,3	19,0	21,5	24,1	26,4	27,0	7,6	9,4	11,0	12,1	13,4	14,0
Dp Heating	kPa	14,2	17,5	20,2	23,2	25,4	25,8	4,8	6,2	7,1	8,2	9,2	9,7
Sound power Lw	dB(A)	50	53	56	59	61	61	47	51	54	57	59	60
Sound pressure Lp (*)	dB(A)	41	44	47	50	52	52	38	42	45	48	50	51
Sound pressure Lp (**)	dB(A)	37	40	43	46	48	48	34	38	41	44	46	47
Fan	W	37	59	86	121	162	164	32	54	77	108	150	174

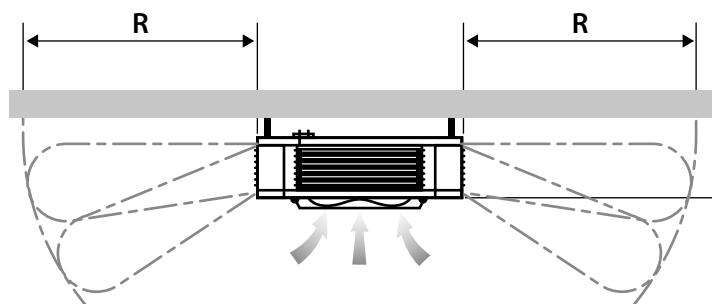

Model	High speed		Low speed	
	Maximum height (m)	Surface (m)	Maximum height (m)	Surface (m)
	H	R	H	R
1	3,5	3,5	3,0	2,5
2	3,5	3,8	3,0	2,6
3	4,0	4,0	3,5	3,0
4	4,5	4,5	4,0	3,5

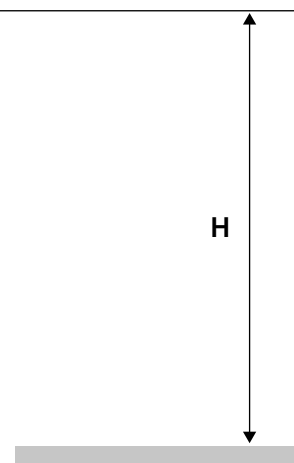

## 3-way valve kit

Composed by:

- one 3-way valve 3/4" Kvs 4,7
- one actuator
- pipe connections

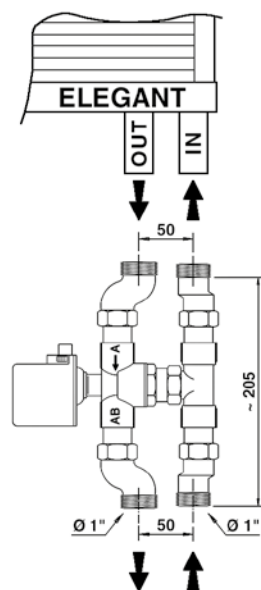

## Hanging brackets

Composed by 4 eye bolts and screws.

- 1 Washer for screw M8
- 2 Screw M8 x 16
- 3 Eye bolt female M8

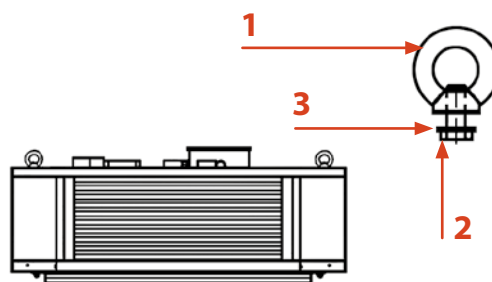

## Cover panel

To be mounted on the fan guard.

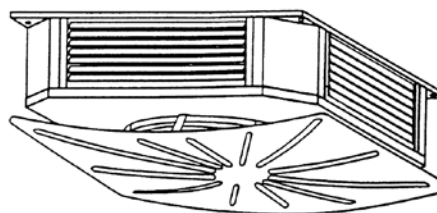

## Electronic wall controls

For each unit must be provided the ADC converter or the UPE-AU power unit for wall controls

<b>WM-3V</b>	3 speed control (to be used with ADC-M or ADC-S only)
<b>WM-T</b>	3 speed control with electronic thermostat and summer/winter switch (to be used with ADC-M or ADC-S only)
<b>WM-TQR</b>	3 speed control with electronic thermostat and centralized/manual summer/winter switch (to be used with ADC-M or ADC-S only)
<b>WM-AU</b>	Automatic speed control with electronic thermostat and summer/winter switch (to be used with UPEM-AU or UPE-AU only)
<b>T-MB</b>	Wall control (to be used with UPEM-AU or UPE-AU only)
<b>T2T</b>	Electromechanical thermostat with summer/winter switch (only for 2 pipe units) (to be used with ADC-M or ADC-S only)
<b>ADC-M</b>	ADC signal converter for wall controls fitted on the unit, for WM-3V, WM-T, WM-TQR and T2T controls
<b>ADC-S</b>	ADC signal converter for wall controls supplied with separate packaging, for WM-3V, WM-T, WM-TQR and T2T controls
<b>UPEM-AU</b>	UPE-AU power unit for WM-AU and T-MB remote controls, fitted on the unit
<b>UPE-AU</b>	UPE-AU power unit for WM-AU and T-MB remote controls, not fitted on the unit

## Electronic controls for MBE boards

<b>MBE-M</b>	MBE electronic board fitted on the unit
<b>MBE-S</b>	MBE electronic board supplied with separate packaging
<b>T-MB</b>	T-MB wall control (to be used with MBE board only)
<b>PSM-DI</b>	PSM-DI multifunction control panel (to be used with MBE board only)
<b>T-DI</b>	T-DI touch screen multifunction control panel (to be used with MBE board only)
<b>SabWeb</b>	Web gateway for Sabiana Cloud (to be used with MBE board only)

## Sabianet management system for a network of Elegant ECM

<b>Sabianet</b>	Hardware/software supervisory system (to be used with MBE board only)
<b>Router-S</b>	Router for Sabianet (default) or for BMS systems not provided by Sabiana
<b>SIOS</b>	Relay output board for Sabianet



A company of Arbonia Group  
**ARBONIA** ▲

Follow us



Sabiana app



---

**SABIANA SpA**

Società a socio unico

Via Piave 53 - 20011 Corbetta (MI) Italia

T. +39 02 97203 1 r.a. • F. +39 02 9777282

info@sabiana.it

**www.sabiana.it**